

TAURUS®

Assembly and Operating Instructions

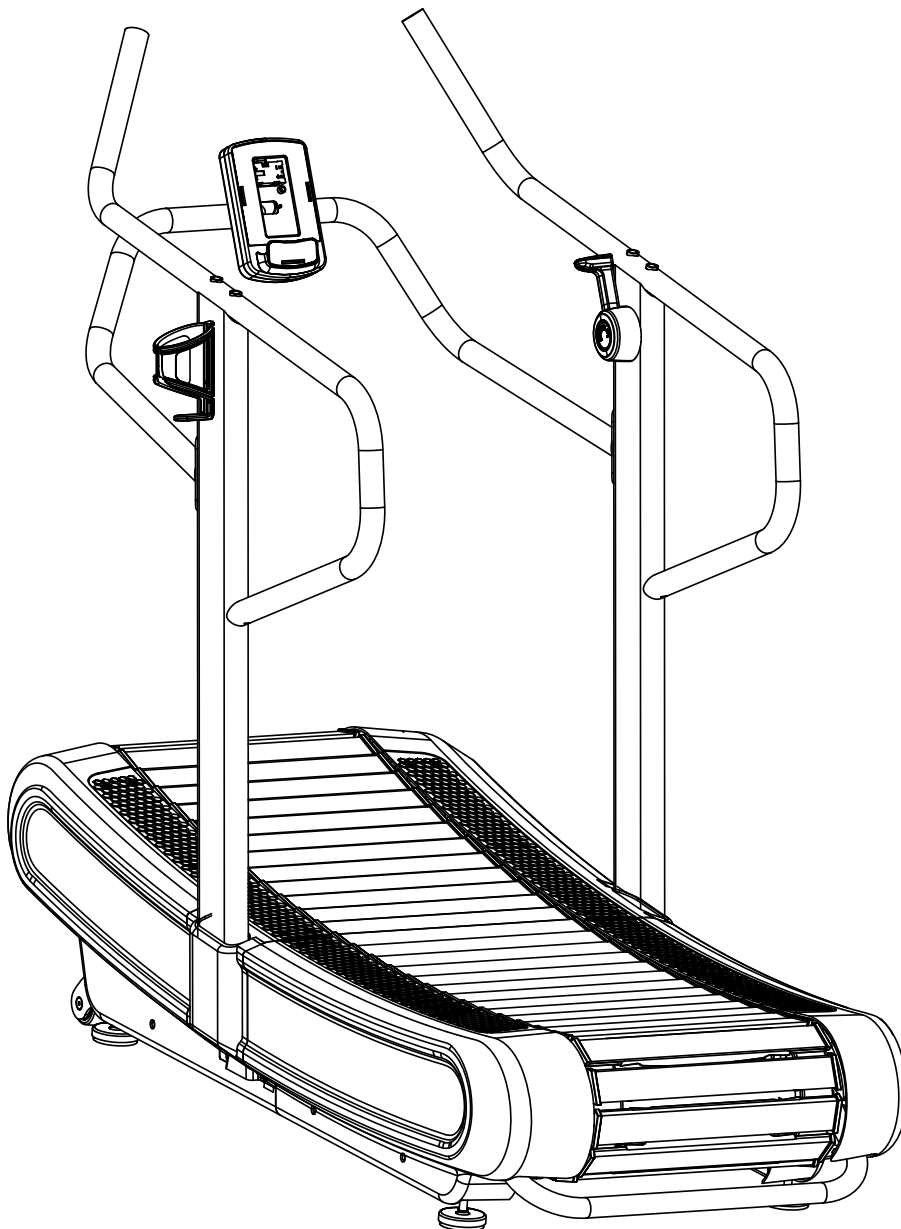

max. 150 kg



~ 30 - 60 Min.



128 kg

L 172 | W 81 | H 157

FSUKCVTM2554.02.01

SKU: CVTM2554

TAURUS ELITE RUN

Content

1	GENERAL INFORMATION	8
1.1	Technical Data	8
1.2	Personal Safety	9
1.3	Electrical Safety	10
1.4	Set-Up Place	11
2	ASSEMBLY	12
2.1	General Instructions	12
2.2	Scope of Delivery	13
2.3	Assembly	15
3	OPERATING INSTRUCTIONS	19
3.1	Console Display	19
3.2	Button Functions	20
3.3	Battery Compartment	21
3.4	First Steps	21
3.5	Pause programme - Pause mode	22
3.6	End programme - stop mode	22
3.7	Programmes	23
3.7.1	Quick Start	23
3.7.2	Interval 10/20 and Interval 20/10	23
3.7.3	Interval Custom	24
3.7.4	Target Time, Target Distance and Target Calories	24
3.7.5	Target HR	25
4	STORAGE AND TRANSPORT	26
4.1	General Instructions	26
4.2	Transportation Wheels	26
5	TROUBLESHOOTING, CARE AND MAINTENANCE	27
5.1	General Instructions	27
5.2	Faults and Fault Diagnosis	27
5.3	Maintenance and Inspection Calendar	28
6	DISPOSAL	28

7	RECOMMENDED ACCESSORIES	29
8	ORDERING SPARE PARTS	30
7.1	Serial Number and Model Name	30
8.1	Parts List	31
8.2	Exploded Drawing	33
9	WARRANTY	34
10	CONTACT	36

Dear customer,

Thank you for choosing a high-quality equipment of the brand Taurus®. Taurus® offers sports and fitness equipment for the sophisticated home sport and the equipment of fitness studios and business customers. With Taurus® fitness equipment, the focus is on what sport is all about: maximum performance! Therefore, the equipment is developed in close consultation with athletes and sports scientists. Because athletes know best what makes perfect fitness equipment.

Further information can be found at www.fitshop.co.uk

Intended Use

The equipment may only be used for its intended purpose.

This fitness equipment is suitable for home use, semi-professional use and commercial or professional use. The semi-professional sector includes, for example, institutional facilities such as hospitals, schools, hotels and associations. Professional use refers to commercial use, e.g. in a fitness studio.

Legal Notice

Fitshop GmbH
Europe's No. 1 for home fitness

International Headquarters
Flensburger Straße 55
24837 Schleswig
Germany

Management:
Christian Grau
Sebastian Campmann
Dr. Bernhard Schenkel
No. HRB 1000 SL
Local Court Flensburg
European VAT Number: DE813211547

Disclaimer

© TAURUS is a registered brand of the company Fitshop GmbH. All rights reserved. Any use of this trademark without the explicit written permission of Fitshop is prohibited.

Product and manual are subject to change. Technical data can be changed without advance notice.

FITSHOP

Europe's No.1 for Home Fitness

ABOUT THIS MANUAL

Please carefully read the entire manual before installation and first use. The manual will help you to quickly set up the system and explains how to safely use it. Make sure that all persons exercising with the equipment (especially children and persons with physical, sensory, mental or motor disabilities) are informed about this manual and its contents in advance. In case of doubt, responsible persons must supervise the use of the equipment.



Due to ongoing changes and software optimisations, the manual may have to be updated. If you notice any discrepancies during assembly or use, please refer to the manual uploaded to the webshop. The latest manual is always available there.

This equipment has been manufactured according to the latest safety knowledge. As far as possible, potential safety hazards which could cause injury have been eliminated. Make sure to carefully follow the instructions and that all parts are securely in place. If required, read through the instructions again to correct any mistakes.

Training devices must be classified according to accuracy and use. Accuracy classes are only applicable to devices that display training data.

Accuracy classes

Class A: high accuracy.

Class B: medium accuracy.

Class C: low accuracy.

The use classes explain the intended use of the training device.

Use classes

Class S (studio): professional and/or commercial use.

These training devices are intended for the use in training rooms of facilities such as sports clubs, school facilities, hotels, clubs and studios whose access and supervision is specifically regulated by the owner (person with legal responsibility).

Class H (home use): use at home.

These stationary training devices are intended for the use in private homes where access to the training device is regulated by the owner (person with legal responsibility).

Please pay close attention to the safety and maintenance instructions given here. The contract partner cannot be held liable for damage to health, accidents or damage to the equipment when it is not used in accordance with these instructions.

The following safety instructions may appear in this manual:

► **ATTENTION**

This notice indicates potentially hazardous situations which, if not avoided, may result in property damage.

⚠ **CAUTION**

This notice indicates potentially hazardous situations which, if not avoided, may result in slight or minor injuries!

⚠ **WARNING**

This notice indicates potentially hazardous situations which, if not avoided, may result in death or serious injuries!

⚠ **DANGER**

This notice indicates potentially hazardous situations which, if not avoided, will result in death or serious injuries!

ⓘ **NOTICE**

This notice indicates further useful information.

Retain these instructions in a safe place for future reference, maintenance or when ordering replacement parts.

1.1 Technical Data

LCD - display of:

- + Time
- + Speed
- + Distance
- + Calories
- + Heart rate (when using a chest strap)
- + Watt
- + Pace

Training programmes overall:	7
Quick Start:	1
Interval programmes:	3 (1 customized)
Target programmes:	3
Heart rate controlled programmes:	1

Weight and dimensions:

Article weight (gross, incl. packaging):	149 kg
Article weight (net, excl. packaging):	128 kg
Package dimensions (LxWxH) approx.:	189 cm x 88 cm x 45.5 cm
Set-up dimensions (LxWxH) approx.:	172 cm x 81 cm x 157 cm
Maximum user weight:	150 kg
Use class:	S

1.2 Personal Safety

DANGER

- + Before you start using the equipment, you should consult your physician that this type of exercise is suitable for you from a health perspective. Particularly affected are persons who: have a hereditary disposition to high blood pressure or heart disease, are over the age of 45, smoke, have high cholesterol values, are overweight and/or have not exercised regularly in the past year. If you are under medical treatment that affects your heart rate, medical advice is absolutely essential.
- + Note that excessive training can seriously endanger your health. Please also note that heart rate monitoring systems can be inaccurate. If you notice any signs of weakness, nausea, dizziness, pain, shortness of breath, or other abnormal symptoms, stop exercising immediately and seek advice from your doctor if necessary.
- + The owner must communicate all warnings and instructions to the user.

WARNING

- + This equipment may not be used by children under the age of 14.
- + Children should not be allowed unsupervised access to the equipment.
- + Persons with disabilities must have a medical license and must be under strict observation when using the equipment.
- + The equipment is strictly for use by one person at a time.
- + If your equipment provides a safety key, the clip of the safety key must be attached to your clothing before starting your training. In the event of a fall, the EMERGENCY STOP of the equipment can be initiated.
- + If an emergency occurs and training has to be stopped abruptly, pull out the safety key, grab both handles, jump onto the side rails and wait until the treadmill has come to a complete stop.
- + Keep your hands, feet and other body parts, hair, clothing, jewellery and other objects well clear of moving parts.
- + During use, wear suitable sports clothing rather than loose or baggy clothing. When wearing sports shoes, make sure they have suitable soles, preferably made of rubber or other non-slip materials. Shoes with heels, leather soles, studs or spikes are unsuitable. Never exercise barefoot.

CAUTION

- + If your equipment needs to be connected to the power supply with a mains cable, make sure that the cable is not a potential tripping hazard.
- + Make sure that nobody is within the range of motion of the equipment during training so as not to endanger you or other persons.
- + Be aware that if adjustment devices are left protruding, they may impede the user's movement.

► **ATTENTION**

- + Do not insert any objects of any kind into the openings of the device.
- + To protect the equipment from use by unauthorised third parties, always remove the power cable (if existing) when not in use and store it in a safe place that is inaccessible to unauthorised persons (e.g. children).

1.3 Electrical Safety

 **DANGER**

- + In order to reduce the risk of an electric shock, always unplug the equipment from the mains socket immediately after your workout, before assembly or dismantling, and before maintenance or cleaning. Do not pull on the cable.

 **WARNING**

- + Do not leave the equipment unattended while the mains cable is plugged into the mains socket. During your absence, the mains cable must be removed from the mains socket to prevent improper use by third parties or children.
- + If the mains cable or plug is damaged or defective, contact your contract partner. Until repair, the equipment must not be used.

► **ATTENTION**

- + The equipment requires a mains connection of 220-230 V with 50 Hz mains voltage.
- + The equipment may only be connected directly to an earthed socket using the supplied mains cable. Extension cables must conform to VDE guidelines. Always completely unwind the mains cable.
- + The socket must be protected by a fuse with a minimum fuse rating of "16 A, slow blow".
- + Do not make any changes to the mains cable or the mains plug.
- + Keep the mains cable away from water, heat, oil and sharp edges. Do not route the mains cable underneath the equipment or under a carpet or rug, and do not place any objects on top of it.
- + If your purchased item is equipped with a TFT console, software updates must be carried out regularly. Follow the instructions on the console to perform the update(s).
- + The software systems on gym equipment with TFT consoles are set up only for the pre-installed apps. Do not install any additional apps.

 **NOTICE**

- + The pre-installed apps on TFT consoles are produced and provided by external manufacturers. Fitshop does not take any responsibility for the availability, functionality or contents of these apps.

1.4 Set-Up Place

⚠ WARNING

- + Do not place the equipment in main corridors or escape routes.

⚠ CAUTION

- + Make sure that there is a safety area behind the treadmill with a length of at least 2 m and a width at least equal to the width of the treadmill.
- + The training room should be well ventilated during training and not be exposed to any draughts.
- + Choose the place in which to set up the equipment such that there is enough free space/clearance to the front, the rear and to the sides of the equipment.
- + The free area in the direction from which the exercise equipment is accessed must be at least 0.6 m larger than the exercise area.
- + The set-up and mounting surface of the equipment should be flat, loadable and solid.

▶ ATTENTION

- + The device may only be used in one building, in sufficiently tempered and dry rooms (ambient temperatures between 10°C and 35°C). The equipment should not be used outdoors or in rooms with high humidity (over 70%) like swimming pools.
- + A floor protective mat/equipment underlay can help to protect high-quality floor coverings (parquet, laminate, cork, carpets) from dents and sweat and can help to level out slight unevenness.
- + For Class S equipment, the exercise equipment may only be used in areas where access, supervision and control are specifically regulated by the owner.

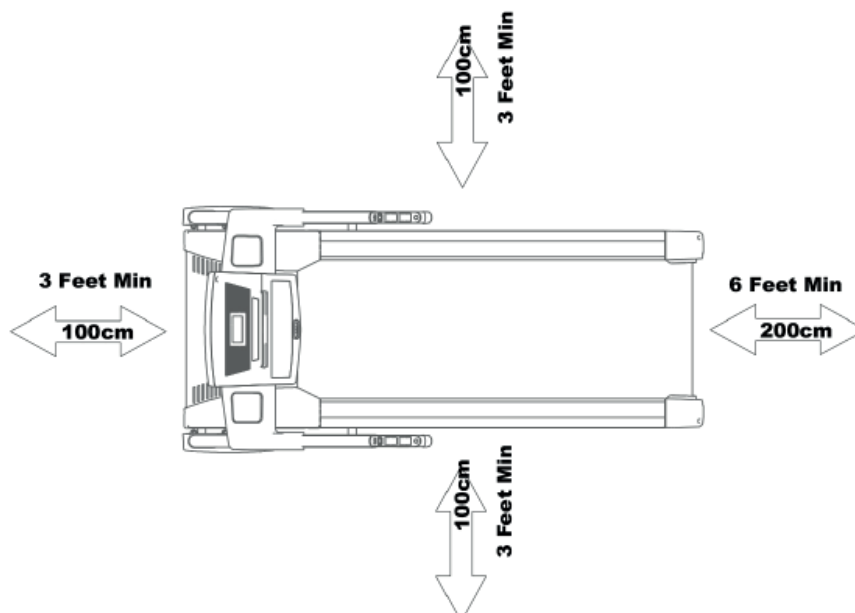

2.1 General Instructions



DANGER

- + Do not leave any tools, packaging materials such as foils or small parts lying around, as otherwise there is a danger of suffocation for children. Keep children away from the equipment during assembly.



WARNING

- + Pay attention to the instructions attached to the equipment in order to reduce the risk of injuries.



CAUTION

- + Do not open the packaging when it is lying on its side.
- + Ensure to have sufficient room for movement in each direction during assembly.
- + The assembly of the equipment must be carried out by at least two adults. If in doubt, seek the help of a third technically skilled person.



ATTENTION

- + To prevent damage to the equipment and the floor, assemble the equipment on a mat or packaging board.



NOTICE

- + In order to make the assembly as simple as possible, some screws and nuts to be used can already be pre-assembled.
- + Ideally, assemble the equipment at its later set-up place.

2.2 Scope of Delivery

The scope of delivery consist of the following parts. At the beginning, check whether all parts and tools belonging to the device are included in the scope of delivery and whether damage has occurred. In the event of complaints, the contractual partner must be contacted directly.

⚠ CAUTION

If parts of the scope of delivery are missing or damaged, the assembly must not be carried out.



Main body

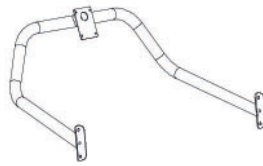

Console frame

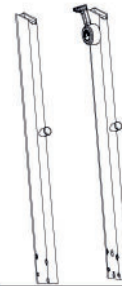

Upright post

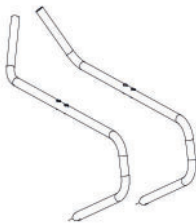

Hand rail left + right

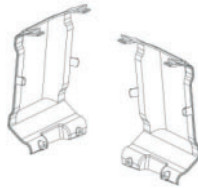

Upright post cover

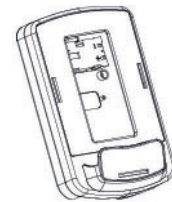

Console

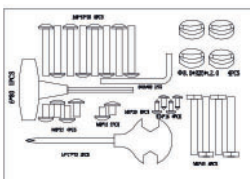

Bolt kit



Bottle holder

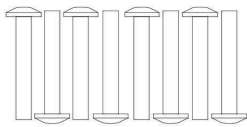

Allen head C.K.S half
thread bolt M8×55×20

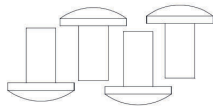

Allen head C.K.S full
thread bolt M8*25

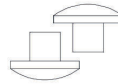

Allen head C.K.S full
thread bolt M8*15



Phillip head C.K.S
self-tapping screw ST4×16

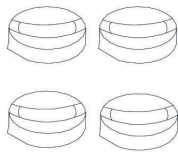

Curve washer
Φ8.5×R25×t2.0

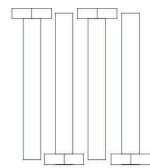

Hexagon socket
head full thread bolt

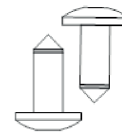

Philips Pan head full
thread screw M4*16

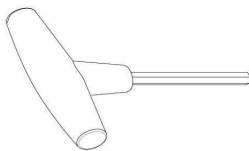

T shape wrench
6*80

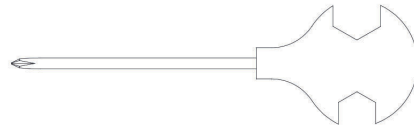

Cross open wrench
14*17*75



L shape wrench 6*35*80

2.3 Assembly

Before assembly, take a close look at the individual assembly steps shown and carry out the assembly in the order given.

NOTICE

- + First loosely screw all parts together and check that they fit properly. Tighten the screws using the tool only when you are instructed to do so.
- + If you have difficulty recognising the graphics, we recommend that you open and/or download the PDF instructions stored in the webshop on your end device (e.g. smartphone, tablet or PC). There you have the option of zooming in closer. Please note that the Adobe Acrobat Reader programme must be installed on your end device in order to open the file.

Step 1: Mounting the console

1. Connect the cable of the console (55) with the corresponding counterpart of the console frame (4).

ATTENTION

Be careful not to pinch the cables in the following step.

2. Fasten the console (55) to the console frame (4) with four M5*10 screws (83).

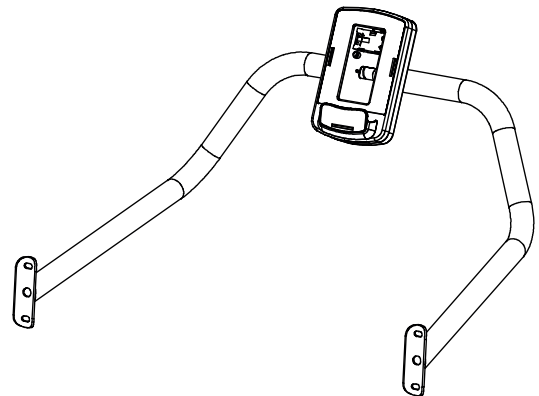
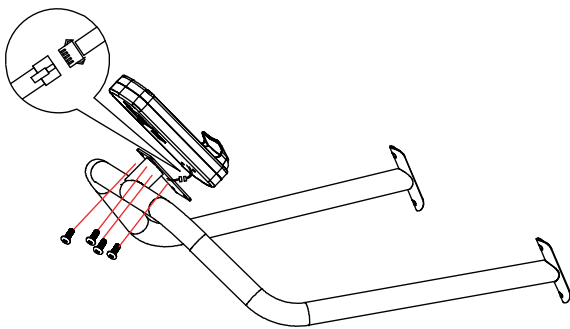

Step 2: Mounting the Console Masts

1. Connect the cables of the right upright post (2) with the cables of the main frame (1).

ATTENTION

Be careful not to pinch the cables in the following step.

2. Fix the two upright posts (2 & 3) to the main frame (1) with four M8*55*20 bolts (78) each.

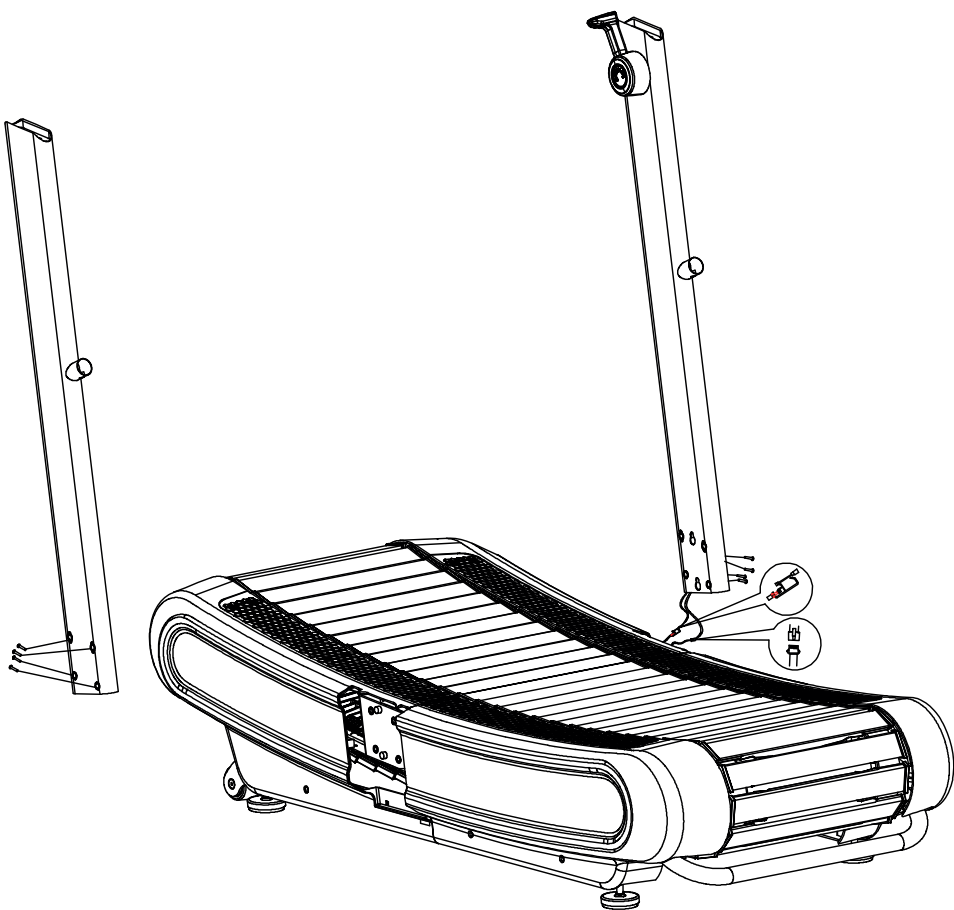
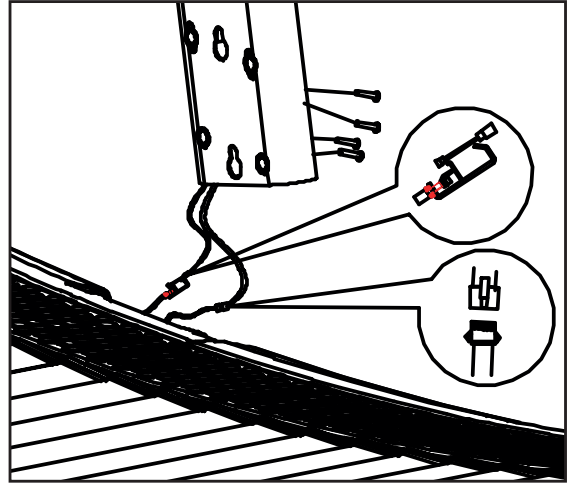

Step 3: Assembly of the handrails

Attach one handrail (6 & 105) to each of the two upright posts (2 & 3) with two M8*45 bolts (101) and one M8*15 bolt (66) each.

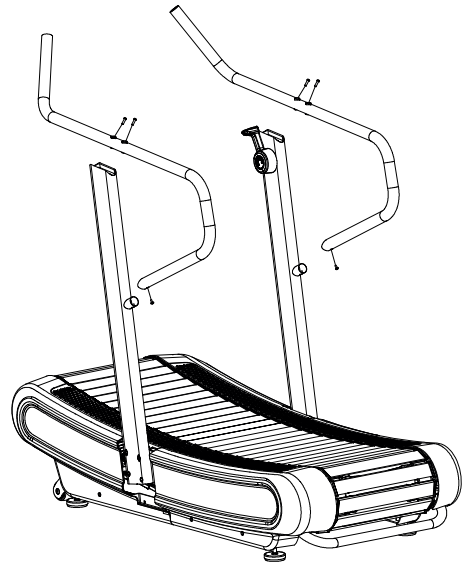

Step 4: Mounting the Console Unit

1. Connect the two cables of the right upright post (2) to their corresponding counterparts of the console frame.

► **ATTENTION**

Be careful not to pinch the cables in the following step.

2. Fix the console frame (4) to the two upright posts (2 & 3) with two M8*25 bolts (79) and two Ø8.5xR25xt2.0 curve washers each.

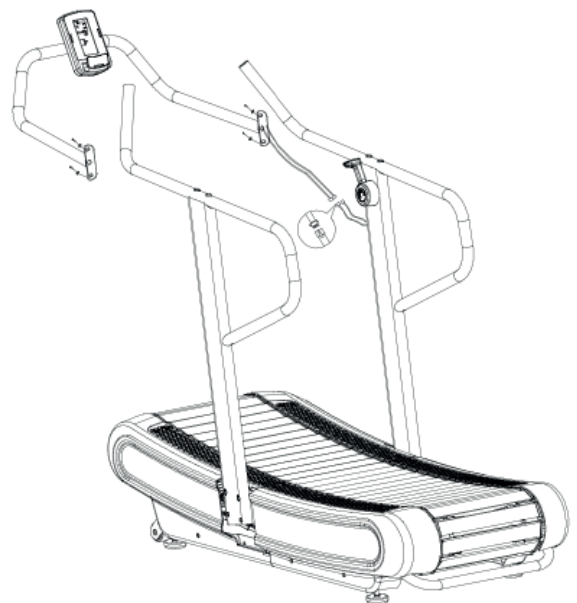

Step 5: Mounting the Covers

1. Fasten the covers (7 & 8) to the main frame (1) with two ST4*16 screws (97) each.
2. Finally, tighten all screws.

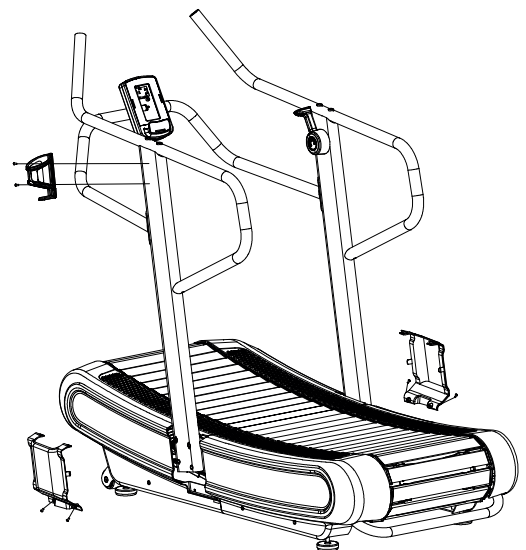

Step 6: Assembly of the bottle holder

Attach the bottle holder (110) to the left upright post (2) with two M4*16 screws (111).

Step 7: Alignment of the feet

If the floor is uneven, you can stabilize the treadmill by turning the setting screws under the main frame.

1. Lift the treadmill on the desired side and rotate the setting screws under the main frame.
2. Rotate the screws clockwise in order to remove them and to raise the running surface.
3. Rotate them counterclockwise in order to lower the running surface.

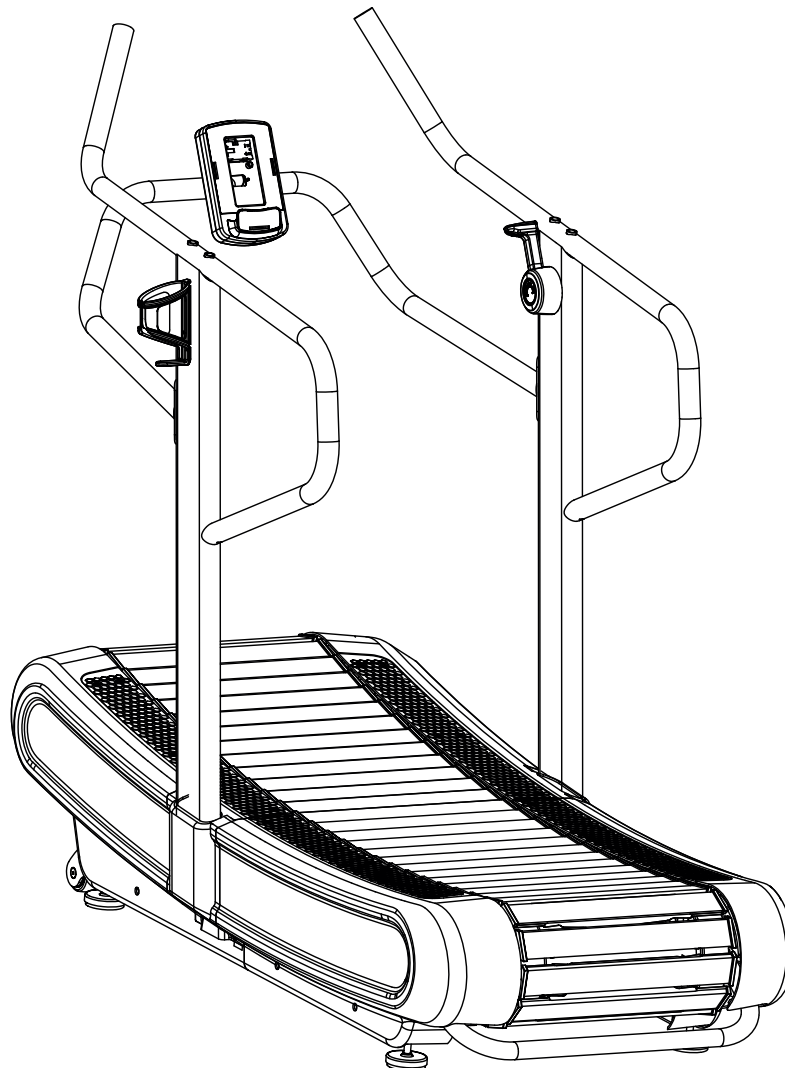

3 OPERATING INSTRUCTIONS

① NOTICE

- + Familiarise yourself with all the functions and setting options of the device before starting training. Have the proper use of this product explained to you by a specialist.
- + Bitte bedenken Sie, dass die Geräuschemission unter Belastung höher ist als ohne Last.

3.1 Console Display

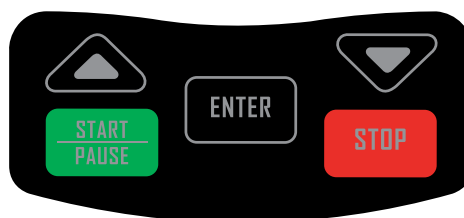
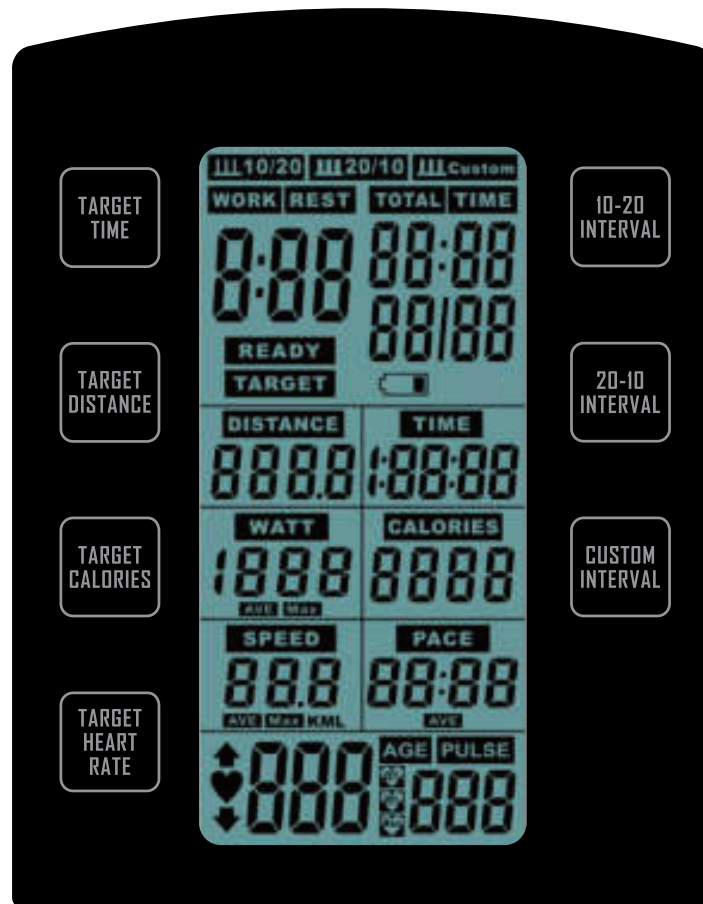

Display	Description
TIME	+ Display of the training time + Display range: 00:00-1:59:00 + Setting range: 1:00-1:59:00
DISTANCE	+ Display of the training distance + Display range: 0.5-100 + Setting range: 0,5-100
CALROIES	+ Display of calories burned + Display range: 0-2000 + Setting range: 1-2000
PULSE	+ Heart rate display (when using a chest strap) + Display range: 30-230 + Setting range: 30-230
WATT	+ Display of watt
SPEED	+ Display of speed
PACE	+ Display of pace
LOAD	+ Display of the resistance level within the watt display

3.2 Button Functions

Button	Description
START/PAUSE	+ Start or pause the training + Continue the training
STOP	+ Stop the training + 2 Sek. gedrückt halten, um Konsole neuzustarten
DOWN	+ Decrease values
UP	+ Increase values
10/20 INTERVAL	+ Quick-keys for the interval programmes: + 10/20 + 20/10 + Custom
20/10 INTERVAL	
CUSTOM INTERVAL	
TARGET TIME	+ Quick-keys for the target programmes: + Time + Distance + Calories + Heart Rate
TARGET DISTANCE	
TARGET CALORIES	
TARGET HEART RATE	
ENTER	+ Confirm the settings + Confirm the selection

3.3 Battery Compartment

The console is powered by two AA 1.5V batteries. In case the console is not working properly, the batteries might be running low. Follow the instructions to exchange the batteries.

1. Open the battery compartment cover and remove the batteries.
2. Insert two new AA 1.5V batteries and close the cover again.

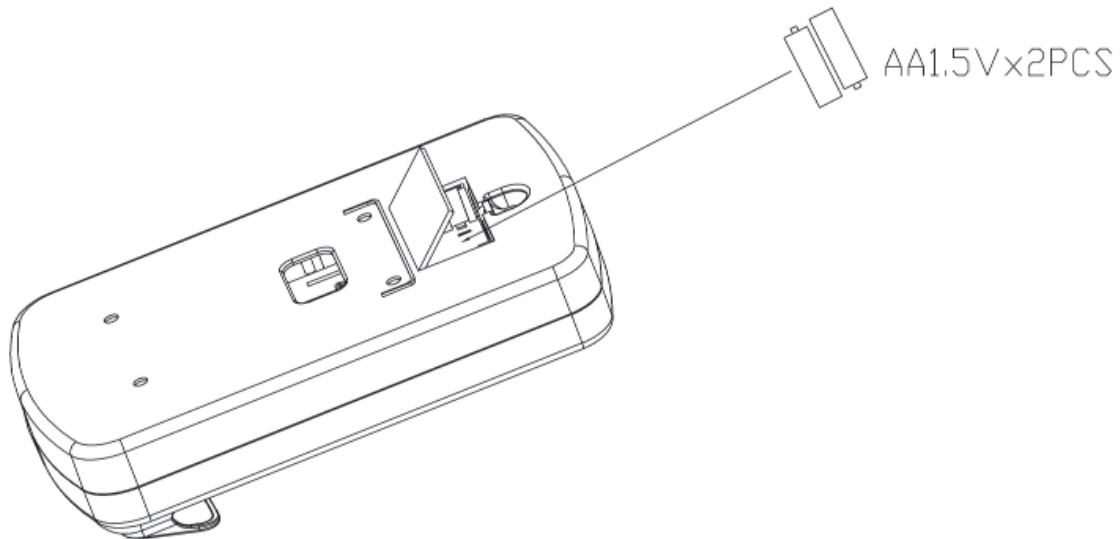

3.4 First Steps

As soon as the console is switched on, the display lights up completely (Fig. 1) and a long signal sounds. The console then enters Standby mode and the symbols for Interval 10/20, Interval 20/10, DISTANCE Target Program and PULSE (heart rate) are displayed in sequence (fig. 2-5).

NOTICE

If the console does not receive any input or signal within four minutes, the console will enter sleep mode.

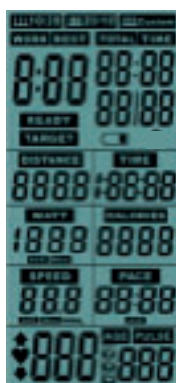

Fig. 1

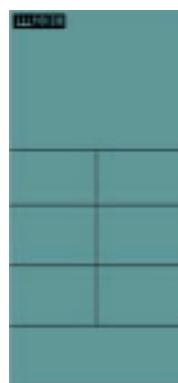

Fig. 2

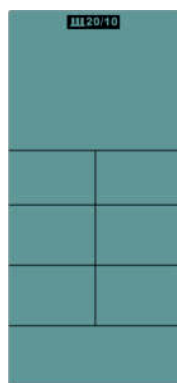

Fig. 3



Fig. 4

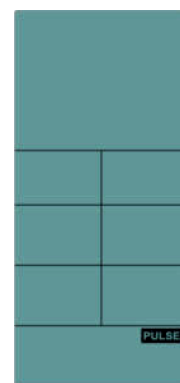

Fig. 5

3.5 Pause programme - Pause mode

1. To pause the programme, press the START/PAUSE button once during the workout.

During the pause mode, the workout data is shown with a "P" on the display (Fig. 6) and a beep sounds for 0.5 seconds every 30 seconds.

NOTICE

If the console does not receive any input within 5 minutes while in pause mode, the console goes into standby mode.

2. To resume, press the START/PAUSE key again.

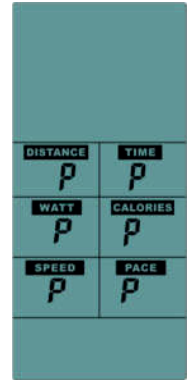

Fig. 6

3.6 End programme - stop mode

To end the programme, press the STOP button once.

- + While pressing, a signal sounds for 0.5 seconds and the console enters stop mode. After 0.5 seconds, the display will first show the DISTANCE, TIME and CALORIES values of the training session (Fig. 7).
- + After 7 seconds a short beep sounds and the maximum values of the training session for WATT, SPEED and PULSE are shown on the display (fig. 8).
- + After 7 seconds a short beep sounds and the average values of the training session for WATT, SPEED and PACE are shown on the display (fig. 9).

NOTICE

The values are displayed three times in total, after which the console goes into standby mode.



Fig. 7



Fig. 8

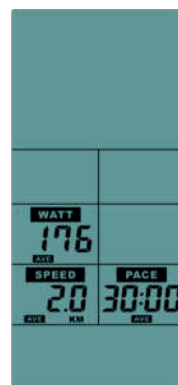

Fig. 9

3.7 Programmes

A total of seven programmes are available:

- + Quick Start:
- + Interval programmes: 3
- + Target programmes: 3
- + Heart rate controlled programme: 1

3.7.1 Quick Start

The quick-start function is ideal if you want to start training immediately.

 **WARNING**

Your training equipment is not a medical device. The heart rate measurement of this equipment may be inaccurate. Various factors can affect the accuracy of the heart rate measurement. The heart rate measurement serves only as a training aid.

 **NOTICE**

Heart rate measurement is only possible with a compatible chest strap.

1. To start the Quick Start function, start exercising in standby mode and press the START/PAUSE button.
2. To pause the training, press the START/PAUSE button once.
3. To resume the training, press the START/PAUSE button again.
4. To end the training, press the STOP button.

3.7.2 Interval 10/20 and Interval 20/10

Two preset programmes are available. These programmes are divided into 8 cycles. You can choose between 10/20 or 20/10 (WORK/REST).

 **WARNING**

Your training equipment is not a medical device. The heart rate measurement of this equipment may be inaccurate. Various factors can affect the accuracy of the heart rate measurement. The heart rate measurement serves only as a training aid.

 **NOTICE**

Heart rate measurement is only possible with a compatible chest strap.

1. To start a preset interval training, press the respective button and confirm with the ENTER button.

A countdown counts down from 3 to 0 and the first interval starts.

The respective interval time is counted down, all other values are counted up.

When an interval (WORK/REST) is completed, one cycle is added to the display.

2. To pause the programme, press the START/PAUSE button once.
3. To resume the programme, press the START/PAUSE button again.
4. To end the programme, press the STOP button or finish the training.

3.7.3 Interval Custom

 **WARNING**

Your training equipment is not a medical device. The heart rate measurement of this equipment may be inaccurate. Various factors can affect the accuracy of the heart rate measurement. The heart rate measurement serves only as a training aid.

 **NOTICE**

Heart rate measurement is only possible with a compatible chest strap.

1. To select the custom interval programme, press the respective button.
2. To set the number of cycles (1-20), press the UP or DOWN buttons and confirm with the ENTER button.
3. To set the time for the WORK sequence (0:05-30:00), press the UP or DOWN buttons and confirm with the ENTER button.
4. To set the time for the REST sequence (0:05-30:00), press the UP or DOWN buttons and confirm with the ENTER button.

A countdown counts down from 3 to 0 and the first interval starts.

The respective interval time is counted down, all other values are counted up.

When an interval (WORK/REST) is completed, one cycle is added to the display.

5. To pause the programme, press the START/PAUSE button once.
6. To resume the programme, press the START/PAUSE button again.
7. To end the programme, press the STOP button or finish the training.

3.7.4 Target Time, Target Distance and Target Calories

1. To select one of the target programmes, press the respective button
2. To set the target value, press the UP or DOWN button and confirm with ENTER.

The target programme starts.

The set value is counted down, all other values are counted up.

3. To pause the programme, press the START/PAUSE button once.
4. To resume the programme, press the START/PAUSE button again.
5. To end the programme, press the STOP button or finish the training.

3.7.5 Target HR

 **WARNING**

Your training equipment is not a medical device. The heart rate measurement of this equipment may be inaccurate. Various factors can affect the accuracy of the heart rate measurement. The heart rate measurement serves only as a training aid.

 **NOTICE**

Heart rate measurement is only possible with a compatible chest strap.

1. To select the heart rate programme, press the respective button.
2. To set your age (11-99), press the UP or DOWN button and confirm with the ENTER button.
3. Select either 65%, 85% or your own target heart rate with the UP or DOWN buttons and confirm with the ENTER button.
- 3.1. If you want to set your own target heart rate, adjust the target heart rate with the UP or DOWN buttons and confirm with the ENTER button.
4. To pause the programme, press the START/PAUSE button once.
5. To resume the programme, press the START/PAUSE button again.
6. To end the programme, press the STOP button or finish the training.

 **NOTICE**

- + If your heart rate deviates by more than 10% from the set value, an arrow symbol in the display indicates that you should adjust your heart rate.
- + If your heart rate matches or exceeds the set value, you will hear three beeps every second. If your heart rate has not decreased after 10 repetitions, a beep will sound for one second and the console will go into standby mode.
- + If no heart rate signal is received after 30 seconds, a signal will sound for one second and the console will go into standby mode.

4.1 General Instructions

⚠ WARNING

- + The storage location should be chosen so that improper use by third parties or children can be prevented.
- + If your equipment does not have transportation wheels, the equipment must be disassembled before transportation.

▶ ATTENTION

- + Make sure that the equipment is protected from moisture, dust and dirt in the selected storage location. The storage location should be dry and well ventilated and have a constant ambient temperature between 10°C and 35°C.

4.2 Transportation Wheels

▶ ATTENTION

If you want to transport your equipment over particularly sensitive and soft floor coverings, such as parquet, planks or laminate, lay out the transport route with cardboard or similar to avoid possible floor damage.

1. Stand behind the equipment and lift it until the weight is transferred to the transportation wheels. After that, you easily can move the equipment to a new position. For long transport distances the equipment should be disassembled and safely packed.
2. Select the new location by following the instructions in the section of this manual.

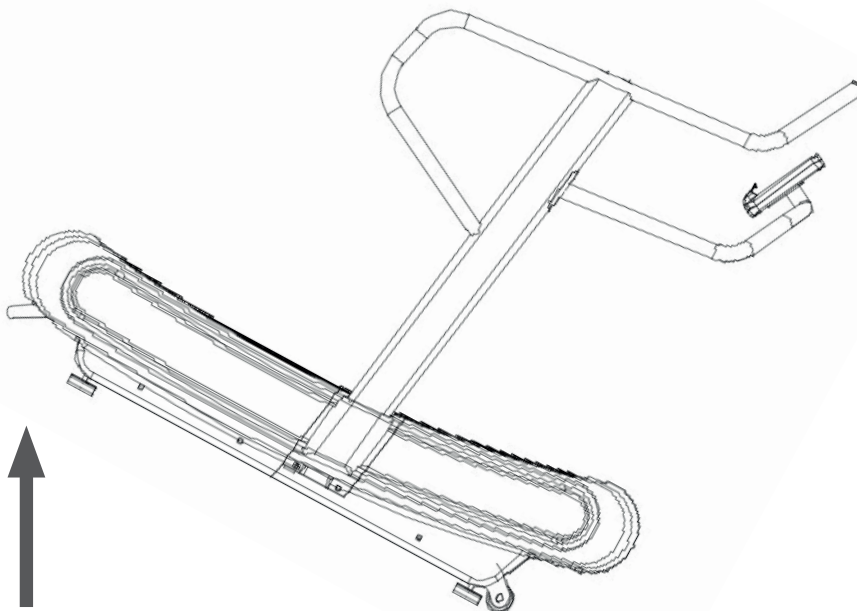

5.1 General Instructions



WARNING

- + Do not make any improper changes to the equipment.



CAUTION

- + Damaged or worn components may affect your safety and the life of the equipment. Therefore, immediately replace damaged or worn components. In such a case, contact the contract partner. The equipment must not be used until it has been repaired. If necessary, use only original spare parts.

► ATTENTION

- + In addition to the instructions and recommendations for maintenance and care given here, additional service and/or repair work may be necessary; this must only be carried out by authorised service technicians.

5.2 Faults and Fault Diagnosis

The equipment undergoes regular quality controls during production. Nevertheless, faults or malfunctions may occur. Frequently, individual parts are responsible for these disturbances, an exchange is usually sufficient. Please refer to the following overview for the most common errors and how to correct them. If the equipment still does not function properly, contact your contract partner.

Fault	Cause	Solution
Display is blank/is not working	<ul style="list-style-type: none"> + Interrupted power connection + Loose cable connections 	<ul style="list-style-type: none"> + Check cable connections
No pulse display	<ul style="list-style-type: none"> + Sources of interference in the room + unsuitable chest strap + Wrong position of chest strap + Chest strap defective or battery empty + Pulse display defective 	<ul style="list-style-type: none"> + Eliminate sources of interference (e.g. mobile phone, WLAN, lawn mower and vacuum cleaner robot, etc. ...) + Use a suitable chest strap (see RECOMMENDED ACCESSORIES). + Reposition chest strap and/or moisten electrodes + Changing batteries + Check if pulse display by hand pulse possible

5.3 Maintenance and Inspection Calendar

To avoid damage from body sweat, the equipment must be cleaned with a damp towel (no solvents!) after each training session.

The following routine tasks must be performed at the specified intervals:

Part	Weekly	Monthly	Quarterly
Display console	C	I	
Plastic covers	C	I	
Screws and cable connections			I
Legend: C = clean; I = inspect			

6 DISPOSAL

At the end of its operational life, this equipment cannot be disposed of in normal household waste. Instead, it must be disposed of via an recycling centre. Further information can be obtained from your local authority's recycling service.



The materials can be recycled as per their symbols. Through the reuse, recycling of materials or other forms of recovery of old equipment, you make an important contribution to the protection of the environment.

7 RECOMMENDED ACCESSORIES

To make your training experience even more efficient and pleasant, we recommend that you add suiting accessories to your fitness equipment. For treadmills this could for example be a **floor mat**, which makes your fitness equipment stand more securely and also protects the floor from sweat or **silicone spray** to keep moving parts in good shape and lubricate the running mat. Furthermore, there are additional **handrails** available for some treadmills.

If you have purchased a fitness machine with pulse training and want to train your heart rate, we strongly recommend that you use a compatible chest strap, as this ensures optimum transmission of the heart rate.

Our range of accessories offers the highest quality and makes training even better. If you would like to find out more about compatible accessories, please go to the detail page of the product in our webshop (the easiest way is to enter the article number in the search field above) and go to the recommended accessories on this page. Alternatively, you can use the QR code provided. Of course, you can also contact our customer service: by telephone, e-mail, in one of our branches or via our social media channels. We will be happy to advise you!



floor mat



chest strap

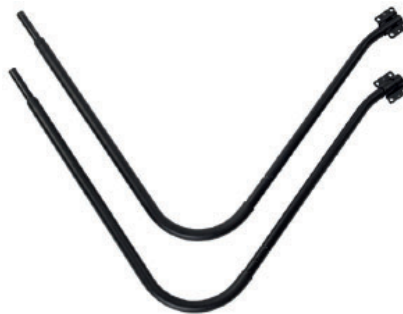

handrails

7.1 Serial Number and Model Name

In order to provide you with the best possible service, please have the model name, article number, serial number, exploded drawing and parts list ready. The corresponding contact options can be found in chapter 10 of this operating manual.

NOTICE

The serial number of your equipment is unique. It's located on a white sticker. The exact position of this sticker is shown in the following illustration.



Enter the serial number in the appropriate field.

Serial number:

Brand / Category:

Model Name:

SKU:

8.1 Parts List

No.	Name	Qty.	No.	Name	Qty.
1	Main frame	1	32	Driving wheel plate -Aluminum	1
2	Upright post - right side	1	33	Aluminum slat fixing belt (new Kevlar)	2
3	Upright post - left side	1	34	EVA mat - t2.0×50×3600	2
4	Console frame	1	35	Front plastic side cover - right side	1
5	Rear main frame lifting handle	1	36	Front plastic side cover - left side	1
6	Handrail - right side	1	37	Rear plastic side cover - right side	1
7	Curve cover fixing support - right side	1	38	Rear plastic side cover - left side	1
8	Curve cover fixing support - left side	1	39	Upright post side cover - right side	1
9	Front foot- right side	1	40	Upright post side cover - left side	1
10	Front foot- left side	1	41	Front foot stop	4
11	Rear foot- right side	1	42	EVA mat - t5.0×70×3000	1
12	Rear foot- left side	1	43	Top section resistance cable L - 1150mm	1
13	Magnet bracket	1	44	Top section resistance cable L - 450	1
14	Adjustable resistor fixing bracket	1	45	Round magnet	4
15	Rear roller adjustable bracket	2	46	Brake tension spring	1
17	Curve cover reinforcement plate - right side	1	47	Aluminum slat	60
18	Curve cover reinforcement plate - left side	1	48	Double hole Washer - t1.5*20*10	120
19	Adjustable resistor fixing plate	2	49	Manual adjustable handle	1
20	Curve cover fixing bracket	2	50	Stall adjustable assembly	1
21	Magnet covered plate	2	51	Manual adjustable handle cover	1
22	Pulley wheel axle weldment	1	52	Manual adjustable handle side cover	1
23	Driving wheel axle weldment	1	53	Stall adjustable post	2
24	Front roller	1	54	Ordinary cylindrical spring	1
25	Rear roller	1	55	Console	1
26	Motor belt - 380PJ6	1	56	2 pin connected wire L-1250mm	1
27	Motor belt - 260PJ6	1	57	VR 3 pin connected wire L-1250mm	1
28	Moving wheels	2	58	2 pin connected wire L-950mm	1
29	Wheel and axle	2	59	VR 3 pin connected wire L-950mm	1
30	Driving pulley wheel -front	1	60	3 pin connected wire L-500mm	1
31	Driving wheel axle	1	61	2 pin - plug bottom section connected wire	1

62	Resistor VR	1	89	Allen head C.K.S half thread bolt M10×25×15	4
63	Screw fixing buckle	4	90	Hex head locknut M10	4
64	Screw fixing plate	10	91	Flat washer Φ10	4
65	T shape siderail guider	6	92	Allen countersunk head full thread screw M6×15	4
66	Allen head C.K.S full thread bolt - M8*15	12	93	Hexagon head full thread bolt M8×30	2
67	Allen head C.K.S full thread bolt - M8*20	24	94	Hexagon nut M8	2
68	Hexagon head half thread bolt - M8*65*20	98	95	Allen head C.K.S step bolt M6×50×36	1
69	Hexagon socket head full thread bolt - M8*65	12	96	Phillip pan head self-tapping screw ST3×10	2
70	Bearing 608ZZ	124	97	Phillip head C.K.S self-tapping screw ST4×16	22
71	Sleeveφ12*φ8.1*18.4	98	98	Phillip pan head full thread bolt M5*15	240
72	Sleeveφ12*φ8.1*14	12	99	Phillip head C.K.S full thread screw M4×10	3
73	Guiding pulley wheel	12	100	Hex head locknut M4	3
74	Flat washer φ8	110	101	Hexagon socket head full thread bolt M8×45	4
75	Internal Circlip φ23	12	102	Flat plug Φ38×t1.5	2
76	Deep groove ball bearing 6201ZZ	4	103	Hexagon socket head full thread bolt M8×15	4
77	One way bearing CSK12P	1	104	Hex head locknut M8	110
78	Allen head C.K.S half thread bolt M8×55×20	9	105	Handrail - left side	1
79	Allen head C.K.S full thread bolt M8×25	4	106	End cover t1.2×φ31	4
80	Curve washer Φ8.5×R25×t2.0	4	107	Hexagon lock nylon nut M6	1
81	Phillip countersunk head self-tapping screw	24	108	Flat washer Φ6	1
82	Phillip countersunk head self-tapping screw	20	109	Spring washer φ6	240
83	Phillip head C.K.S full thread screw M5×10	4	110	Water holder	1
85	Hexagon socket head full thread bolt M8×75	2	111	Philips Pan head full thread screw M4x16	2
86	Allen head C.K.S half thread bolt M8×30×20	2			
87	Hex head locknut M8	3			
88	Flat washer Φ8	3			

8.2 Exploded Drawing

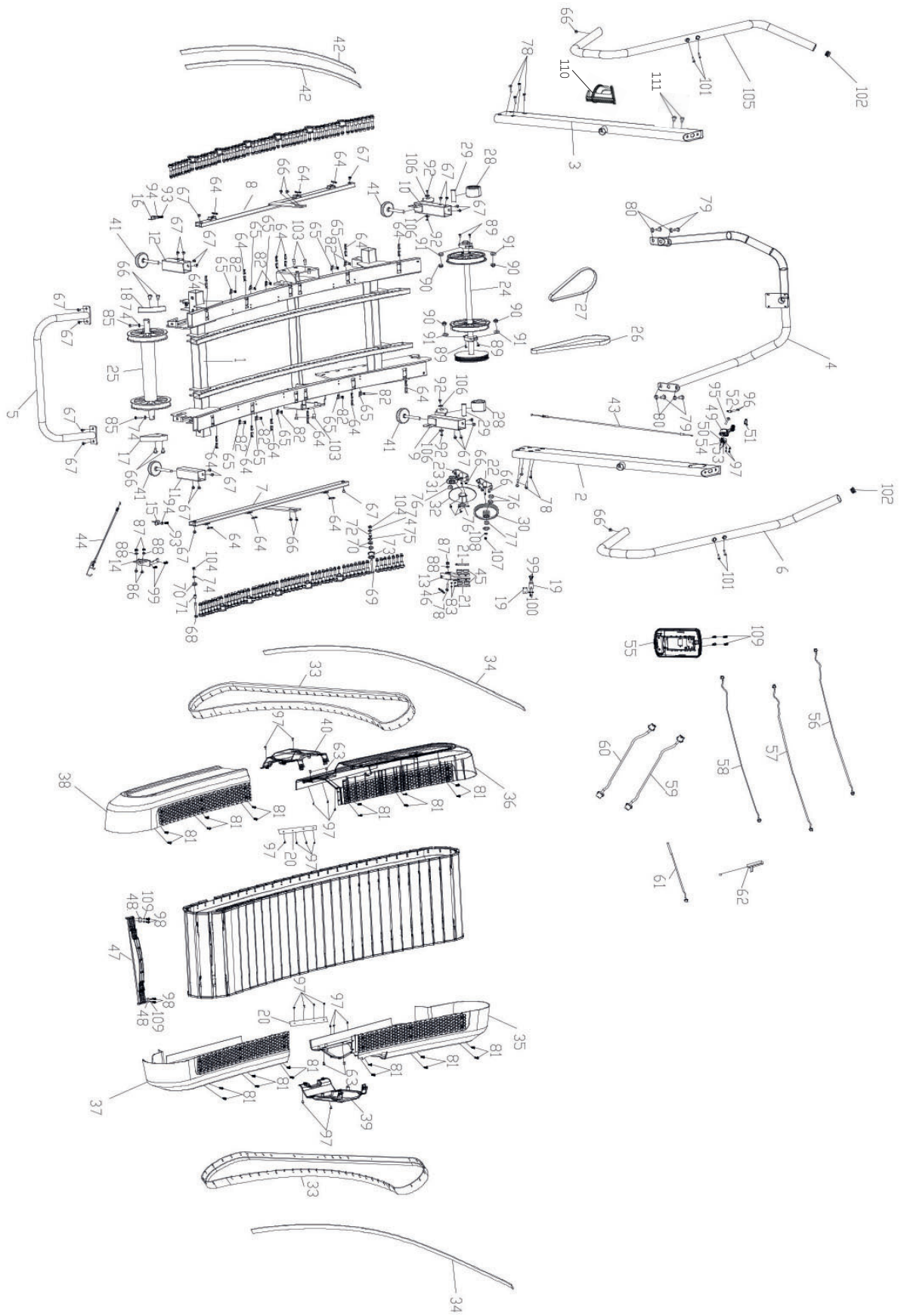

Products from TAURUS® are subject to strict quality control. However, if a fitness equipment purchased from us does not work perfectly, we take it very seriously and ask you to contact our customer service as indicated. We are happy to help you by phone via our service hotline.

Error Descriptions

Your fitness equipment is developed for long-term, high-quality training. However, should a problem arise, please first read the operating instructions. For further assistance, please contact your contract partner or call our service hotline. To ensure your problem is solved as quickly as possible, please describe the defect as exactly as possible.

In addition to the statutory warranty, we provide a warranty for every fitness equipment purchased from us according to the following provisions.

Your statutory rights are not affected.

Warranty

The warranty is the first/original buyer.

Warranty periods

The following warranty periods begin on delivery of the fitness equipment.

Warranty period

The warranty periods, shown on our web shop, begin on delivery of the fitness equipment. The respective warranty periods for your equipment can be found on its product website.

Repair Costs

According to our choice, there will either be a repair, a replacement of individual damaged parts or a complete replacement. Spare parts, that have to be mounted while assembling the equipment, have to be replaced by the warranty holder personally and are not a part of repair. After the expiration of the warranty period, the responsibility for parts costs, repair costs, installation costs and delivery costs lies with the warranty holder.

The terms of use are defined as follows:

- + Home use: solely for private use in private households up to 3 hours per day
- + Semi-professional use: up to 6 hours per day (e. g. rehabilitation centres, hotels, clubs, company gyms)
- + Professional use: more than 6 hours per day (e. g. commercial gyms)

Warranty Service

Within the warranty period, equipment which develops faults as a result of material or manufacturing defects, will be repaired or replaced at our discretion. Ownership of equipment or parts of equipment which have been replaced is transferred to us. The warranty period is not extended nor does a new warranty period begin following repair or replacement under the warranty.

Warranty Conditions

For the warranty to be valid, the following steps must be taken:

Please contact our customer service by email or phone. If the product under warranty has to be sent in for repair, the seller bears costs. After expiry of the warranty, the buyer bears the costs of transport and insurance. If the fault is covered by our warranty, you will receive a new or repaired equipment in return.

Warranty claims are invalid in case of damage resulting from:

- + misuse or improper handling
- + environmental influences (moisture, heat, electrical surge, dust, etc.)
- + failure to follow the current safety measures for the equipment
- + failure to follow the operating instructions
- + use of force (e. g. hitting, kicking, falling)
- + interventions which were not carried out by one of our authorized service centres
- + unauthorised repair attempts

Proof of Purchase and Serial Number

Please make sure that you are able to provide the appropriate receipt when claiming on your warranty. So that we can clearly identify the model of your equipment, and for the purposes of our quality control, you will need to give the serial number of your equipment, when contacting the service team. Where possible please have your serial number and your customer number ready when you call our service hotline. It will help us to deal with your request swiftly.

If you cannot find the serial number on your fitness equipment, our service team is at your disposal to offer further information.

Service outside of the Warranty Period

We are also happy to issue an individual cost estimate if there is a problem with your fitness equipment after the warranty has expired, or in cases which do not fall under the terms of the warranty, e. g. normal wear and tear. Please contact our customer service team to find a quick and cost-effective solution to your problem. In such a case you will be responsible for the delivery costs.

Communication

Many problems can be solved just by speaking to us as your specialist supplier. We know how important it is to you as a user of the fitness equipment to have problems solved quickly and simply, so you can enjoy working out with minimal interruption. For that reason, we also want to resolve your queries quickly and in a straightforward manner. Thus, please always keep your customer number and the serial number of the faulty equipment handy.

10 CONTACT

DE	DK	UK
<p>TECHNIK</p> <p>☎ +49 4621 4210-900 ☎ +49 4621 4210-698 ✉ technik@fitshop.de 🕒 Öffnungszeiten entnehmen Sie unserer Homepage.</p> <p>SERVICE</p> <p>☎ 0800 20 20277 (kostenlos) ☎ 04621 4210 - 0 ✉ info@fitshop.de 🕒 Öffnungszeiten entnehmen Sie unserer Homepage: https://stg.fit/statita</p>	<p>TEKNIK OG SERVICE</p> <p>☎ 80 90 16 50 +49 4621 4210-945 ✉ info@fitshop.dk 🕒 Åbningstider kan findes på hjemmesiden: https://stg.fit/statit7</p>	<p>CUSTOMER CARE</p> <p>☎ +44 141 737 2249 or +44 141 876 3972 ✉ customercare@fitshop.co.uk 🕒 You can find the opening hours on our homepage: https://stg.fit/statitd</p>
	FR	BE
	<p>TECHNIQUE & SERVICE</p> <p>☎ +33 (0) 189 530984 +49 4621 42 10 933 ✉ info@fitshop.fr 🕒 Vous trouverez les heures d'ouverture sur notre site Internet: https://stg.fit/statit4</p>	<p>TECHNIQUE & SERVICE</p> <p>☎ 02 732 46 77 +49 4621 4210 933 ✉ info@fitshop.be 🕒 Vous trouverez les heures d'ouverture sur notre site Internet: https://stg.fit/statit8</p>
ES	NL	INT
<p>TECNOLOGÍA Y SERVICIOS</p> <p>☎ 911 238 029 ✉ info@fitshop.es 🕒 Consulta nuestro horario de apertura en la página web: https://stg.fit/statit5</p>	<p>TECHNISCHE DIENST & SERVICE</p> <p>☎ +31 172 619961 ✉ service@fitshop.nl 🕒 De openingstijden vindt u op onze homepage: https://stg.fit/statit3</p>	<p>TECHNICAL SUPPORT & SERVICE</p> <p>☎ +49 4621 4210-944 ✉ service-int@fitshop.de 🕒 You can find the opening hours on our homepage: https://stg.fit/statita</p>
PL	AT	CH
<p>DZIAŁ TECHNICZNY I SERWIS</p> <p>☎ 22 307 43 21 +49 4621 42 10-948 ✉ info@fitshop.pl 🕒 Godziny otwarcia można znaleźć na stronie głównej: https://stg.fit/statit6</p>	<p>TECHNIK & SERVICE</p> <p>☎ 0800 20 20277 (Freecall) +49 4621 42 10-0 ✉ info@fitshop.at 🕒 Öffnungszeiten entnehmen Sie unserer Homepage: https://stg.fit/statitb</p>	<p>TECHNIK & SERVICE</p> <p>☎ 0800 202 027 +49 4621 42 10-0 ✉ info@fitshop.ch 🕒 Öffnungszeiten entnehmen Sie unserer Homepage: https://stg.fit/statit9</p>

Please find a detailed overview including address and opening hours for all stores of Fitshop UK on the following website:

www.fitshop.co.uk/storelocator

WE LIVE FITNESS

WEBSHOP AND SOCIAL MEDIA

The Fitshop Group is Europe's largest specialist for home fitness equipment with currently 70 stores and one of the world's most renowned online mail order companies for fitness equipment.

Fitshop UK is part of the Fitshop Group. Private customers order via the 25 web shops in the respective national language or have their desired equipment assembled on site. In addition, the company supplies fitness studios, hotels, sports clubs, companies and physio practices with professional equipment for endurance and strength training.

The Fitshop group offers a wide range of fitness equipment from renowned manufacturers, high-quality in-house developments and comprehensive services, such as a build-up service and sports scientific advice before and after the purchase. The company employs numerous sports scientists, fitness trainers and competitive athletes.

Visit us also on our social media platforms or our blog!



<https://www.fitshop.co.uk>
www.fitshop.co.uk/blog



www.facebook.com/fitshop.co.uk



www.instagram.com/fitshop_uk



www.youtube.com/@fitshop_uk

TAURUS

 cardiostrong

BODYCRAFT

BodyMax

Notes

TAURUS[®]

TAURUS ELITE RUN