

TAURUS®

Assembly and Operating Instructions



max. 200 kg



~ 60 Min.



174 kg

L 230 | W 91 | H 163

CVTM2522.02.05

SKU: CVTM2522

Treadmill T10.5 Pro

Content

1	GENERAL INFORMATION	7
1.1	Technical Data	7
1.2	Personal Safety	8
1.3	Electrical Safety	9
1.4	Set-Up Place	10
2	ASSEMBLY	11
2.1	General Instructions	11
2.2	Scope of Delivery	12
2.3	Assembly	13
3	OPERATING INSTRUCTIONS	18
3.1	Console display	18
3.2	Button functions	19
3.3	Fitness programmes	20
3.3.1	Quick Start	20
3.3.2	Manual programme	21
3.3.3	Low speed programme	21
3.3.4	Pre-set programmes	22
3.3.5	User-defined programmes	24
3.3.6	Heart rate-oriented programmes	25
3.3.7	Training programme	26
3.4	Body fat test	27
3.5	Bluetooth and fitness apps	27
4	STORAGE AND TRANSPORT	29
4.1	General Instructions	29
4.2	Transportation Wheels	29
5	TROUBLESHOOTING, CARE AND MAINTENANCE	30
5.1	General Instructions	30
5.2	Faults and Fault Diagnosis	30
5.3	Care and Maintenance	31
5.3.1	Adjusting the Running Mat	31
5.3.2	Re-tensioning the Running Mat	32
5.3.3	Lubricating the Running Mat	32
5.4	Maintenance and Inspection Calendar	33
6	DISPOSAL	33

7	RECOMMENDED ACCESSORIES	34
8	ORDERING SPARE PARTS	35
8.1	Serial Number and Model Name	35
8.2	Parts List	36
8.3	Parts List (Optional Hand Rails)	41
8.4	Exploded Drawing	42
8.5	Exploded Drawing (Optional Hand Rails)	43
9	WARRANTY	44
10	CONTACT	46

Dear customer,

Thank you for choosing a high-quality equipment of the brand Taurus®. Taurus® offers sports and fitness equipment for the sophisticated home sport and the equipment of fitness studios and business customers. With Taurus® fitness equipment, the focus is on what sport is all about: maximum performance! Therefore, the equipment is developed in close consultation with athletes and sports scientists. Because athletes know best what makes perfect fitness equipment.

Further information can be found at www.sport-tiedje.com.

Intended Use

The equipment may only be used for its intended purpose.

This fitness equipment is suitable for home use, semi-professional use and commercial or professional use. The semi-professional sector includes, for example, institutional facilities such as hospitals, schools, hotels and associations. Professional use refers to commercial use, e.g. in a fitness studio.

Disclaimer



©2011 Taurus® is a registered brand of the company Sport-Tiedje GmbH. All rights reserved. Any use of this trademark without the explicit written permission of Sport-Tiedje is prohibited.

Product and manual are subject to change. Technical data can be changed without advance notice.

ABOUT THIS MANUAL

Please carefully read the entire manual before installation and first use. The manual will help you to quickly set up the system and explains how to safely use it. Make sure that all persons exercising with the equipment (especially children and persons with physical, sensory, mental or motor disabilities) are informed about this manual and its contents in advance. In case of doubt, responsible persons must supervise the use of the equipment.

Due to ongoing changes and software optimisations, the manual may have to be updated. If you notice any discrepancies during assembly or use, please refer to the manual uploaded to the webshop. The latest manual is always available there.



This equipment has been manufactured according to the latest safety knowledge. As far as possible, potential safety hazards which could cause injury have been eliminated. Make sure to carefully follow the instructions and that all parts are securely in place. If required, read through the instructions again to correct any mistakes.

Please pay close attention to the safety and maintenance instructions given here. The contract partner cannot be held liable for damage to health, accidents or damage to the equipment when it is not used in accordance with these instructions.

The following safety instructions may appear in this manual:

► **ATTENTION**

This notice indicates potentially hazardous situations which, if not avoided, may result in property damage.

⚠ **CAUTION**

This notice indicates potentially hazardous situations which, if not avoided, may result in slight or minor injuries!

⚠ **WARNING**

This notice indicates potentially hazardous situations which, if not avoided, may result in death or serious injuries!

⚠ **DANGER**

This notice indicates potentially hazardous situations which, if not avoided, will result in death or serious injuries!

ⓘ **NOTICE**

This notice indicates further useful information.

Retain these instructions in a safe place for future reference, maintenance or when ordering replacement parts.

1.1 Technical Data

LED display of

- + speed in km/h
- + training time in min
- + training distance in km
- + calories burnt in kcal
- + heart rate (when using the hand sensors or a chest strap)
- + incline in %

Motor output:	4 HP continuous output (AC motor)
Speed range:	0.5 - 25 km/h
Speed hot keys:	8
Incline range:	0 - 15 %
Incline hot keys:	8
Total number of training programmes:	33
Pre-set programmes:	20
Manual programmes:	1
Heart rate-oriented programmes:	3
User-defined programmes:	4

Running surface size (L x W): 160 cm x 60 cm

Weight and dimensions:

Article weight (net, without packaging):	174 kg
Packaging dimensions (L x W x H):	226 cm x 105 cm x 51,5/41 cm
Set-up dimensions (L x W x H):	230 cm x 91 cm x 163 cm
Maximum user weight:	200 kg

1.2 Personal Safety

DANGER

- + Before you start using the equipment, you should consult your physician that this type of exercise is suitable for you from a health perspective. Particularly affected are persons who: have a hereditary disposition to high blood pressure or heart disease, are over the age of 45, smoke, have high cholesterol values, are overweight and/or have not exercised regularly in the past year. If you are under medical treatment that affects your heart rate, medical advice is absolutely essential.
- + Note that excessive training can seriously endanger your health. Please also note that heart rate monitoring systems can be inaccurate. If you notice any signs of weakness, nausea, dizziness, pain, shortness of breath, or other abnormal symptoms, stop exercising immediately and seek advice from your doctor if necessary.

WARNING

- + This equipment may not be used by children under the age of 14.
- + Children should not be allowed unsupervised access to the equipment.
- + Persons with disabilities must have a medical license and must be under strict observation when using the equipment.
- + The equipment is strictly for use by one person at a time.
- + If your equipment provides a safety key, the clip of the safety key must be attached to your clothing before starting your training. In the event of a fall, the EMERGENCY STOP of the equipment can be initiated.
- + Keep your hands, feet and other body parts, hair, clothing, jewellery and other objects well clear of moving parts.
- + During use, wear suitable sports clothing rather than loose or baggy clothing. When wearing sports shoes, make sure they have suitable soles, preferably made of rubber or other non-slip materials. Shoes with heels, leather soles, studs or spikes are unsuitable. Never exercise barefoot.

CAUTION

- + If your equipment needs to be connected to the power supply with a mains cable, make sure that the cable is not a potential tripping hazard.
- + Make sure that nobody is within the range of motion of the equipment during training so as not to endanger you or other persons.

ATTENTION

- + Do not insert any objects of any kind into the openings of the device.

1.3 Electrical Safety

DANGER

- + In order to reduce the risk of an electric shock, always unplug the equipment from the mains socket immediately after your workout, before assembly or dismantling, and before maintenance or cleaning. Do not pull on the cable.

WARNING

- + Do not leave the equipment unattended while the mains cable is plugged into the mains socket. During your absence, the mains cable must be removed from the mains socket to prevent improper use by third parties or children.
- + If the mains cable or plug is damaged or defective, contact your contract partner. Until repair, the equipment must not be used.

ATTENTION

- + The equipment requires a mains connection of 220-230 V with 50 Hz mains voltage.
- + The equipment may only be connected directly to an earthed socket using the supplied mains cable. Extension cables must conform to VDE guidelines. Always completely unwind the mains cable.
- + The socket must be protected by a fuse with a minimum fuse rating of "16 A, slow blow".
- + Do not make any changes to the mains cable or the mains plug.
- + Keep the mains cable away from water, heat, oil and sharp edges. Do not route the mains cable underneath the equipment or under a carpet or rug, and do not place any objects on top of it.
- + If your purchased item is equipped with a TFT console, software updates must be carried out regularly. Follow the instructions on the console to perform the update(s).
- + The software systems on gym equipment with TFT consoles are set up only for the pre-installed apps. Do not install any additional apps.

NOTICE

- + The pre-installed apps on TFT consoles are produced and provided by external manufacturers. Sport-Tiedje does not take any responsibility for the availability, functionality or contents of these apps.

1.4 Set-Up Place



WARNING

- + Do not place the equipment in main corridors or escape routes.



CAUTION

- + Make sure that there is a safety area behind the treadmill with a length of at least 2 m and a width at least equal to the width of the treadmill.
- + The training room should be well ventilated during training and not be exposed to any draughts.
- + Choose the place in which to set up the equipment such that there is enough free space/clearance to the front, the rear and to the sides of the equipment.
- + The set-up and mounting surface of the equipment should be flat, loadable and solid.

ATTENTION

- + The device may only be used in one building, in sufficiently tempered and dry rooms (ambient temperatures between 10°C and 35°C). The equipment should not be used outdoors or in rooms with high humidity (over 70%) like swimming pools.
- + A floor protective mat/equipment underlay can help to protect high-quality floor coverings (parquet, laminate, cork, carpets) from dents and sweat and can help to level out slight unevenness.

Recommended free zone:

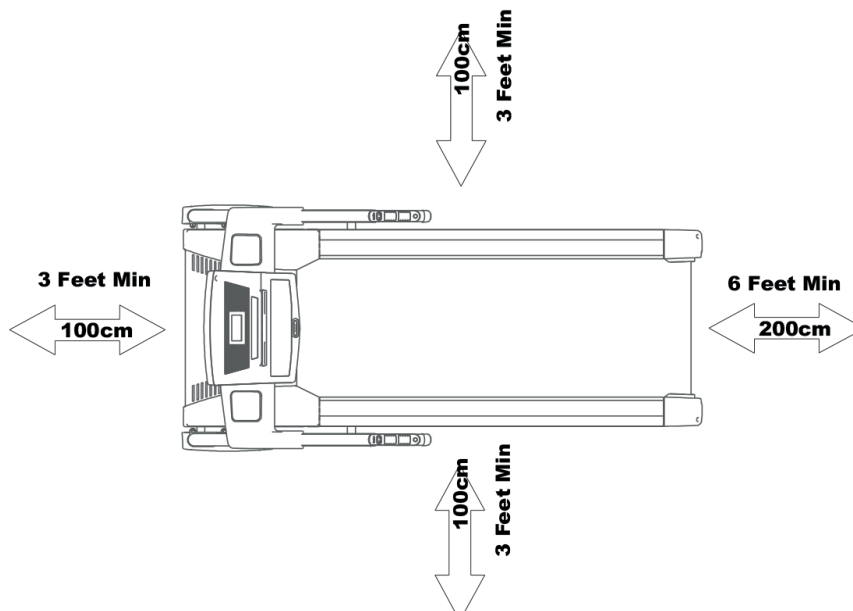

2.1 General Instructions



DANGER

- + Do not leave any tools, packaging materials such as foils or small parts lying around, as otherwise there is a danger of suffocation for children. Keep children away from the equipment during assembly.



WARNING

- + Pay attention to the instructions attached to the equipment in order to reduce the risk of injuries.



CAUTION

- + Ensure to have sufficient room for movement in each direction during assembly.
- + The assembly of the equipment must be carried out by at least two adults. If in doubt, seek the help of a third technically skilled person.



ATTENTION

- + To prevent damage to the equipment and the floor, assemble the equipment on a mat or packaging board.



NOTICE

- + In order to make the assembly as simple as possible, some screws and nuts to be used can already be pre-assembled.
- + Ideally, assemble the equipment at its later set-up place.

2.2 Scope of Delivery

The scope of delivery consist of the following parts. At the beginning, check whether all parts and tools belonging to the device are included in the scope of delivery and whether damage has occurred. In the event of complaints, the contractual partner must be contacted directly.

⚠ CAUTION

If parts of the scope of delivery are missing or damaged, the assembly must not be carried out.

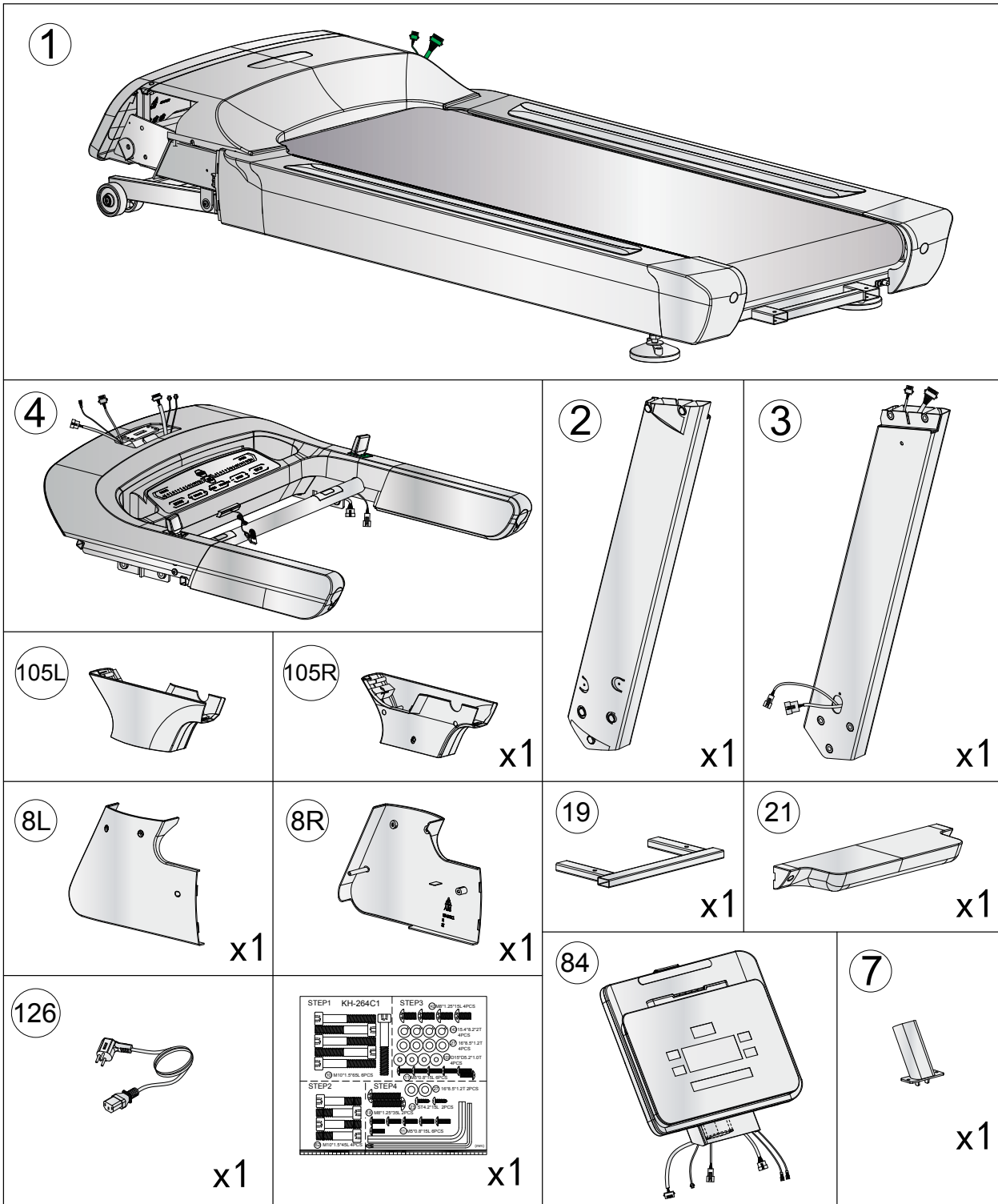

2.3 Assembly

Before assembly, take a close look at the individual assembly steps shown and carry out the assembly in the order given.

NOTICE

- + First loosely screw all parts together and check that they fit properly. Tighten the screws using the tool only when you are instructed to do so.
- + If you have difficulty recognising the graphics, we recommend that you open and/or download the PDF instructions stored in the webshop on your end device (e.g. smartphone, tablet or PC). There you have the option of zooming in closer. Please note that the Adobe Acrobat Reader programme must be installed on your end device in order to open the file.

Step 1: Assembly of the handlebar posts

1. Connect the two cables (121 and 122) with one another.

► **ATTENTION**

Be careful not to pinch the cables in the following step.

2. Fix the two handlebar posts (2 and 3) to the main frame (1) with six allen bolts (10).

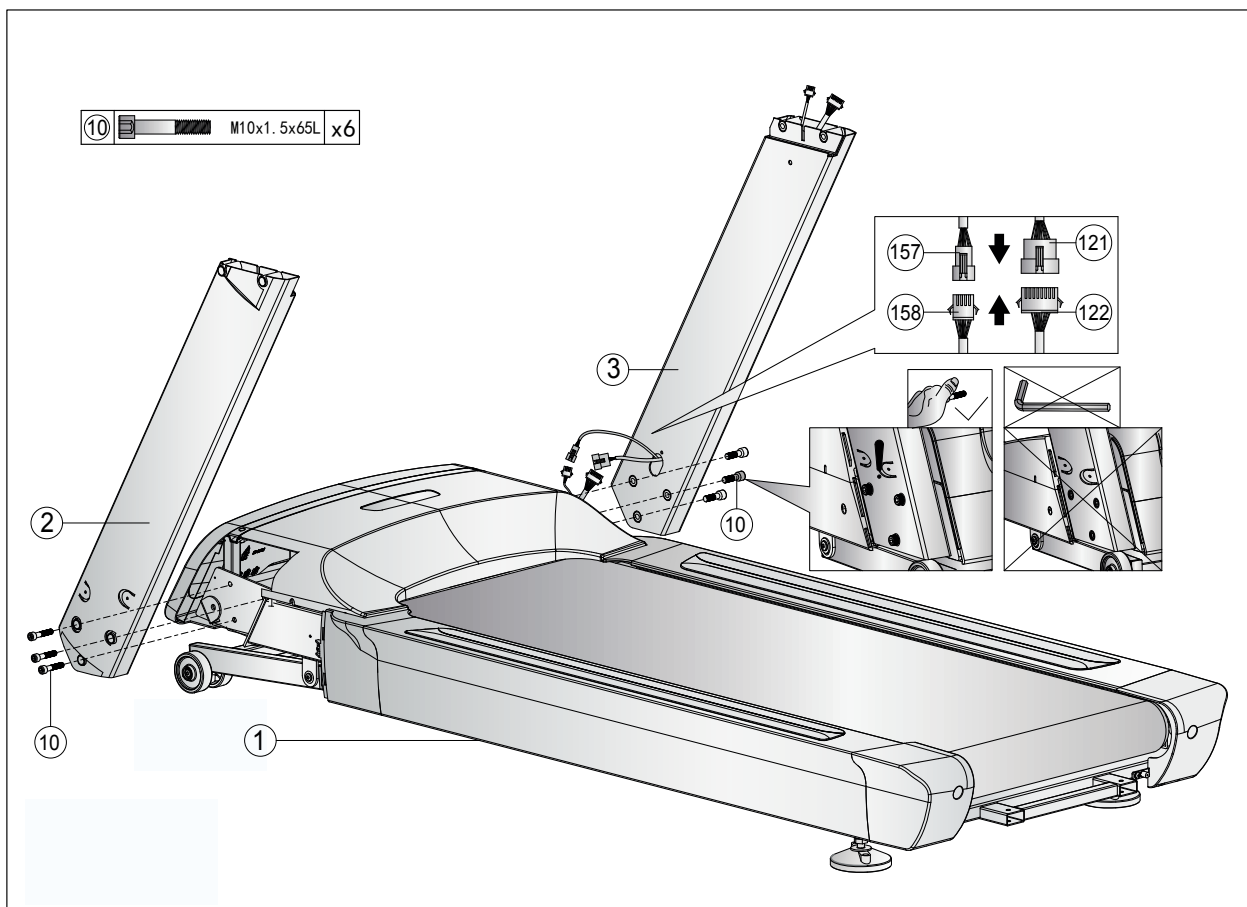

Step 2: Assembly of the handlebar

1. Slide the two covers (105L and 105R) downwards (fig. 2-1).
2. Connect the two cables (120 and 121) with one another (fig. 2-2).

► **ATTENTION**

Be careful not to pinch the cables in the following step.

3. Fix the handlebar (4) to the two handlebar posts (2 and 3) with four allen screws (91).

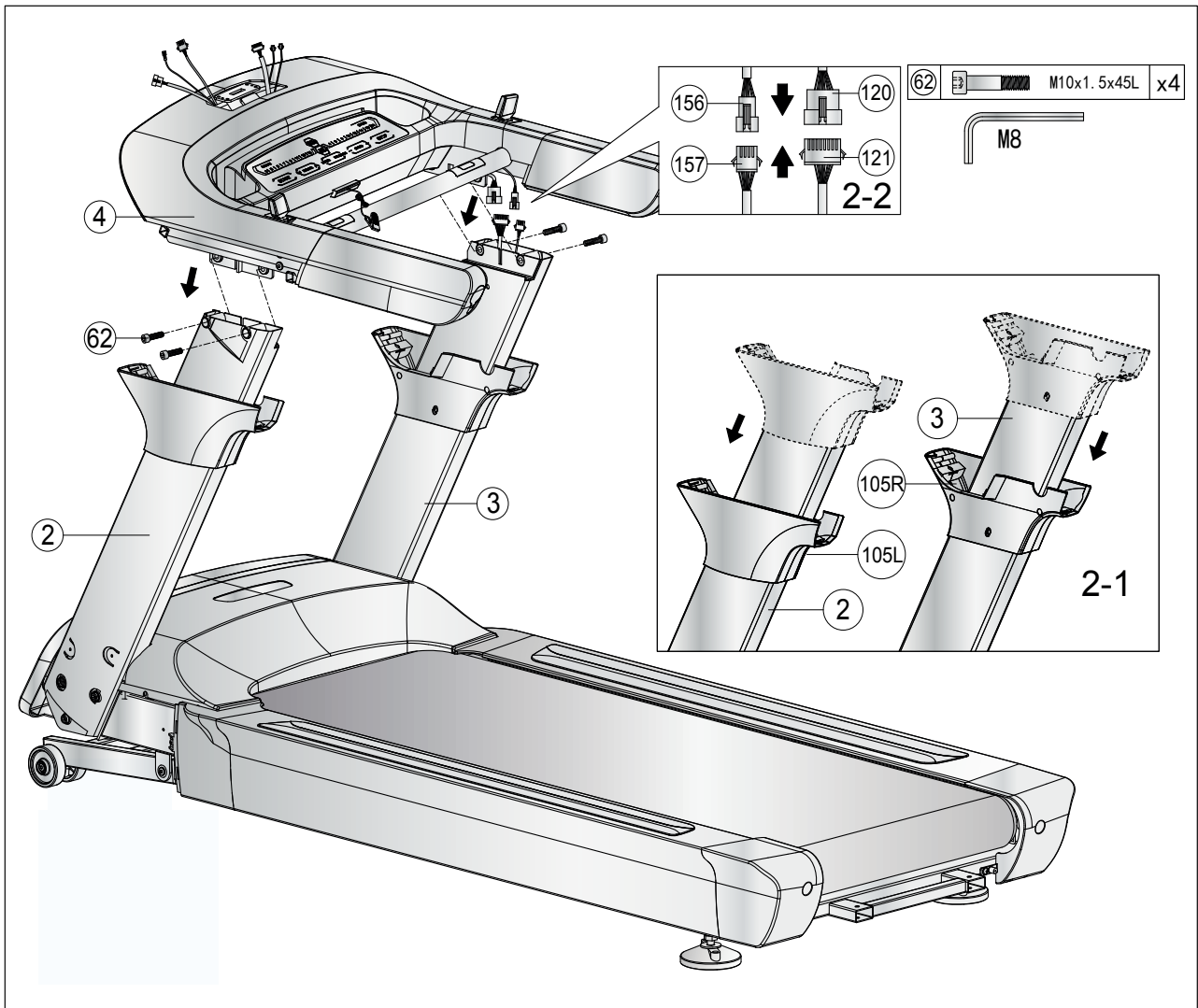

Step 3: Assembly of the console

1. Fix the supporting tube (7) to the handlebar (4) with two allen bolts (142), two spring washers (143) and two flat washers (27) (fig. 3-1).
2. Connect the cables (93, 98, 118 and 120) with their counterparts of the console (84) (fig. 3-2).

► **ATTENTION**

Be careful not to pinch the cables in the following step.

3. Fix the console (84) to the supporting tube (7) with two allen bolts (142), two spring washers (143) and two flat washers (27).
4. Slide the covers (105L and 105R) upwards again and fix them to the handlebar (4) with six cross bolts (11) and four washers (27).

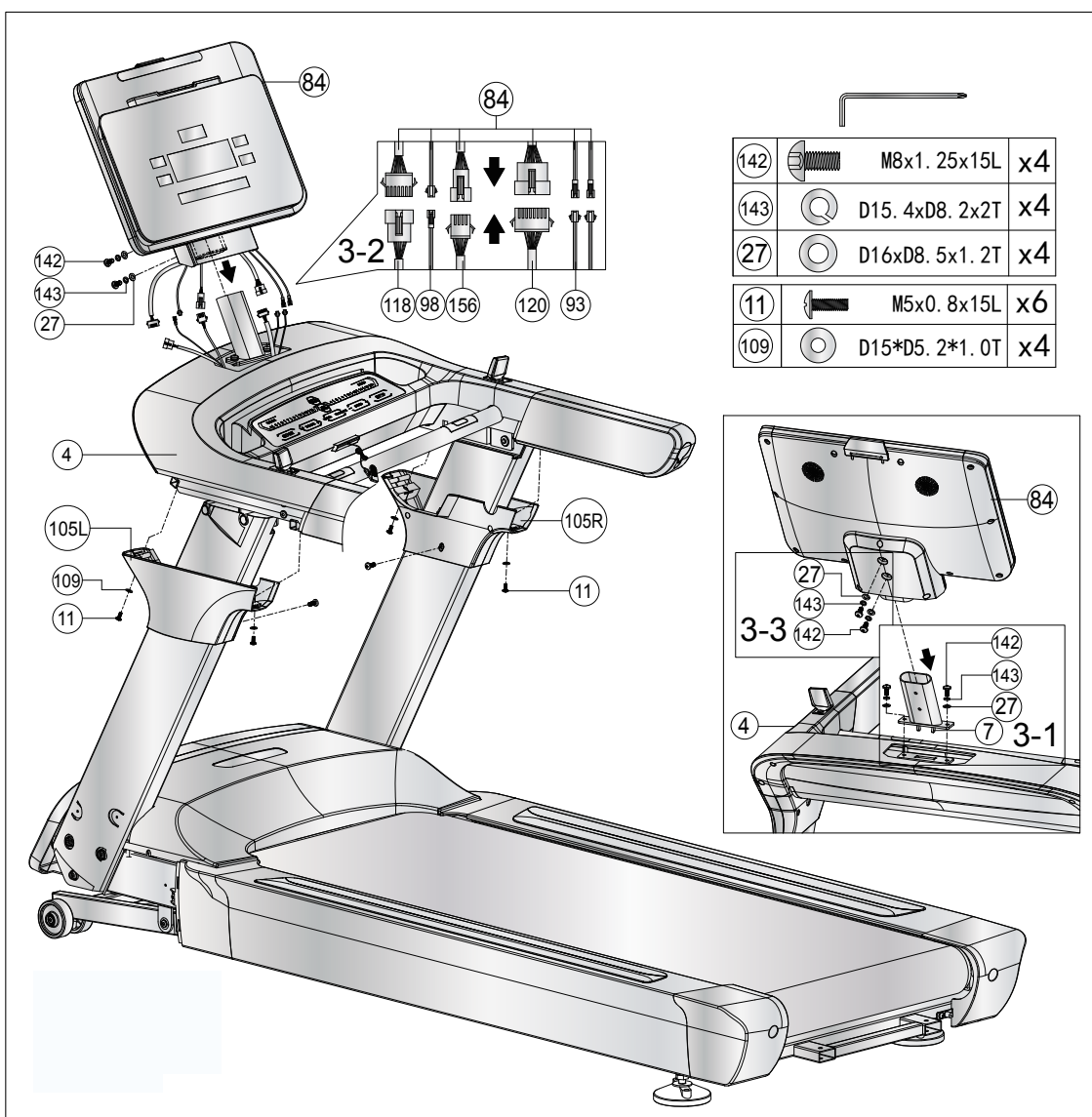

Step 4: Finish the assembly

1. Fix the covers (8L and 8R) to the main frame (1) and to the handlebar posts (2 and 3) with six bolts (11) (fig. 4-1 and 4-2).
2. Fix the pedaling plate welding set (19) to the main frame (1) with two allen bolts (18) and two flat washers (27) (fig. 4-3).
3. Fix the pedal cover (21) to the pedaling plate welding set (19) with two cross screws (23) (fig. 4-4).

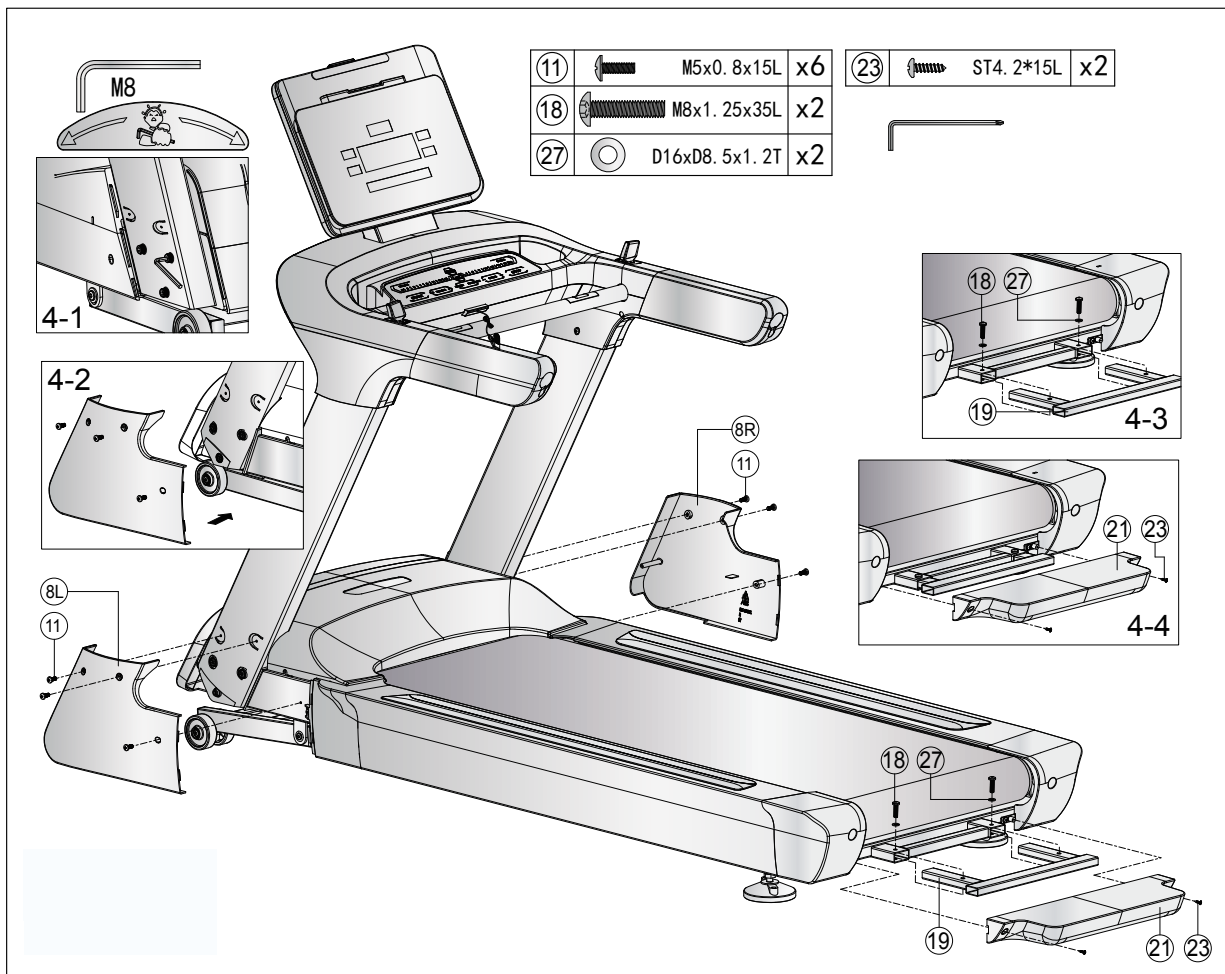

Step 5: Alignment of the feet

If the floor is uneven, you can stabilize the treadmill by turning the two setting screws under the main frame.

1. Lift the treadmill on the desired side and rotate the setting screws under the main frame.
2. Rotate the screws clockwise in order to remove them and to raise the running surface.
3. Rotate them counterclockwise in order to lower the running surface.

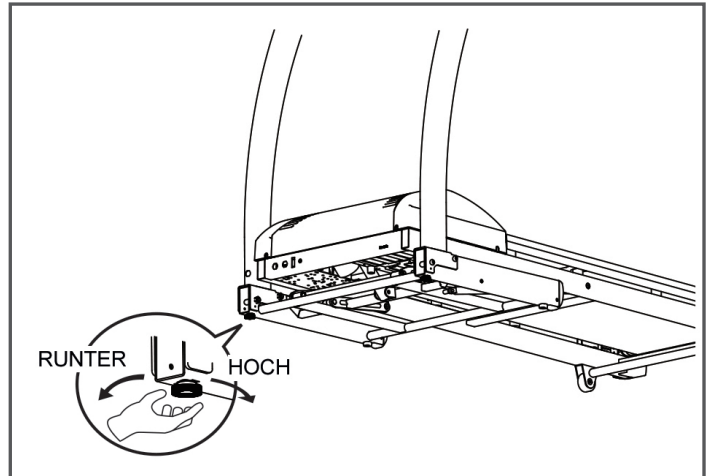

Step 6: Connecting the equipment to the mains supply

► ATTENTION

The equipment must not be connected to a multiple socket, otherwise it cannot be guaranteed that the equipment will be supplied with sufficient power. Technical errors can result.

Plug the power plug into a wall outlet that complies with the instructions in the chapter on electrical safety.

Step 7: Using the holder for mobile devices

1. Place your mobile device onto the holder (C) above the console (84).
2. Pull out the fixing hook (A) that is located on the back of the console cover and fix it at the top of your device.

ⓘ NOTICE

The scope of delivery contains a buffer strap. This can optional be stuck between your device and the console cover if there is knocking sound during workout. The buffer strap has to be stuck onto the top of the console cover.

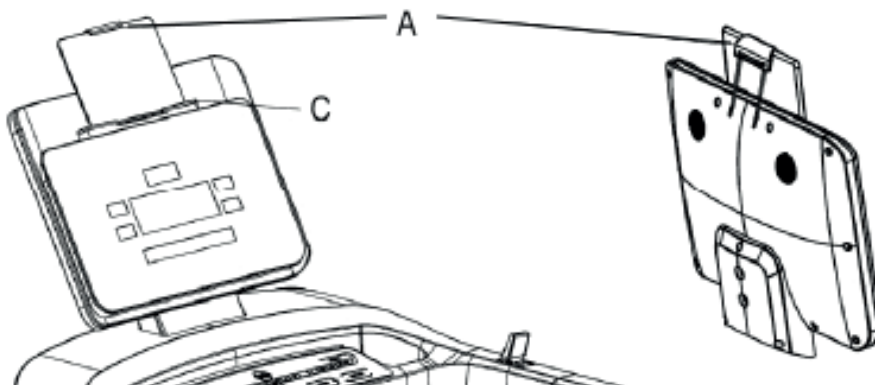

3 OPERATING INSTRUCTIONS

① NOTICE

Familiarise yourself with all the functions and setting options of the device before starting training. Have the proper use of this product explained to you by a specialist.

SAFETY KEY

⚠ WARNING

- + For your safety, the device is equipped with an EMERGENCY STOP function. The equipment can only be operated if the safety key is correctly attached to the contact point of the cockpit. If the safety key is no longer on the contact point, the equipment automatically stops. Therefore, the Safety Key cord with the clip must be attached to your clothing before every training session. If you want to quickly stop the treadmill, if you can no longer control the speed, or if another emergency occurs, remove the safety key from the cockpit using the cord.
- + To enable the safety key to detach from the contact point of the cockpit in the event of a fall, the safety key clip must be firmly attached to your clothing!
- + Make sure that the safety key is not accessible to children.

3.1 Console display

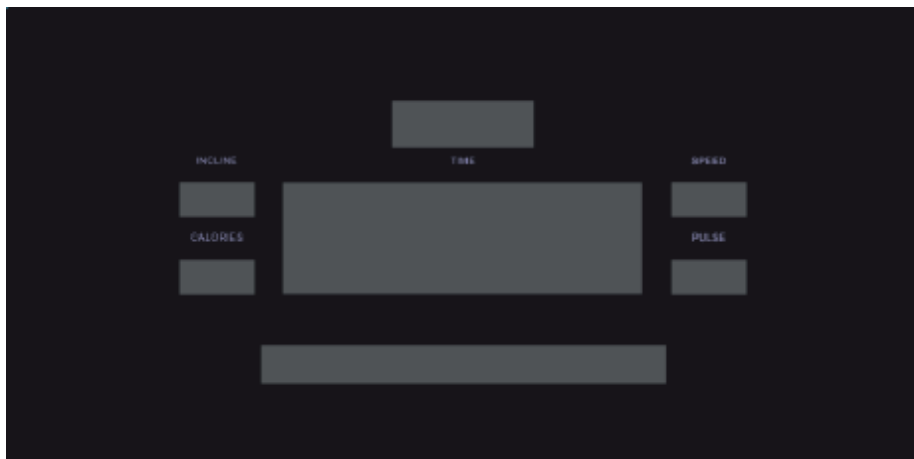

INCLINE	Indicates the current incline level between 1 - 15 %.
DISTANCE	Indicates the covered distance between 0.0 - 9999 km.
TIME	Indicates the already elapsed or remaining training time between 00:00 – 99:59 minutes.
PULSE	Indicates your current heart rate between 40 - 220 bpm.
CALORIES	Indicates the burnt calories between 0 – 999 Kcal.
HR	Indicates the current heart rate accounts in dependence of the target heart rate percentage.
SPEED	Indicates the current speed between 0.5 - 25 km/h.

3.2 Button functions

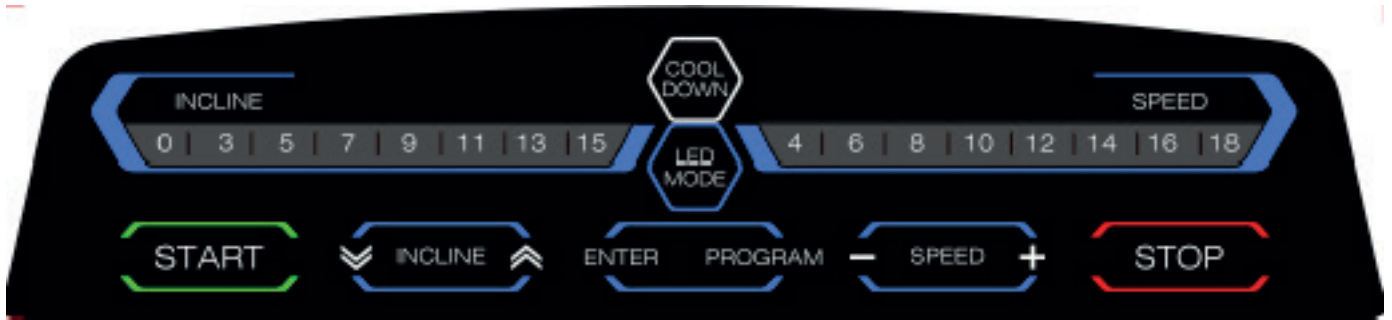

START	With this button you can start a training programme. When you are in the main menu, you can start your training via quick start. When your training is paused, you can continue with your training by pressing this button.
STOP	With this button you can pause or end your training and return to the main menu.
SPEED	With these buttons you can adjust the speed. You can adjust the speed in four ways: <ol style="list-style-type: none"> 1. The eight quick keys on the console (18/16/14/12/10/8/6/4). For example, when you press on the 12 the treadmill will adjust the speed to exact 12 km/h. 2. The buttons on the console (+ and -) 3. The switch on the right handrail. <p>ⓘ NOTICE If you tap on the little icon between the buttons on the touch screen, you will be able to type in your desired speed.</p>
INCLINE	With these buttons you can adjust the incline. You can adjust the incline in three ways: <ol style="list-style-type: none"> 1. The eight quick keys on the console (15/13/11/9/7/5/3/0). When you press on the 11 the treadmill will adjust the incline to exact 11%. 2. The arrow buttons on the console. 3. The switch on the left handrail. <p>ⓘ NOTICE If you tap on the little icon between the buttons on the touch screen, you will be able to type in your desired incline.</p>
COOL DOWN	With this button you can start the cool down phase at any time. Speed and incline will be reduced until the treadmill has come to a stop and has returned to its original position.
ENTER	With this button you confirm your entries.

LED MODE	<p>With this button you enter the LED settings.</p> <p>Running Mode: In this mode, the LED lights glow in different colours depending on the speed level: 0-6 KPH - Yellow, 6.1-12 KPH - Green, >12 KPH - Red</p> <p>Neutral Mode: In this mode, the LED lights glow in a neutral white colour.</p> <p>Multi Color Mode: Here you can choose the colour yourself. Use the SPEED and INCLINE buttons and confirm your choice with the ENTER button. You can choose between the following colours: red, blue, green, orange, pink or purple.</p> <p>OFF: Switch off the LED lights.</p>
PROGRAM	In the main menu, this button will take you directly to the pre-set programmes.

3.3 Fitness programmes

In the main menu you can choose from many different programmes. This includes a manual programme, pre-set programmes, heart rate-oriented programmes, a training programme and a body fat test.

3.3.1 Quick Start

When you are in the main menu, press the START button to start a training session via quick start. Alternatively you can also press the SPEED- or INCLINE buttons or use the switches on the handrails to select the quick start programme manually. Press the ENTER button to confirm.

3.3.2 Manual programme

1. When you are in the main menu, use the SPEED- or INCLINE buttons or the switches on the handrails to select the manual programme (MANUAL). Confirm with the ENTER button.
2. Use the SPEED- or INCLINE buttons or the switches on the handrails to set your desired training time, distance or calories. Press the ENTER button to confirm.

Speed and incline can be adjusted manually during your training.

3. Press the START button to start the programme.
4. Press the STOP button to pause your training.

The speed will be reduced slowly until the treadmill comes to a stop. In case an incline level has been set, the treadmill will remain in that position.

- 4.1. Press the STOP button again to end your training. Press the STOP button one more time to return to the main menu.
- 4.2. Press the START button to continue with your training.

→ Upon completion of the programme the console will start the cool down phase automatically.

3.3.3 Low speed programme

1. When you are in the main menu, use the SPEED- or INCLINE buttons or the switches on the handrails to select the manual programme (LOW SPEED). Confirm with the ENTER button.
2. Use the SPEED- or INCLINE buttons or the switches on the handrails to set your desired training time, distance or calories. Press the ENTER button to confirm.

Speed and incline can be adjusted manually during your training.

3. Press the START button to start the programme.
4. Press the STOP button to pause your training.

The speed will be reduced slowly until the treadmill comes to a stop. In case an incline level has been set, the treadmill will remain in that position.

- 4.1. Press the STOP button again to end your training. Press the STOP button one more time to return to the main menu.
- 4.2. Press the START button to continue with your training.

→ Upon completion of the programme the console will start the cool down phase automatically.

3.3.4 Pre-set programmes

1. When you are in the main menu, use the SPEED- or INCLINE buttons or the switches on the handrails to select the pre-set programmes (PROGRAM). Confirm with the ENTER button.
2. Use the SPEED- or INCLINE buttons or the switches on the handrails to set your desired training time, distance or calories. Press the ENTER button to confirm.
3. Use the SPEED- or INCLINE buttons or the switches on the handrails to choose one of the pre-set programme. Confirm with the ENTER button.
4. Press the START button to start the programme.

The speed and the incline can be adjusted manually during your training. But only in the respective segment.

5. Press the STOP button to pause your training.

The speed will be reduced slowly until the treadmill comes to a stop. In case an incline level has been set, the treadmill will remain in that position.

- 5.1. Press the STOP button again to end your training. Press the STOP button one more time to return to the main menu.

- 5.2. Press the START button to continue with your training.

→ *Upon completion of the programme the console will start the cool down phase automatically.*

Program		Setting time / 16 = period in each section															
		1	2	3	4	5	6	7	8	9	10	11	12	13	14	15	16
P1	SPD	2	2	4	4	3	3	4	3	5	4	2	2	5	5	3	3
	INC	1	1	2	2	3	3	3	1	2	2	3	3	2	2	2	2
P2	SPD	2	2	5	5	4	4	6	4	6	4	2	2	4	4	2	2
	INC	1	1	2	2	3	3	3	2	2	3	4	4	2	2	2	2
P3	SPD	2	2	5	5	4	4	5	4	5	4	2	2	3	3	2	2
	INC	1	1	2	2	2	2	3	1	2	2	2	2	2	2	1	1
P4	SPD	3	3	6	6	7	7	5	8	5	9	6	6	4	4	3	3
	INC	2	2	2	2	3	3	3	2	2	4	6	6	2	2	2	2
P5	SPD	3	3	6	6	7	7	5	8	6	7	6	6	4	4	3	3
	INC	1	1	2	2	4	4	3	2	2	4	5	5	2	2	1	1
P6	SPD	2	2	8	8	6	6	4	5	9	7	5	5	4	4	3	3
	INC	2	2	2	2	6	6	2	3	4	2	2	2	2	2	1	1

P7	SPD	2	2	6	6	7	7	4	4	7	4	2	2	4	4	2	2
	INC	4	4	5	5	6	6	6	9	9	10	12	12	6	6	3	3
P8	SPD	2	2	4	4	6	6	8	7	8	6	2	2	3	3	2	2
	INC	3	3	5	5	4	4	4	3	4	4	3	3	3	3	2	2
P9	SPD	2	2	4	4	5	5	5	6	5	6	3	3	3	3	2	2
	INC	3	3	5	5	3	3	4	2	3	4	2	2	3	3	2	2
P10	SPD	2	2	3	3	5	5	3	3	5	3	6	6	3	3	3	3
	INC	4	4	4	4	3	3	6	7	8	8	6	6	3	3	3	3
P11	SPD	3	3	5	5	8	8	8	9	5	7	6	6	3	3	2	2
	INC	4	4	5	5	6	6	6	9	9	10	12	12	6	6	3	3
P12	SPD	2	2	5	5	5	5	4	4	6	4	2	2	3	3	4	4
	INC	3	3	5	5	6	6	7	12	9	11	11	11	6	6	3	3
P13	SPD	4	4	2	2	6	6	8	6	3	2	6	6	2	2	2	2
	INC	3	3	4	4	6	6	2	3	7	9	5	5	2	2	2	2
P14	SPD	3	3	4	4	4	4	3	5	5	6	3	3	3	3	2	2
	INC	3	3	5	5	4	4	4	3	4	3	2	2	2	2	4	4
P15	SPD	4	4	2	2	4	4	6	8	7	8	6	6	2	2	3	3
	INC	4	4	3	3	4	4	4	3	4	2	3	3	2	2	5	5
P16	SPD	3	3	2	2	5	5	7	3	5	6	7	7	2	2	1	1
	INC	7	7	12	12	9	9	11	11	4	3	3	3	2	2	4	4
P17	SPD	5	5	10	10	8	8	10	8	12	10	5	5	12	12	8	8
	INC	1	1	4	4	6	6	6	1	4	4	6	6	4	4	4	4
P18	SPD	5	5	12	12	10	10	12	10	12	10	10	10	10	10	5	5
	INC	1	1	4	4	4	4	6	1	4	4	6	6	8	8	4	4
P19	SPD	3	3	7	7	5	5	7	6	10	7	3	3	10	10	5	5
	INC	1	1	2	2	4	4	5	1	2	2	4	4	3	3	3	3
P20	SPD	3	3	10	10	7	7	12	7	12	7	7	7	7	7	3	3
	INC	1	1	2	2	4	4	5	2	2	4	6	6	3	3	2	2

3.3.5 User-defined programmes

1. When you are in the main menu, use the SPEED- or INCLINE buttons or the switches on the handrails to select the user-defined programmes (USER). Confirm with the ENTER button.
2. Use the SPEED- or INCLINE buttons or the switches on the handrails to choose one of the four user profiles (U1-U4). Confirm with the ENTER button.
3. Enter your gender, age, weight and the desired training time with the SPEED- or INCLINE buttons or the switches on the handrails. Confirm all your entries with the ENTER button.
4. Now set the speed for all the individual segments with the SPEED buttons or the switch on the right handrail and confirm each entry with the ENTER button. Continue until you have set a speed value for all the segments.
5. Now set the incline for all the individual segments with the INCLINE buttons or the switch on the left handrail and confirm each entry with the ENTER button. Continue until you have set an incline value for all the segments.
6. Press the START button to start the programme.

Speed and incline can be adjusted again during your training. But only in the respective segment.

7. Press the STOP button to pause your training.

The speed will be reduced slowly until the treadmill comes to a stop. In case an incline level has been set, the treadmill will remain in that position.

- 7.1. Press the STOP button again to end your training. Press the STOP button one more time to return to the main menu.
- 7.2. Press the START button to continue with your training.

→ Upon completion of the programme the console will start the cool down phase automatically.

3.3.6 Heart rate-oriented programmes

WARNING

Your training equipment is not a medical device. The heart rate measurement of this equipment may be inaccurate. Various factors can affect the accuracy of the heart rate measurement. The heart rate measurement serves only as a training aid.

There are three different heart rate-oriented programmes. Either choose one of the pre-set target heart rates (60% or 80% of your maximum heart rate) or choose „Target HR“ to set a target heart rate yourself. Your maximum heart rate is calculated depending on your age. We recommend a chest strap for these programmes.

1. When you are in the main menu, use the SPEED- or INCLINE buttons or the switches on the handrails to select the heart rate-oriented programmes (HRC). Confirm with the ENTER button.
2. Enter your gender, age, weight and the desired training time with the SPEED- or INCLINE buttons or the switches on the handrails. Confirm all your entries with the ENTER button.
3. Choose either 60%, 80% or THR.
- 3.1. If you have chosen THR you will be able to set the target value yourself (between 72-168).

Speed and incline can be adjusted again during your training.

4. Press the START button to start the programme.
5. Put your hands around the hand pulse sensors or use a chest strap.

NOTICE

In case the console does not receive a signal for 15 seconds the programme will be stopped.

6. Press the STOP button to pause your training.

The speed will be reduced slowly until the treadmill comes to a stop. In case an incline level has been set, the treadmill will remain in that position.

- 6.1. Press the STOP button again to end your training. Press the STOP button one more time to return to the main menu.
- 6.2. Press the START button to continue with your training.

→ *Upon completion of the programme the console will start the cool down phase automatically.*

3.3.7 Training programme

In this programme you are able to set a specific distance that must be covered in a fixed time.

1. When you are in the main menu, use the SPEED- or INCLINE buttons or the switches on the handrails to select the training programme (TRAINING). Confirm with the ENTER button.
2. Set the desired time with the SPEED- or INCLINE buttons or the switches on the handrails and confirm your entry with the ENTER button.
3. Set the desired distance with the SPEED- or INCLINE buttons or the switches on the handrails and confirm your entry with the ENTER button.

Speed and incline can be adjusted again during your training.

4. Press the START button to start the programme.
5. Press the STOP button to pause your training.

The speed will be reduced slowly until the treadmill comes to a stop. In case an incline level has been set, the treadmill will remain in that position.

- 5.1. Press the STOP button again to end your training. Press the STOP button one more time to return to the main menu.
- 5.2. Press the START button to continue with your training.

→ *Upon completion of the programme the console will display a summary of the collected training data.*

3.4 Body fat test

1. When you are in the main menu, use the SPEED- or INCLINE buttons or the switches on the handrails to select the body fat test (FAT). Confirm with the ENTER button.
2. Put your hands around the hand pulse sensors.
3. In 10 seconds the console will calculate your body fat percentage and will display the result in form of a rating.

Possible results:

SEX	Male	Female
AGE	10-99	
HEIGHT	100-200	
WEIGHT	30-150 Kg , 40-400LB	
FAT	<19	UNDERWEIGHT
FAT	=(20-25)	NORMAL WEIGHT
FAT	=(26-29)	OVER WEIGHT
FAT	>30	OBESITY

3.5 Bluetooth and fitness apps

1. When you are in the main menu, use the SPEED- or INCLINE buttons or the switches on the handrails to select the bluetooth function. Confirm with the ENTER button.
2. Activate bluetooth and confirm with the ENTER button

NOTICE

This console is equipped with two Bluetooth interfaces. One is used to connect to fitness apps like Kinomap (IRUNNING 000X). The other one connects to the speakers of the console (AUDIO 000X). Then you can play audio files from your mobile device via the console. The treadmill can only be connected via one of the interfaces, not both at the same time.

To use training apps you will have to connect your treadmill with your mobile device (tablet or smart phone). To do this, please activate the bluetooth function on your mobile device. Now choose your treadmill.

Please take note that your mobile device needs to be compatible with the bluetooth interface of the treadmill (bluetooth 4.0). Now start the fitness app. It might happen that you need to connect both the app and the console additionally. To do this, please follow the instructions given in the app. The console will be switched off as soon as the treadmill is connected with the app. When the connection is cut, the console will turn on again.

You will find the fitness apps in the app stores of Google or Apple. There you will find the apps „Kinomap“ or „Zwift“. Please note that these apps are produced by an external manufacturer. Sport-Tiedje does not take any responsibility regarding the availability, functionality or contents of these programmes.

IMPORTANT NOTE

To make sure the pre-installed apps are working correctly, they must be updated regularly. If needed, the respective app will notify you to do so. To update the app, you need a google account. A google email is sufficient. Just follow the instructions on the screen to perform the update.

Please note: The system is set up only for the pre-installed apps. Do not install any additional apps as their proper functionality can not be guaranteed. The installation of other apps might cause technical issues.

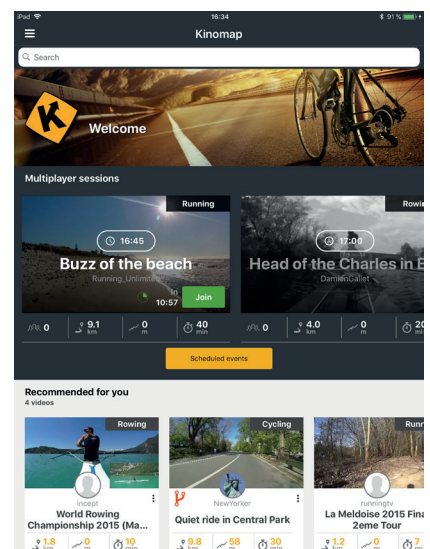
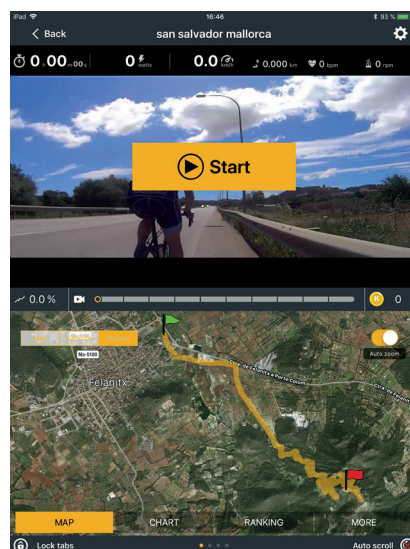
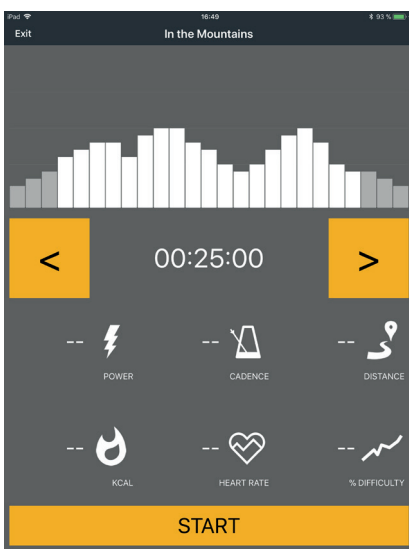

Example: Kinomap

4.1 General Instructions



WARNING

- + The storage location should be chosen so that improper use by third parties or children can be prevented.
- + If your equipment does not have transportation wheels, the equipment must be disassembled before transportation.

▶ ATTENTION

- + Make sure that the equipment is protected from moisture, dust and dirt in the selected storage location. The storage location should be dry and well ventilated and have a constant ambient temperature between 10°C and 35°C.

4.2 Transportation Wheels

▶ ATTENTION

If you want to transport your equipment over particularly sensitive and soft floor coverings, such as parquet, planks or laminate, lay out the transport route with cardboard or similar to avoid possible floor damage.

1. Stand behind the equipment and lift it until the weight is transferred to the transportation wheels. After that, you easily can move the equipment to a new position. For long transport distances the equipment should be disassembled and safely packed.
2. Select the new location by following the instructions in the section 1.4 of this manual.

5.1 General Instructions



WARNING

- + Do not make any improper changes to the equipment.



CAUTION

- + Damaged or worn components may affect your safety and the life of the equipment. Therefore, immediately replace damaged or worn components. In such a case, contact the contract partner. The equipment must not be used until it has been repaired. If necessary, use only original spare parts.

► ATTENTION

- + In addition to the instructions and recommendations for maintenance and care given here, additional service and/or repair work may be necessary; this must only be carried out by authorised service technicians.

5.2 Faults and Fault Diagnosis

The equipment undergoes regular quality controls during production. Nevertheless, faults or malfunctions may occur. Frequently, individual parts are responsible for these disturbances, an exchange is usually sufficient. Please refer to the following overview for the most common errors and how to correct them. If the equipment still does not function properly, contact your contract partner.

Fault	Cause	Solution
Console is not responding	Safety key missing or not inserted correctly	Check whether Safety Key is inserted and insert if necessary
Running mat slanting	Running mat not centered	Adjust the running mat according to the instructions
Grinding noises		
Running mat slips through/stops	Tape tension/lubrication not correct	Check belt tension/lubrication according to instructions
Display is blank/is not working	+ Interrupted power connection + Loose cable connections	+ Power switch to on + Check whether Safety Key is plugged in + Check cable connections
No pulse display	+ Sources of interference in the room + unsuitable chest strap + Wrong position of chest strap + Chest strap defective or battery empty + Pulse display defective	+ Eliminate sources of interference (e.g. mobile phone, WLAN, lawn mower and vacuum cleaner robot, etc. ...) + Use a suitable chest strap (see RECOMMENDED ACCESSORIES). + Reposition chest strap and/or moisten electrodes + Changing batteries + Check if pulse display by hand pulse possible

5.3 Care and Maintenance

The most important maintenance measure is the care of the running mat. This includes adjustment, re tensioning and lubrication of the running mat. Damage resulting from insufficient or neglected care is not covered by the warranty. You should therefore carry out maintenance checks at regular intervals. Be very careful when adjusting and tightening the running mat, as a strong over voltage or under voltage can cause damage to the equipment. The running mat is adjusted at the factory according to the regulations before delivery. However, it may happen that the running mat slips during transport.

5.3.1 Adjusting the Running Mat

During training, the running mat should run as centrally and straight as possible. The alignment of the running mat can change depending on the stress and load. Another reason can be the positioning of the equipment on an uneven surface.

 **CAUTION**

During the following maintenance nobody must be on the treadmill!

1. Let the treadmill run at a speed of 5 km/h.
2. If the running mat deviates to the left, turn the left adjusting screw at the rear end of the device max. one $\frac{1}{4}$ turn clockwise and the right adjusting screw max. one $\frac{1}{4}$ turn anticlockwise.
3. If the running mat deviates to the right, turn the right adjusting screw at the rear end of the device max. $\frac{1}{4}$ turn clockwise and the left adjusting screw max. $\frac{1}{4}$ turn anticlockwise.
4. Then observe the mat for about 30 seconds, as the change is not immediately visible.
5. Repeat this procedure until the running mat is straight again. If the running mat cannot be adjusted, please contact your contract partner.

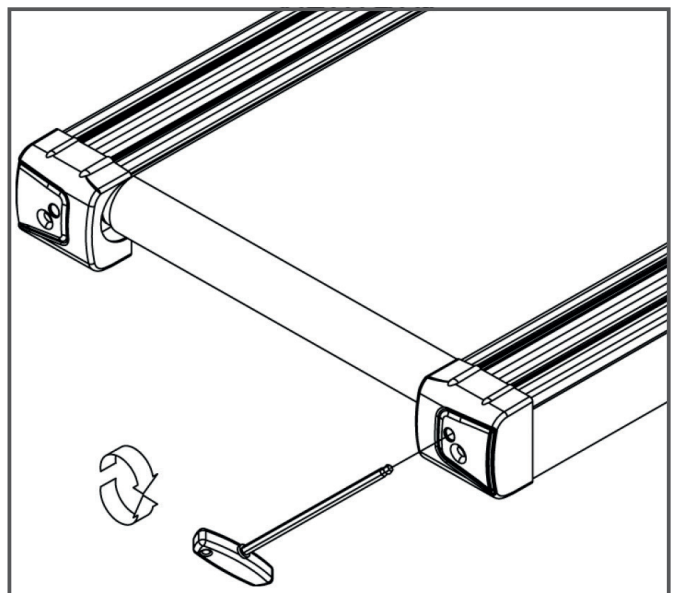

5.3.2 Re-tensioning the Running Mat

If the running mat slips over the rollers during operation (if this is the case, there is a noticeable jerk during running), the running mat must be re tightened.

In most cases, the slipping is caused by stretching of the mat through use. This is perfectly normal.

ⓘ NOTICE

Re-tensioning is carried out using the same adjusting screws that are used for adjustment.

1. Let the treadmill run at a speed of 5km/h.
2. Turn the left and right adjusting screws directly one after the other, max. one ¼ turn clockwise.
3. Then check whether the running mat continues to slip. If this is the case, you must perform the described procedure again.

5.3.3 Lubricating the Running Mat

If the running mat is not sufficiently lubricated, friction increases significantly and this leads to heavy wear of the endless belt, running plate, motor and circuit board. If you feel an increased friction of the running mat, this is an indication that you should lubricate the mat. However, lubrication should be carried out at least every 3 months or every 50 operating hours. Whichever case comes first.

ⓘ NOTICE

If your treadmill is equipped with a folding mechanism, you can also lubricate it when it is folded.

1. Raise the running mat slightly.
2. Apply some silicone oil or silicone spray to the entire deck and distribute evenly.
3. Continue turning the belt by hand so that the entire surface between the endless belt and the running plate is lubricated.
4. Wipe off the excess silicone oil or silicone spray.

ⓘ NOTICE

This maintenance must also be carried out after prolonged non-use of the equipment.

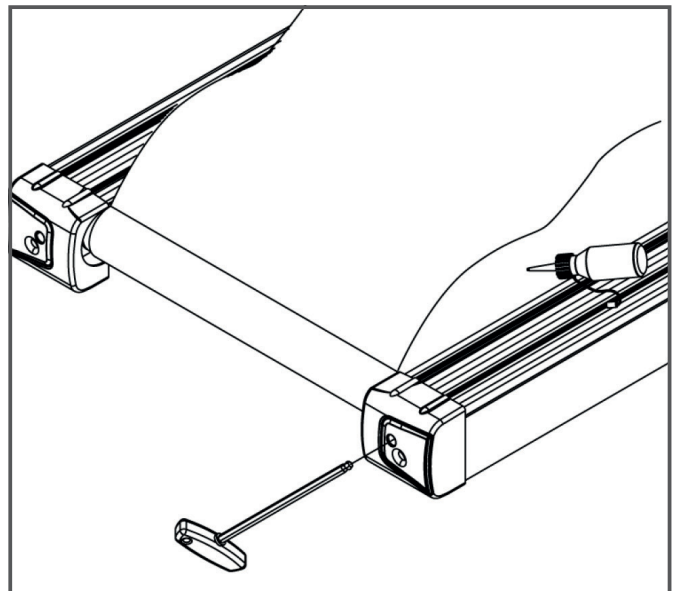

5.4 Maintenance and Inspection Calendar

To avoid damage from body sweat, the equipment must be cleaned with a damp towel (no solvents!) after each training session.

The following routine tasks must be performed at the specified intervals:

Part	Weekly	Monthly	Quarterly
Display console	C	I	
Tension of the running mat			I
Lubrication of the running mat			I
Plastic covers	C	I	
Screws and cable connections			I
Legend: C = clean; I = inspect			

6 DISPOSAL

At the end of its operational life, this equipment cannot be disposed of in normal household waste. Instead, it must be disposed of via an electricals recycling centre. Further information can be obtained from your local authority's recycling service.



The materials can be recycled as per their symbols. Through the reuse, recycling of materials or other forms of recovery of old equipment, you make an important contribution to the protection of the environment.

7 RECOMMENDED ACCESSORIES

To make your training experience even more efficient and pleasant, we recommend that you add suiting accessories to your fitness equipment. For treadmills this could for example be a **floor mat**, which makes your fitness equipment stand more securely and also protects the floor from sweat or **silicone spray** to keep moving parts in good shape and lubricate the running mat. Furthermore, there are additional **handrails** available for some treadmills.

If you have purchased a fitness machine with pulse training and want to train your heart rate, we strongly recommend that you use a compatible **chest strap**, as this ensures optimum transmission of the heart rate.



Our range of accessories offers the highest quality and makes training even better. If you would like to find out more about compatible accessories, please go to the detail page of the product in our webshop (the easiest way is to enter the article number in the search field above) and go to the recommended accessories on this page. Alternatively, you can use the QR code provided. Of course, you can also contact our customer service: by telephone, e-mail, in one of our branches or via our social media channels. We will be happy to advise you!



floor mat



chest strap



handrails



lubricant

8.1 Serial Number and Model Name

In order to provide you with the best possible service, please have the model name, article number, serial number, exploded drawing and parts list ready. The corresponding contact options can be found in chapter 10 of this operating manual.

NOTICE

The serial number of your equipment is unique. It's located on a white sticker. The exact position of this sticker is shown in the following illustration.

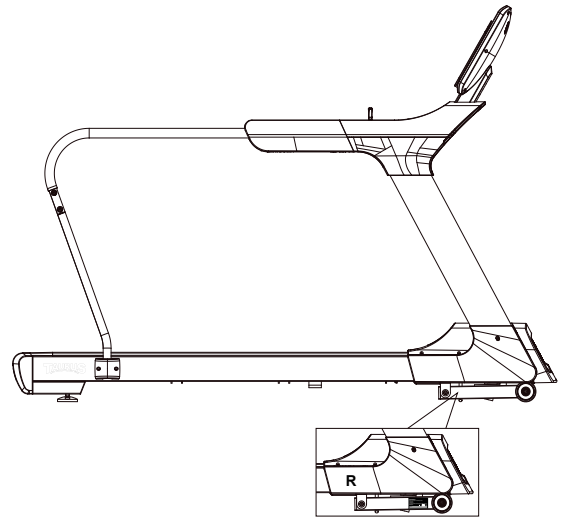

Enter the serial number in the appropriate field.

Serial number:

Brand / Category:

Model Name:

SKU:

8.2 Parts List

No.	Name	Supplier Parts No.	Specification	Qty.
1	Main frame	264C1-3-1000-B99		1
2	Left handlebar post	264C1-3-1300-B92		1
3	Right handlebar post	264C1-3-1400-B92		1
4	Handlebar set	264C1-3-1500-B93		1
5	Front handlebar set	264A1-3-1550-B90		1
6	Stabilizer	264C1-3-1600-B92		1
7	Computer supporting tube	264A1-3-2000-B91		1
8L	Lower cover for handlebar post(left)	264C1-6-1371-B0	452.5*296.2*75.7	1
8R	Lower cover for handlebar post(right)	264C1-6-1471-B0	452.5*296.2*75.7	1
9	Flat washer	55105-1-1510-DA	D15*D5.2*1.0T	4
10	Allen bolt	54010-8-0065-CU7	M10*1.5*65L,12.94	6
11	Cross bolt	52605-2-0015-F0	M5*0.8*15L	27
12	CSK inner hexagon bolt	51608-5-0035-F0	M8*1.25*35L,8.8	8
13	Wooden board	264C1-6-1073-B0	1445*695*25T	1
14	Buffer bar	264C1-6-1084-B0	25*2T*1380L	2
15	Metal clip	264C1-6-1086-J1	30*40*6	16
16	Flat washer	55104-1-1210-NA	D12*D4.3*1.0T	4
17	Running belt	264C3-6-1072-B0	600*4.3T*3500L	1
18	Allen bolt	50308-5-0035-F0	M8*1.25*35L,8.8	2
19	Pedaling plate welding set	264C1-3-1055-B90		1
20a	Pedaling plate	264C1-6-1076-B4	150*195.5*1385L	2
20b	Decorative strip for pedaling plate	264C1-6-1092-B0		2
21	Pedal cover	264C1-6-2424-B0	570.3*165.3*59	1
22	Buffer pedal pad	264C1-6-1061-B1	1197*100.7*2.7T	2
23	Cross screw	52842-2-0015-F0	ST4.2*15L	69
25	Buffer 4	26100-6-1088-F0	D30*37L*M8	2
26	Buffer 3(black)	26100-6-1083-B0	D30*37L*M8,95	2
27	Flat washer	55108-1-1612-FA	D16*D8.5*1.2T	10
28	Anti-loose nut	55208-1-2008-FA	M8*1.25*8T	6
29	Allen bolt	50308-5-0020-UFO	M8*1.25*20L,8.8	2

30	Rear roller set	264C1-3-1200-00	D25*D100*686L	1
31	Inner hex head screw	54010-8-0080-F0	M10*1.5*80L,12.9	3
32L	Rear cover(left)	264C1-6-2406-B2	186.5*214.5*195.7	1
32R	Rear cover(right)	264C1-6-2407-B2	186.5*214.5*195.7	1
33	Buffer 1(red)	26100-6-1081-R0	D30*37L*M8,45	2
34	Nylon universal adjusting feet	264C1-6-1094-B1	D122.5*M16*80L	2
35	Front roller set	264C1-3-1100-00	D25*D100*720L	1
36	Inner hex head screw	54010-5-0045-F4	M10*1.5*45L,8.8	1
37	Multi-groove belt	58004-6-1119-00	270/PJ10	1
38	Motor	261A3-6-1085-00	AC3.0HP	1
39	Anti-loose nut	55210-1-2010-CA	M10*1.5*10T	6
40	Flat washer	55110-1-2020-CA	D20*D11*2T	12
41	Inner hex head screw	54010-5-0030-C0	M10*1.5*30L,8.8	4
42	Flat washer	551E1-1-2820-NA	D28*D14*2T	4
43	Insulating sleeve	26200-6-1063-B0	D20*D10*8T	5
44	Motor buffer	26200-6-1093-B0	65*40*5T	4
45	Bolt	50106-5-0050-N0	M6*1*50L	4
46	Allen bolt	50108-5-0060-N0	M8*1.25*60L,8.8	1
47	Fixing bracket for motor cover	26100-6-1090-00	32*18*18	4
48	Cable tie base	26100-6-1089-00	15*10	2
49	Screw	50904-2-0015-N0	ST4*1.41*15L	2
50	Inner hex head screw	54006-5-0110-F5	M6*1.0*110L,8.8	10
51	Upper motor cover	264C1-6-2401-B0	800*454.8*129.5	1
52	Al plate with logo on motor cover	264C2-6-2404-B0		1
53	Socket	26100-6-2413-00		1
54	Cross screw	53329-2-0009-D0	ST2.9x9.5L	31
55	Power supplier board	26100-6-2414-B0	130*45*6T	1
56	Switching mode power supplier	261D8-6-2411-00		1
57	Buffer	55308-4-0020-G9	D10.5*20L	4
58	Overcurrent protector	261D1-6-2412-00	15A	1
59	Flat washer	55105-1-1208-DA	D12*D5.2*0.8T	2
60	Anti-loose nut	55205-1-2005-DA	M5*0.8*5T	2
61	Lower motor cover	264A1-6-2402-B0	812.5*237.2*180.6	1

62	Inner hex head screw	54010-8-0045-F4	M10*1.5*45L,12.9	4
62A	Inner hex head screw	54010-8-0050-C4	M10*1.5*50L,12.9	1
63	Plastic flat washer	55110-1-2404-BF	D10*D24*0.4T	4
64	Incline	26200-6-1975-02	JS19-B	1
65	Inner hex head screw	54010-8-0065-C4	M10*1.5*65L,12.9	1
66	Moving wheel	26200-6-1087-B0	D82*35L	4
67	Allen bolt	50308-5-0020-UF0	M8*1.25*20L,8.8	8
68	Flat washer	55108-1-2115-FA	D21*D8.5*1.5T	4
69	Cap	55310-2-2550-B8	25*50*14,2.0	4
70	Short axle	26200-6-1673-N0	D18.7*41L	2
71	Nylon washer	55121-1-3730-0F	D21*D37*3T	4
72	Flat washer	55108-1-2520-FA	D25xD8.5x2T	4
73	Buffer	55308-2-0010-B3	D26*10*M8*1.25	2
74	Upper fixing plate for handle pulse	737L6-6-2491-B0	40*15.2,LOGO	2
75	Allen bolt	50308-5-0055-F3	M8*1.25*55L	1
76	Allen bolt	50308-5-0050-F3	M8*1.25*50L	1
77	Handle pulse	737L6-6-2478-00	100.3*29.5*0.4T	4
78	Lower fixing plate for handle pulse	737L6-6-2492-B0	40*15.2	2
79	Screw	50904-2-0015-F0	ST4x1.41x15L	2
80	Handle grip	26200-6-1584-B0	D30*3T*710L	1
81	Cross bolt	52605-2-0010-N0	M5*0.8*10L	4
82	Lower computer cover	264A1-6-1703-B2	518*395*69.8	1
83	Upper computer cover	264A1-6-1711-B0	517.8*395*35	1
84	Computer	264C4-6-1701-B0	AB00324	1
85L	Left trigger	26200-6-1598-B0	53.3*46.9*14.7	1
85R	Right trigger	26200-6-1599-B0	53.3*46.9*14.7	1
86L	Sticker under left trigger	26200-6-1583-00	66.9*25.4	1
86R	Sticker under right trigger	26200-6-1593-00	66.9*25.4	1
87	Cross screw	52804-2-0012-F0	ST4*1.41*12L	10
88	Trigger base	26200-6-1579-01		2
89L	Connect cover L	264C1-6-1377-B0	191.8*195.6*181	1
89R	Connect cover R	264C1-6-1477-B0	191.8*195.6*181	1

90	Lower cable of trigger	264D2-6-1582-01	900L-3P-+PC250 2464 20#	2
91	Pin	71600-6-4586-60	D6*26.5*7.7	2
92	Inner hex head screw	54006-5-0015-F0	M6*1*15L,8.8	4
93	Handle pulse cable	261D8-6-1785-00	1000L,2pin+pc110*2	2
94	Buffer 2(blue)	26100-6-1082-K0	D30*37L*M8,75	2
95	Emergency stop pin	26100-6-1731-C1	21*18*1.5T	1
96	Safety key	26200-6-1732-R0	78.6*35*18.2	1
97	Safety clip	26200-6-1793-R0	830L	1
98	Cable for emergency stop function	261D8-6-1736-00	450L	1
99	Strengthen tube for rear cover	264C1-6-1052-J1	20*40*2.0T*104	4
100	Inner case of safety key	26100-6-1734-B0	39*15*13.3	2
101	Fixing plate for computer	264A1-3-1530-J1		1
102	Safety key base	26200-6-1733-B0	74*45*7	1
103	Upper cover for handling tube	264A1-6-1576-B0	836*583*159.3	1
104	Lower cover for handling tube	264A1-6-1577-B0	836*356.8*193.7	1
105L	Side cover for handling tube(left)	264C1-6-1594-B0	416.3*46*153.3	1
105R	Side cover for handling tube(right)	264C1-6-1595-B0	416.3*46*153.3	1
106A	Back cover for computer	264A1-6-1748-B0	207.3*188*65.5	1
106B	Decorative cover for computer	264A1-6-1749-B0	188*49.2*20.5	1
107L	Left handlebar grips	264A1-6-1571-B0	448.7*126*71	1
107R	Right handlebar grips	264A1-6-1572-B0	448.7*126*71	1
108	Hollow cap	264A1-6-2010-B0	40x80x119	1
109	Flat washer	55105-1-1510-DA	D15*D5.2*1.0T	24
110	Grounding cable(1_x000D_)	26100-6-1787-04	350L	1
111	Grounding cable(2_x000D_)	264D2-6-1788-00	300L	1
112	Live wire(1)	261A2-6-1789-00	450L	1
113	Live wire(2)	26100-6-1790-01	60L	2
114	Neutral wire (1)	26100-6-1791-00	100L	1
115	Neutral wire (2)	26200-6-1792-00	220L	1
116	Magnet ring	26100-6-1079-00	D31*16	1
117	Motor decorative cover	264C1-6-2403-Aa0	702*40.8*50.1	1

118	Upper cable of trigger	261D8-6-1589-02	550L,7pin+7pin	1
119L	Inside cover for handrail (left)	264C1-6-1596-B0	416.3*42*153.3	1
119R	Inside cover for handrail (right)	264C1-6-1597-B0	416.3*42*153.3	1
120	Upper computer cable	264A1-6-1771-00	8P+850L	1
121	Middle computer cable	26200-6-1772-01	8P+1000L	1
122	Lower computer cable	26200-6-1773-00	8P+(6/2)PIN500L	1
123	Button plate	264A1-6-1756-B0	468*105.4*13.3	1
124	Filter	261D1-6-1067-00	15A	1
125	Coil	261A2-6-1066-00	15A	1
126	Electric cable	264C1-6-1775-00	1700L	1
127	Overlay	264A1-6-1706-B0	491*296*20	1
129	Allen cross spanner	58030-6-1051-N0	M6*130L 8.8	1
130	Allen spanner	58030-6-1052-N0	M8*120L 8.8	1
131	Speaker cover	264A1-6-1762-B0		2
132	USB module	264D3-6-1723-00	PA-AB00321-K1	1
133	CSK cross self-tapping screw	51004-2-0010-N0	ST4*1.41*10L	4
134	Cross round-head self-tapping screw	54723-2-0008-C0	ST2.3*8L	24
135	Button PCB board	264A1-6-1759-00		1
136	Allen bolt	50308-5-0060-F3	M8*1.25*60L	1
137	Inverter	262A3-6-1783-00	RM6T6-2003E1	1
138	Neutral wire(1)	261A2-6-1791-00	450L	1
139	Pad of tablet support	264A1-6-1777-B0	409*15*2T	1
140	Cross tube of computer supporting tube	261D8-6-2001-B20	10*20*1.5T*320L	1
141	Cross bolt	52606-2-0015-F0	M6*1*15L	4
142	Allen bolt	50308-5-0015-F0	M8*1.25*15L,8.8	4
143	Spring Washer	55108-2-1520-FA	D15.4xD8.2x2T	4
144L	Left speaker	261D8-6-1722-01	B00202050,4Ω 3W,300L	1
144R	Right speaker	261D8-6-1761-01	B00202052,4Ω 3W,400L	1
146L	Left cap	264A1-6-1077-B0	D40.7*51.1	1
146R	Right cap	264A1-6-1078-B0	D40.7*51.1	1
147L	Left pad of bottle	264A1-6-1754-B0	106.5*89.2*3T	1
147R	Right pad of bottle	264A1-6-1755-B0	106.5*89.2*3T	1

148	Wireless pulse receiver	261D8-6-1786-00	JW-WS809	1
150	Hex nut	55208-2-2006-NA	M8*1.25*6T	1
151	Spacer ring	73800-6-3892-N0	D11.5*D8*3.5T	2
152	adjust round wheel	26200-6-1095-B0	D27*10L	2
153	Ground line(1	26200-6-1787-00	330L	1
156	Upper cable of LED light	264A1-6-1739-00	4P+-800	1
157	Middle cable of LED light	26200-6-1740-01	4P+-1100	1
158	Lower cable of LED light	26200-6-1741-00	4P+-600	1
159	LED light strap connecting plate	261D1-6-1744-00	PA-AA01170-K5	1
160	PC spacer column	261D1-6-1782-00	D5*D3.5*19.2	4
161	Light strap cable(1)	261D1-6-1742-00	4P+-1000	2
162	Light strap	261D1-6-1737-00	LED7 135CM	2
163	Bolt	50805-2-0010-N0	M5x0.8x10L	4
165	Metal clip (3)	264C1-6-1054-B91	25*25*40	2
168	Elastic rope	264A1-6-2098-B1	D2.5*500L	1
169	Fixing hook	26502-6-2097-B0	37.8*100*20.6	1
170	Pad holder	26500-6-1713-B0	271.8*25*20	1
171	Pad holder support	26500-6-1766-B0	271.9*29.8*20.1	1
172	Cross screw	53335-2-0013-N0	ST3.5*13L	3
173	Buffer bar	264A1-6-1084-B0	255*10*2T	1

8.3 Parts List (Optional Hand Rails)

No.	Name	Supplier Parts No.	Specification	Qty.
1L	Left extended handrail	26403-6-1511-B90	D31.8*1.8T*903L	1
1R	Right extended handrail	26403-6-1521-B90	D31.8*1.8T*903L	1
2	Handrail support tube	26403-3-1550-B90	KW5124-1	2
3	Inner hex screw	54008-5-0055-F4	M8*1.25*55L	4
4	Foam	58015-6-1424-B0	D30*3T*860L	2
5	Flat end fastening hex screw	54108-2-0025-F0	M8*1.25*25L	4
6	Inner hex bolt	54010-5-0100-F6	M10*1.5*100L	2
10	Inner hex spanner(M4)	58030-6-1047-D0	M4*68L*13	1

8.4 Exploded Drawing

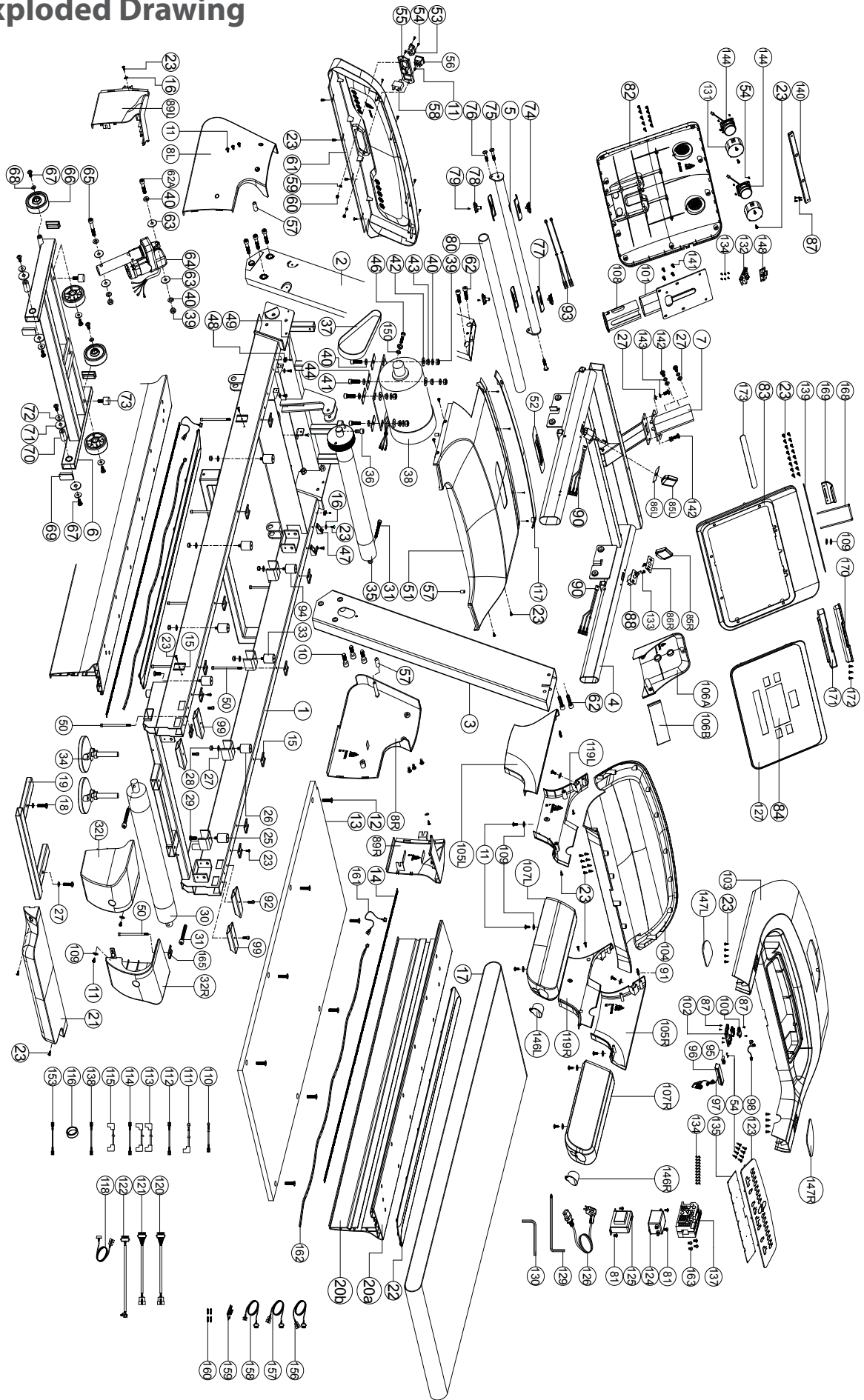

8.5 Exploded Drawing (Optional Hand Rails)

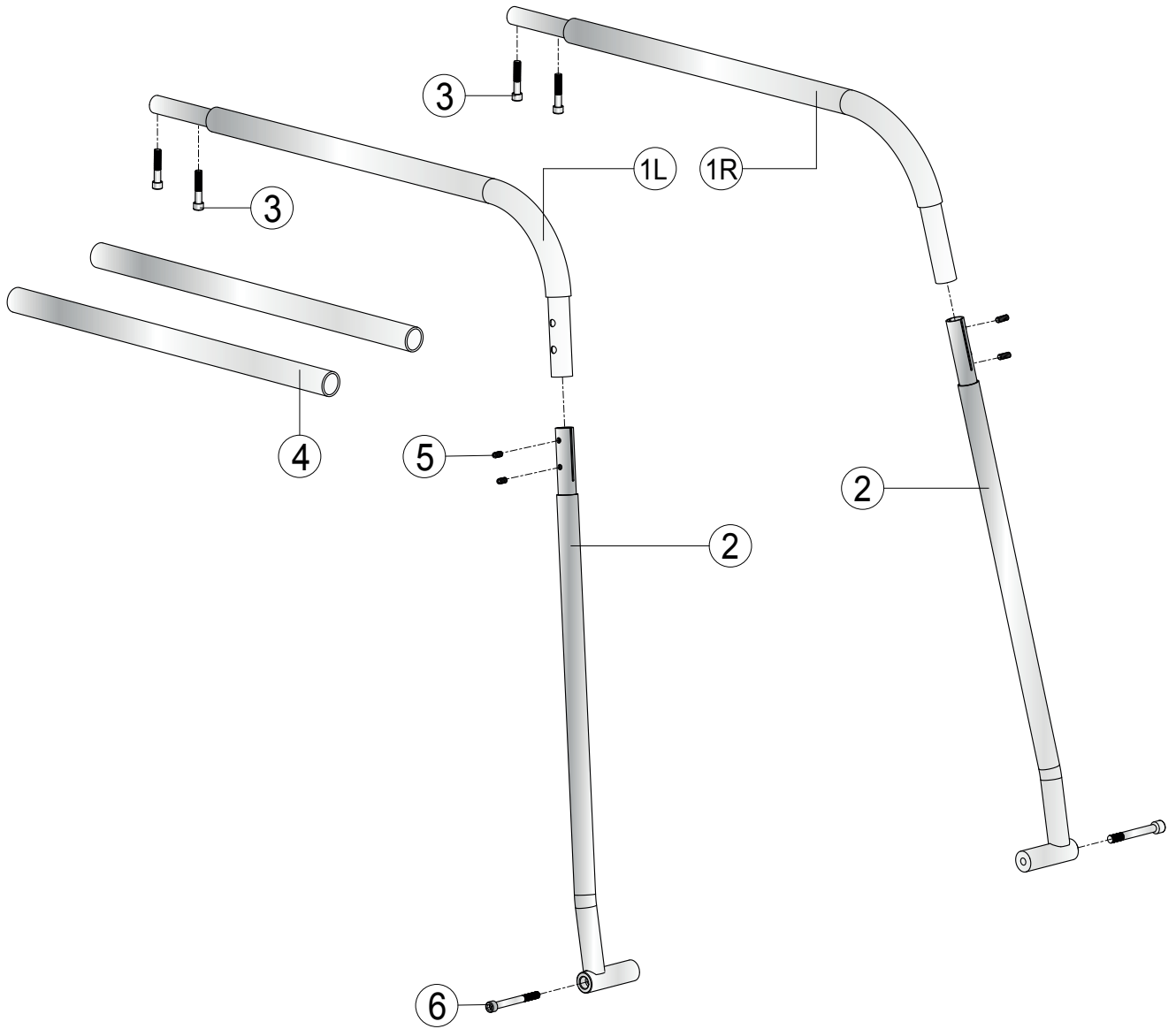

Training equipment from Taurus® is subject to strict quality control. However, if a fitness equipment purchased from us does not work perfectly, we take it very seriously and ask you to contact our customer service as indicated. We are happy to help you by phone via our service hotline.

Error Descriptions

Your fitness equipment is developed for long-term, high-quality training. However, should a problem arise, please first read the operating instructions. For further assistance, please contact your contract partner or call our service hotline. To ensure your problem is solved as quickly as possible, please describe the defect as exactly as possible.

In addition to the statutory warranty, we provide a warranty for every fitness equipment purchased from us according to the following provisions.

Your statutory rights are not affected.

Warranty

The warranty is the first/original buyer.

Warranty periods

The following warranty periods begin on delivery of the fitness equipment.

Warranty period

The warranty periods, shown on our web shop, begin on delivery of the fitness equipment. The respective warranty periods for your equipment can be found on its product website.

Repair Costs

According to our choice, there will either be a repair, a replacement of individual damaged parts or a complete replacement. Spare parts, that have to be mounted while assembling the equipment, have to be replaced by the warranty holder personally and are not a part of repair. After the expiration of the warranty period, the responsibility for parts costs, repair costs, installation costs and delivery costs lies with the warranty holder.

The terms of use are defined as follows:

- + Home use: solely for private use in private households up to 3 hours per day
- + Semi-professional use: up to 6 hours per day (e. g. rehabilitation centres, hotels, clubs, company gyms)
- + Professional use: more than 6 hours per day (e. g. commercial gyms)

Warranty Service

Within the warranty period, equipment which develops faults as a result of material or manufacturing defects, will be repaired or replaced at our discretion. Ownership of equipment or parts of equipment which have been replaced is transferred to us. The warranty period is not extended nor does a new warranty period begin following repair or replacement under the warranty.

Warranty Conditions

For the warranty to be valid, the following steps must be taken:

Please contact our customer service by email or phone. If the product under warranty has to be sent in for repair, the seller bears costs. After expiry of the warranty, the buyer bears the costs of transport and insurance. If the fault is covered by our warranty, you will receive a new or repaired equipment in return.

Warranty claims are invalid in case of damage resulting from:

- + misuse or improper handling
- + environmental influences (moisture, heat, electrical surge, dust, etc.)
- + failure to follow the current safety measures for the equipment
- + failure to follow the operating instructions
- + use of force (e. g. hitting, kicking, falling)
- + interventions which were not carried out by one of our authorized service centres
- + unauthorised repair attempts

Proof of Purchase and Serial Number

Please make sure that you are able to provide the appropriate receipt when claiming on your warranty. So that we can clearly identify the model of your equipment, and for the purposes of our quality control, you will need to give the serial number of your equipment, when contacting the service team. Where possible please have your serial number and your customer number ready when you call our service hotline. It will help us to deal with your request swiftly.

If you cannot find the serial number on your fitness equipment, our service team is at your disposal to offer further information.

Service outside of the Warranty Period

We are also happy to issue an individual cost estimate if there is a problem with your fitness equipment after the warranty has expired, or in cases which do not fall under the terms of the warranty, e. g. normal wear and tear. Please contact our customer service team to find a quick and cost-effective solution to your problem. In such a case you will be responsible for the delivery costs.

Communication

Many problems can be solved just by speaking to us as your specialist supplier. We know how important it is to you as a user of the fitness equipment to have problems solved quickly and simply, so you can enjoy working out with minimal interruption. For that reason, we also want to resolve your queries quickly and in a straightforward manner. Thus, please always keep your customer number and the serial number of the faulty equipment handy.

DE	DK	FR
<p>TECHNIK</p> <p> +49 4621 4210-900</p> <p> +49 4621 4210-698</p> <p> technik@sport-tiedje.de</p> <p> Öffnungszeiten entnehmen Sie unserer Homepage.</p>	<p>TEKNIK OG SERVICE</p> <p> 80 90 16 50</p> <p>+49 4621 4210-945</p> <p> info@fitshop.dk</p> <p> Åbningstider kan findes på hjemmesiden.</p>	<p>TECHNIQUE & SERVICE</p> <p> +33 (0) 189 530984</p> <p>+49 4621 42 10 933</p> <p> info@fitshop.fr</p> <p> Vous trouverez les heures d'ouverture sur notre site Internet.</p>
<p>SERVICE</p> <p> 0800 20 20277 (kostenlos)</p> <p> 04621 4210 - 0</p> <p> info@sport-tiedje.de</p> <p> Öffnungszeiten entnehmen Sie unserer Homepage.</p>	<p>PL</p> <p>DZIAŁ TECHNICZNY I SERWIS</p> <p> 22 307 43 21</p> <p>+49 4621 42 10-948</p> <p> info@fitshop.pl</p> <p> Godziny otwarcia można znaleźć na stronie głównej.</p>	<p>BE</p> <p>TECHNIQUE & SERVICE</p> <p> 02 732 46 77</p> <p>+49 4621 4210 933</p> <p> info@fitshop.be</p> <p> Vous trouverez les heures d'ouverture sur notre site Internet.</p>
UK	NL	INT
<p>CUSTOMER CARE POWERHOUSE</p> <p> +44 141 737 2249 or +44 141 876 3972</p> <p> customercare@powerhouse-fitness.co.uk</p> <p> You can find the opening hours on our homepage.</p>	<p>TECHNISCHE DIENST & SERVICE</p> <p> +31 172 619961</p> <p> info@fitshop.nl</p> <p> De openingstijden vindt u op onze homepage.</p>	<p>TECHNICAL SUPPORT & SERVICE</p> <p> +49 4621 4210-944</p> <p> service-int@sport-tiedje.de</p> <p> You can find the opening hours on our homepage.</p>
ES	AT	CH
<p>TECNOLOGÍA Y SERVICIOS</p> <p> 911 238 029</p> <p> info@fitshop.es</p> <p> Consulta nuestro horario de apertura en la página web.</p>	<p>TECHNIK & SERVICE</p> <p> 0800 20 20277 (Freecall) +49 4621 42 10-0</p> <p> info@sport-tiedje.at</p> <p> Öffnungszeiten entnehmen Sie unserer Homepage.</p>	<p>TECHNIK & SERVICE</p> <p> 0800 202 027 +49 4621 42 10-0</p> <p> info@sport-tiedje.ch</p> <p> Öffnungszeiten entnehmen Sie unserer Homepage.</p>

Please find a detailed overview including address and opening hours for all stores of Powerhouse Fitness in the UK on the following website:

www.powerhouse-fitness.co.uk/storelocator

WE LIVE FITNESS

WEBSHOP AND SOCIAL MEDIA

The Sport-Tiedje Group is Europe's largest specialist for home fitness equipment with currently 70 stores and one of the world's most renowned online mail order companies for fitness equipment.

Powerhouse Fitness is part of the Sport-Tiedje Group. Private customers order via the 25 web shops in the respective national language or have their desired equipment assembled on site. In addition, the company supplies fitness studios, hotels, sports clubs, companies and physio practices with professional equipment for endurance and strength training.

The Sport-Tiedje group offers a wide range of fitness equipment from renowned manufacturers, high-quality in-house developments and comprehensive services, such as a build-up service and sports scientific advice before and after the purchase. The company employs numerous sports scientists, fitness trainers and competitive athletes.

Visit us also on our social media platforms or our blog!



<http://www.powerhouse-fitness.co.uk/>
www.powerhouse-fitness.co.uk/blog/



<https://www.facebook.com/powerhousefitness.co.uk>



www.instagram.com/powerhousefitness_uk/



www.youtube.com/user/PHFTV/

TAURUS

 cardiostrong

BODYCRAFT

 **BodyMax**
PERFORMANCE FITNESS EQUIPMENT

Notes

Notes

Notes

TAURUS®

Treadmill T10.5 Pro