

TAURUS®

Assembly and Operating Instructions

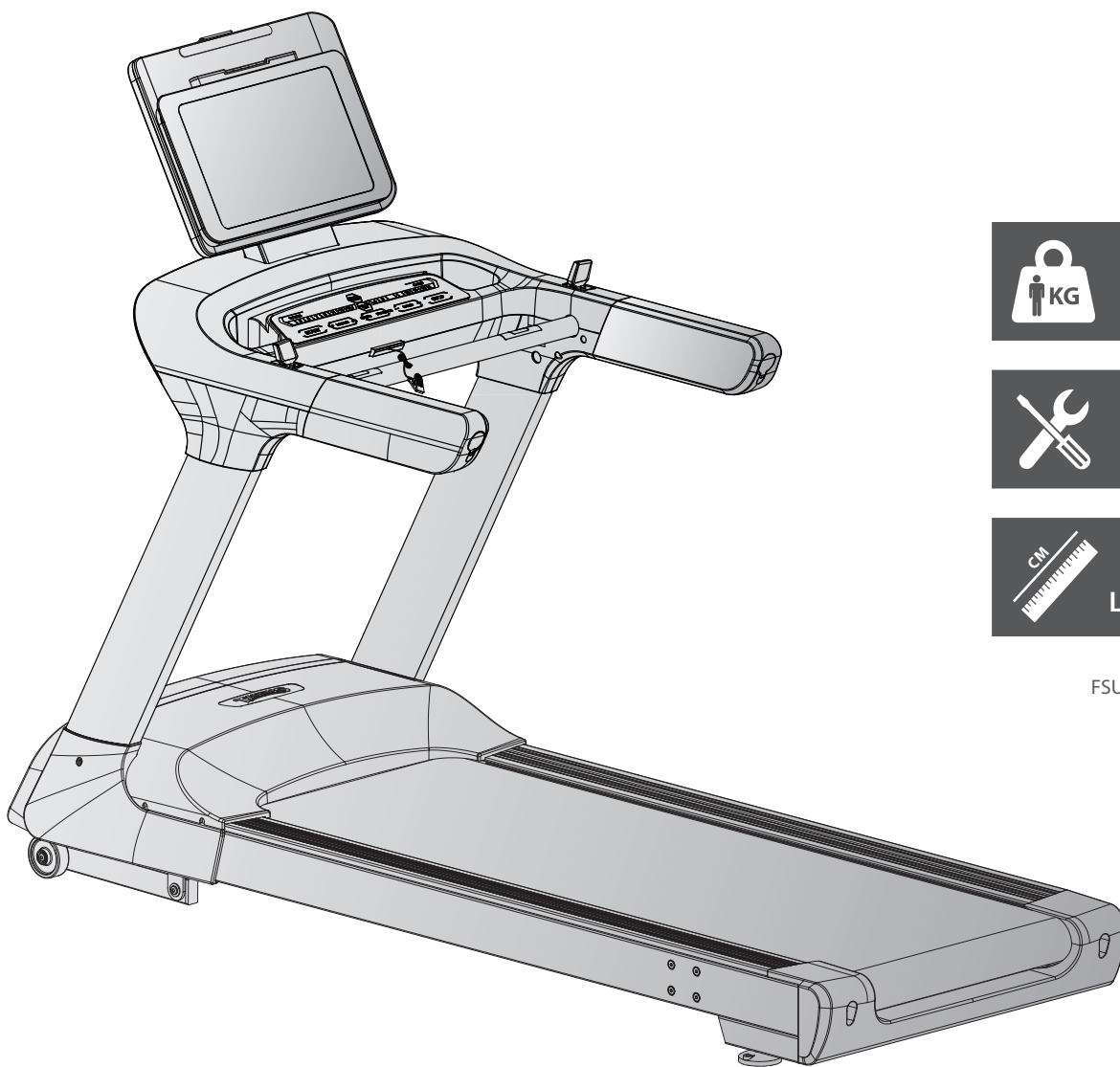

max. 200 kg



~ 60 Min. 



 144 kg

L 215 | W 85 | H 157

FSUKVMTM2517.03.02

SKU: CVTM2517

Treadmill T10.3 Pro

Content

1	GENERAL INFORMATION	8
1.1	Technical Data	8
1.2	Personal Safety	9
1.3	Electrical Safety	10
1.4	Set-Up Place	11
2	ASSEMBLY	12
2.1	General Instructions	12
2.2	Scope of Delivery	13
2.3	Assembly	14
3	OPERATING INSTRUCTIONS	20
3.1	Console Display	20
3.2	Button Function	22
3.3	Programmes	23
3.3.1	Quick Start Programme	23
3.3.2	Target programmes	23
3.3.3	Low-Speed Programme	24
3.3.4	Pre-Set Programmes	24
3.3.5	Pace Programme	29
3.3.6	User-Defined Programmes	29
3.3.7	Heart Rate Controlled Programmes	30
3.4	Fitness test	31
3.5	Media	32
3.6	Wireless Technology and Fitness Apps	33
4	STORAGE AND TRANSPORT	34
4.1	General Instructions	34
4.2	Transportation Wheels	34
5	TROUBLESHOOTING, CARE AND MAINTENANCE	35
5.1	General Instructions	35
5.2	Faults and Fault Diagnosis	35
5.3	Error Codes and Troubleshooting	36
5.4	Care and Maintenance	37
5.4.1	Adjusting the Running Mat	37
5.4.2	Re-tensioning the Running Mat	38
5.4.3	Lubricating the Running Mat	38

6.1	Maintenance and Inspection Calendar	39
6	DISPOSAL	39
7	RECOMMENDED ACCESSORIES	40
8	ORDERING SPARE PARTS	41
8.1	Serial Number and Model Name	41
8.2	Parts List	42
8.3	Exploded Drawing	47
9	WARRANTY	48
10	CONTACT	50

Dear customer,

Thank you for choosing quality training equipment from the TAURUS® brand. Taurus offers sports and fitness equipment for home users with high demands on quality, functionality and longevity. Also, Taurus is a well-known and experienced brand for equipping professional rooms for fitness studios and business customers. The focus of Taurus fitness equipment is on what matters most in sports: maximum performance! Therefore, the devices are developed in close consultation with athletes and sports scientists. Because athletes know best what makes perfect fitness equipment.

Further information can be found at www.fitshop.co.uk

Intended Use

The equipment may only be used for its intended purpose.

This fitness equipment is suitable for home use, semi-professional use and commercial or professional use. The semi-professional sector includes, for example, institutional facilities such as hospitals, schools, hotels and associations. Professional use refers to commercial use, e.g. in a fitness studio.

Legal Notice

Fitshop GmbH
Europe's No. 1 for home fitness

International Headquarters
Flensburger Straße 55
24837 Schleswig
Germany

Management:
Christian Grau
Sebastian Campmann
Dr. Bernhard Schenkel
No. HRB 1000 SL
Local Court Flensburg
European VAT Number: DE813211547

Disclaimer

© TAURUS is a registered brand of the company Fitshop GmbH. All rights reserved. Any use of this trademark without the explicit written permission of Fitshop is prohibited.

Product and manual are subject to change. Technical data can be changed without advance notice.

FITSHOP

Europas Nr.1 für Heimfitness

ABOUT THIS MANUAL

Please carefully read the entire manual before installation and first use. The manual will help you to quickly set up the system and explains how to safely use it. Make sure that all persons exercising with the equipment (especially children and persons with physical, sensory, mental or motor disabilities) are informed about this manual and its contents in advance. In case of doubt, responsible persons must supervise the use of the equipment.

Due to ongoing changes and software optimisations, the manual may have to be updated. If you notice any discrepancies during assembly or use, please refer to the manual uploaded to the webshop. The latest manual is always available there.



This equipment has been manufactured according to the latest safety knowledge. As far as possible, potential safety hazards which could cause injury have been eliminated. Make sure to carefully follow the instructions and that all parts are securely in place. If required, read through the instructions again to correct any mistakes.

Training devices must be classified according to accuracy and use. Accuracy classes are only applicable to devices that display training data.

Accuracy classes

Class A: high accuracy.

Class B: medium accuracy.

Class C: low accuracy.

The use classes explain the intended use of the training device.

Use classes

Class S (studio): professional and/or commercial use.

These training devices are intended for the use in training rooms of facilities such as sports clubs, school facilities, hotels, clubs and studios whose access and supervision is specifically regulated by the owner (person with legal responsibility).

Class H (home use): use at home.

These stationary training devices are intended for the use in private homes where access to the training device is regulated by the owner (person with legal responsibility).

Please pay close attention to the safety and maintenance instructions given here. The contract partner cannot be held liable for damage to health, accidents or damage to the equipment when it is not used in accordance with these instructions.

The following safety instructions may appear in this manual:

► **ATTENTION**

This notice indicates potentially hazardous situations which, if not avoided, may result in property damage.

⚠ **CAUTION**

This notice indicates potentially hazardous situations which, if not avoided, may result in slight or minor injuries!

⚠ **WARNING**

This notice indicates potentially hazardous situations which, if not avoided, may result in death or serious injuries!

⚠ **DANGER**

This notice indicates potentially hazardous situations which, if not avoided, will result in death or serious injuries!

ⓘ **NOTICE**

This notice indicates further useful information.

Retain these instructions in a safe place for future reference, maintenance or when ordering replacement parts.

1.1 Technical Data

TFT - Display of

- + Speed in km/h
- + Training time in min
- + Training distance in km
- + Calories in kcal
- + Heart rate (when using hand pulse sensors or chest strap)
- + Incline in %
- + Metabolic equivalent

Motor output:	3.5 HP continuous (AC motor)
Speed range:	0.5 - 24 km/h (adjustable in steps of 0.1 km/h)
Hot keys (Speed):	8
Incline range:	0 - 15 % (adjustable in steps of 1%)
Hot keys (Incline):	8
Programmes in total:	45
Quick Start programme:	1
Target programmes:	3
Low Speed programme:	1
Pre-set programmes:	32
Pace programme:	1
User-defined programmes:	4 (one per user)
Heart rate controlled programmes:	3
Fitness test:	1
Size of running surface (L x W):	160 x 56 cm

Weight and Dimensions:

Article weight (gross, incl. packaging):	164 kg
Article weight (net, excl. packaging):	144 kg
Package dimensions (L x W x H) approx.:	226 cm x 89 cm x 45 cm
Set-up dimensions (L x W x H) approx.:	215 cm x 85 cm x 157 cm
Maximum user weight:	200 kg
Use class:	S

1.2 Personal Safety

DANGER

- + Before you start using the equipment, you should consult your physician that this type of exercise is suitable for you from a health perspective. Particularly affected are persons who: have a hereditary disposition to high blood pressure or heart disease, are over the age of 45, smoke, have high cholesterol values, are overweight and/or have not exercised regularly in the past year. If you are under medical treatment that affects your heart rate, medical advice is absolutely essential.
- + Note that excessive training can seriously endanger your health. Please also note that heart rate monitoring systems can be inaccurate. If you notice any signs of weakness, nausea, dizziness, pain, shortness of breath, or other abnormal symptoms, stop exercising immediately and seek advice from your doctor if necessary.
- + The owner must communicate all warnings and instructions to the user.

WARNING

- + This equipment may not be used by children under the age of 14.
- + Children should not be allowed unsupervised access to the equipment.
- + Persons with disabilities must have a medical license and must be under strict observation when using the equipment.
- + The equipment is strictly for use by one person at a time.
- + If your equipment provides a safety key, the clip of the safety key must be attached to your clothing before starting your training. In the event of a fall, the EMERGENCY STOP of the equipment can be initiated.
- + If an emergency occurs and training has to be stopped abruptly, pull out the safety key, grab both handles, jump onto the side rails and wait until the treadmill has come to a complete stop.
- + Keep your hands, feet and other body parts, hair, clothing, jewellery and other objects well clear of moving parts.
- + During use, wear suitable sports clothing rather than loose or baggy clothing. When wearing sports shoes, make sure they have suitable soles, preferably made of rubber or other non-slip materials. Shoes with heels, leather soles, studs or spikes are unsuitable. Never exercise barefoot.

CAUTION

- + If your equipment needs to be connected to the power supply with a mains cable, make sure that the cable is not a potential tripping hazard.
- + Make sure that nobody is within the range of motion of the equipment during training so as not to endanger you or other persons.
- + Be aware that if adjustment devices are left protruding, they may impede the user's movement.

► **ATTENTION**

- + Do not insert any objects of any kind into the openings of the device.
- + To protect the equipment from use by unauthorised third parties, always remove the power cable when not in use and store it in a safe place that is inaccessible to unauthorised persons (e.g. children).

1.3 Electrical Safety

 **DANGER**

- + In order to reduce the risk of an electric shock, always unplug the equipment from the mains socket immediately after your workout, before assembly or dismantling, and before maintenance or cleaning. Do not pull on the cable.

 **WARNING**

- + Do not leave the equipment unattended while the mains cable is plugged into the mains socket. During your absence, the mains cable must be removed from the mains socket to prevent improper use by third parties or children.
- + If the mains cable or plug is damaged or defective, contact your contract partner. Until repair, the equipment must not be used.

► **ATTENTION**

- + The equipment requires a mains connection of 220-230 V with 50 Hz mains voltage.
- + The equipment may only be connected directly to an earthed socket using the supplied mains cable. Extension cables must conform to VDE guidelines. Always completely unwind the mains cable.
- + The socket must be protected by a fuse with a minimum fuse rating of "16 A, slow blow".
- + Do not make any changes to the mains cable or the mains plug.
- + Keep the mains cable away from water, heat, oil and sharp edges. Do not route the mains cable underneath the equipment or under a carpet or rug, and do not place any objects on top of it.
- + If your purchased item is equipped with a TFT console, software updates must be carried out regularly. Follow the instructions on the console to perform the update(s).
- + The software systems on gym equipment with TFT consoles are set up only for the pre-installed apps. Do not install any additional apps.

 **NOTICE**

- + The pre-installed apps on TFT consoles are produced and provided by external manufacturers. Fitshop does not take any responsibility for the availability, functionality or contents of these apps.

1.4 Set-Up Place

⚠ WARNING

- + Do not place the equipment in main corridors or escape routes.

⚠ CAUTION

- + Make sure that there is a safety area behind the treadmill with a length of at least 2 m and a width at least equal to the width of the treadmill.
- + The training room should be well ventilated during training and not be exposed to any draughts.
- + Choose the place in which to set up the equipment such that there is enough free space/clearance to the front, the rear and to the sides of the equipment.
- + The free area in the direction from which the exercise equipment is accessed must be at least 0.6 m larger than the exercise area.
- + The set-up and mounting surface of the equipment should be flat, loadable and solid.

▶ ATTENTION

- + The device may only be used in one building, in sufficiently tempered and dry rooms (ambient temperatures between 10°C and 35°C). The equipment should not be used outdoors or in rooms with high humidity (over 70%) like swimming pools.
- + A floor protective mat/equipment underlay can help to protect high-quality floor coverings (parquet, laminate, cork, carpets) from dents and sweat and can help to level out slight unevenness.
- + For Class S equipment, the exercise equipment may only be used in areas where access, supervision and control are specifically regulated by the owner.

Recommended free zone:

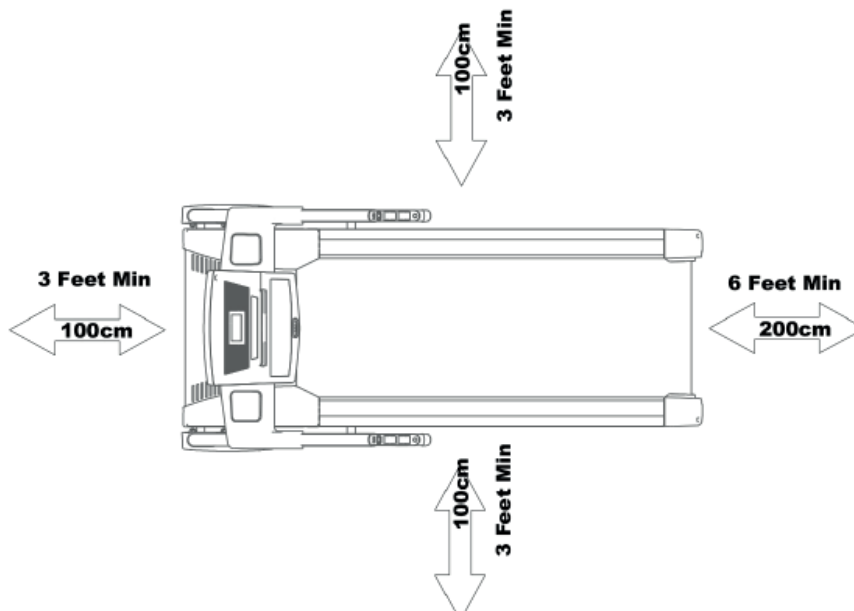

2.1 General Instructions



DANGER

- + Do not leave any tools, packaging materials such as foils or small parts lying around, as otherwise there is a danger of suffocation for children. Keep children away from the equipment during assembly.



WARNING

- + Pay attention to the instructions attached to the equipment in order to reduce the risk of injuries.



CAUTION

- + Ensure to have sufficient room for movement in each direction during assembly.
- + The assembly of the equipment must be carried out by at least two adults. If in doubt, seek the help of a third technically skilled person.



ATTENTION

- + To prevent damage to the equipment and the floor, assemble the equipment on a mat or packaging board.



NOTICE

- + In order to make the assembly as simple as possible, some screws and nuts to be used can already be pre-assembled.
- + Ideally, assemble the equipment at its later set-up place.

2.2 Scope of Delivery

The scope of delivery consist of the following parts. At the beginning, check whether all parts and tools belonging to the device are included in the scope of delivery and whether damage has occurred. In the event of complaints, the contractual partner must be contacted directly.

⚠ CAUTION

If parts of the scope of delivery are missing or damaged, the assembly must not be carried out.

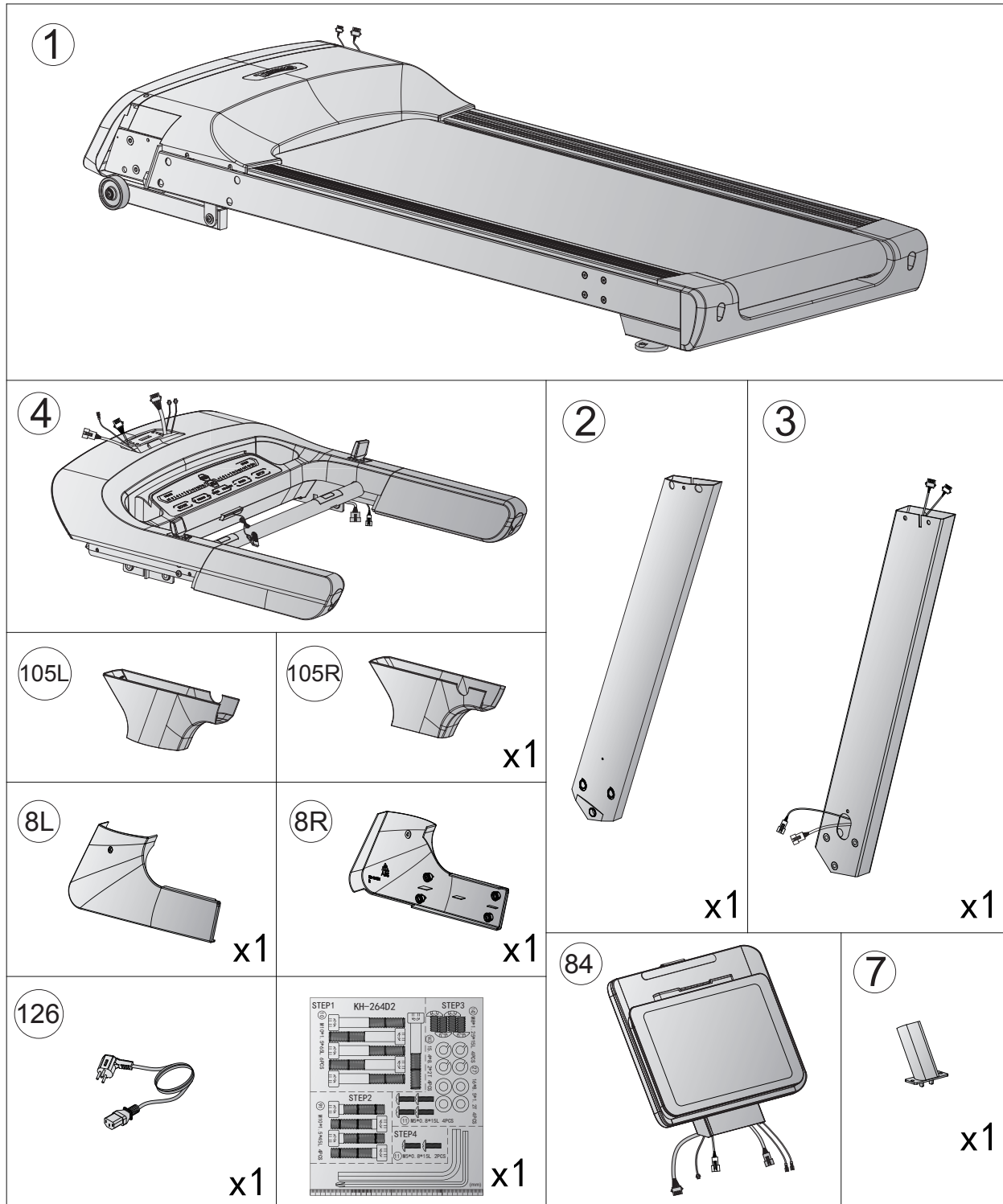

2.3 Assembly

Before assembly, take a close look at the individual assembly steps shown and carry out the assembly in the order given.

NOTICE

- + First loosely screw all parts together and check that they fit properly. Tighten the screws using the tool only when you are instructed to do so.
- + If you have difficulty recognising the graphics, we recommend that you open and/or download the PDF instructions stored in the webshop on your end device (e.g. smartphone, tablet or PC). There you have the option of zooming in closer. Please note that the Adobe Acrobat Reader programme must be installed on your end device in order to open the file.

Step 1: Assembly of the handlebar posts

1. Connect the two cables (121 and 122, 157 and 158) with one another.

► **ATTENTION**

Be careful not to pinch the cables in the following step.

2. Fix the two handlebar posts (2 and 3) to the main frame (1) with six allen bolts (10).

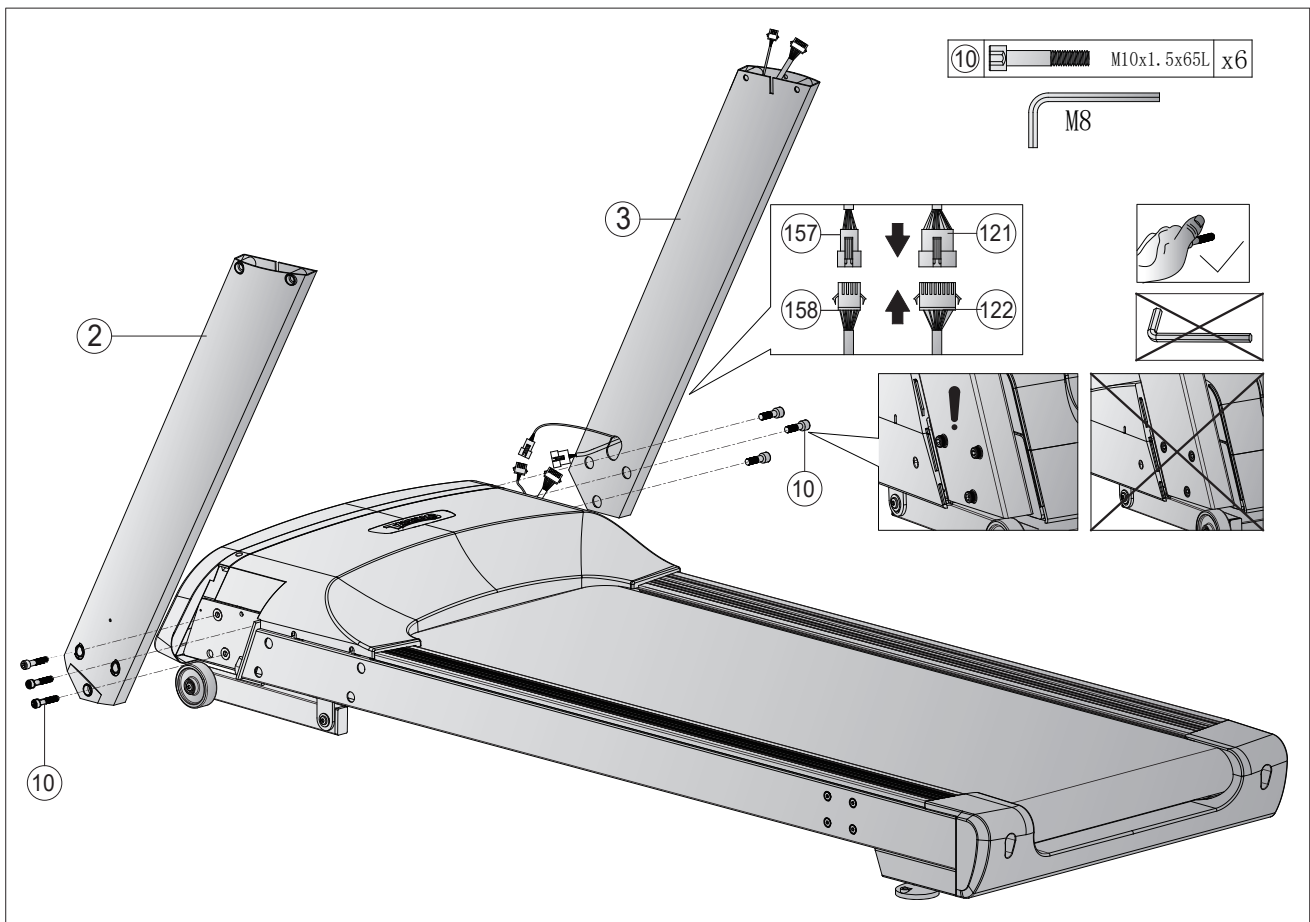

Step 2: Assembly of the handlebar

1. Slide the two covers (105L and 105R) downwards.
2. Connect the two cables (120 and 121, 156 and 157) with one another.

► **ATTENTION**

Be careful not to pinch the cables in the following step.

3. Fix the handlebar (4) to the two handlebar posts (2 and 3) with four allen screws (91).
4. Tighten the screws.

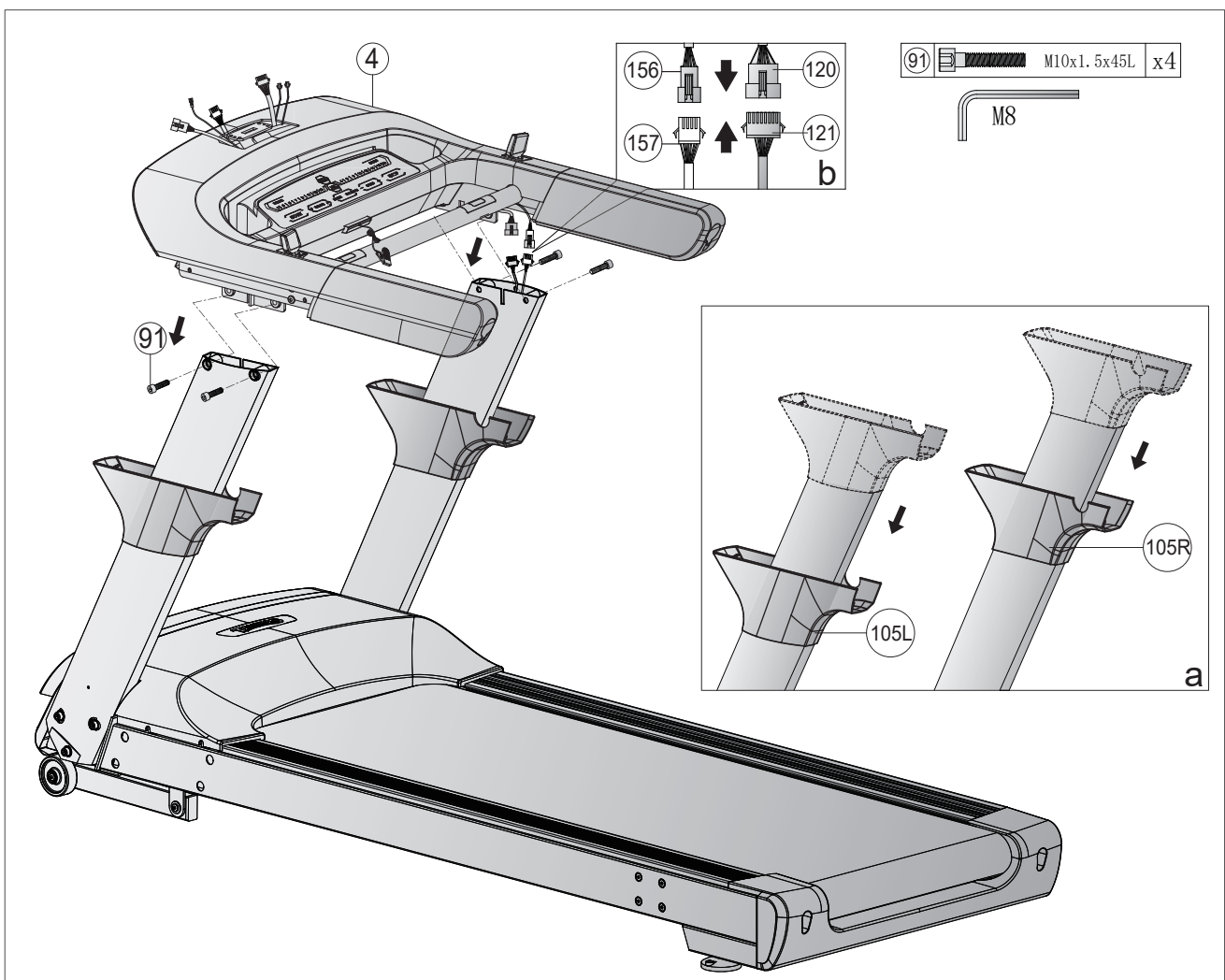

Step 3: Assembly of the console

1. Fix the supporting tube (7) to the handlebar (4) with two allen bolts (142), two spring washers (143) and two flat washers (27).
2. Connect the cables (93, 98, 118, 156 and 120) with their counterparts of the console (84).

► **ATTENTION**

Be careful not to pinch the cables in the following step.

3. Fix the console (84) to the supporting tube (7) with two allen bolts (142), two spring washers (143) and two flat washers (27).
4. Slide the covers (105L and 105R) upwards again and fix them to the handlebar (4) with four cross bolts (11).
5. Tighten the bolts.

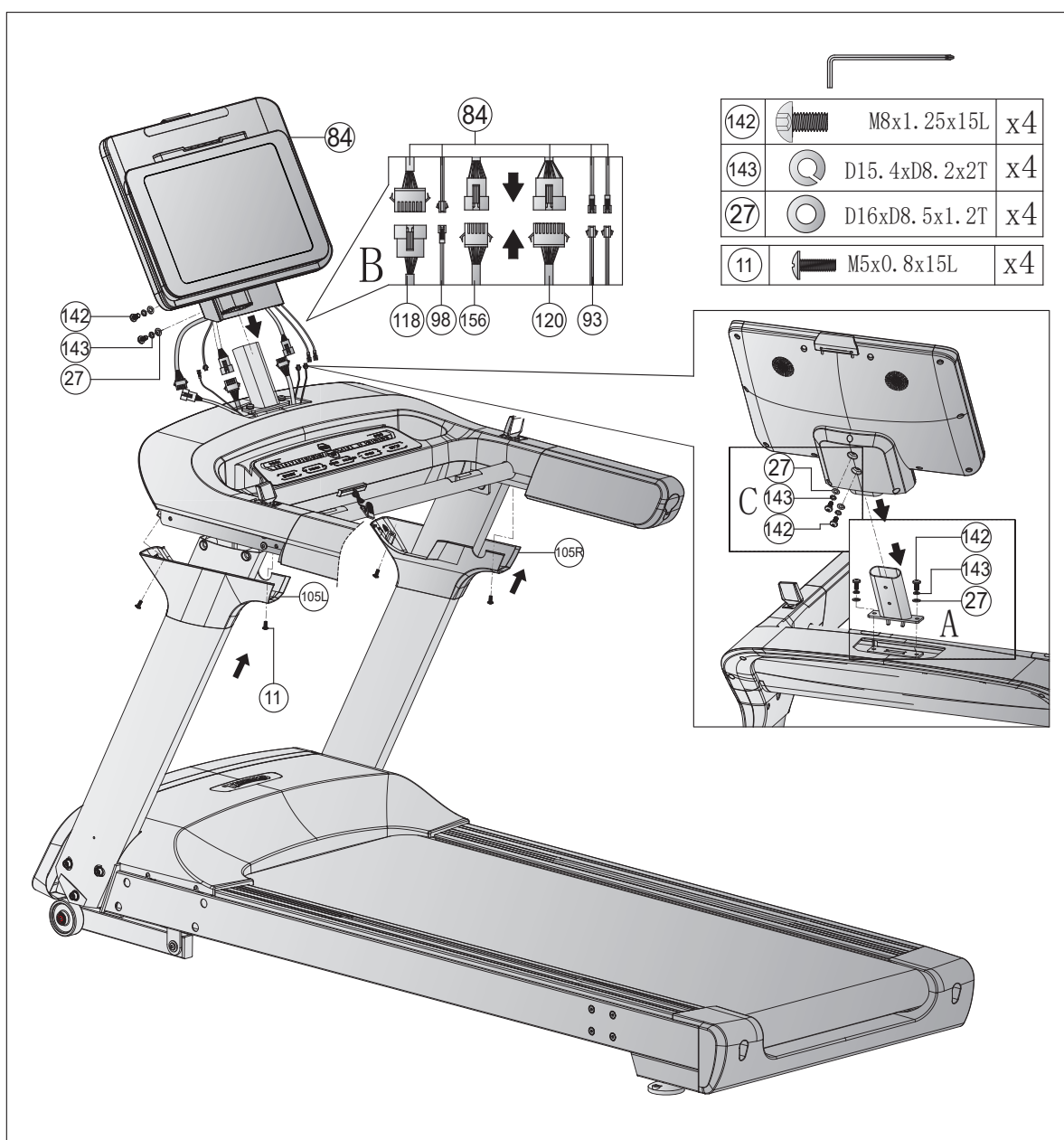

Step 4: Finish the assembly

1. Tighten the six allen bolts (10).
2. Fix the covers (8L and 8R) to the main frame (1) by pressing the lugs on the inside of the covers into the corresponding drill holes of the main frame until they engage audibly.
3. Finally fix the covers (8L and 8R) to the handlebar posts (2 and 3) with two cross bolts (11).

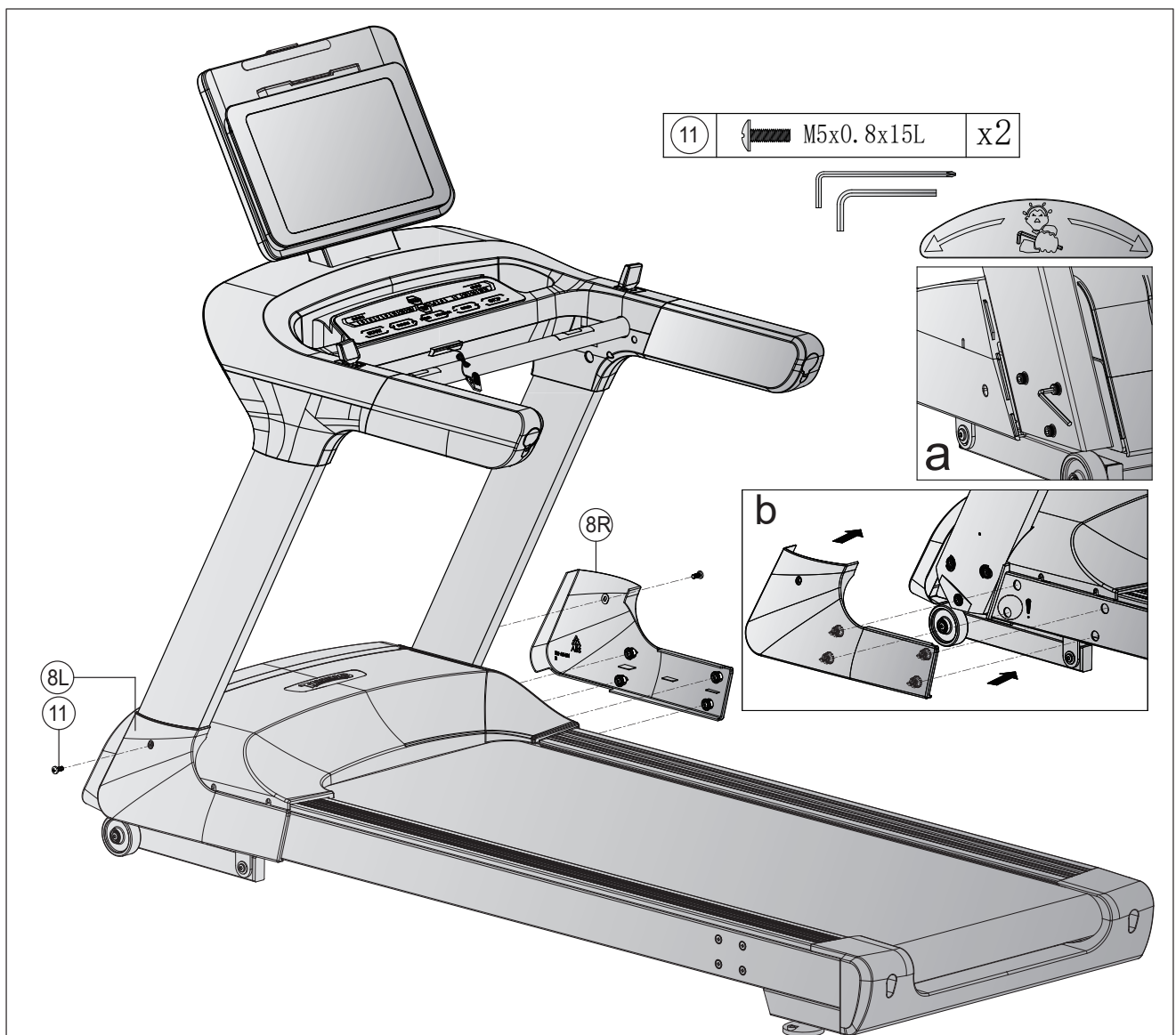

Step 5: Alignment of the feet

If the floor is uneven, you can stabilize the treadmill by turning the two setting screws under the main frame.

1. Lift the treadmill on the desired side and rotate the setting screws under the main frame.
2. Rotate the screws clockwise in order to remove them and to raise the running surface.
3. Rotate them counterclockwise in order to lower the running surface.

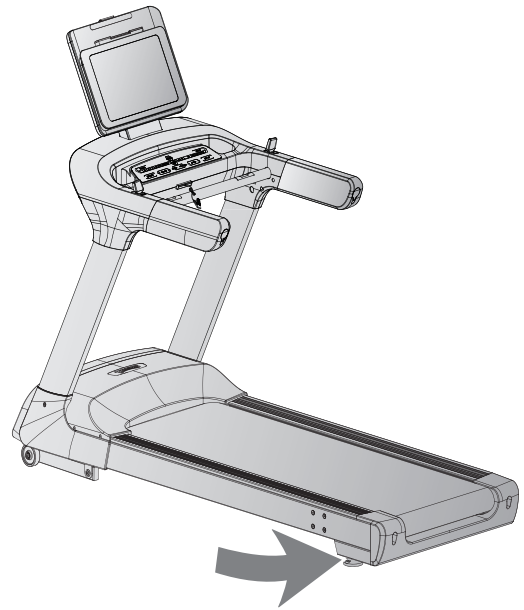

Step 6: Connecting the equipment to the mains supply

► ATTENTION

The equipment must not be connected to a multiple socket, otherwise it cannot be guaranteed that the equipment will be supplied with sufficient power. Technical errors can result.

Plug the power plug into a wall outlet that complies with the instructions in the chapter on electrical safety.

Step 7: Using the holder for mobile devices

1. Place your mobile device onto the holder (C) above the console (84).
2. Pull out the fixing hook (A) that is located on the back of the console cover and fix it at the top of your device.

ⓘ NOTICE

The scope of delivery contains a buffer strap. This can optional be stuck between your device and the console cover if there is knocking sound during workout. The buffer strap has to be stuck onto the top of the console cover.

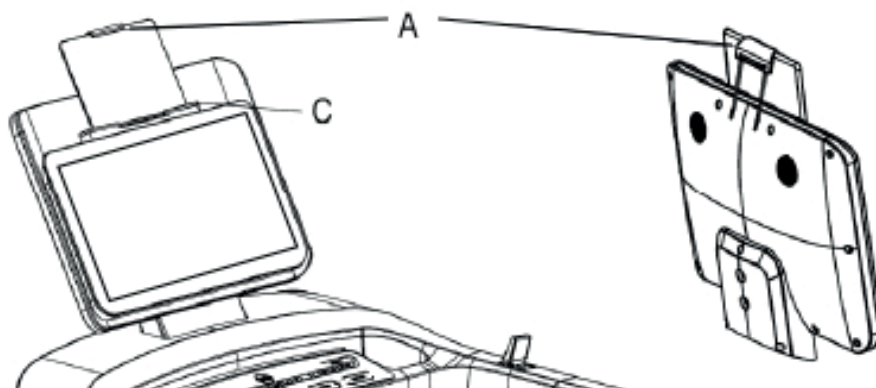

ⓘ IMPORTANT NOTICE

To ensure that your treadmill has the latest software version, please perform an update before using it for the first time. Proceed as follows:

1. Tap "Settings" in the lower right corner of the screen.
2. Tap "Wireless" and connect your treadmill to the Internet.
3. Return to the settings.
4. Tap "System".
5. Tap "Start" to update the software.

Do not use or switch off the treadmill during the update.

Check whether another update is available and carry it out as described above at regular intervals.

Correctly Getting On and Off

1. To step onto the treadmill, grip the handrails with both hands and step onto the treadmill one foot at a time.
2. To get off, grip the handrails with both hands and step off the treadmill one foot at a time.

3 OPERATING INSTRUCTIONS

NOTICE

- + Familiarise yourself with all the functions and setting options of the device before starting training. Have the proper use of this product explained to you by a specialist.
- + Always start your training with low intensity and increase evenly and gently. End your training with a cool-down phase. If you are unsure, please consult your physician.
- + Most new treadmills make a knocking noise caused by the running mat sliding over the rollers. The time it takes for the noise to subside depends on the intensity of use, the temperature and the humidity around the treadmill.
- + Please bear in mind that the noise emission under load is higher than without load.

SAFETY KEY

WARNING

- + For your safety, the device is equipped with an EMERGENCY STOP function. The equipment can only be operated if the safety key is correctly attached to the contact point of the cockpit. If the safety key is no longer on the contact point, the equipment automatically stops. Therefore, the Safety Key cord with the clip must be attached to your clothing before every training session. If you want to quickly stop the treadmill, if you can no longer control the speed, or if another emergency occurs, remove the safety key from the cockpit using the cord.
- + To enable the safety key to detach from the contact point of the cockpit in the event of a fall, the safety key clip must be firmly attached to your clothing!
- + Make sure that the safety key is not accessible to children.

3.1 Console Display



DISPLAY	DESCRIPTION
Incline	+ Display of the current incline in % + Display range: 0–15
Time	+ Display of the training time in minutes + Display range: 00:00–99:59
Distance	+ Display of the training distance in km + Display range: 0.0–9999
Calories	+ Display of the calories in kcal + Display range: 0–999
Pulse	+ Display of the current heart rate + Display range: 40–220
Speed	+ Display of the current speed in km/h + Display range: 0.5–24
Mets	+ Display of the METS + Definition: MET or metabolic equivalent is used to measure the average metabolic rate for a person. MET describes the quantity of oxygen that an average person needs when in rest. 1 MET = 3.5 ml/kg/min (The body consumes 3.5 milliliters of oxygen per kilogram per minute) is the amount of oxygen that the body needs when in rest. The more intensively the body works, the more oxygen is consumed and the higher the MET level. If you train at a level of seven METS, then you are working approximately 7 times harder than when in rest. Furthermore, you need 7 times as much oxygen than when in rest. + Training between three to six METs is seen as moderate physical activity. + Training at more than six METs is seen as strong physical activity.

3.2 Button Function

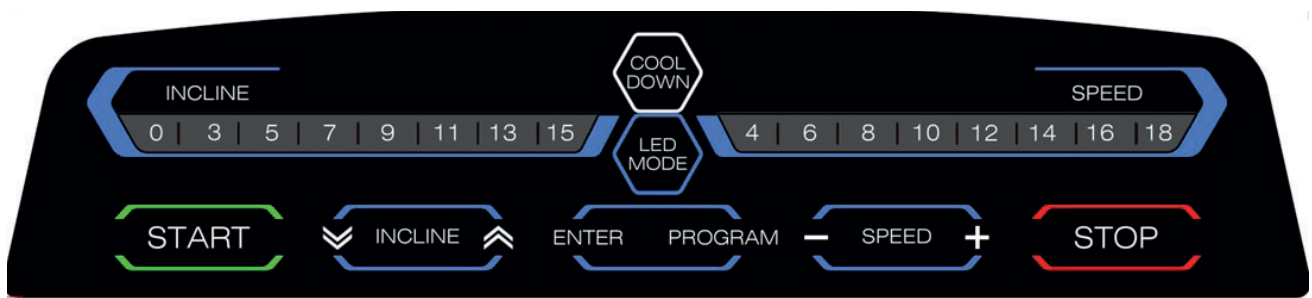

BUTTON	DESCRIPTION
START	With this button you can start a training programme. When you are in the main menu, you can start your training via quick start. When your training is paused, you can continue with your training by pressing this button.
STOP	With this button you can pause or end your training.
SPEED	With these buttons you can adjust the speed. You can adjust the speed in four ways: <ol style="list-style-type: none"> 1. The eight quick keys on the console. 2. The buttons on the console (+ and -). 3. The pushbutton on the right hand rail 4. The buttons on the touch screen. <p>NOTICE The SPEED buttons (+ and -) and the right handrail pushbutton are also used for general value setting.</p>
INCLINE	With these buttons you can adjust the incline. You can adjust the incline in three ways: <ol style="list-style-type: none"> 1. The eight quick keys on the console. 2. The arrow buttons on the console. 3. The pushbutton on the left hand rail 4. The buttons on the touch screen. <p>NOTICE The INCLINE buttons (arrow buttons) and the left handrail pushbutton are also used for general value setting.</p>
COOL DOWN	With this button you can start the cool down phase at any time. Speed and incline will be reduced until the treadmill has come to a stop and has returned to its original position.
ENTER	With this button you confirm your entries

LED MODE	With this button you can turn the LED mode on or off. Running Mode: In this mode, the LED lights glow in different colours depending on the speed level: 0-6 KPH - Yellow, 6.1-12 KPH - Green, >12 KPH - Red
PROGRAM	In the main menu, this button will take you directly to the pre-set programmes.

3.3 Programmes

This treadmill offers many different programmes. This includes: a quick start programme, three target programmes, one Low-Speed programme, 32 pre-set programmes, one Pace programme, four user-defined programmes and three heart rate-oriented programmes.

3.3.1 Quick Start Programme

When you are in the main menu, simply press START to start a training session via quick start. Alternatively you can also tap on "QUICK START" in the main menu.

3.3.2 Target programmes

1. Tap on "GOAL" in the main menu.
2. Choose either time, distance or calories as your target unit.

ⓘ NOTICE

You can only choose one unit.

3. Set a value for your desired target unit.
4. Press START to start the programme.

The programme starts with a speed of 0.5 km/h.

The speed and the incline can be adjusted manually during your training.

5. Press STOP to pause your training.

The speed will be reduced slowly until the treadmill comes to a stop. In case an incline level has been set, the treadmill will remain in that position.

- 5.1. Press STOP again to end your training. An overview of the collected training data will be displayed.
- 5.2. Press START to continue with your training.

Upon completion of the programme the console will start the cool down phase automatically.

3.3.3 Low-Speed Programme

1. Tap on "LOW SPEED" on the main menu.
2. Choose either time, distance or calories as your target unit.

① NOTICE

You can only choose one unit.

3. Set a value for your desired target unit.
4. Press START to start the programme.

The programme starts with a speed of 0.5 km/h.

The speed and the incline can be adjusted manually during your training.

① NOTICE

The programme only runs at a maximum speed of 4 km/h.

5. Press STOP to pause your training.

The speed will be reduced slowly until the treadmill comes to a stop. In case an incline level has been set, the treadmill will remain in that position.

- 5.1. Press STOP again to end your training. An overview of the collected training data will be displayed.
- 5.2. Press START to continue with your training.

Upon completion of the programme the console will start the cool down phase automatically.

3.3.4 Pre-Set Programmes

1. Tap on „PROGRAM“ in the main menu.
2. Enter your gender, age, weight and the desired training time and press Next.
3. Choose one of the pre-set programmes.
4. Press START to start the programme.

The speed and the incline can be adjusted manually during your training.

5. Press STOP to pause your training.

The speed will be reduced slowly until the treadmill comes to a stop. In case an incline level has been set, the treadmill will remain in that position.

- 5.1. Press STOP again to end your training. An overview of the collected training data will be displayed.
- 5.2. Press START to continue with your training.

Upon completion of the programme the console will start the cool down phase automatically.

Programme		Setting time / 30 = time for each section														
		1	2	3	4	5	6	7	8	9	10	11	12	13	14	15
P1	SPEED	2	2	4	4	3	3	4	3	5	4	2	2	5	5	3
	INCLINE	1	1	2	2	3	3	3	1	2	2	3	3	2	2	2
P2	SPEED	2	2	5	5	4	4	6	4	6	4	2	2	4	4	2
	INCLINE	1	1	2	2	3	3	3	2	2	3	4	4	2	2	2
P3	SPEED	2	2	5	5	4	4	5	4	5	4	2	2	3	3	2
	INCLINE	1	1	2	2	2	2	3	1	2	2	2	2	2	2	1
P4	SPEED	3	3	6	6	7	7	5	8	5	9	6	6	4	4	3
	INCLINE	2	2	2	2	3	3	3	2	2	4	6	6	2	2	2
P5	SPEED	3	3	6	6	7	7	5	8	6	7	6	6	4	4	3
	INCLINE	1	1	2	2	4	4	3	2	2	4	5	5	2	2	1
P6	SPEED	2	2	8	8	6	6	4	5	9	7	5	5	4	4	3
	INCLINE	2	2	2	2	6	6	2	3	4	2	2	2	2	2	1
P7	SPEED	2	2	6	6	7	7	4	4	7	4	2	2	4	4	2
	INCLINE	4	4	5	5	6	6	6	9	9	10	7	7	6	6	3
P8	SPEED	2	2	4	4	6	6	8	7	8	6	2	2	3	3	2
	INCLINE	3	3	5	5	4	4	4	3	4	4	3	3	3	3	2
P9	SPEED	2	2	4	4	5	5	5	6	5	6	3	3	3	3	2
	INCLINE	3	3	5	5	3	3	4	2	3	4	2	2	3	3	2
P10	SPEED	2	2	3	3	5	5	3	3	5	3	6	6	3	3	3
	INCLINE	4	4	4	4	3	3	6	7	8	8	6	6	3	3	3
P11	SPEED	3	3	5	5	8	8	8	9	5	7	6	6	3	3	2
	INCLINE	4	4	5	5	6	6	6	9	9	10	8	8	6	6	3
P12	SPEED	2	2	5	5	5	5	4	4	6	4	2	2	3	3	4
	INCLINE	3	3	5	5	6	6	7	8	9	10	10	8	6	6	3
P13	SPEED	4	4	2	2	6	6	8	6	3	2	6	6	2	2	2
	INCLINE	3	3	4	4	6	6	2	3	7	9	5	5	2	2	2
P14	SPEED	3	3	4	4	4	4	3	5	5	6	3	3	3	3	2
	INCLINE	3	3	5	5	4	4	4	3	4	3	2	2	2	2	4
P15	SPEED	4	4	2	2	4	4	6	8	7	8	6	6	2	2	3
	INCLINE	4	4	3	3	4	4	4	3	4	2	3	3	2	2	5
P16	SPEED	3	3	2	2	5	5	7	3	5	6	7	7	2	2	1
	INCLINE	3	5	9	10	9	9	8	8	4	3	3	3	2	2	4
P17	SPEED	2	4	6	8	8	10	10	8	10	10	5	5	9	9	8
	INCLINE	1	1	4	4	6	6	6	1	4	4	6	6	4	4	4

Programme		Setting time / 30 = time for each section														
		16	17	18	19	20	21	22	23	24	25	26	27	28	29	30
P1	SPEED	3	2	2	4	4	5	5	5	6	5	6	3	3	3	3
	INCLINE	2	3	3	5	5	3	3	4	2	3	4	2	2	3	3
P2	SPEED	2	2	2	4	4	6	6	8	7	8	6	2	2	3	3
	INCLINE	2	3	3	5	5	4	4	4	3	4	4	3	3	1	1
P3	SPEED	2	2	2	4	4	5	5	5	6	5	6	3	3	3	3
	INCLINE	1	3	3	5	5	3	3	4	2	3	4	2	2	3	3
P4	SPEED	3	4	4	2	2	6	6	8	6	3	2	6	6	2	2
	INCLINE	2	3	3	4	4	6	6	2	3	7	9	5	5	2	2
P5	SPEED	3	2	2	5	5	5	5	4	4	6	4	2	2	3	3
	INCLINE	1	3	3	5	5	6	6	7	8	9	10	10	8	2	2
P6	SPEED	3	4	4	2	2	4	4	6	8	7	8	6	6	2	2
	INCLINE	1	4	4	3	3	4	4	4	3	4	2	3	3	2	2
P7	SPEED	2	3	3	5	5	4	4	4	3	4	3	2	2	2	2
	INCLINE	3	4	4	2	2	4	4	6	8	7	8	6	6	2	2
P8	SPEED	2	3	3	5	5	4	4	4	3	4	3	2	2	2	2
	INCLINE	2	4	4	2	2	4	4	6	8	7	8	6	6	2	2
P9	SPEED	2	3	3	4	4	4	4	3	5	5	6	3	3	3	3
	INCLINE	2	3	3	5	5	4	4	4	3	4	3	2	2	2	2
P10	SPEED	3	4	4	3	3	4	4	4	3	4	2	3	3	2	2
	INCLINE	3	3	3	2	2	5	5	7	3	5	6	7	7	2	2
P11	SPEED	2	3	3	4	4	6	6	2	3	7	9	5	5	2	2
	INCLINE	3	3	3	4	4	4	4	3	5	5	6	3	3	3	3
P12	SPEED	4	3	3	4	4	3	3	4	3	5	4	2	2	1	1
	INCLINE	3	5	5	3	3	4	4	4	3	4	2	5	5	2	2
P13	SPEED	2	3	3	10	10	7	7	10	7	10	7	7	7	2	2
	INCLINE	2	1	1	2	2	4	4	5	2	2	4	6	6	3	3
P14	SPEED	2	5	5	3	3	4	4	4	3	4	2	5	5	2	2
	INCLINE	4	2	2	5	5	4	4	2	4	2	4	2	2	4	4
P15	SPEED	3	2	2	5	5	4	4	2	4	2	4	2	2	4	4
	INCLINE	5	1	1	2	2	3	3	3	2	2	3	4	4	2	2
P16	SPEED	1	2	2	5	5	4	4	5	4	5	4	6	6	3	3
	INCLINE	4	1	1	2	2	2	2	3	1	2	2	1	1	2	2
P17	SPEED	8	5	5	4	4	3	4	3	4	5	6	3	3	3	3
	INCLINE	4	3	3	5	5	4	4	2	2	3	4	2	2	3	3

Programme		Setting time / 30 = time for each section														
		1	2	3	4	5	6	7	8	9	10	11	12	13	14	15
P18	SPEED	3	5	10	10	7	7	8	10	8	10	10	10	7	7	5
	INCLINE	1	1	4	4	4	4	6	1	4	4	6	6	8	8	4
P19	SPEED	3	3	7	7	5	5	7	6	10	7	3	3	10	10	5
	INCLINE	1	1	2	2	4	4	5	1	2	2	4	4	3	3	3
P20	SPEED	3	3	10	10	7	7	10	7	10	7	7	7	7	7	3
	INCLINE	1	1	2	2	4	4	5	2	2	4	6	6	3	3	2
P21	SPEED	3	3	4	4	3	3	4	3	5	4	2	2	5	5	3
	INCLINE	2	2	3	3	4	4	4	3	4	2	5	5	2	2	5
P22	SPEED	2	2	5	5	4	4	2	4	2	4	2	2	4	4	2
	INCLINE	1	1	2	2	3	3	3	2	2	3	4	4	2	2	3
P23	SPEED	2	2	5	5	4	4	5	4	5	4	6	6	3	3	2
	INCLINE	1	1	2	2	2	2	3	1	2	2	1	1	2	2	1
P24	SPEED	3	3	6	6	5	7	5	8	5	9	6	6	4	4	3
	INCLINE	1	1	2	2	3	3	3	2	2	4	6	6	2	2	1
P25	SPEED	4	4	6	6	7	7	5	8	6	7	6	6	5	5	3
	INCLINE	1	1	3	3	4	4	3	2	2	4	5	5	2	2	1
P26	SPEED	2	2	8	8	6	6	5	5	6	7	5	5	4	4	3
	INCLINE	1	1	4	4	6	6	2	3	4	2	2	2	2	2	1
P27	SPEED	2	2	6	6	7	7	4	4	7	4	3	3	4	4	2
	INCLINE	4	4	5	5	6	6	7	9	9	10	10	10	6	6	3
P28	SPEED	4	4	2	2	5	6	8	7	8	6	5	4	3	3	2
	INCLINE	3	3	5	5	4	4	4	3	4	4	3	3	3	3	2
P29	SPEED	2	5	6	6	3	4	3	4	5	6	3	3	3	3	2
	INCLINE	3	3	5	5	4	4	2	2	3	4	2	2	3	3	2
P30	SPEED	3	5	3	3	5	5	4	4	5	3	6	6	3	4	3
	INCLINE	4	4	1	1	3	3	6	7	8	8	7	7	3	3	3
P31	SPEED	3	3	5	5	8	8	8	9	5	7	5	6	4	4	2
	INCLINE	1	3	6	5	6	5	6	9	9	10	10	10	8	6	4
P32	SPEED	2	4	5	4	5	5	6	8	6	4	3	2	3	3	4
	INCLINE	3	3	5	5	6	6	7	8	9	10	10	10	7	6	3

Programme		Setting time / 30 = time for each section														
		16	17	18	19	20	21	22	23	24	25	26	27	28	29	30
P18	SPEED	5	7	7	10	10	9	9	8	8	4	3	3	3	2	2
	INCLINE	4	5	5	10	10	8	8	10	8	10	10	5	5	2	1
P19	SPEED	5	4	4	6	6	7	7	5	8	6	7	6	6	3	1
	INCLINE	3	1	1	3	3	4	4	3	2	2	4	5	5	2	2
P20	SPEED	3	4	4	6	6	7	7	5	8	6	7	6	6	3	3
	INCLINE	2	1	1	3	3	4	4	3	2	2	4	5	5	2	2
P21	SPEED	3	2	2	8	8	6	6	5	5	6	7	5	5	4	1
	INCLINE	5	5	5	4	4	6	6	2	3	4	2	2	2	2	2
P22	SPEED	2	3	3	5	5	4	4	4	3	4	4	3	3	3	3
	INCLINE	3	5	5	4	4	3	4	3	4	5	6	3	3	3	3
P23	SPEED	2	3	3	5	5	8	8	8	9	5	7	5	6	4	2
	INCLINE	1	5	5	6	5	6	5	6	9	9	10	10	8	6	3
P24	SPEED	3	2	2	8	8	6	6	5	5	6	7	5	5	4	4
	INCLINE	1	5	5	4	4	6	6	2	3	4	2	2	2	2	2
P25	SPEED	3	4	4	2	2	5	6	8	7	8	6	5	4	3	3
	INCLINE	1	3	3	5	5	4	4	4	3	4	4	3	3	3	3
P26	SPEED	3	2	2	5	5	5	5	4	4	6	4	2	2	3	3
	INCLINE	1	3	3	5	5	6	6	7	8	9	10	10	8	6	2
P27	SPEED	2	4	4	5	5	6	6	6	9	9	10	8	8	6	3
	INCLINE	3	2	2	5	5	5	5	4	4	6	4	2	2	3	3
P28	SPEED	2	5	5	3	3	4	4	4	3	4	2	5	5	2	2
	INCLINE	2	2	2	5	5	4	4	2	4	2	4	2	2	1	1
P29	SPEED	2	4	4	3	3	4	3	5	4	2	2	5	5	3	3
	INCLINE	2	3	3	4	4	4	3	4	2	5	5	2	2	1	1
P30	SPEED	2	3	3	4	4	3	3	4	3	5	4	2	2	2	1
	INCLINE	3	5	5	3	3	4	4	4	3	4	2	5	5	2	2
P31	SPEED	2	4	4	5	5	6	6	6	9	9	10	8	8	6	3
	INCLINE	3	2	2	5	5	5	5	4	4	6	4	2	2	3	3
P32	SPEED	4	3	3	10	10	7	7	10	7	10	7	7	7	3	3
	INCLINE	3	1	1	2	2	4	4	5	2	2	4	6	6	3	3

3.3.5 Pace Programme

1. Tap on "PACE" in the main menu.
2. Set the time and distance.
3. Press START to start the programme.

The speed and the incline can be adjusted manually during your training.

4. Press STOP to pause your training.

The speed will be reduced slowly until the treadmill comes to a stop. In case an incline level has been set, the treadmill will remain in that position.

- 4.1. Press STOP again to end your training. An overview of the collected training data will be displayed.
- 4.2. Press START to continue with your training.

Upon completion of the programme the console will start the cool down phase automatically.

3.3.6 User-Defined Programmes

1. Tap on "USER PROGRAM" in the main menu.
2. Choose one of the four user profiles (U1-U4).

NOTICE

The chosen user profile will be displayed on the upper border of the screen. The name of the user profile can be changed. To do this, simply tap on the user profile and type in the desired name.

3. Enter your gender, age, weight and the desired training time.
4. Set the desired speed and incline for all the 30 segments.
5. Press START to start the programme.

The speed and the incline can be adjusted manually during your training.

6. Press STOP to pause your training.

The speed will be reduced slowly until the treadmill comes to a stop. In case an incline level has been set, the treadmill will remain in that position.

- 6.1. Press STOP again to end your training. An overview of the collected training data will be displayed.
- 6.2. Press START to continue with your training.

Upon completion of the programme the console will start the cool down phase automatically.

3.3.7 Heart Rate Controlled Programmes

WARNING

Your training equipment is not a medical device. The heart rate measurement of this equipment may be inaccurate. Various factors can affect the accuracy of the heart rate measurement. The heart rate measurement serves only as a training aid.

There are three different heart rate-oriented programmes. Either choose one of the pre-set target heart rates (60% or 80% of your maximum heart rate) or choose „Target HR“ to set a target heart rate yourself. Your maximum heart rate is calculated depending on your age. We recommend a chest strap for these programmes.

1. Tap on „HRC“ in the main menu.
2. Enter your gender, age, weight and the desired training time.
3. Choose either 60%, 80% or Target HR.
 - 3.1. If you have chosen Target HR you will be able to set the target value yourself (between 72-168).
4. Press START to start the programme.

The incline can be adjusted manually during your training.

NOTICE

During the heart rate controlled programme the speed cannot be adjusted manually.

5. Put your hands around the hand pulse sensors or use a chest strap.

NOTICE

If the console does not receive a pulse for 15 seconds, the display will show “NO HR DETECTED” and the programme will end.

6. Press the STOP to pause your training.

The speed will be reduced slowly until the treadmill comes to a stop. In case an incline level has been set, the treadmill will remain in that position.

- 6.1. Press the STOP again to end your training. An overview of the collected training data will be displayed.
- 6.2. Press the START to continue with your training.

Upon completion of the programme the console will start the cool down phase automatically.

3.4 Fitness test

The fitness test consists of two phases. One is the warm up phase and the other is the actual fitness test. We recommend a chest strap for this test.

NOTE

The speed will be adjusted automatically in dependence of your heart rate. The incline can not be adjusted.

1. Tap on "FITNESS TEST" in the main menu.
2. Enter your gender, age and weight.
3. Press the START to start the fitness test.

The warm up phase will start.

NOTICE

We recommend to use this phase if you have not done a warm up beforehand. Otherwise the warm up phase can be skipped by tapping on "SKIP WARM UP".

4. Put your hands around the hand pulse sensors or use a chest strap.

NOTICE

In case the console does not receive a signal for 15 seconds the programme will be stopped. If your heart rate gets to high the console will display "OVER PULSE". In this case, please interrupt your test immediately.

Upon completion of the test an overview of the collected training data will be displayed.



3.5 Media

Here you will find many different apps like YouTube, Twitter, Facebook or Instagram.

IMPORTANT NOTE

To make sure the preinstalled apps are working correctly, you will have to update them from time to time. The apps that need to be updated will give you a message. To update the app, you need to have a google account. A google email is sufficient. Just follow the instructions to perform the update.

Please note: The system is set up for the pre-installed apps. Please do not install any additional apps as their proper functionality can not be guaranteed. They might even cause technical difficulties.

This menu can be opened in two ways:

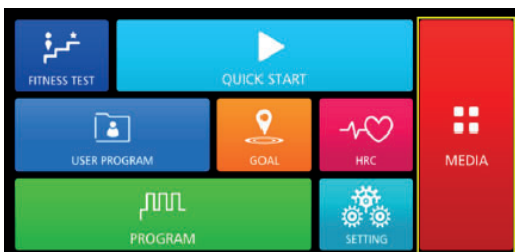

1. Via the main menu by tapping on „MEDIA“ or
2. Via the training interface (in the upper left corner of the screen).

NOTE

You can show and hide the training interface by tapping on the round icon on the right edge of the screen. To adjust the volume simply tap on the speaker icon.



You can transmit music and video data from your USB stick to the console. To do this insert your USB stick into the corresponding slot on the side of the console.

Supported formats:

Music: wav, .wma, .aac, .ogg, .mp3 und .flac.
Video: .mp4 und .avi.

Settings

Under „SETTINGS“ in the main menu, you can make your system settings. This includes: Language, screen brightness, volume and LED light.

Wireless Technology: You can connect your mobile device and wireless technology speakers with the console.

Wireless: Here you can connect the console with the internet.

3.6 Wireless Technology and Fitness Apps

This console is equipped with a wireless technology interface. Please take note that your mobile device needs to be compatible with the interface of the treadmill.

To use training apps you will have to activate the wireless technology function on your mobile device (tablet or smart phone) and start the fitness app. Select your fitness equipment. Please follow the instructions given in the app. You will find the name of your fitness equipment on a small sticker on the back of the console.

You will find the fitness apps in the app stores of Google or Apple. There you will find the apps "Kinomap" or "Zwift". Please note that these apps are produced by an external manufacturer. Fitshop does not take any responsibility regarding the availability, functionality or contents of these programmes.

IMPORTANT NOTE

The pre-installed apps are produced and provided by external manufacturers. Changes and availability within these apps might occur. Fitshop does not take any responsibility and can not be held liable for the availability, functionality or contents of these apps. To make sure the pre-installed apps are working correctly, they must be updated regularly. If needed, the respective app will notify you to do so. To update the app, you need a google account. A google email is sufficient. Just follow the instructions on the screen to perform the update.

Please note: The system is set up only for the pre-installed apps. Do not install any additional apps as their proper functionality can not be guaranteed. The installation of other apps might cause technical issues.

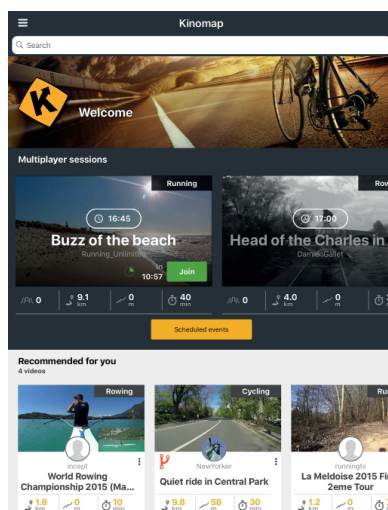
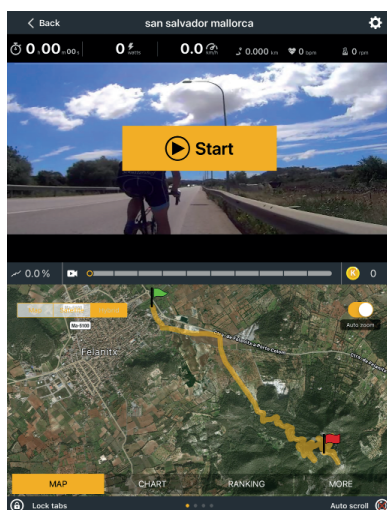
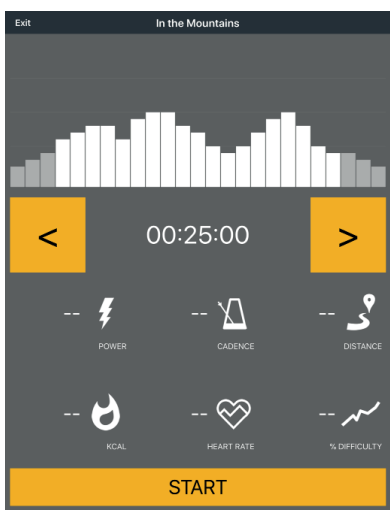

Example: Kinomap

4.1 General Instructions

WARNING

- + The storage location should be chosen so that improper use by third parties or children can be prevented.
- + If your equipment does not have transportation wheels, the equipment must be disassembled before transportation.

ATTENTION

- + Make sure that the equipment is protected from moisture, dust and dirt in the selected storage location. The storage location should be dry and well ventilated and have a constant ambient temperature between 10°C and 35°C.

4.2 Transportation Wheels

ATTENTION

If you want to transport your equipment over particularly sensitive and soft floor coverings, such as parquet, planks or laminate, lay out the transport route with cardboard or similar to avoid possible floor damage.

1. Stand behind the equipment and lift it until the weight is transferred to the transportation wheels. After that, you easily can move the equipment to a new position. For long transport distances the equipment should be disassembled and safely packed.
2. Select the new location by following the instructions in the section 1.4 of this manual.

5.1 General Instructions



WARNING

- + Do not make any improper changes to the equipment.



CAUTION

- + Damaged or worn components may affect your safety and the life of the equipment. Therefore, immediately replace damaged or worn components. In such a case, contact the contract partner. The equipment must not be used until it has been repaired. If necessary, use only original spare parts.

► ATTENTION

- + In addition to the instructions and recommendations for maintenance and care given here, additional service and/or repair work may be necessary; this must only be carried out by authorised service technicians.

5.2 Faults and Fault Diagnosis

The equipment undergoes regular quality controls during production. Nevertheless, faults or malfunctions may occur. Frequently, individual parts are responsible for these disturbances, an exchange is usually sufficient. Please refer to the following overview for the most common errors and how to correct them. If the equipment still does not function properly, contact your contract partner.

Fault	Cause	Solution
Console is not responding	Safety key missing or not inserted correctly	Check whether Safety Key is inserted and insert if necessary
Running mat slanting	Running mat not centered	Adjust the running mat according to the instructions
Grinding noises		
Running mat slips through/stops	Tape tension/lubrication not correct	Check belt tension/lubrication according to instructions
Display is blank/is not working	+ Interrupted power connection + Loose cable connections	+ Power switch to on + Check whether Safety Key is plugged in + Check cable connections
No pulse display	+ Sources of interference in the room + unsuitable chest strap + Wrong position of chest strap + Chest strap defective or battery empty + Pulse display defective	+ Eliminate sources of interference (e.g. mobile phone, WLAN, lawn mower and vacuum cleaner robot, etc. ...) + Use a suitable chest strap (see RECOMMENDED ACCESSORIES). + Reposition chest strap and/or moisten electrodes + Changing batteries + Check if pulse display by hand pulse possible

5.3 Error Codes and Troubleshooting

The electronics of the equipment continuously carries out tests. In case of deviations, an error code appears on the display and normal operation is stopped for your safety.

Please contact the contract partner for technical support.

5.4 Care and Maintenance

The most important maintenance measure is the care of the running mat. This includes adjustment, re tensioning and lubrication of the running mat. Damage resulting from insufficient or neglected care is not covered by the warranty. You should therefore carry out maintenance checks at regular intervals. Be very careful when adjusting and tightening the running mat, as a strong over voltage or under voltage can cause damage to the equipment. The running mat is adjusted at the factory according to the regulations before delivery. However, it may happen that the running mat slips during transport.

By scanning the QR-code with the camera function or QR-code scanner app of your smartphone/tablet, a video on general maintenance of a treadmill opens on YouTube. The video serves to illustrate the maintenance points described in this manual.



Please note that the video may not be available in your language or with appropriate subtitles.

If you cannot scan QR-codes, you can access all Fitshop videos on YouTube by first opening YouTube and entering "Fitshop" in the search field.

5.4.1 Adjusting the Running Mat

During training, the running mat should run as centrally and straight as possible. The alignment of the running mat can change depending on the stress and load. Another reason can be the positioning of the equipment on an uneven surface.

CAUTION

During the following maintenance nobody must be on the treadmill!

1. Let the treadmill run at a speed of 5 km/h.
2. If the running mat deviates to the left, turn the left adjusting screw at the rear end of the device max. one $\frac{1}{4}$ turn clockwise and the right adjusting screw max. one $\frac{1}{4}$ turn anticlockwise.
3. If the running mat deviates to the right, turn the right adjusting screw at the rear end of the device max. $\frac{1}{4}$ turn clockwise and the left adjusting screw max. $\frac{1}{4}$ turn anticlockwise.
4. Then observe the mat for about 30 seconds, as the change is not immediately visible.
5. Repeat this procedure until the running mat is straight again. If the running mat cannot be adjusted, please contact your contract partner.

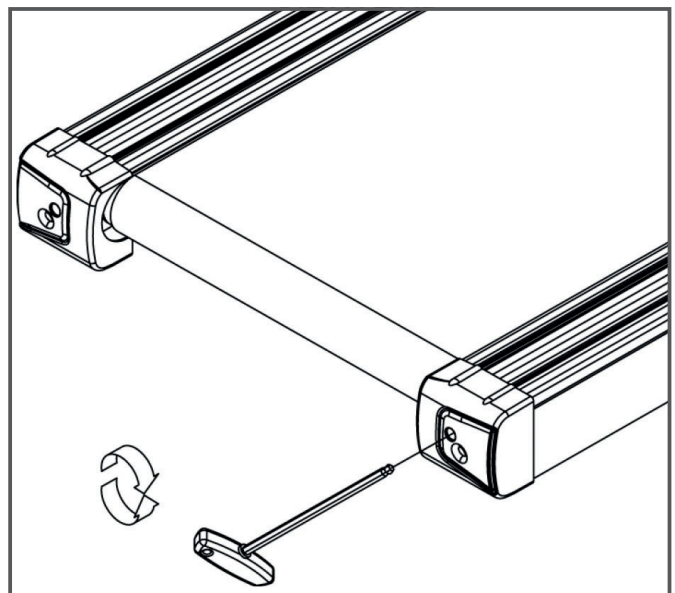

5.4.2 Re-tensioning the Running Mat

If the running mat slips over the rollers during operation (if this is the case, there is a noticeable jerk during running), the running mat must be re tightened.

In most cases, the slipping is caused by stretching of the mat through use. This is perfectly normal.

① NOTICE

Re-tensioning is carried out using the same adjusting screws that are used for adjustment.

1. Let the treadmill run at a speed of 5km/h.
2. Turn the left and right adjusting screws directly one after the other, max. one ¼ turn clockwise.
3. Then check whether the running mat continues to slip. If this is the case, you must perform the described procedure again.

5.4.3 Lubricating the Running Mat

If the running mat is not sufficiently lubricated, friction increases significantly and this leads to heavy wear of the endless belt, running plate, motor and circuit board. If you feel an increased friction of the running mat, this is an indication that you should lubricate the mat. However, lubrication should be carried out at least every 3 months or every 50 operating hours. Whichever case comes first.

① NOTICE

If your treadmill is equipped with a folding mechanism, you can also lubricate it when it is folded.

1. Raise the running mat slightly.
2. Apply some silicone oil or silicone spray to the entire deck and distribute evenly.
3. Continue turning the belt by hand so that the entire surface between the endless belt and the running plate is lubricated.
4. Wipe off the excess silicone oil or silicone spray.

① NOTICE

This maintenance must also be carried out after prolonged non-use of the equipment.

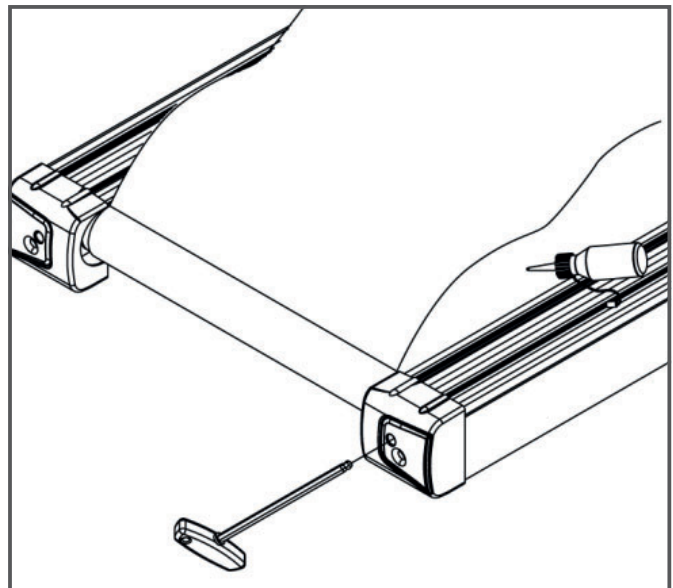

6.1 Maintenance and Inspection Calendar

To avoid damage from body sweat, the equipment must be cleaned with a damp towel (no solvents!) after each training session.

The following routine tasks must be performed at the specified intervals:

Part	Weekly	Monthly	Quarterly
Display console	C	I	
Tension of the running mat			I
Lubrication of the running mat			I
Plastic covers	C	I	
Screws and cable connections			I
Legend: C = clean; I = inspect			

By scanning the QR-code with the camera function or QR-code scanner app of your smartphone/tablet, a video on general maintenance of a treadmill opens on YouTube. The video serves to illustrate the maintenance points described in this manual.

Please note that the video may not be available in your language or with appropriate subtitles.

If you cannot scan QR-codes, you can access all Fitshop videos on YouTube by first opening YouTube and entering "Fitshop" in the search field.



6 DISPOSAL

At the end of its operational life, this equipment cannot be disposed of in normal household waste. Instead, it must be disposed of via an electricals recycling centre. Further information can be obtained from your local authority's recycling service.

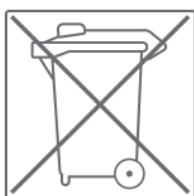

The materials can be recycled as per their symbols. Through the reuse, recycling of materials or other forms of recovery of old equipment, you make an important contribution to the protection of the environment.

7 RECOMMENDED ACCESSORIES

To make your training experience even more efficient and pleasant, we recommend that you add suiting accessories to your fitness equipment. For treadmills this could for example be a **floor mat**, which makes your fitness equipment stand more securely and also protects the floor from sweat or **silicone spray** to keep moving parts in good shape and lubricate the running mat. Furthermore, there are additional **handrails** available for some treadmills.

If you have purchased a fitness machine with pulse training and want to train your heart rate, we strongly recommend that you use a compatible **chest strap**, as this ensures optimum transmission of the heart rate.



Our range of accessories offers the highest quality and makes training even better. If you would like to find out more about compatible accessories, please go to the detail page of the product in our webshop (the easiest way is to enter the article number in the search field above) and go to the recommended accessories on this page. Alternatively, you can use the QR code provided. Of course, you can also contact our customer service: by telephone, e-mail, in one of our branches or via our social media channels. We will be happy to advise you!



floor mat



chest strap



handrails



lubricant

8.1 Serial Number and Model Name

In order to provide you with the best possible service, please have the model name, article number, serial number, exploded drawing and parts list ready. The corresponding contact options can be found in chapter 10 of this operating manual.

NOTICE

The serial number of your equipment is unique. It's located on a white sticker. The exact position of this sticker is shown in the following illustration.

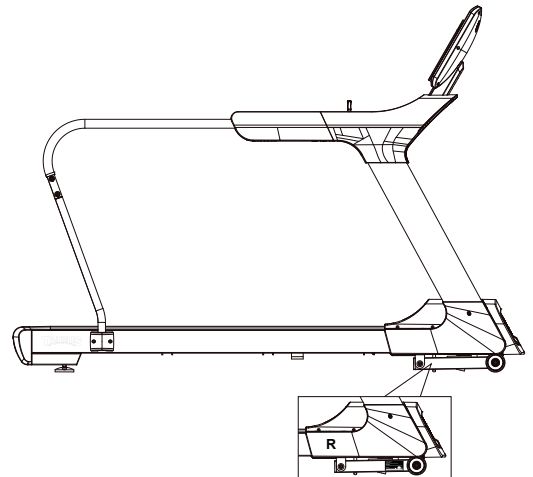

Enter the serial number in the appropriate field.

Serial number:

Brand / Category:

Model Name:

SKU:

8.2 Parts List

No.	Name	Supplier Parts No.	Specification	Qty.
1	Main frame	264A2-3-1000-J0		1
2	Left handlebar post	264A1-3-1300-J1		1
3	Right handlebar post	264A1-3-1400-J1		1
4	Handlebar set	264A1-3-1500-J2		1
5	Front handlebar set	264A1-3-1550-J0		1
6	Stabilizer	26200-3-1600-J1		1
7	Computer supporting tube	264A1-3-2000-J0		1
8L	Lower cover for handlebar post(left)	264A1-6-1371-B0	520.7*225.6*52.3	1
8R	Lower cover for handlebar post(right)	264A1-6-1471-B0	520.7*225.6*52.3	1
9	Open plug	264A1-6-2420-B0	D22.5*13.5	8
10	Allen bolt	54010-8-0065-CU7	M10*1.5*65L	6
11	Cross bolt	52605-2-0015-F0	M5*0.8*15L	13
12	CSK inner hexagon bolt	51608-5-0035-F0	M8*1.25*35L	8
13	Wooden board	26200-6-1073-B1	1445*695*25T	1
14	Buffer bar	26200-6-1084-B0	25*2T*1435L	2
15	CSK inner hexagon bolt	51608-5-0025-F0	M8*1.25*25L	8
16	Flat washer	55104-1-1210-NA	D12*D4.3*1.0T	4
17	Running belt	264A2-6-1072-B0	560*4.3T*3410L	1
20	Pedaling plate	264A2-6-1076-B0	105*21.4*1455L	2
23	Cross self-tapping screw	52842-2-0015-F0	ST4.2*15L	62
24	Metal clip	26000-6-1086-FC0	D27*D4.3*2T	8
25	Buffer(4)	26100-6-1088-F0	D30*37L*M8	2
26	Buffer(3)	26100-6-1083-B0	D30*37L*M8	2
27	Flat washer	55108-1-1612-FA	D16*D8.5*1.2T	10
28	Nylon nut	55208-1-2008-FA	M8*1.25*8T	10
29	Allen bolt	50308-5-0020-UFO	M8*1.25*20L	4
30	Rear roller set	26200-3-1200-01	D25*D75*686L	1
31	Inner hex head screw	54010-8-0080-F0	M10*1.5*80L	3
32	Rear cover	264A1-6-2406-B0	789.6*164.7*164.6	1
33	Buffer(1)	26100-6-1081-R0	D30*37L*M8	4
34	Nylon universal adjusting feet	26200-6-1094-B0	D80*81L	2

35	Front roller set	26200-3-1100-02	D25*D75*694L	1
36	Inner hex head screw	54010-5-0045-F4	M10*1.5*45L	1
37	Multi-groove belt	58004-6-1100-00	250/PJ10	1
38	Motor	261A3-6-1085-00	AC3.0HP	1
39	Nylon nut	55210-1-2010-CA	M10*1.5*10T	6
40	Flat washer	55110-1-2020-CA	D20*D11*2T	12
41	Inner hex head screw	54010-5-0030-C0	M10*1.5*30L	4
42	Flat washer	551E1-1-2820-NA	D28*D14*2T	4
43	Insulating sleeve(1)	26200-6-1063-B0	D20*D10*8T	5
44	Motor buffer	26200-6-1093-B0	65*40*5T	4
45	Fixing plate	26200-6-1071-N0	30*20*4T	3
46	Bolt	50108-5-0060-N0	M8*1.25*60L	1
47	Fixing bracket for motor cover	26100-6-1090-00	32*18*18	4
48	cable tie base	26100-6-1089-00	15*10	2
49	Cross screw	50904-2-0015-N0	ST4*1.41*15L	2
51	Upper motor cover	264A1-6-2401-B0	800*486*129.5	1
52	Al plate with logo on motor cover	264A1-6-2404-B0		1
53	Socket	26100-6-2413-00		1
54	Cross screw	53329-2-0009-D0	ST2.9x9.5L	31
55	Power supplier board	26100-6-2414-B0	130*45*6T	1
56	Switching mode power supplier	261D8-6-2411-00		1
57	Buffer	55308-4-0020-G9	D10.5*20L	2
58	overcurrent protector	261D1-6-2412-00	15A	1
59	Flat washer	55105-1-1208-DA	D12*D5.2*0.8T	2
60	Nylon nut	55205-1-2005-DA	M5*0.8*5T	2
61	Lower motor cover	264A1-6-2402-B0	812.5*237.2*180.6	1
62	Allen bolt	54010-8-0050-C4	M10*1.5*50L	1
63	Plastic flat washer	55110-1-2404-BF	D10*D24*0.4T	4
64	Incline	26200-6-1975-02	JS19-B	1
65	Allen bolt	54010-8-0065-C4	M10*1.5*65L	1
66	Wheel	26200-6-1087-B0	D82*35L	2
67	Allen bolt	50308-5-0020-UF0	M8*1.25*20L	6
68	Flat washer	55108-1-2115-FA	D21*D8.5*1.5T	2
69	End cap	55310-2-2550-B8	25*50*14	4
70	Axle	26200-6-1673-N0	D18.7*41L	2

71	Nylon washer	55121-1-3730-0F	D21*D37*3T	4
72	Flat washer	55108-1-2520-FA	D25xD8.5x2T	4
73	Buffer	55308-2-0010-B3	D26*10*M8*1.25	2
74	Upper fixing plate for handle pulse	737L6-6-2491-B0	40*15.2,W/LOGO	2
75	Allen bolt	50308-5-0050-F3	M8*1.25*50L	2
76	Allen bolt	50308-5-0055-F3	M8*1.25*55L	1
77	Handle pulse sensor	737L6-6-2478-00	100.3*29.5*0.4T	4
78	Lower fixing plate for handle pulse	737L6-6-2492-B0	40*15.2	2
79	Screw	50904-2-0015-F0	ST4x1.41x15L	2
80	Handle grip	26200-6-1584-B0	D30*3T*710L	1
81	Cross Bolt	52605-2-0010-N0	M5*0.8*10L	7
82	Lower computer cover	264A1-6-1703-B0	793*299*25.3	1
83	Middle computer cover	264A1-6-1711-B0	517.8*395*35	1
84	Computer	264A2-6-1701-B0	AC00521	1
85L	Left trigger	26200-6-1598-B0	53.3*46.9*14.7	1
85R	Right trigger	26200-6-1599-B0	53.3*46.9*14.7	1
86L	Sticker under left trigger	26200-6-1583-00	66.9*25.4	1
86R	Sticker under right trigger	26200-6-1593-00	66.9*25.4	1
87	Cross screw	52804-2-0012-F0	ST4*1.41*12L	18
88	Trigger base	26200-6-1579-01		2
89	Inner Hex Screw	54008-5-0016-UF0	M8*1.25*16L	4
90	Lower cable of trigger	264D2-6-1582-01	900L	2
91	Allen screw	54010-5-0045-F4	M10*1.5*45L	4
92	Allen bolt	50306-5-0015-UF0	M6*1*15L	4
93	Handpulse cable	261D8-6-1785-00	1000L	2
94	Buffer pedal pad	261D8-6-1061-RG0	200*43*37	4
95	Emergency stop pin	26100-6-1731-C1	21*18*1.5T	1
96	Safety key	26200-6-1732-R0	78.6*35*18.2	1
97	Safety clip	26200-6-1793-R0	830L	1
98	Cable for emergency stop function	261D8-6-1736-00	450L	1
99L	Right protecting plate	264A1-3-1130-B0		1
99R	Left protecting plate	264A1-3-1125-B0		1
100	Inner case of safety key	26100-6-1734-B0	39*15*13.3	2

101	Computer fixing plate	264A1-3-1530-J1		1
102	Safety key board	26200-6-1733-B0	74*45*7	1
103	Upper cover for handling tube	264A1-6-1576-B0	836*583*159.3	1
104	Lower cover for handling tube	264A1-6-1577-B0	836*356.8*193.7	1
105L	Side cover for handling tube(left)	264A1-6-1594-B0	417.2*153.3*78	1
105R	Side cover for handling tube(right)	264A1-6-1595-B0	417.2*153.3*78	1
106A	Computer back cover	264A1-6-1748-B0	207.3*188*65.5	1
106B	Computer decorative cover	264A1-6-1749-B0	188*49.2*20.5	1
107L	Left handlebar grips	264A1-6-1571-B0	448.7*126*71	1
107R	Right handlebar grips	264A1-6-1572-B0	448.7*126*71	1
108	Hollow plug	264A1-6-2010-B0	40x80x119	1
109	Flat washer	55105-1-1510-DA	D15*D5.2*1.0T	6
110	"Grounding cable 1	26100-6-1787-03	325L	1
111	"Grounding cable 2	264D2-6-1788-00	300L	1
112	live wire 1	261A2-6-1789-00	450L	1
113	live wire 2	26100-6-1790-01	60L	2
114	neutral wire 100L	26100-6-1791-00	100L	1
115	neutral wire 220L	26200-6-1792-00	220L	1
116	Magnetic loop	26100-6-1079-00	D31*16	1
117	Motor decorative cover	264A1-6-2403-Aa0	727.1*40.8*50.1	1
118	Upper cable of trigger	261D8-6-1589-02	550L	1
120	Upper computer cable	264A1-6-1771-00	850L	1
121	Middle computer cable	26200-6-1772-01	1000L	1
122	Lower computer cable	26200-6-1773-00	500L	1
123	Button plate	264A1-6-1756-B0	468*105.4*13.3	1
124	Filter	261D1-6-1067-00	15A	1
125	Inductance	261A2-6-1066-00	15A	1
126	Electric cable	26100-6-1775-02	1700L	1
127	Upper console cover	264D2-6-1702-B0	491*295.9*19	1
129	Allen cross spanner	58030-6-1051-N0	M6*130L	1
130	Allen spanner	58030-6-1052-N0	M8*120L	1
131	Speaker cover	264A1-6-1762-B0		2
132	USB module	261D8-6-1723-00	PA-AC00380-K2	1
133	CSK cross self-tapping screw	51004-2-0010-N0	ST4*1.41*10L	4

134	Cross round-head self-tapping screw	54723-2-0008-C0	ST2.3*8L	27
135	Button PCB board	264A1-6-1759-00		1
137	Inverter	262A3-6-1783-00	RM6T6-2003E1	1
138	neutral wire 450L	261A2-6-1791-00	450L	1
139	Pad of tablet support	264A1-6-1777-B0	409*15*2T	1
140	Cross tube of computer supporting tube	261D8-6-2001-J0	10*20*1.5T*320L	1
141	Cross bolt	52606-2-0015-F0	M6*1*15L	4
142	Allen bolt	50308-5-0015-F0	M8*1.25*15L	4
143	Spring washer	55108-2-1520-FA	D15.4xD8.2x2T	4
144	Left speaker	261D8-6-1722-01	B00202050,4Ω 3W,L300.	2
145	wireless heartrate receiver	261D8-6-1786-00	JW-WS809	1
146L	Left plug	264A1-6-1077-B0	D40.7*51.1	1
146R	Right plug	264A1-6-1078-B0	D40.7*51.1	1
147L	Left pad of bottle	264A1 -6-1754-B0	106.5*89.2*3T	1
147R	Right pad of bottle	264A1 -6-1755-B0	106.5*89.2*3T	1
148	module	261D2-6-1708-00	I-RUNNING	1
150	Nut	55208-2-2006-NA	M8*1.25*6T	1
151	Spacer	73800-6-3892-N0	D11.5*D8*3.5T	2
152	Adjustment round wheel	26200-6-1095-B0	D27*10L	2
153	Grounding cable (1)	26200-6-1787-00	330L	1
156	Upper cable of LED light	264A1-6-1739-00	L800	1
157	Middle cable of LED light	26200-6-1740-01	L1100	1
158	Lower cable of LED light	26200-6-1741-00	L600	1
159	LED light strap connecting plate	261D1-6-1744-00	PA-AA01170-K5	1
160	PC spacer column	261D1-6-1782-00	D5*D3.5*19.2	4
161	Light strap cable(1)	261D1-6-1742-00	L1000	2
162	Light strap	261D1-6-1737-00	LED7 color strip 135CM	2
163	Round cross screw	50805-2-0010-N0	M5x0.8x10L	4
168	Elastic rope	264A1-6-2098-B1	D2.5*500L	1
169	Fixing hook	26502-6-2097-B0	37.8*100*20.6	1
170	Pad holder	26500-6-1713-B0	271.8*25*20	1
171	Pad holder support	26500-6-1766-B0	271.9*29.8*20.1	1
172	Disc head cross tapping screws	53335-2-0013-N0	ST3.5*13L	3
173	Buffer strips	264A1-6-1084-B0	255*10*2T	1

Products from TAURUS® are subject to strict quality control. However, if a fitness equipment purchased from us does not work perfectly, we take it very seriously and ask you to contact our customer service as indicated. We are happy to help you by phone via our service hotline.

Error Descriptions

Your fitness equipment is developed for long-term, high-quality training. However, should a problem arise, please first read the operating instructions. For further assistance, please contact your contract partner or call our service hotline. To ensure your problem is solved as quickly as possible, please describe the defect as exactly as possible.

In addition to the statutory warranty, we provide a warranty for every fitness equipment purchased from us according to the following provisions.

Your statutory rights are not affected.

Warranty

The warranty is the first/original buyer.

Warranty periods

The following warranty periods begin on delivery of the fitness equipment.

Warranty period

The warranty periods, shown on our web shop, begin on delivery of the fitness equipment. The respective warranty periods for your equipment can be found on its product website.

Repair Costs

According to our choice, there will either be a repair, a replacement of individual damaged parts or a complete replacement. Spare parts, that have to be mounted while assembling the equipment, have to be replaced by the warranty holder personally and are not a part of repair. After the expiration of the warranty period, the responsibility for parts costs, repair costs, installation costs and delivery costs lies with the warranty holder.

The terms of use are defined as follows:

- + Home use: solely for private use in private households up to 3 hours per day
- + Semi-professional use: up to 6 hours per day (e. g. rehabilitation centres, hotels, clubs, company gyms)
- + Professional use: more than 6 hours per day (e. g. commercial gyms)

Warranty Service

Within the warranty period, equipment which develops faults as a result of material or manufacturing defects, will be repaired or replaced at our discretion. Ownership of equipment or parts of equipment which have been replaced is transferred to us. The warranty period is not extended nor does a new warranty period begin following repair or replacement under the warranty.

Warranty Conditions

For the warranty to be valid, the following steps must be taken:

Please contact our customer service by email or phone. If the product under warranty has to be sent in for repair, the seller bears costs. After expiry of the warranty, the buyer bears the costs of transport and insurance. If the fault is covered by our warranty, you will receive a new or repaired equipment in return.

Warranty claims are invalid in case of damage resulting from:

- + misuse or improper handling
- + environmental influences (moisture, heat, electrical surge, dust, etc.)
- + failure to follow the current safety measures for the equipment
- + failure to follow the operating instructions
- + use of force (e. g. hitting, kicking, falling)
- + interventions which were not carried out by one of our authorized service centres
- + unauthorised repair attempts

Proof of Purchase and Serial Number

Please make sure that you are able to provide the appropriate receipt when claiming on your warranty. So that we can clearly identify the model of your equipment, and for the purposes of our quality control, you will need to give the serial number of your equipment, when contacting the service team. Where possible please have your serial number and your customer number ready when you call our service hotline. It will help us to deal with your request swiftly.

If you cannot find the serial number on your fitness equipment, our service team is at your disposal to offer further information.

Service outside of the Warranty Period

We are also happy to issue an individual cost estimate if there is a problem with your fitness equipment after the warranty has expired, or in cases which do not fall under the terms of the warranty, e. g. normal wear and tear. Please contact our customer service team to find a quick and cost-effective solution to your problem. In such a case you will be responsible for the delivery costs.

Communication

Many problems can be solved just by speaking to us as your specialist supplier. We know how important it is to you as a user of the fitness equipment to have problems solved quickly and simply, so you can enjoy working out with minimal interruption. For that reason, we also want to resolve your queries quickly and in a straightforward manner. Thus, please always keep your customer number and the serial number of the faulty equipment handy.

10 CONTACT

DE	DK	UK
<p>TECHNIK</p> <p>☎ +49 4621 4210-900 ☎ +49 4621 4210-698 ✉ technik@fitshop.de 🕒 Öffnungszeiten entnehmen Sie unserer Homepage.</p> <p>SERVICE</p> <p>☎ 0800 20 20277 (kostenlos) ☎ 04621 4210 - 0 ✉ info@fitshop.de 🕒 Öffnungszeiten entnehmen Sie unserer Homepage: https://stg.fit/statita</p>	<p>TEKNIK OG SERVICE</p> <p>☎ 80 90 16 50 ☎ +49 4621 4210-945 ✉ info@fitshop.dk 🕒 Åbningstider kan findes på hjemmesiden: https://stg.fit/statit7</p>	<p>CUSTOMER CARE</p> <p>☎ +44 141 737 2249 or ☎ +44 141 876 3972 ✉ customercare@fitshop.co.uk 🕒 You can find the opening hours on our homepage: https://stg.fit/statit8</p>
	FR	BE
	<p>TECHNIQUE & SERVICE</p> <p>☎ +33 (0) 189 530984 ☎ +49 4621 42 10 933 ✉ info@fitshop.fr 🕒 Vous trouverez les heures d'ouverture sur notre site Internet: https://stg.fit/statit4</p>	<p>TECHNIQUE & SERVICE</p> <p>☎ 02 732 46 77 ☎ +49 4621 4210 933 ✉ info@fitshop.be 🕒 Vous trouverez les heures d'ouverture sur notre site Internet: https://stg.fit/statit8</p>
ES	NL	INT
<p>TECNOLOGÍA Y SERVICIOS</p> <p>☎ 911 238 029 ✉ info@fitshop.es 🕒 Consulta nuestro horario de apertura en la página web: https://stg.fit/statit5</p>	<p>TECHNISCHE DIENST & SERVICE</p> <p>☎ +31 172 619961 ✉ service@fitshop.nl 🕒 De openingstijden vindt u op onze homepage: https://stg.fit/statit3</p>	<p>TECHNICAL SUPPORT & SERVICE</p> <p>☎ +49 4621 4210-944 ✉ service-int@fitshop.de 🕒 You can find the opening hours on our homepage: https://stg.fit/statita</p>
PL	AT	CH
<p>DZIAŁ TECHNICZNY I SERWIS</p> <p>☎ 22 307 43 21 ☎ +49 4621 42 10-948 ✉ info@fitshop.pl 🕒 Godziny otwarcia można znaleźć na stronie głównej: https://stg.fit/statit6</p>	<p>TECHNIK & SERVICE</p> <p>☎ 0800 20 20277 (Freecall) ☎ +49 4621 42 10-0 ✉ info@fitshop.at 🕒 Öffnungszeiten entnehmen Sie unserer Homepage: https://stg.fit/statitb</p>	<p>TECHNIK & SERVICE</p> <p>☎ 0800 202 027 ☎ +49 4621 42 10-0 ✉ info@fitshop.ch 🕒 Öffnungszeiten entnehmen Sie unserer Homepage: https://stg.fit/statit9</p>

Please find a detailed overview including address and opening hours for all stores of Fitshop UK on the following website:

www.fitshop.co.uk/storelocator

WE LIVE FITNESS

WEBSHOP AND SOCIAL MEDIA

The Fitshop Group is Europe's largest specialist for home fitness equipment with currently 70 stores and one of the world's most renowned online mail order companies for fitness equipment.

Fitshop UK is part of the Fitshop Group. Private customers order via the 25 web shops in the respective national language or have their desired equipment assembled on site. In addition, the company supplies fitness studios, hotels, sports clubs, companies and physio practices with professional equipment for endurance and strength training.

The Fitshop group offers a wide range of fitness equipment from renowned manufacturers, high-quality in-house developments and comprehensive services, such as a build-up service and sports scientific advice before and after the purchase. The company employs numerous sports scientists, fitness trainers and competitive athletes.

Visit us also on our social media platforms or our blog!

	https://www.fitshop.co.uk www.fitshop.co.uk/blog
	www.facebook.com/fitshop.co.uk
	www.instagram.com/fitshop_uk
	www.youtube.com/@fitshop_uk

TAURUS

 cardiostrong

BODYCRAFT

BodyMax

Notes

Notes

Notes

TAURUS®

Treadmill T10.3 Pro