

TAURUS®

Assembly and Operating Instructions

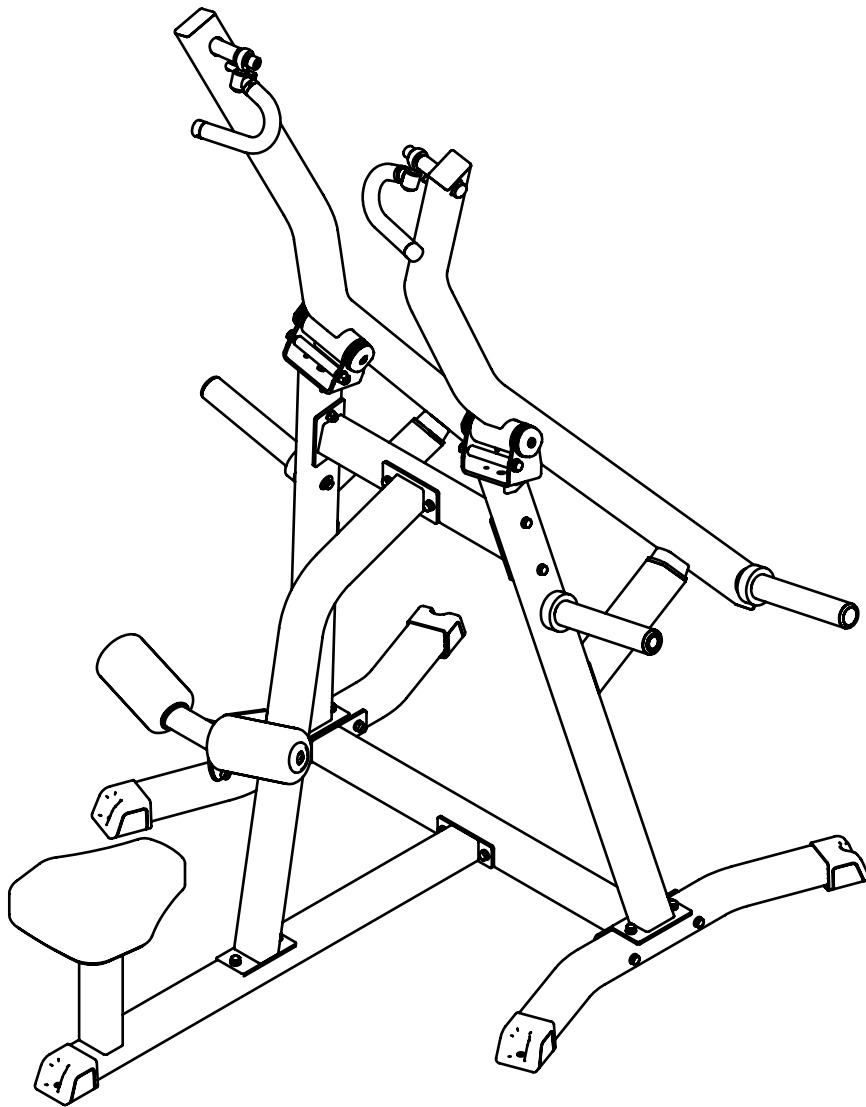

max. 150 kg



~ 120 Min.



95 kg

L 170 | W 134 | H 205

SESS716001.01

SKU: SESS7160

Taurus Pro Lat Pulldown

Content

1	GENERAL INFORMATION	7
1.1	Technical Data	7
1.2	Personal Safety	8
1.3	Set-Up Place	9
2	ASSEMBLY	10
2.1	General Instructions	10
2.2	Scope of Delivery	10
2.3	Assembly	12
3	STORAGE AND TRANSPORT	19
3.1	General Instructions	19
4	TROUBLESHOOTING, CARE AND MAINTENANCE	20
4.1	General Instructions	20
4.2	Faults and Fault Diagnosis	20
4.3	Maintenance and Inspection Calendar	21
5	DISPOSAL	21
6	RECOMMENDED ACCESSORIES	22
7	ORDERING SPARE PARTS	23
7.1	Serial Number and Model Name	23
7.2	Parts List	24
7.3	Exploded Drawing	28
8	WARRANTY	33
9	CONTACT	35

Dear customer,

Thank you for choosing a high-quality equipment of the brand Taurus®. Taurus® offers sports and fitness equipment for the sophisticated home sport and the equipment of fitness studios and business customers. With Taurus® fitness equipment, the focus is on what sport is all about: maximum performance! Therefore, the equipment is developed in close consultation with athletes and sports scientists. Because athletes know best what makes perfect fitness equipment.

Further information can be found at www.sport-tiedje.com.

Intended Use

The equipment may only be used for its intended purpose.

The equipment is suitable for home use and semi-professional use (e.g. hospitals, clubs, hotels, schools, etc.). The equipment is not suitable for commercial or professional use (e.g. fitness studio).

Disclaimer

©2011 Taurus® is a registered brand of the company Sport-Tiedje GmbH. All rights reserved. Any use of this trademark without the explicit written permission of Sport-Tiedje is prohibited.

Product and manual are subject to change. Technical data can be changed without advance notice.

ABOUT THIS MANUAL

Please carefully read the entire manual before installation and first use. The manual will help you to quickly set up the system and explains how to safely use it. Make sure that all persons exercising with the equipment (especially children and persons with physical, sensory, mental or motor disabilities) are informed about this manual and its contents in advance. In case of doubt, responsible persons must supervise the use of the equipment.

Due to ongoing changes and software optimisations, the manual may have to be updated. If you notice any discrepancies during assembly or use, please refer to the manual uploaded to the webshop. The latest manual is always available there.

This equipment has been manufactured according to the latest safety knowledge. As far as possible, potential safety hazards which could cause injury have been eliminated. Make sure to carefully follow the instructions and that all parts are securely in place. If required, read through the instructions again to correct any mistakes.



Please pay close attention to the safety and maintenance instructions given here. The contract partner cannot be held liable for damage to health, accidents or damage to the equipment when it is not used in accordance with these instructions.

Box 1:

The following safety instructions may appear in this manual:

► **ATTENTION**

This notice indicates potentially hazardous situations which, if not avoided, may result in property damage.

⚠ **CAUTION**

This notice indicates potentially hazardous situations which, if not avoided, may result in slight or minor injuries!

⚠ **WARNING**

This notice indicates potentially hazardous situations which, if not avoided, may result in death or serious injuries!

⚠ **DANGER**

This notice indicates potentially hazardous situations which, if not avoided, will result in death or serious injuries!

ⓘ **NOTICE**

This notice indicates further useful information.

Retain these instructions in a safe place for future reference, maintenance or when ordering replacement parts.

1.1 Technical Data

Weight and Dimensions

Article weight (gross, incl. packaging) approx.:

Box 1:

59 kg

Box 2:

46.5 kg

Article weight (net, excl. packaging) approx.:

95 kg

Packaging dimensions (L x W x H) approx.:

Box 1:

133.5 cm x 50.5 cm x 34 cm

Box 2:

173.5 cm x 51.5 cm x 23 cm

Set-up dimensions (L x W x H) approx.:

170.3 cm x 139.9 cm x 204.7 cm

Maximum user weight:

150 kg

Maximum load:

200 kg

Class:

S

1.2 Personal Safety

DANGER

- + Before you start using the equipment, you should consult your physician that this type of exercise is suitable for you from a health perspective. Particularly affected are persons who: have a hereditary disposition to high blood pressure or heart disease, are over the age of 45, smoke, have high cholesterol values, are overweight and/or have not exercised regularly in the past year. If you are under medical treatment that affects your heart rate, medical advice is absolutely essential.
- + Note that excessive training can seriously endanger your health. Please also note that heart rate monitoring systems can be inaccurate. If you notice any signs of weakness, nausea, dizziness, pain, shortness of breath, or other abnormal symptoms, stop exercising immediately and seek advice from your doctor if necessary.
- + The owner must communicate all warnings and instructions to the user.

WARNING

- + This equipment may not be used by children under the age of 14.
- + Children should not be allowed unsupervised access to the equipment.
- + Persons with disabilities must have a medical license and must be under strict observation when using the equipment.
- + The equipment is strictly for use by one person at a time.
- + If your equipment provides a safety key, the clip of the safety key must be attached to your clothing before starting your training. In the event of a fall, the EMERGENCY STOP of the equipment can be initiated.
- + Keep your hands, feet and other body parts, hair, clothing, jewellery and other objects well clear of moving parts.
- + During use, wear suitable sports clothing rather than loose or baggy clothing. When wearing sports shoes, make sure they have suitable soles, preferably made of rubber or other non-slip materials. Shoes with heels, leather soles, studs or spikes are unsuitable. Never exercise barefoot.
- + Always start each workout with a light warm-up and end with a cool-down phase.
- + Using the machine as a support during stretching exercises or attaching resistance bands, ropes or other accessories to it, may cause injuries.

CAUTION

- + If your equipment needs to be connected to the power supply with a mains cable, make sure that the cable is not a potential tripping hazard.
- + Make sure that nobody is within the range of motion of the equipment during training so as not to endanger you or other persons.
- + Be aware that if adjustment devices are left protruding, they may impede the user's movement.

ATTENTION

- + Do not insert any objects of any kind into the openings of the device.

1.3 Set-Up Place

⚠ WARNING

- + Do not place the equipment in main corridors or escape routes.

⚠ CAUTION

- + Choose a location in which to place the equipment such that there is enough free space/clearance to the front, the rear and to the sides of the equipment.
- + The training room should be well ventilated during training and not be exposed to any draughts.
- + Choose the place in which to set up the equipment such that there is enough free space/clearance to the front, the rear and to the sides of the equipment.
- + The free area in the direction from which the exercise equipment is accessed must be at least 0.6 m larger than the exercise area.
- + The set-up and mounting surface of the equipment should be flat, loadable and solid.
- + If your device is to be mounted on the wall/ceiling, make sure that you use the appropriate assembly material to avoid possible damages or personal injuries. The contractual partner accepts no liability for this.

▶ ATTENTION

- + The device may only be used in one building, in sufficiently tempered and dry rooms (ambient temperatures between 10°C and 35°C). The equipment should not be used outdoors or in rooms with high humidity (over 70%) like swimming pools.
- + A floor protective mat/equipment underlay can help to protect high-quality floor coverings (parquet, laminate, cork, carpets) from dents and sweat and can help to level out slight unevenness.
- + For Class S and I equipment, the exercise equipment may only be used in areas where access, supervision and control are specifically regulated by the owner.

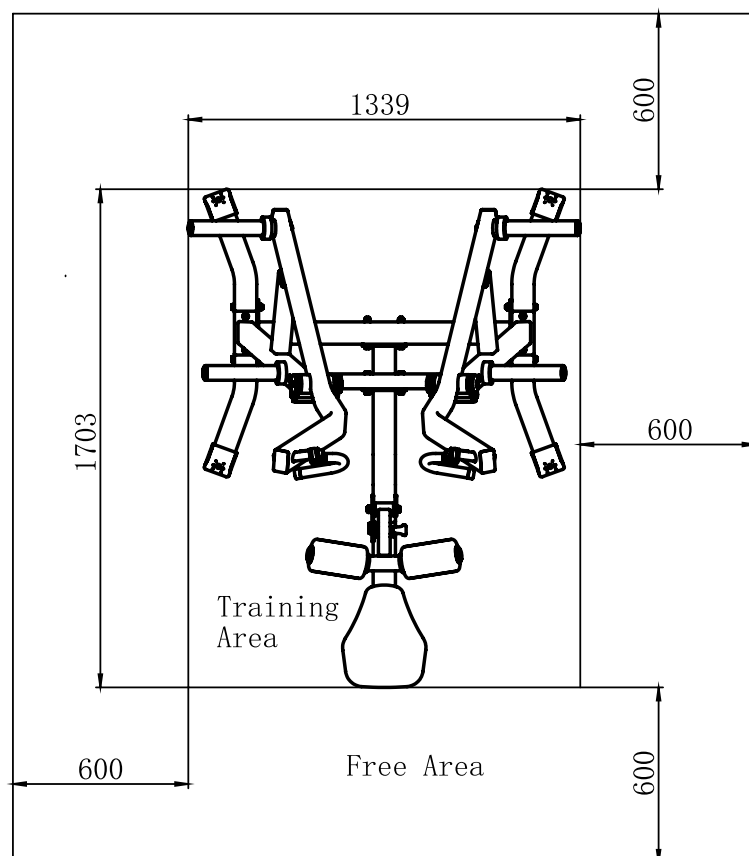

2.1 General Instructions

DANGER

- + Do not leave any tools, packaging materials such as foils or small parts lying around, as otherwise there is a danger of suffocation for children. Keep children away from the equipment during assembly.

WARNING

- + Pay attention to the instructions attached to the equipment in order to reduce the risk of injuries.

CAUTION

- + Ensure to have sufficient room for movement in each direction during assembly.
- + The assembly of the equipment must be carried out by at least two adults. If in doubt, seek the help of a third technically skilled person.

ATTENTION

- + To prevent damage to the equipment and the floor, assemble the equipment on a mat or packaging board.

NOTICE

- + In order to make the assembly as simple as possible, some screws and nuts to be used can already be pre-assembled.
- + Ideally, assemble the equipment at its later set-up place.

2.2 Scope of Delivery

The scope of delivery consist of the following parts. At the beginning, check whether all parts and tools belonging to the device are included in the scope of delivery and whether damage has occurred. In the event of complaints, the contractual partner must be contacted directly.

CAUTION

- If parts of the scope of delivery are missing or damaged, the assembly must not be carried out.

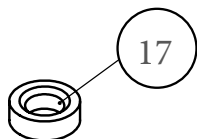
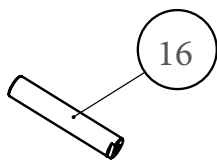
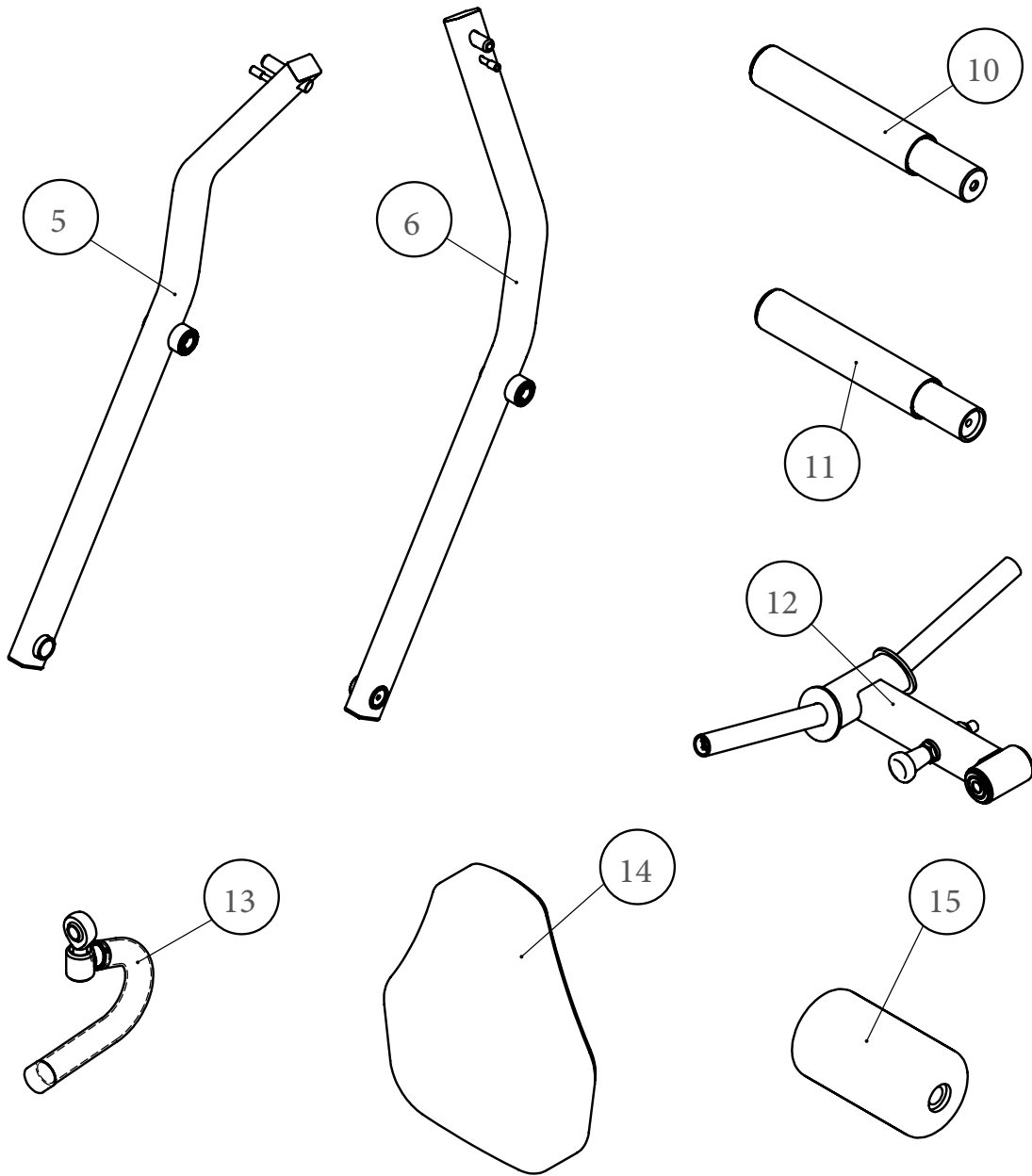

Item No.	Description	Quantity
5	Left Arm Frame ASSY	1
6	Right Arm Frame ASSY	1
10	Weight Horn ASSY	2
11	Weight Plate Storage ASSY	2
12	Foam Frame ASSY	1
13	Handle Frame ASSY	2
14	Seat Pad	1
15	Foam Pad	2
16	Pivot Shaft Ø25	2
17	Weight Horn Rubber Donut	4
	Hardware Pack	
	Manual	

2.3 Assembly

Before assembly, take a close look at the individual assembly steps shown and carry out the assembly in the order given.

① NOTICE

- + First loosely screw all parts together and check that they fit properly. Tighten the screws using the tool only when you are instructed to do so.
- + If you have difficulty recognising the graphics, we recommend that you open and/or download the PDF instructions stored in the webshop on your end device (e.g. smartphone, tablet or PC). There you have the option of zooming in closer.
- + For better readability, the addition "ASSY" to the name of some assembly components has been omitted in the assembly instructions. The abbreviation refers to components that consist of more than one component but have been pre-assembled by factory. Please note that the abbreviation is used in the parts lists and exploded drawings as it may be relevant for ordering spare parts.

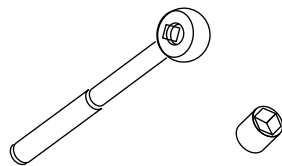

Ratchet Wrench and Socket

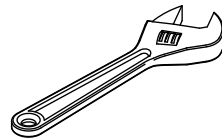

Adjustable Wrench

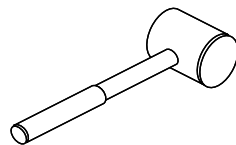

Rubber Mallet



Hex Key Wrench Set

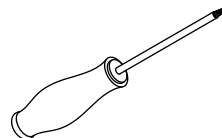

Phillips Screwdriver

Step 1: Assembly of the Main Frame Parts, Part 1

① NOTICE

Do not tighten screws, bolts and nuts completely yet. Leave room for adjustments.

1. Attach the two base frames (1) and the lat seat frame (3) to the bottom crossmember (2) using six M10*100 bolts (25), twelve Ø11*Ø20*2 flat washers (32) and six M10 lock nuts (36)
2. Tighten the bolts and nuts with the appropriate tools.

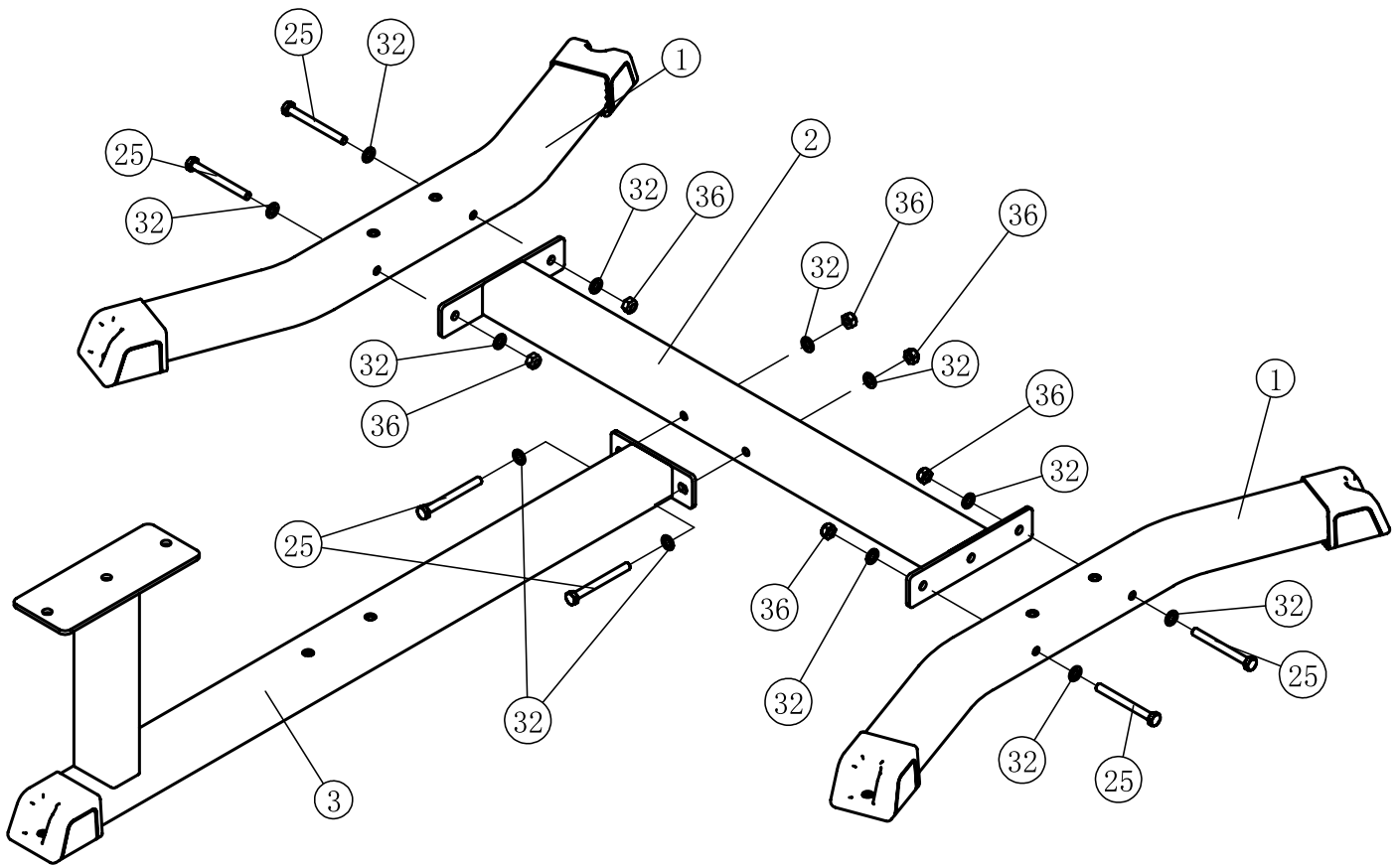

Step 2: Assembly of the Main Frame Parts, Part 2

1. Attach the left frame (7) and the right frame (8) to the two base frames (1) using four M10*30 bolts (27), four Ø10 spring washers (34) and four Ø11*Ø20*2 flat washers (32).
2. Attach the top crossmember (9) to the left frame (7) and the right frame (8) using four M10*75 bolts (26), eight Ø11*Ø20*2 flat washers (32) and four M10 lock nuts (36).
3. Attach the upright frame (4) to the lat seat frame (3) and the crossmember (9) using four M10*30 bolts (27), four Ø10 spring washers (34) and four Ø11*Ø20*2 flat washers (32).
4. Tighten the bolts and nuts with the appropriate tools.

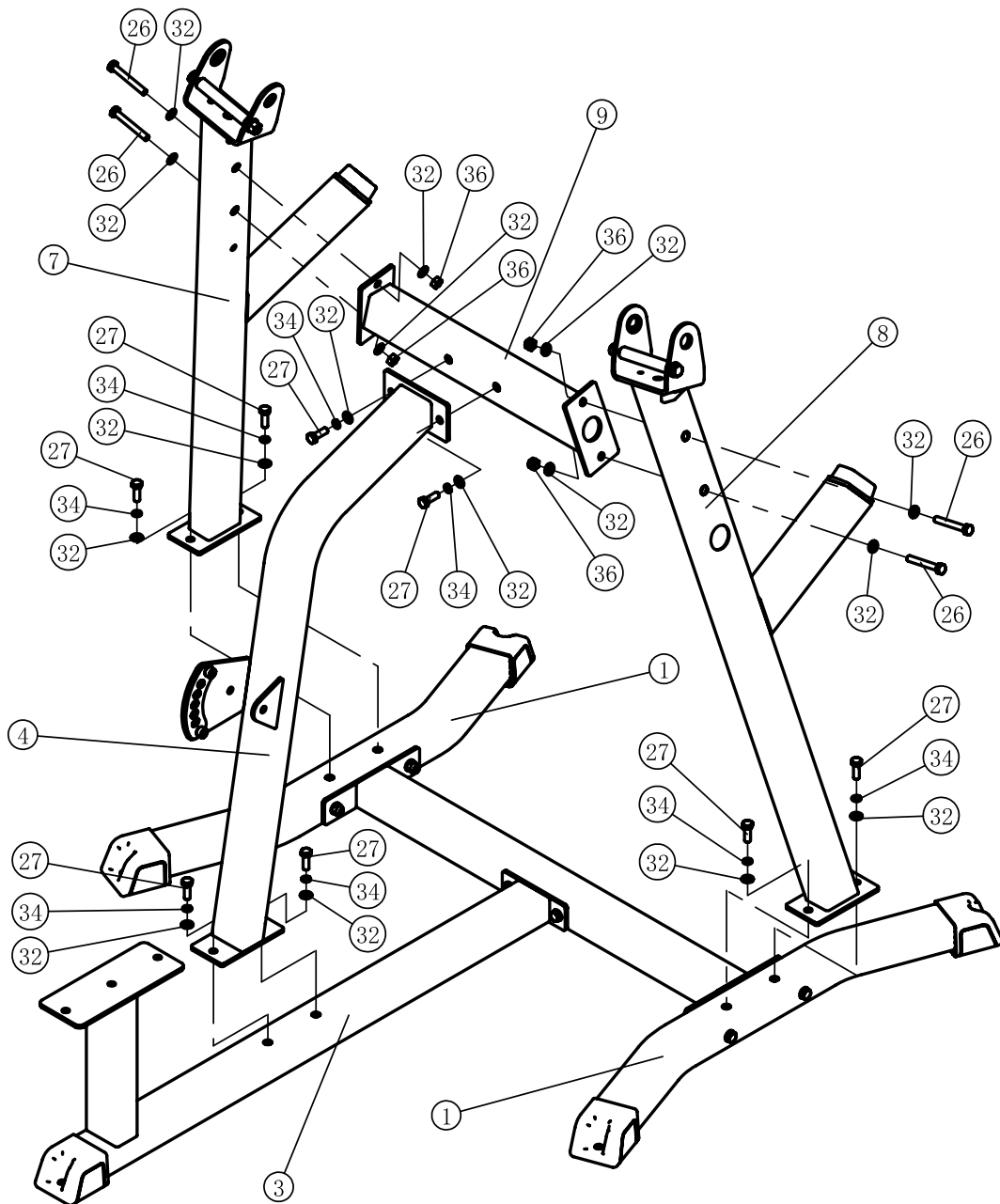

Step 3: Assembly of the Arm Frames and Handle Frames

1. Attach the left arm frame (5) to the left frame (7) and the right arm frame (6) to the right frame (8) using two pivot shafts $\text{Ø}25$ (16), four $\text{Ø}62 \times \text{Ø}10.5 \times 3$ washers (18), four $\text{Ø}62.5 \times 5$ circle rings (20), four $\text{Ø}60$ caps and four M10*30 screws (28).
2. Attach the two handle frames (13) to the left arm frame (5) and the right arm frame (6) using two M16*45 screws (23) and two $\text{Ø}16$ spring washers (33).
3. Tighten the screws, bolts and nuts with the appropriate tools.

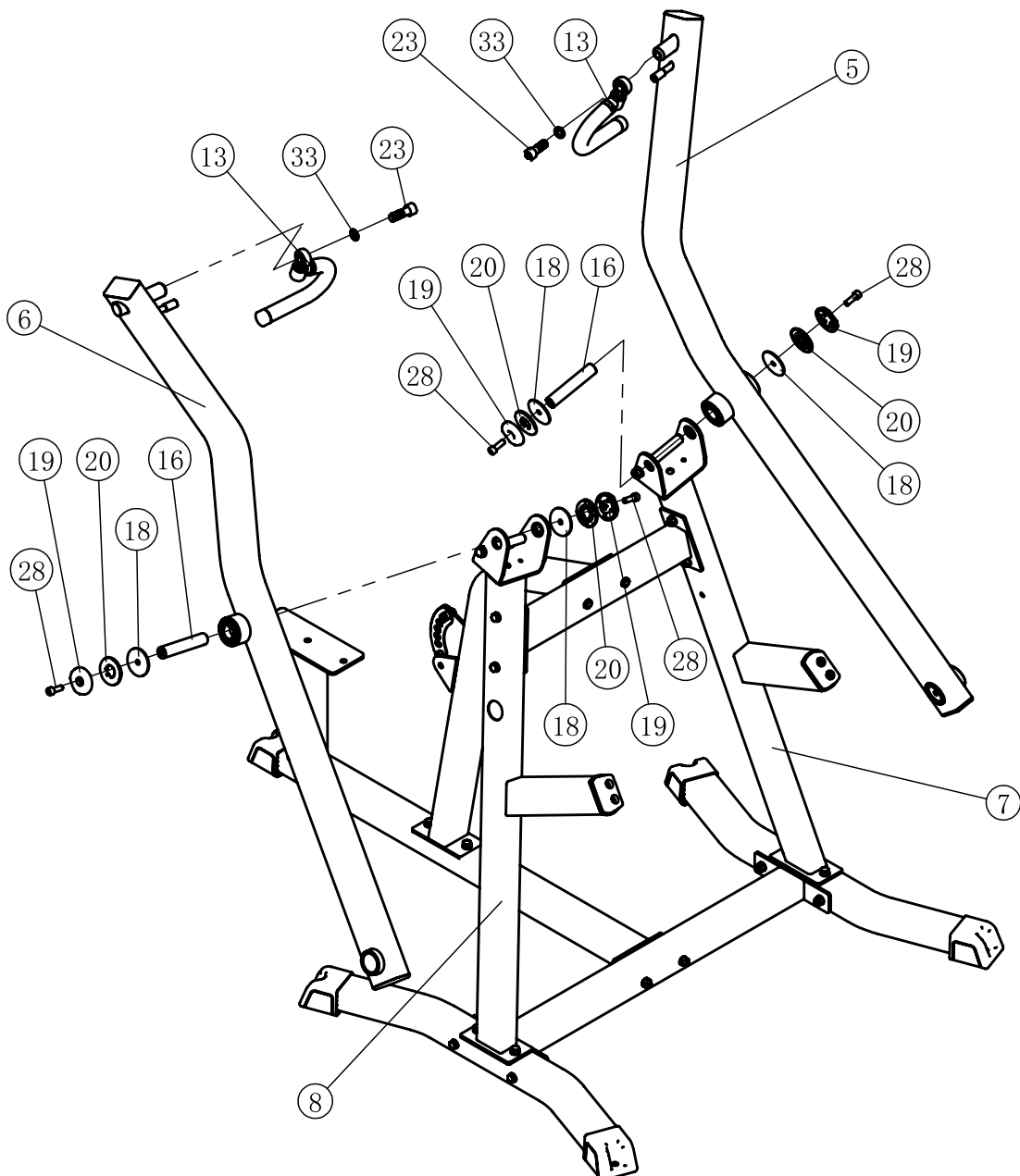

Step 4: Assembly of the Weight Horns, Weight Plate Storages and Foam Frame

1. Loosen the two M8*6 screws and then attach the two weight horns (10) and two weight horn rubber donuts (17) to the left arm frame (5) and the right arm frame (6) using two M10*30 bolts (27), two $\text{\O}11*\text{\O}20*2$ flat washers (32) and two $\text{\O}10$ spring washers (34).
2. Attach the two weight plate storages (11) and two weight horn rubber donuts (17) to the left frame (7) and the right frame (8) using two M10*30 bolts (27), two $\text{\O}11*\text{\O}30*2$ flat washers (31) and two $\text{\O}10$ spring washers (34).
3. Attach the foam frame (12) to the upright frame (4) using one M12*105 bolt (24), two $\text{\O}13*\text{\O}24*2.5$ flat washers (30) and one lock nut (35).
4. Tighten the bolts and nuts with the appropriate tools.

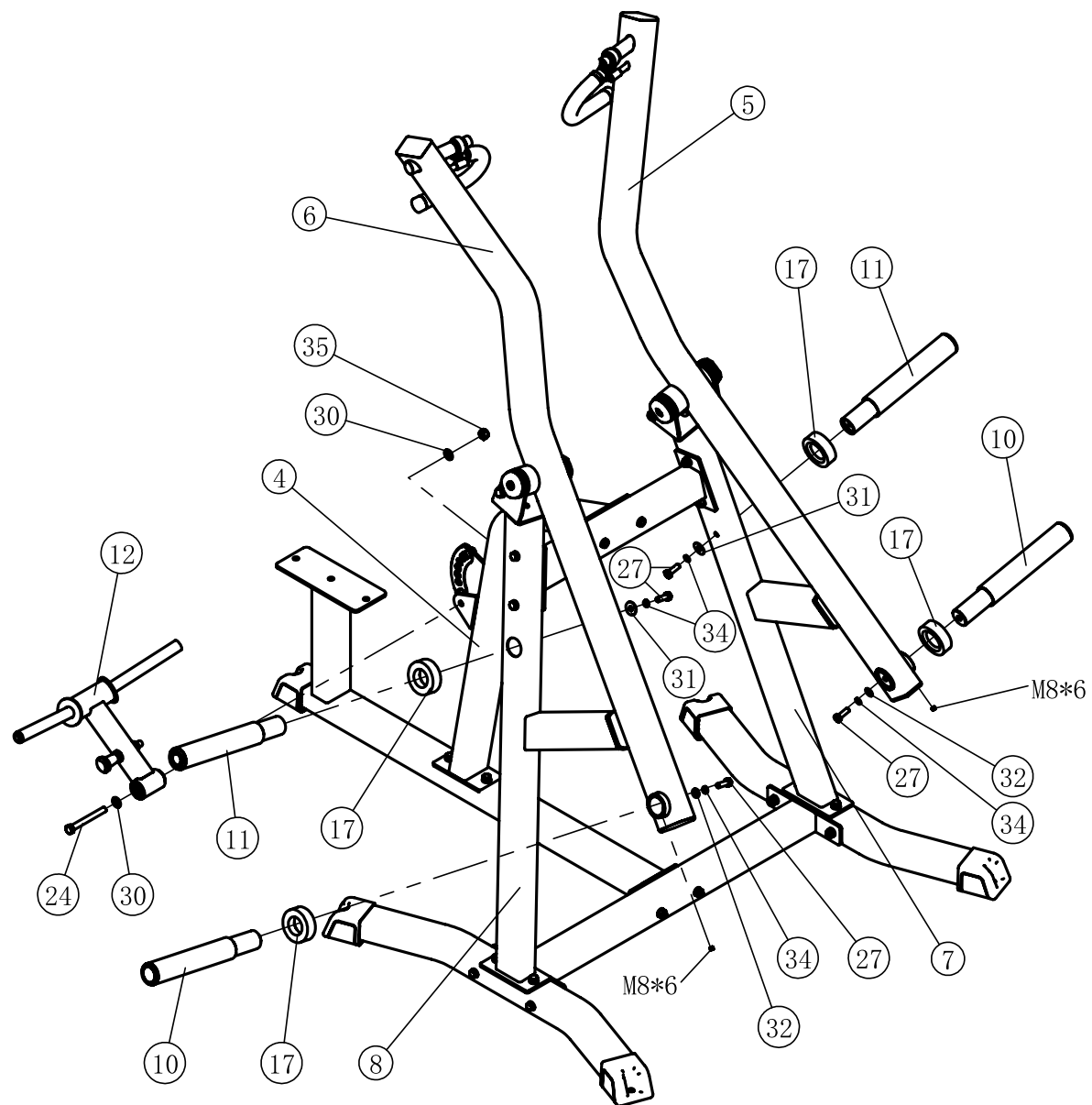

Step 5: Assembly of the Foam Pads and Seat Pad

1. Attach the two foam pads (15) to the foam frame (12) using two M10*30 screws (29), two Ø11*Ø20*2 flat washers (32), four plastic washers (22) and two end caps (21).
2. Attach the seat pad (14) to the lat seat frame (3) using two M10*30 bolts (27) and two Ø11*Ø20*2 flat washers (32).
3. Tighten the screws and bolts with the appropriate tools.



CAUTION

The equipment must be anchored to the floor to prevent movement and increase stability.

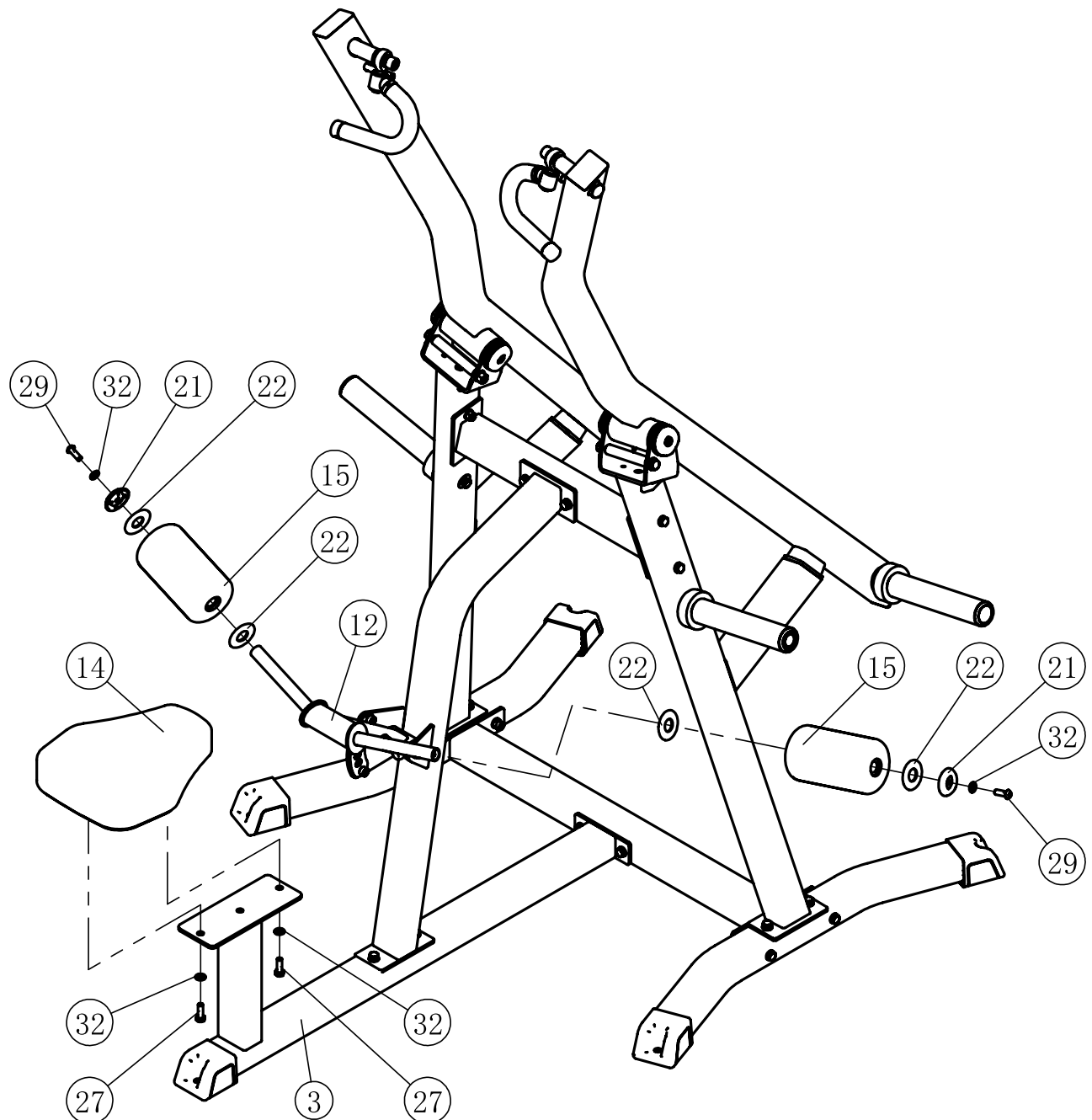

Load and Unload Weight Plates

CAUTION

- + Make sure to always use some sort of weight collar when exercising with external weights.
 - + Never store unused weight plates on the floor.
 - + Store unused weight plates on a weight rack.
1. To load the weight horn, carefully grab one weight plate at a time with both hands.
 2. Slide each weight plate onto the weight horn one by one until you have reached your desired training weight.
 3. Attach a weight collar to secure the weight plates from sliding off.
 4. To unload the weight horn, take off the weight collar.
 5. Slide each weight plate off of the weight horn with both hands one by one.

Foam Pad Adjustment

1. Pull the spring pin and adjust the Foam Pad to the desired position.
2. Make sure the spring pin engages audibly into the adjustment hole completely.

Adjust & Exercise Instruction

NOTICE

- + The weight horns are compatible with 50 mm weight plates and a maximum external diameter of 450 mm.
 - + Weight plates and weight collars are not included in the scope of delivery.
 - + Do not load more than 100 kg on the weight horn.
1. Add your desired amount of weight plates to the weight horns.
 2. Sit on the seat pad and adjust the foam pad to the desired position.
 3. Pull the handles straight down.
 4. Pause slightly and then slowly return to the starting position.

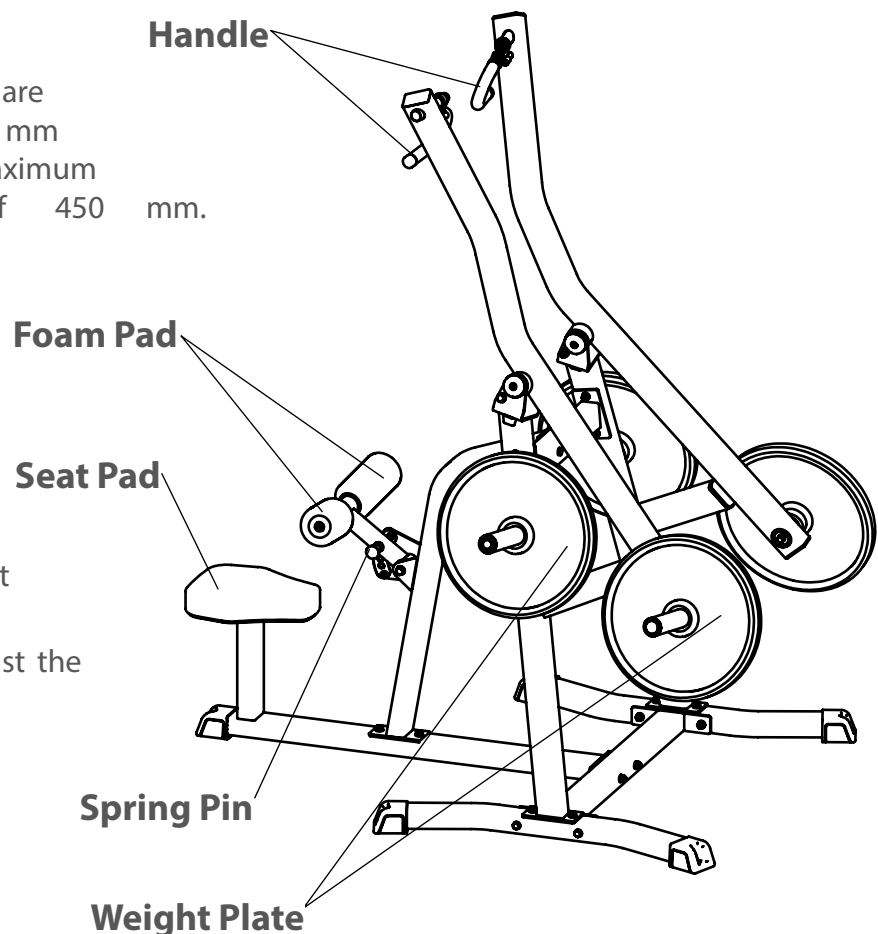

3.1 General Instructions

 **WARNING**

- + The storage location should be chosen so that improper use by third parties or children can be prevented.
- + If your equipment does not have transportation wheels, the equipment must be disassembled before transportation.

 **ATTENTION**

- + Make sure that the equipment is protected from moisture, dust and dirt in the selected storage location. The storage location should be dry and well ventilated and have a constant ambient temperature between 10°C and 35°C.

4.1 General Instructions

WARNING

- + Do not make any improper changes to the equipment.

CAUTION

- + Damaged or worn components may affect your safety and the life of the equipment. Safety can only be guaranteed if you check the equipment regularly for wear and damage. Replace damaged or worn components immediately. In such a case, contact the contract partner. The equipment must not be used until it has been repaired. If necessary, use only original spare parts.

ATTENTION

- + In addition to the instructions and recommendations for maintenance and care given here, additional service and/or repair work may be necessary; this must only be carried out by authorised service technicians.

4.2 Faults and Fault Diagnosis

The equipment undergoes regular quality controls during production. Nevertheless, faults or malfunctions may occur. Frequently, individual parts are responsible for these disturbances, an exchange is usually sufficient. Please refer to the following overview for the most common errors and how to correct them. If the equipment still does not function properly, contact your contract partner.

Fault	Cause	Solution
Squeaking & cracking noises	Screw connections loosened or too tight	+ Check or lubricate screw connections*
Unit wobbles	+ Uneven ground + Loose screw connections	+ Align unit + Tighten screw connections

* With a grease-free silicone oil or silicone spray.

4.3 Maintenance and Inspection Calendar

To avoid damage from body sweat, the equipment must be cleaned with a damp towel (no solvents!) after each training session.

The following routine tasks must be performed at the specified intervals:

Part	Weekly	Monthly	Quarterly
Screw connections		I	
Cushions	C		
Legend: C = clean; I = inspect			

5 DISPOSAL

At the end of its operational life, this equipment cannot be disposed of in normal household waste. Instead, it must be disposed of via an recycling centre. Further information can be obtained from your local authority's recycling service.

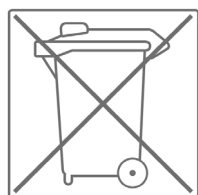

The materials can be recycled as per their symbols. Through the reuse, recycling of materials or other forms of recovery of old equipment, you make an important contribution to the protection of the environment.

6 RECOMMENDED ACCESSORIES

To make your training experience even more efficient and pleasant, we recommend that you add suiting accessories to your fitness equipment. For training equipment like smith machines, weight benches or racks this could for example be a **floor mat**, which makes your fitness equipment stand more securely and also protects the floor from sweat but it could be also **additional weights, handles, foot straps** for leg exercises or **triceps ropes**. For some smith machines, there are also optional add-ons such as **leg presses** that make your workout even more intense and comprehensive.

Our range of accessories offers the highest quality and makes training even better. If you would like to find out more about compatible accessories, please go to the detail page of the product in our webshop (the easiest way is to enter the article number in the search field above) and go to the recommended accessories on this page. Of course, you can also contact our customer service: by telephone, e-mail, in one of our branches or via our social media channels. We will be happy to advise you!



floor mat



chest strap



tricep and curl bar



triceps rope

7.1 Serial Number and Model Name

In order to provide you with the best possible service, please have the model name, article number, serial number, exploded drawing and parts list ready. The corresponding contact options can be found in chapter 9 of this operating manual.

NOTICE

The serial number of your equipment is unique. It's located on a white sticker. The exact position of this sticker is shown in the following illustration.

Enter the serial number in the appropriate field.

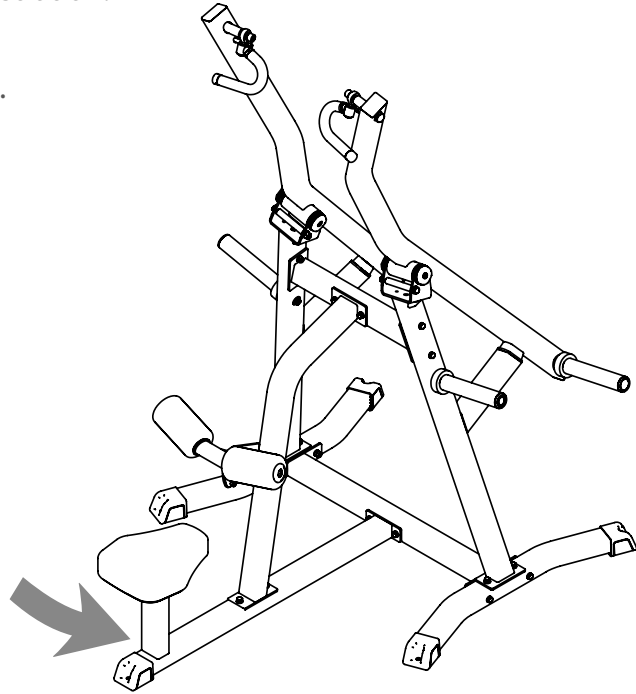

Serial number:

Brand / Category:

Taurus / multi gym

Model Name:

Taurus Pro Lat Pulldown

SKU:

SESS7160

7.2 Parts List

Item No.	Part No.	Description	Qty.
1	IFP130101ASSY	Base Frame ASSY	2
2	IFP13010200	Bottom Crossmember	1
3	IFP130103ASSY	Lat Seat Frame ASSY	1
4	IFP130104ASSY	Upright Frame ASSY	1
5	IFP130105ASSY	Left Arm Frame ASSY	1
6	IFP130106ASSY	Right Arm Frame ASSY	1
7	IFP130107ASSY	Left Frame ASSY	1
8	IFP130108ASSY	Right Frame ASSY	1
9	IFP13010900	Top Crossmember	1
10	IFP130110ASSY	Weight Horn ASSY	2
11	IFP161316ASSY	Weight Plate Storage ASSY	2
12	IF930208ASSY	Foam Frame ASSY	1
13	IFP130113ASSY	Handle Frame ASSY	2
14	IF93015200V2	Seat Pad	1
15	IF81023500V6	Foam Pad	2
16	IF93012600	Pivot Shaft $\Phi 25$	2
17	HF985A1500	Weight Horn Rubber Donut	4
18	IF93062200	Washer $\Phi 62 \times \Phi 10.5 \times 3$	4
19	FE97211900	Cap $\Phi 60$	4
20	FE97212000	Circle Ring $\Phi 62.5 \times 5$	4
21	IF81022000PBC	End Cap	2
22	HF1652100	Plastic Washer	4
23	GB70M16*45DHS20	Socket Head Cap Screw M16*45	2
24	GB5780M12*105DHS20	Hex Head Bolt M12*105	1
25	GB5780M10*100DHS20	Hex Head Bolt M10*100	6
26	GB5780M10*75DHS20	Hex Head Bolt M10*75	4
27	GB5781M10*30DHS20	Hex Head Bolt M10*30	14
28	GB70M10*30DHS20NL	Socket Head Cap Screw M10*30	4
29	PNLM10*30*30DHS20NL	Button Head Cap Screw M10*30	2
30	GB9512DHS2	Flat Washer $\Phi 13 \times \Phi 24 \times 2.5$	2
31	DQ10DHS2C	Flat Washer $\Phi 11 \times \Phi 30 \times 2$	2

32	GB9510DHS2	Flat Washer $\Phi 10 \times \Phi 20 \times 2$	34
33	GB9316DHS12	Spring Washer $\Phi 16$	2
34	GB9310DHS12	Spring Washer $\Phi 10$	12
35	NM12DHS2	Nylon Lock Nut M12	1
36	NM10DHS2	Nylon Lock Nut M10	10
37	NBS4DHS	Hex Key S=4	1
38	NBS6DHS	Hex Key S=6	1
39	NBS8DHS	Hex Key S=8	1
40	NBS12DHS	Hex Key S=12	1

Base Frame Frame ASSY (1)

Grade No.	Part no.	Description	Qty.
1.1	IFP13010100	Base Frame	1
1.2	IFP12013300	Plastic Horizontal Rectangular Shoe	2
1.3	GB17880.5M6*16.5DS17	Flat Head Hexagon Riveted Nut M6*16.5	2
1.4	GB818M6*20DHS2	Cross Recessed Pan Head Screw M6*20	2

Lat Seat Frame ASSY (3)

Grade No.	Part no.	Description	Qty.
3.1	IFP13010300	Lat Seat Frame	1
3.2	IFP12013300	Plastic Horizontal Rectangular Shoe	1
3.3	GB17880.5M6*16.5DS17	Flat Head Hexagon Riveted Nut M6*16.5	1
3.4	GB818M6*20DHS2	Cross Recessed Pan Head Screw M6*20	1

Upright Frame ASSY (4)

Grade No.	Part no.	Description	Qty.
4.1	IFP13010400	Upright Frame	1
4.2	IT90021100V1	Scaleboard	1
4.3	IN-S10111200	Stop Spacer $\Phi 17 \times 10.5$	2
4.4	GB70M8*20DHS20	Socket Head Cap Screw M8*20	2
4.5	GB958DHS2	Flat Washer $\Phi 9 \times \Phi 16 \times 1.6$	2
4.6	NM8DHS2	Nylon Lock Nut M8	2

Left Arm Frame ASSY (5)

Grade No.	Part no.	Description	Qty.
5.1	IFP13010500	Left Arm Frame	1
5.2	GB2766205-2ZC3	Deep Groove Ball Bearing $\Phi 25 \times \Phi 52 \times 15$	2
5.3	KPSFID2800	Plastic Insert Cap $\Phi 50.8 \times 76.2$	2
5.4	CWRVL0052000	Small Limit Sleeve	1
5.5	GB77M8*6DHS2	Socket Set Screw M8*6	1

Right arm Frame ASSY (6)

Grade No.	Part no.	Description	Qty.
6.1	IFP13010600	Left Arm Frame	1
6.2	GB2766205-2ZC3	Deep Groove Ball Bearing $\Phi 25 \times \Phi 52 \times 15$	2
6.3	KPSFID2800	Plastic Insert Cap $\Phi 50.8 \times 76.2$	2
6.4	CWRVL0052000	Small Limit Sleeve	1
6.5	GB77M8*6DHS2	Socket Set Screw M8*6	1

Left Frame ASSY (7)

Grade No.	Part no.	Description	Qty.
7.1	IFP13010700	Left Frame	1
7.2	RS17000400	Rubber Bumper	1
7.3	GB70M10*20DHS20NL	Socket Head Cap Screw M10*20	2
7.4	BB1500	Limit Sleeve	1
7.5	GB5780M12*155DHS20	Hex Head Bolt M12*155	1
7.6	GB9512DHS2	Flat Washer $\Phi 13.5 \times \Phi 27 \times 2$	2
7.7	NM12DHS2	Nylon Lock Nut M12	1

Right Frame ASSY (8)

Grade No.	Part no.	Description	Qty.
8.1	IFP13010800	Right Frame	1
8.2	RS17000400	Rubber Bumper	1
8.3	GB70M10*20DHS20NL	Socket Head Cap Screw M10*20	2
8.4	BB1500	Limit Sleeve	1
8.5	GB5780M12*155DHS20	Hex Head Bolt M12*155	1
8.6	GB9512DHS2	Flat Washer $\Phi 13.5 \times \Phi 27 \times 2$	2
8.7	NM12DHS2	Nylon Lock Nut M12	1

Weight Horn ASSY (10)

Grade No.	Part no.	Description	Qty.
10.1	IFP13011000	Weight Horn	1
10.2	IFP12013400	Weight Horn Sleeve $\Phi 50 \times 250$	1
10.3	IFP12013500	Weight Horn Plastic Cap	1

Weight Plate Storage ASSY (11)

Grade No.	Part no.	Description	Qty.
11.1	IFP16131600	Weight Plate Storage	1
11.2	IFP12013400	Weight Horn Sleeve $\Phi 50 \times 250$	1
11.3	IFP12013500	Weight Horn Plastic Cap	1

Foam Frame ASSY (12)

Grade No.	Part no.	Description	Qty.
12.1	IF93020800	Foam Frame	1
12.2	IT95021600	Spring Pin	1
12.3	M02502000	Bushing $\Phi 38 \times \Phi 32 \times \Phi 25.4 \times 18$	2
12.4	IF81165000	Lock Nut $\Phi 25$	2
12.5	IT90021200V1	Axle $\Phi 25.4 \times \Phi 12.5 \times 72.5$	1

Handle Frame ASSY (13)

Grade No.	Part no.	Description	Qty.
13.1	IFP13011300	Handle Frame	1
13.2	V39600	Aluminium Grip Cap $\Phi 25.4$	1
13.3	V39500	Aluminium Grip Ring $\Phi 25.4$	1
13.4	YZGB7710-32*3.2N19NL	Socket Set Screw 10-32*3.2	4
13.5	FE97203100	$\Phi 25$ Grip	1

7.3 Exploded Drawing

Overall

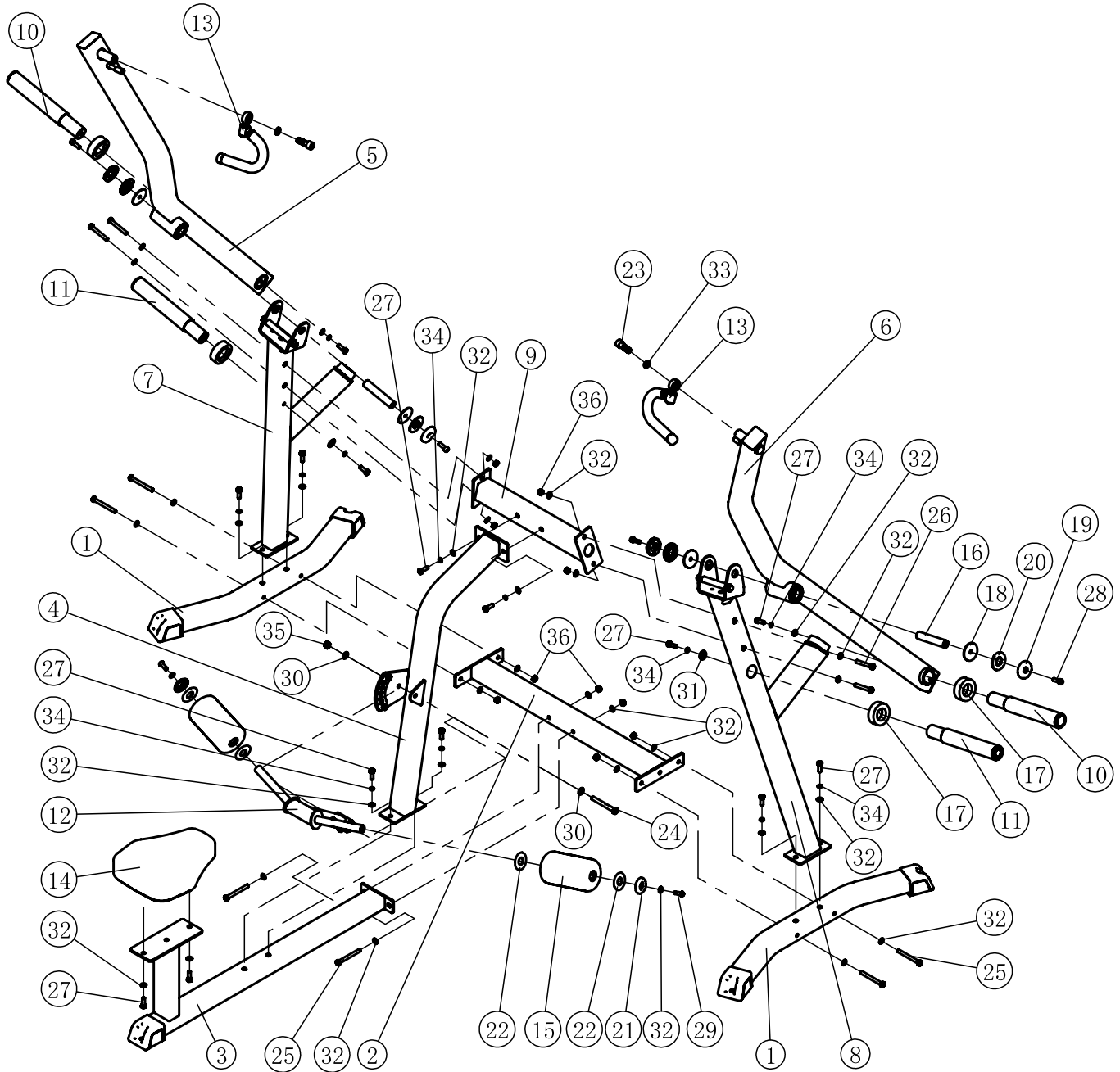

Base Frame ASSY (1)

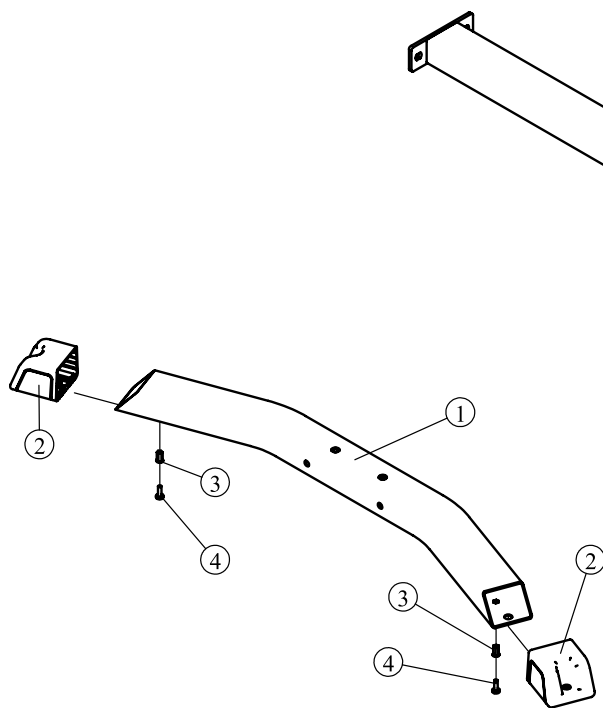

Lat Seat Frame ASSY (3)

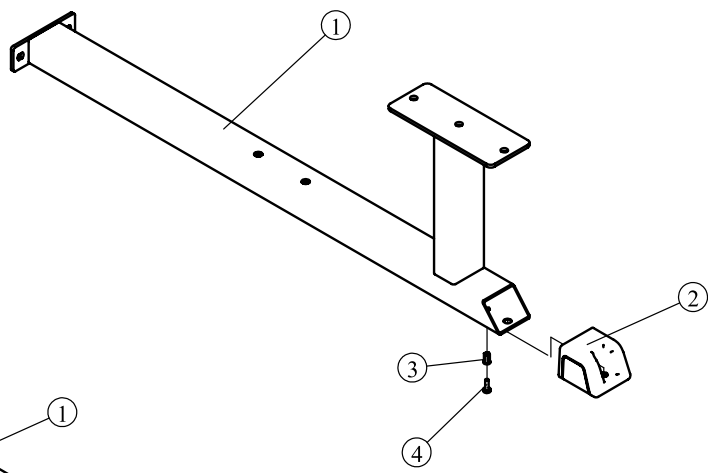

Upright Frame (4)

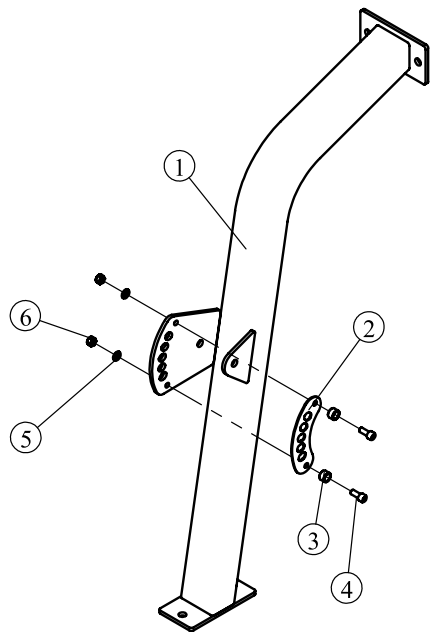

Left Arm Frame ASSY (5)

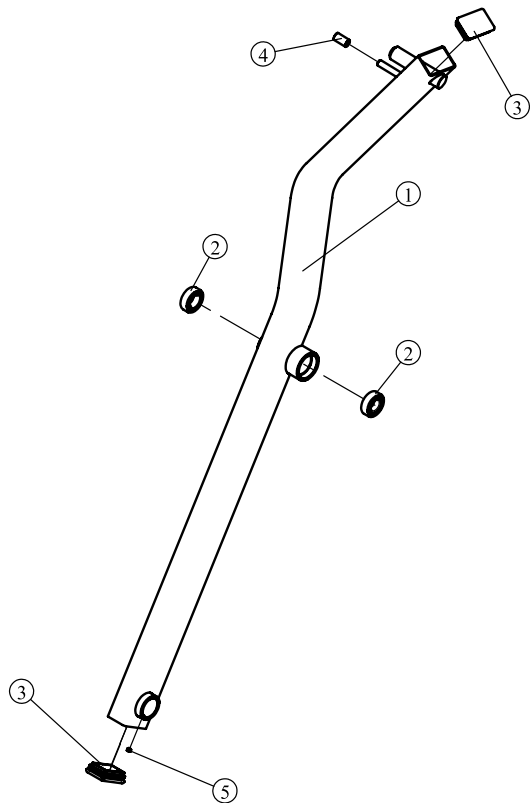

Right Arm Frame ASSY (6)

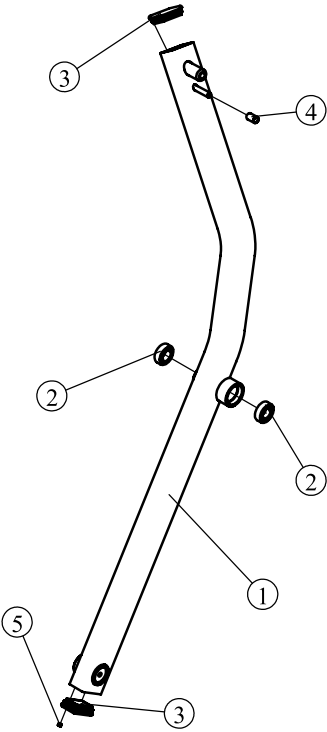

Left Frame ASSY (7)

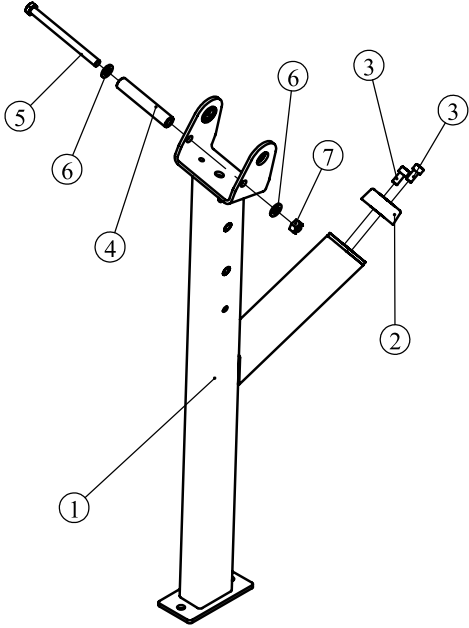

Right Frame ASSY (8)

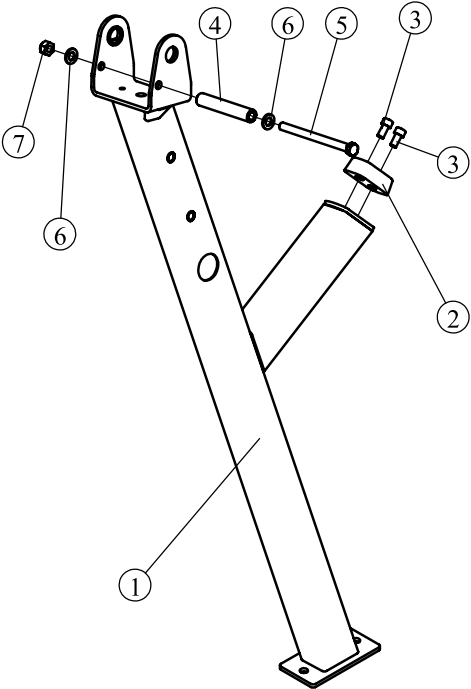

Weight Horn ASSY (10)

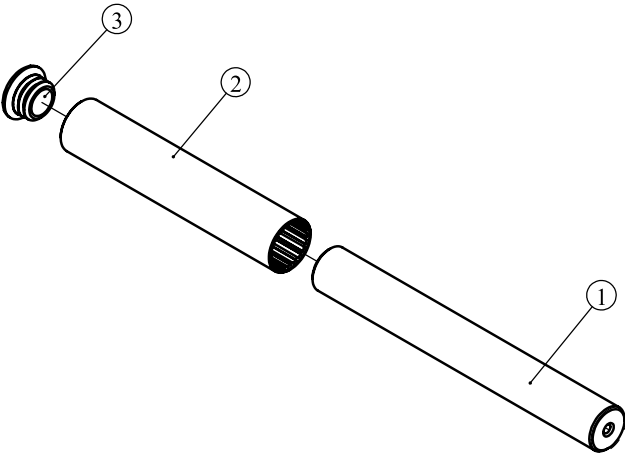

Weight Plate Storage ASSY (11)

Foam Frame ASSY (12)

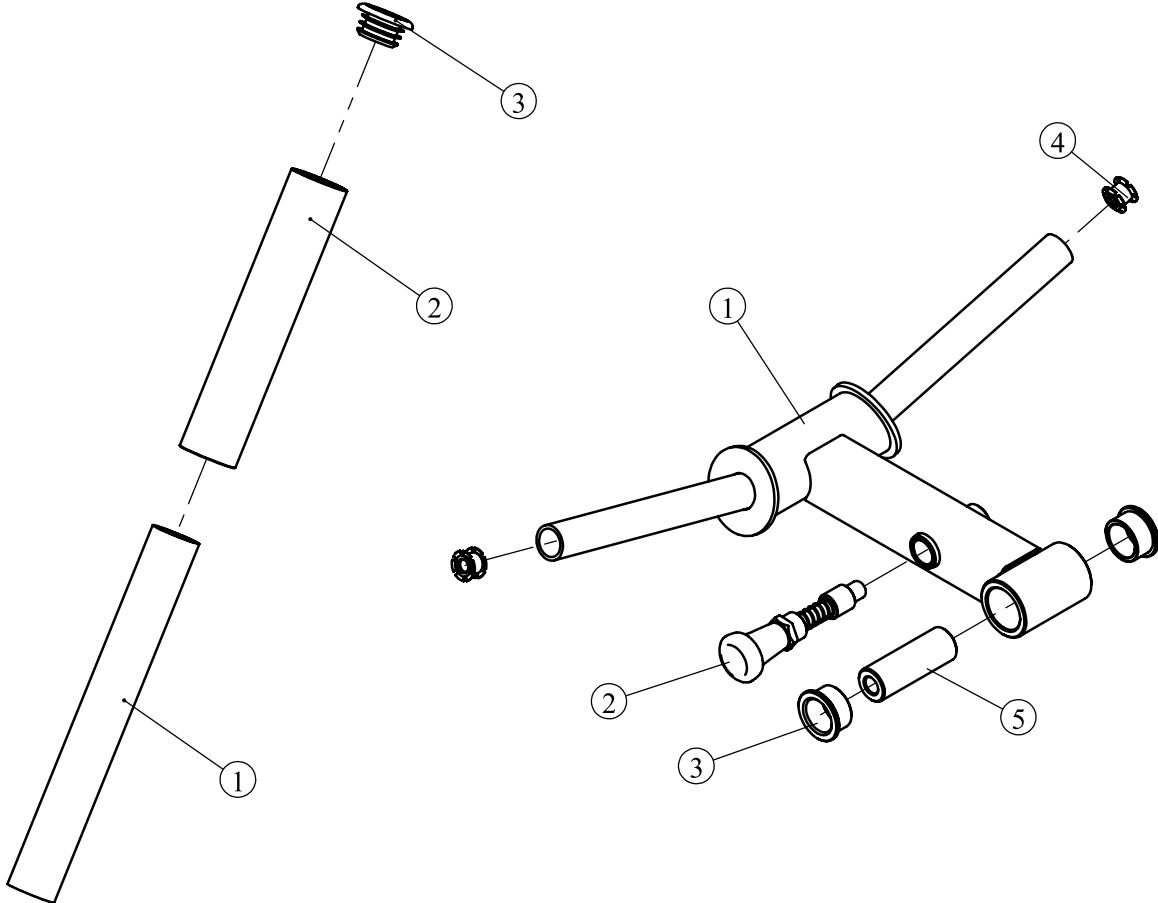

Handle Frame ASSY(13)

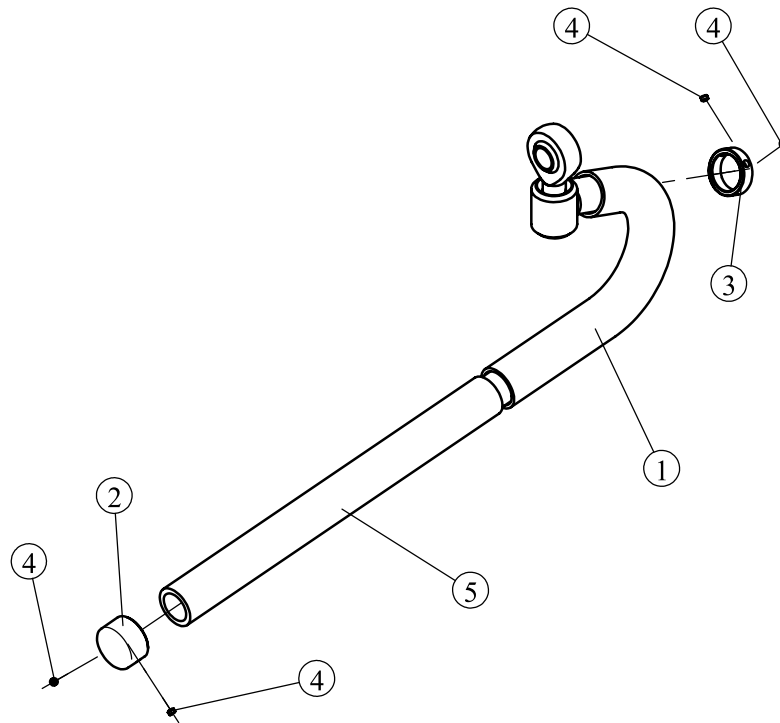

Training equipment from Taurus® is subject to strict quality control. However, if a fitness equipment purchased from us does not work perfectly, we take it very seriously and ask you to contact our customer service as indicated. We are happy to help you by phone via our service hotline.

Error Descriptions

Your fitness equipment is developed for long-term, high-quality training. However, should a problem arise, please first read the operating instructions. For further assistance, please contact your contract partner or call our service hotline. To ensure your problem is solved as quickly as possible, please describe the defect as exactly as possible.

In addition to the statutory warranty, we provide a warranty for every fitness equipment purchased from us according to the following provisions.

Your statutory rights are not affected.

Warrantee

The warrantee is the first/original buyer.

Warranty periods

The following warranty periods begin on delivery of the fitness equipment.

Warranty period

The warranty periods, shown on our web shop, begin on delivery of the fitness equipment. The respective warranty periods for your equipment can be found on its product website.

Repair Costs

According to our choice, there will either be a repair, a replacement of individual damaged parts or a complete replacement. Spare parts, that have to be mounted while assembling the equipment, have to be replaced by the warrantee personally and are not a part of repair. After the expiration of the warranty period, the responsibility for parts costs, repair costs, installation costs and delivery costs lies with the warranty holder.

The terms of use are defined as follows:

- + Home use: solely for private use in private households up to 3 hours per day
- + Semi-professional use: up to 6 hours per day (e. g. rehabilitation centres, hotels, clubs, company gyms)
- + Professional use: more than 6 hours per day (e. g. commercial gyms)

Warranty Service

Within the warranty period, equipment which develops faults as a result of material or manufacturing defects, will be repaired or replaced at our discretion. Ownership of equipment or parts of equipment which have been replaced is transferred to us. The warranty period is not extended nor does a new warranty period begin following repair or replacement under the warranty.

Warranty Conditions

For the warranty to be valid, the following steps must be taken:

Please contact our customer service by email or phone. If the product under warranty has to be sent in for repair, the seller bears costs. After expiry of the warranty, the buyer bears the costs of transport and insurance. If the fault is covered by our warranty, you will receive a new or repaired equipment in return.

Warranty claims are invalid in case of damage resulting from:

- + misuse or improper handling
- + environmental influences (moisture, heat, electrical surge, dust, etc.)
- + failure to follow the current safety measures for the equipment
- + failure to follow the operating instructions
- + use of force (e. g. hitting, kicking, falling)
- + interventions which were not carried out by one of our authorized service centres
- + unauthorised repair attempts

Proof of Purchase and Serial Number

Please make sure that you are able to provide the appropriate receipt when claiming on your warranty. So that we can clearly identify the model of your equipment, and for the purposes of our quality control, you will need to give the serial number of your equipment, when contacting the service team. Where possible please have your serial number and your customer number ready when you call our service hotline. It will help us to deal with your request swiftly.







































If you cannot find the serial number on your fitness equipment, our service team is at your disposal to offer further information.

Service outside of the Warranty Period

We are also happy to issue an individual cost estimate if there is a problem with your fitness equipment after the warranty has expired, or in cases which do not fall under the terms of the warranty, e. g. normal wear and tear. Please contact our customer service team to find a quick and cost-effective solution to your problem. In such a case you will be responsible for the delivery costs.

Communication

Many problems can be solved just by speaking to us as your specialist supplier. We know how important it is to you as a user of the fitness equipment to have problems solved quickly and simply, so you can enjoy working out with minimal interruption. For that reason, we also want to resolve your queries quickly and in a straightforward manner. Thus, please always keep your customer number and the serial number of the faulty equipment handy.

DE	DK	FR
<p>TECHNIK</p> <p> +49 4621 4210-900</p> <p> +49 4621 4210-698</p> <p> technik@sport-tiedje.de</p> <p> Öffnungszeiten entnehmen Sie unserer Homepage.</p> <p>SERVICE</p> <p> 0800 20 20277 (kostenlos)</p> <p> 04621 4210 - 0</p> <p> info@sport-tiedje.de</p> <p> Öffnungszeiten entnehmen Sie unserer Homepage.</p>	<p>TEKNIK OG SERVICE</p> <p> 80 90 16 50</p> <p>+49 4621 4210-945</p> <p> info@fitshop.dk</p> <p> Åbningstider kan findes på hjemmesiden.</p>	<p>TECHNIQUE & SERVICE</p> <p> +33 (0) 189 530984</p> <p>+49 4621 42 10 933</p> <p> info@fitshop.fr</p> <p> Vous trouverez les heures d'ouverture sur notre site Internet.</p>
	PL	BE
	<p>DZIAŁ TECHNICZNY I SERWIS</p> <p> 22 307 43 21</p> <p>+49 4621 42 10-948</p> <p> info@fitshop.pl</p> <p> Godziny otwarcia można znaleźć na stronie głównej.</p>	<p>TECHNIQUE & SERVICE</p> <p> 02 732 46 77</p> <p>+49 4621 4210 933</p> <p> info@fitshop.be</p> <p> Vous trouverez les heures d'ouverture sur notre site Internet.</p>
UK	NL	INT
<p>CUSTOMER CARE POWERHOUSE</p> <p> +44 141 737 2249 or +44 141 876 3972</p> <p> customercare@powerhouse-fitness.co.uk</p> <p> You can find the opening hours on our homepage.</p>	<p>TECHNISCHE DIENST & SERVICE</p> <p> +31 172 619961</p> <p> service@fitshop.nl</p> <p> De openingstijden vindt u op onze homepage.</p>	<p>TECHNICAL SUPPORT & SERVICE</p> <p> +49 4621 4210-944</p> <p> service-int@sport-tiedje.de</p> <p> You can find the opening hours on our homepage.</p>
ES	AT	CH
<p>TECNOLOGÍA Y SERVICIOS</p> <p> 911 238 029</p> <p> info@fitshop.es</p> <p> Consulta nuestro horario de apertura en la página web.</p>	<p>TECHNIK & SERVICE</p> <p> 0800 20 20277 (Freecall)</p> <p>+49 4621 42 10-0</p> <p> info@sport-tiedje.at</p> <p> Öffnungszeiten entnehmen Sie unserer Homepage.</p>	<p>TECHNIK & SERVICE</p> <p> 0800 202 027</p> <p>+49 4621 42 10-0</p> <p> info@sport-tiedje.ch</p> <p> Öffnungszeiten entnehmen Sie unserer Homepage.</p>

Please find a detailed overview including address and opening hours for all stores of Powerhouse Fitness in the UK on the following website:

www.powerhouse-fitness.co.uk/storelocator

WE LIVE FITNESS

WEBSHOP AND SOCIAL MEDIA

The Sport-Tiedje Group is Europe's largest specialist for home fitness equipment with currently 70 stores and one of the world's most renowned online mail order companies for fitness equipment.

Powerhouse Fitness is part of the Sport-Tiedje Group. Private customers order via the 25 web shops in the respective national language or have their desired equipment assembled on site. In addition, the company supplies fitness studios, hotels, sports clubs, companies and physio practices with professional equipment for endurance and strength training.

The Sport-Tiedje group offers a wide range of fitness equipment from renowned manufacturers, high-quality in-house developments and comprehensive services, such as a build-up service and sports scientific advice before and after the purchase. The company employs numerous sports scientists, fitness trainers and competitive athletes.

Visit us also on our social media platforms or our blog!



<http://www.powerhouse-fitness.co.uk/>
www.powerhouse-fitness.co.uk/blog/



<https://www.facebook.com/powerhousefitness.co.uk>



www.instagram.com/powerhousefitness_uk/



www.youtube.com/user/PHFTV/

TAURUS

 cardiostrong

BODYCRAFT

 **BodyMax**
PERFORMANCE WITHOUT COMPROMISE

Notes

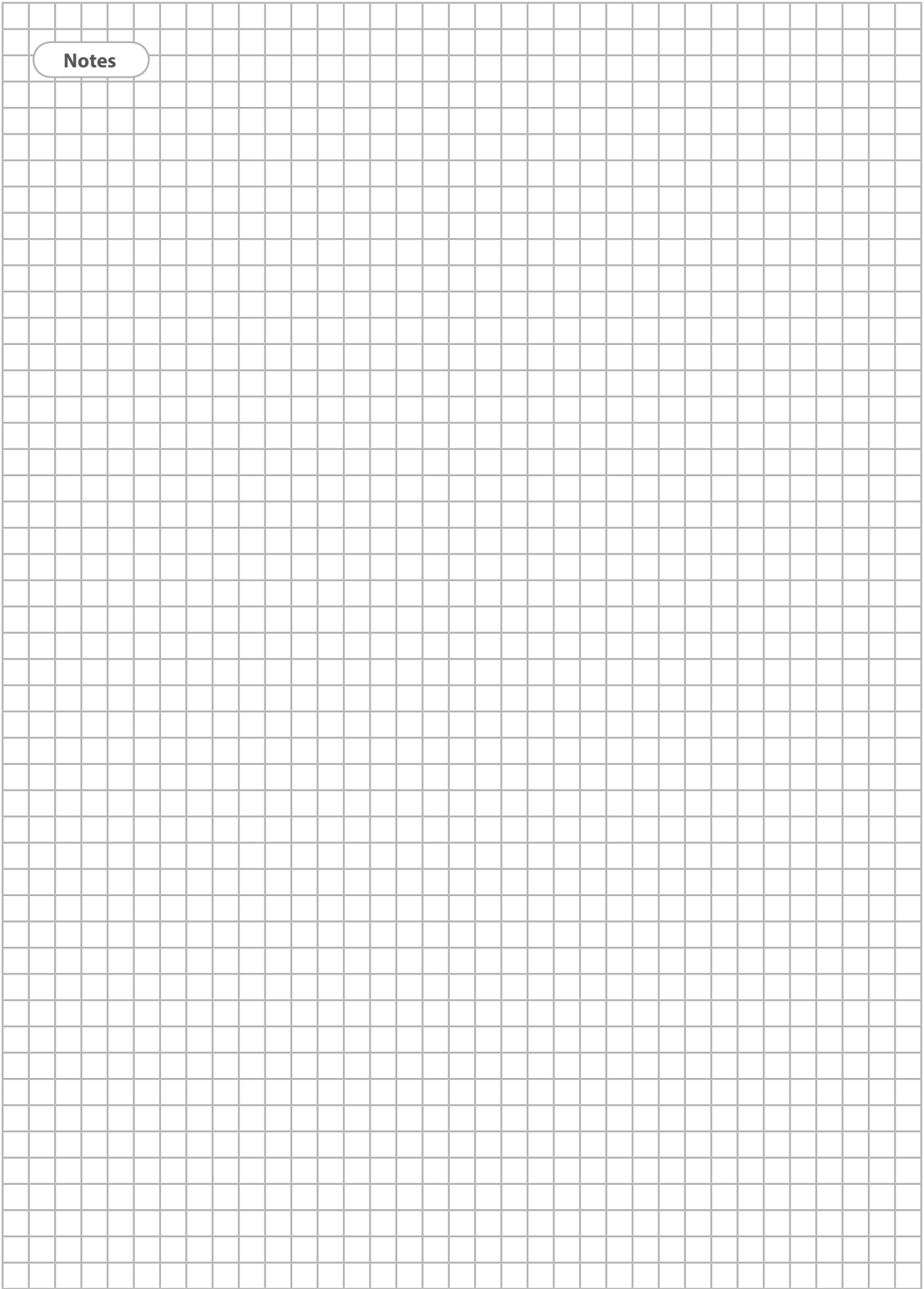

Notes

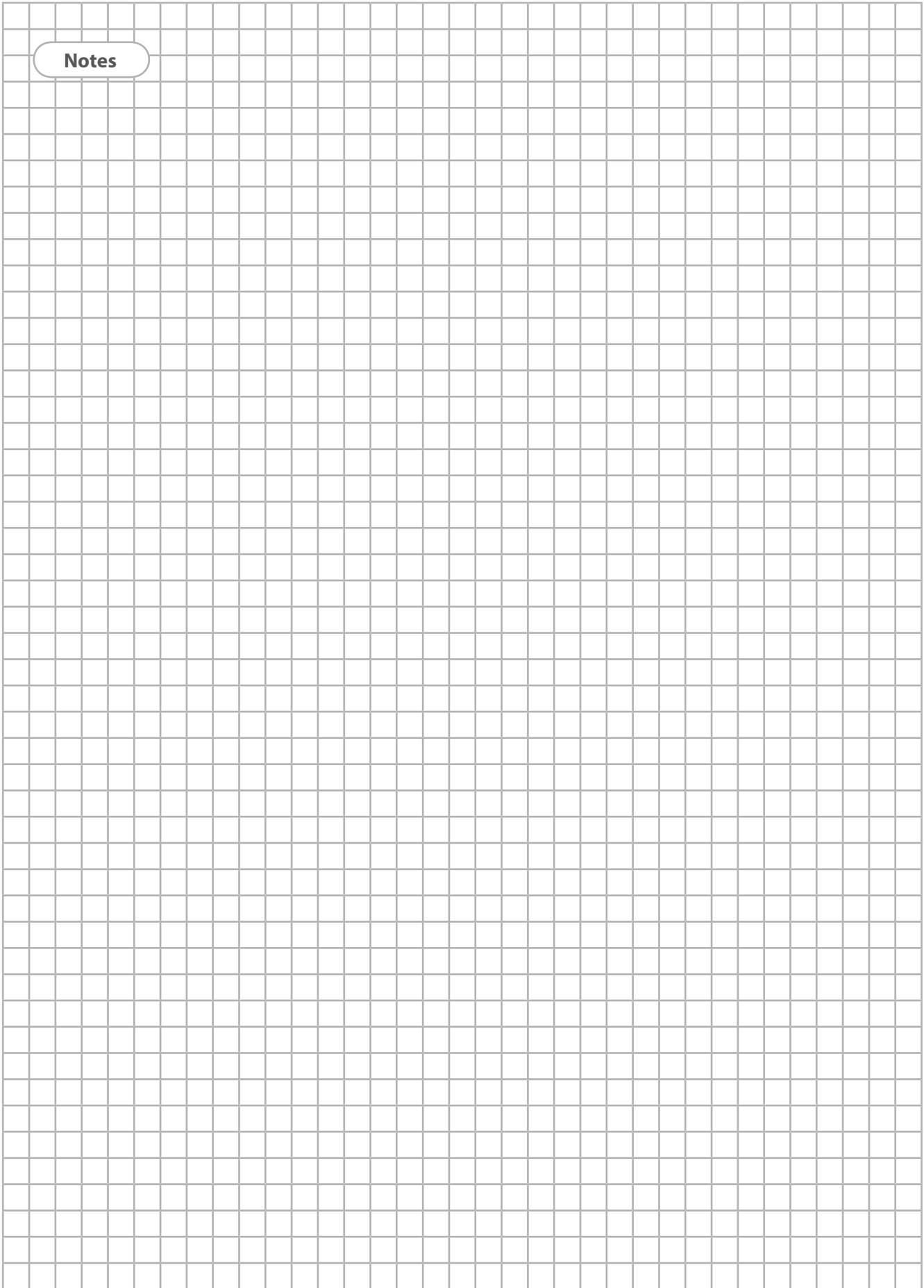

TAURUS®

Taurus Pro Lat Pulldown