

# TAURUS®

## Assembly and Operating Instructions

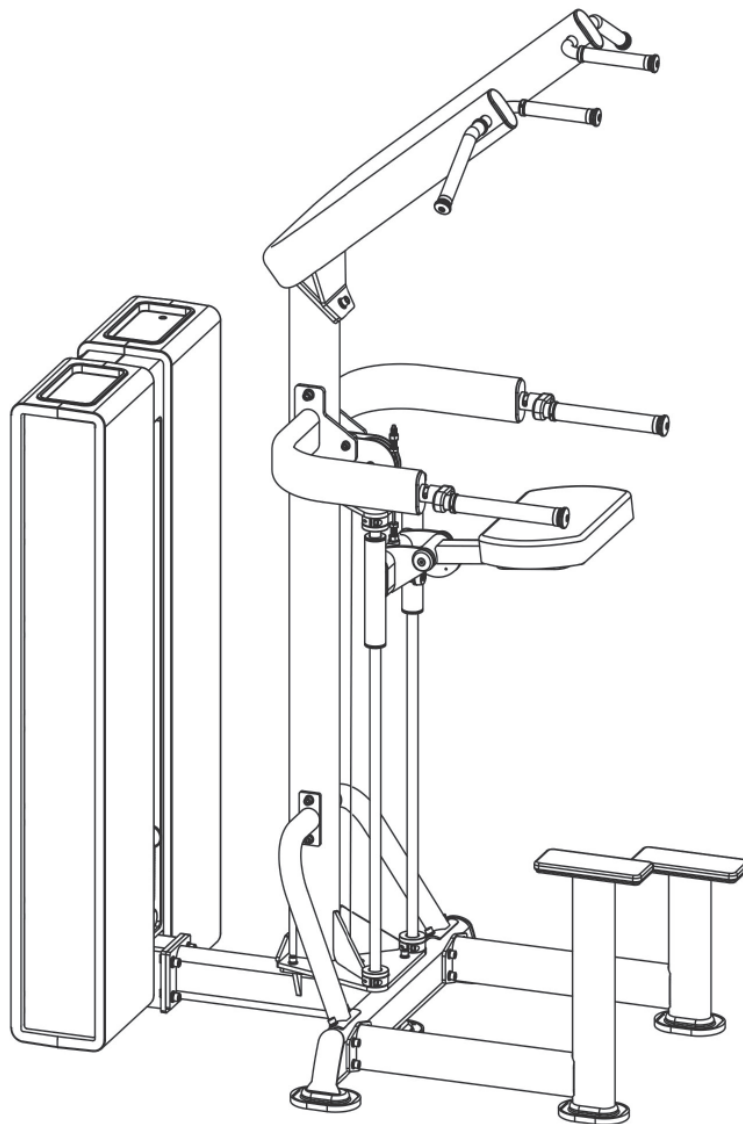

max. 180 kg



~ 180 Min. 



 236 kg

L 116 | W 154 | H 220

FSUKSESS7133.01.01

SKU: SESS7133

**Taurus Dual Pro Assisted Chin & Dip**



# Content

<b>1</b>	<b>GENERAL INFORMATION</b>	<b>7</b>
1.1	Technical Data	7
1.2	Personal Safety	8
1.3	Set-Up Place	9
<b>2</b>	<b>ASSEMBLY</b>	<b>10</b>
2.1	General Instructions	10
2.2	Scope of Delivery	10
2.3	Assembly	14
<b>3</b>	<b>STORAGE AND TRANSPORT</b>	<b>30</b>
3.1	General Instructions	30
<b>4</b>	<b>TROUBLESHOOTING, CARE AND MAINTENANCE</b>	<b>31</b>
4.1	General Instructions	31
4.2	Faults and Fault Diagnosis	31
4.3	Maintenance and Inspection Calendar	32
<b>5</b>	<b>DISPOSAL</b>	<b>32</b>
<b>6</b>	<b>RECOMMENDED ACCESSORIES</b>	<b>33</b>
<b>7</b>	<b>ORDERING SPARE PARTS</b>	<b>34</b>
7.1	Serial Number and Model Name	34
7.2	Parts List	35
7.3	Exploded Drawing	39
<b>8</b>	<b>WARRANTY</b>	<b>41</b>
<b>9</b>	<b>CONTACT</b>	<b>43</b>



**Dear customer,**

Thank you for choosing quality training equipment from the TAURUS brand. Taurus offers sports and fitness equipment for home users with high demands on quality, functionality and longevity. Also, Taurus is a well-known and experienced brand for equipping professional rooms for fitness studios and business customers. The focus of Taurus fitness equipment is on what matters most in sports: maximum performance! Therefore, the devices are developed in close consultation with athletes and sports scientists. Because athletes know best what makes perfect fitness equipment.

Further information can be found at [www.fitshop.co.uk](http://www.fitshop.co.uk)

**Intended Use**

The equipment may only be used for its intended purpose.

This fitness equipment is suitable for home use, semi-professional use and commercial or professional use. The semi-professional sector includes, for example, institutional facilities such as hospitals, schools, hotels and associations. Professional use refers to commercial use, e.g. in a fitness studio.

**Legal Notice**

Fitshop GmbH  
Europe's No. 1 for home fitness

International Headquarters  
Flensburger Straße 55  
24837 Schleswig  
Germany

Management:  
Christian Grau  
Sebastian Campmann  
Dr. Bernhard Schenkel  
No. HRB 1000 SL  
Local Court Flensburg  
European VAT Number: DE813211547

**Disclaimer**

© TAURUS is a registered brand of the company Fitshop GmbH. All rights reserved. Any use of this trademark without the explicit written permission of Fitshop is prohibited.

Product and manual are subject to change. Technical data can be changed without advance notice.

# **FITSHOP**

Europe's No.1 for Home Fitness

## ABOUT THIS MANUAL

Please carefully read the entire manual before installation and first use. The manual will help you to quickly set up the system and explains how to safely use it. Make sure that all persons exercising with the equipment (especially children and persons with physical, sensory, mental or motor disabilities) are informed about this manual and its contents in advance. In case of doubt, responsible persons must supervise the use of the equipment.

Due to ongoing changes and software optimisations, the manual may have to be updated. If you notice any discrepancies during assembly or use, please refer to the manual uploaded to the webshop. The latest manual is always available there.



This equipment has been manufactured according to the latest safety knowledge. As far as possible, potential safety hazards which could cause injury have been eliminated. Make sure to carefully follow the instructions and that all parts are securely in place. If required, read through the instructions again to correct any mistakes.

Training devices must be classified according to accuracy and use. Accuracy classes are only applicable to devices that display training data.

### Accuracy classes

Class A: high accuracy.

Class B: medium accuracy.

Class C: low accuracy.

The use classes explain the intended use of the training device.

### Use classes

**Class S** (studio): professional and/or commercial use.

These training devices are intended for the use in training rooms of facilities such as sports clubs, school facilities, hotels, clubs and studios whose access and supervision is specifically regulated by the owner (person with legal responsibility).

**Class H** (home use): use at home.

These stationary training devices are intended for the use in private homes where access to the training device is regulated by the owner (person with legal responsibility).

Please pay close attention to the safety and maintenance instructions given here. The contract partner cannot be held liable for damage to health, accidents or damage to the equipment when it is not used in accordance with these instructions.

The following safety instructions may appear in this manual:

► **ATTENTION**

This notice indicates potentially hazardous situations which, if not avoided, may result in property damage.

⚠ **CAUTION**

This notice indicates potentially hazardous situations which, if not avoided, may result in slight or minor injuries!

⚠ **WARNING**

This notice indicates potentially hazardous situations which, if not avoided, may result in death or serious injuries!

⚠ **DANGER**

This notice indicates potentially hazardous situations which, if not avoided, will result in death or serious injuries!

ⓘ **NOTICE**

This notice indicates further useful information.

Retain these instructions in a safe place for future reference, maintenance or when ordering replacement parts.

## 1.1 Technical Data

### Weight and Dimensions

Packaging dimensions (L x W x H) and article weight (gross, incl. packaging):

Box 1:	163 cm x 91 cm x 19.5 cm	25 kg / 55 lbs
Box 2:	152 cm x 89 cm x 28.5 cm	35 kg / 77 lbs
Box 3:	170 cm x 103.5 cm x 36 cm	125 kg / 275 lbs
Box 4:	45 cm x 9 cm x 30 cm	6.5 kg / 14 lbs
Box 5 (weight plates):	30.5 cm x 11.5 cm x 12.5 cm	70 kg/154 lbs in total

Set-up dimensions (L x W x H):	116.4 cm x 154.3 cm x 220 cm
Article weight (net, without packaging):	236.2 kg / 520 lbs
Maximum user weight:	180 kg / 396 lbs

### Weight Stack

Weight stack:	1
Weight plates:	7 x 10 lbs, 5 x 20 lbs + 1 top plate
Cable material:	Steel
Cover material:	Nylon
Cable length:	4625 mm
Transmission ratio:	1:1
Use class:	S



## 1.2 Personal Safety

### **DANGER**

- + Before you start using the equipment, you should consult your physician that this type of exercise is suitable for you from a health perspective. Particularly affected are persons who: have a hereditary disposition to high blood pressure or heart disease, are over the age of 45, smoke, have high cholesterol values, are overweight and/or have not exercised regularly in the past year. If you are under medical treatment that affects your heart rate, medical advice is absolutely essential.
- + Note that excessive training can seriously endanger your health. Please also note that heart rate monitoring systems can be inaccurate. If you notice any signs of weakness, nausea, dizziness, pain, shortness of breath, or other abnormal symptoms, stop exercising immediately and seek advice from your doctor if necessary.
- + The owner must communicate all warnings and instructions to the user.

### **WARNING**

- + This equipment may not be used by children under the age of 14.
- + Children should not be allowed unsupervised access to the equipment.
- + Persons with disabilities must have a medical license and must be under strict observation when using the equipment.
- + The equipment is strictly for use by one person at a time.
- + Keep your hands, feet and other body parts, hair, clothing, jewellery and other objects well clear of moving parts.
- + During use, wear suitable sports clothing rather than loose or baggy clothing. When wearing sports shoes, make sure they have suitable soles, preferably made of rubber or other non-slip materials. Shoes with heels, leather soles, studs or spikes are unsuitable. Never exercise barefoot.
- + Always start each workout with a light warm-up and end with a cool-down phase.
- + Using the machine as a support during stretching exercises or attaching resistance bands, ropes or other accessories to it, may cause injuries.

### **CAUTION**

- + If your equipment needs to be connected to the power supply with a mains cable, make sure that the cable is not a potential tripping hazard.
- + Make sure that nobody is within the range of motion of the equipment during training so as not to endanger you or other persons.
- + Be aware that if adjustment devices are left protruding, they may impede the user's movement.
- + The weights should remain in the user's field of vision during the entire exercise to prevent danger to third parties.

### **ATTENTION**

- + Do not insert any objects of any kind into the openings of the device.

## 1.3 Set-Up Place

### **WARNING**

- + Do not place the equipment in main corridors or escape routes.

### **CAUTION**

- + Choose a location in which to place the equipment such that there is enough free space/clearance to the front, the rear and to the sides of the equipment.
- + The training room should be well ventilated during training and not be exposed to any draughts.
- + Choose the place in which to set up the equipment such that there is enough free space/clearance to the front, the rear and to the sides of the equipment.
- + The free area in the direction from which the exercise equipment is accessed must be at least 0.6 m larger than the exercise area.
- + The set-up and mounting surface of the equipment should be flat, loadable and solid.
- + If your device is to be mounted on the wall/ceiling, make sure that you use the appropriate assembly material to avoid possible damages or personal injuries. The contractual partner accepts no liability for this.

### **ATTENTION**

- + The device may only be used in one building, in sufficiently tempered and dry rooms (ambient temperatures between 10°C and 35°C). The equipment should not be used outdoors or in rooms with high humidity (over 70%) like swimming pools.
- + A floor protective mat/equipment underlay can help to protect high-quality floor coverings (parquet, laminate, cork, carpets) from dents and sweat and can help to level out slight unevenness.
- + For Class S equipment, the exercise equipment may only be used in areas where access, supervision and control are specifically regulated by the owner.

### 2.1 General Instructions



#### **DANGER**

- + Do not leave any tools, packaging materials such as foils or small parts lying around, as otherwise there is a danger of suffocation for children. Keep children away from the equipment during assembly.



#### **WARNING**

- + Pay attention to the instructions attached to the equipment in order to reduce the risk of injuries.



#### **CAUTION**

- + Ensure to have sufficient room for movement in each direction during assembly.
- + The assembly of the equipment must be carried out by at least two adults. If in doubt, seek the help of a third technically skilled person.



#### **ATTENTION**

- + To prevent damage to the equipment and the floor, assemble the equipment on a mat or packaging board.



#### **NOTICE**

- + In order to make the assembly as simple as possible, some screws and nuts to be used can already be pre-assembled.
- + Ideally, assemble the equipment at its later set-up place.









### 2.2 Scope of Delivery



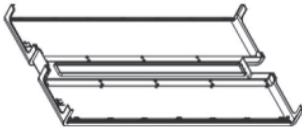
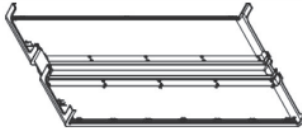
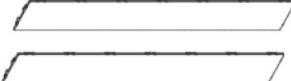

The scope of delivery consist of the following parts. At the beginning, check whether all parts and tools belonging to the device are included in the scope of delivery and whether damage has occurred. In the event of complaints, the contractual partner must be contacted directly.

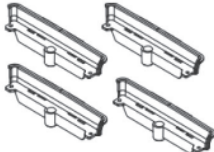

#### **CAUTION**

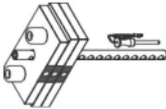
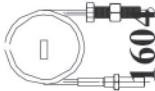
- If parts of the scope of delivery are missing or damaged, the assembly must not be carried out.

Number	Name		Quantity
001	Frame		1
013	Pulley set (ø114)		1
012	Pulley set (ø89)		1
004	Pulley baffle		1
005 + 008 + 006	Left shield + rear middle trim + right shield		1
005 + 009 + 006	Left shield + front middle trim + right shield		1
007	Side shield		2
010	Tray		2
011	Connecting strip		4
59 & 60	10lb weight stack plate		11 + 1
61	20lb weight stack plate		2

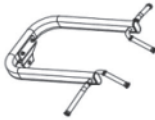
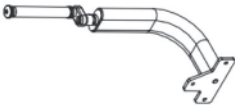
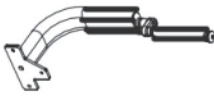
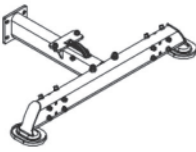
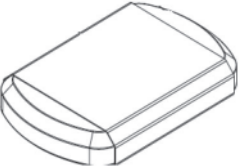
48	10lb top weight		1
46	Cable set		1
33-2	High foot frame		1
43	Short foot frame		1
36-2	Left parallel bars frame		1
37-2	Right parallel bars frame		1
42	Horizontal bar bracket		1
40	Left bracket		1
41	Right bracket		1
35-2	Joint frame		1
105	Leg pad		1

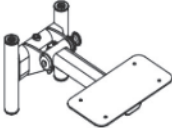
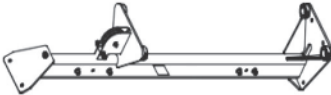
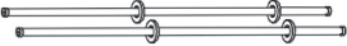
38	Glide frame		1
34-2	Main frame		1
54	Sliding guide rod		2

## 2.3 Assembly

Before assembly, take a close look at the individual assembly steps shown and carry out the assembly in the order given.

### **NOTICE**

- + First loosely screw all parts together and check that they fit properly. Tighten the screws using the tool only when you are instructed to do so.
- + If you have difficulty recognising the graphics, we recommend that you open and/or download the PDF instructions stored in the webshop on your end device (e.g. smartphone, tablet or PC). There you have the option of zooming in closer. Please note that the Adobe Acrobat Reader programme must be installed on your end device in order to open the file.

### **Step 1: Assembly of the Frame and Foot Frames**

1. Fix the joint frame (35-2) to the frame (001) with four screws (027), four spring washers (033-1) and four flat washers (032).
2. Fix the high foot frame (33-2) and the short foot frame (43) to the joint frame (001) with a total of eight screws (86), eight spring washers (98) and eight plain washers (101).

No.	Name	Specification	Qty.
001	Frame		1
027	Hex socket countersunk head screw	M12*30	4
032	Flat washer	Φ24*Φ13*2.5	4
033-1	Spring washer	M12	4
33-2	High foot frame		1
35-2	Joint foot frame		1
43	Short foot frame		1
86	Hex socket head cap screw	M10*25	8
98	Spring washer	M10	8
101	Plain washer	Φ20*Φ10.5*2	8

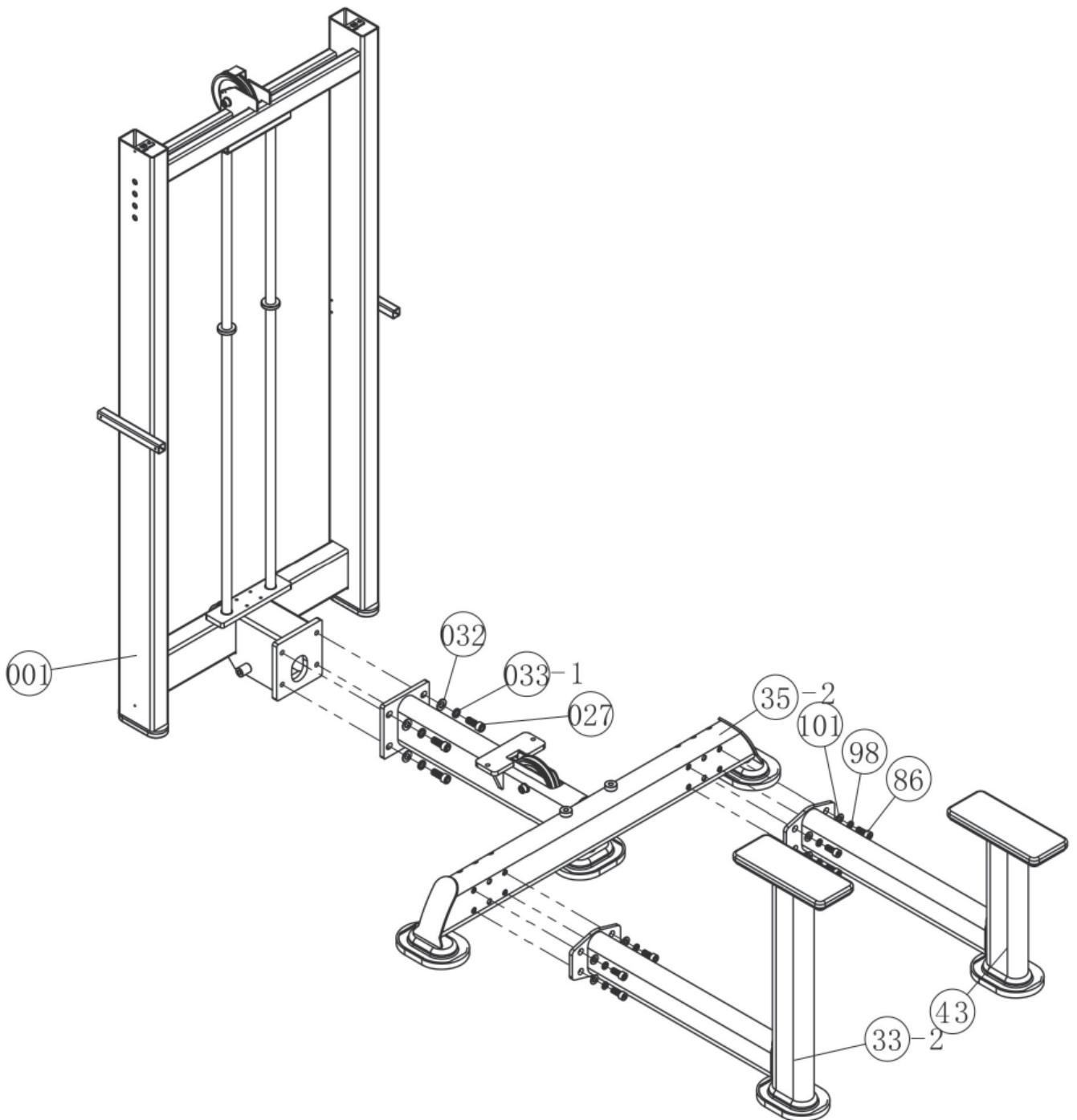



## Step 2: Assembly of the Main Frame, Pulleys and Cable Routing

### NOTICE

- + The majority of the pulleys are pre-assembled when delivered. These pulleys (65) need to be disassembled in order to perform the cable routing.
- + The two pulleys (012 and 013) for the frame are not pre-assembled.

1. Pass the cable (46) over the pulley (013) [point A] and fix the pulley (013) to the upper side of the frame (001) and pulley baffle (004) with the pre-assembled screw (026), two flat washers (031) and one nut (034-1).
2. Pass the cable (46) down and under the pulley (012) [point B] and fix the pulley (012) to the lower side of the frame (001) with the pre-assembled screw (025), two flat washers (031) and one nut (034-1).
3. Disassemble the pulley (65) [point C], pass the cable (46) below the pulley (65) and reassemble the pulley (65).

### CAUTION

Make sure to pass the cable through the opening of the main frame before mounting it.

4. Now fix the main frame (34-2) to the joint frame (35-2) with four screws (86), four spring washers (98) and four plain washers (101).
5. Disassemble the pulley (65) [point D], pass the cable (46) over the pulley (65) and reassemble the pulley (65).

### NOTICE

The cable ends will be attached later during assembly.

No.	Name	Specification	Qty.
012	Pulley set	φ89*25.8	1
013	Pulley set	φ114*32	1
34-2	Main frame		1
35-2	Joint frame		1
46	Cable		1
86	Hex socket head cap screw	M10*25	4
98	Spring washer	M10	4
101	Plain washer	Φ20*Φ10.5*2	4

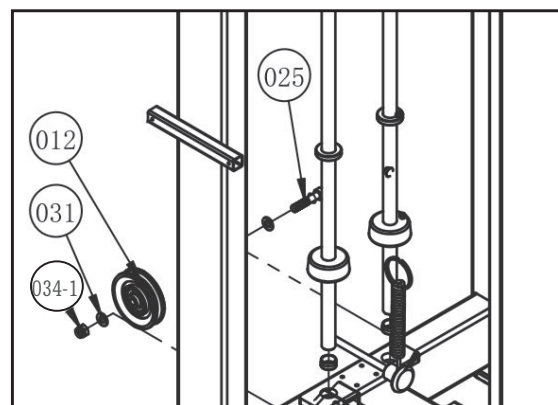
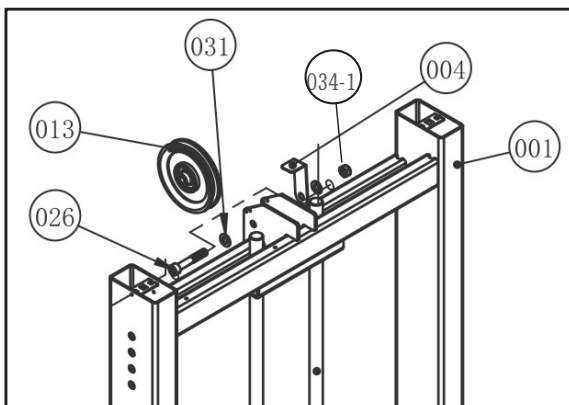

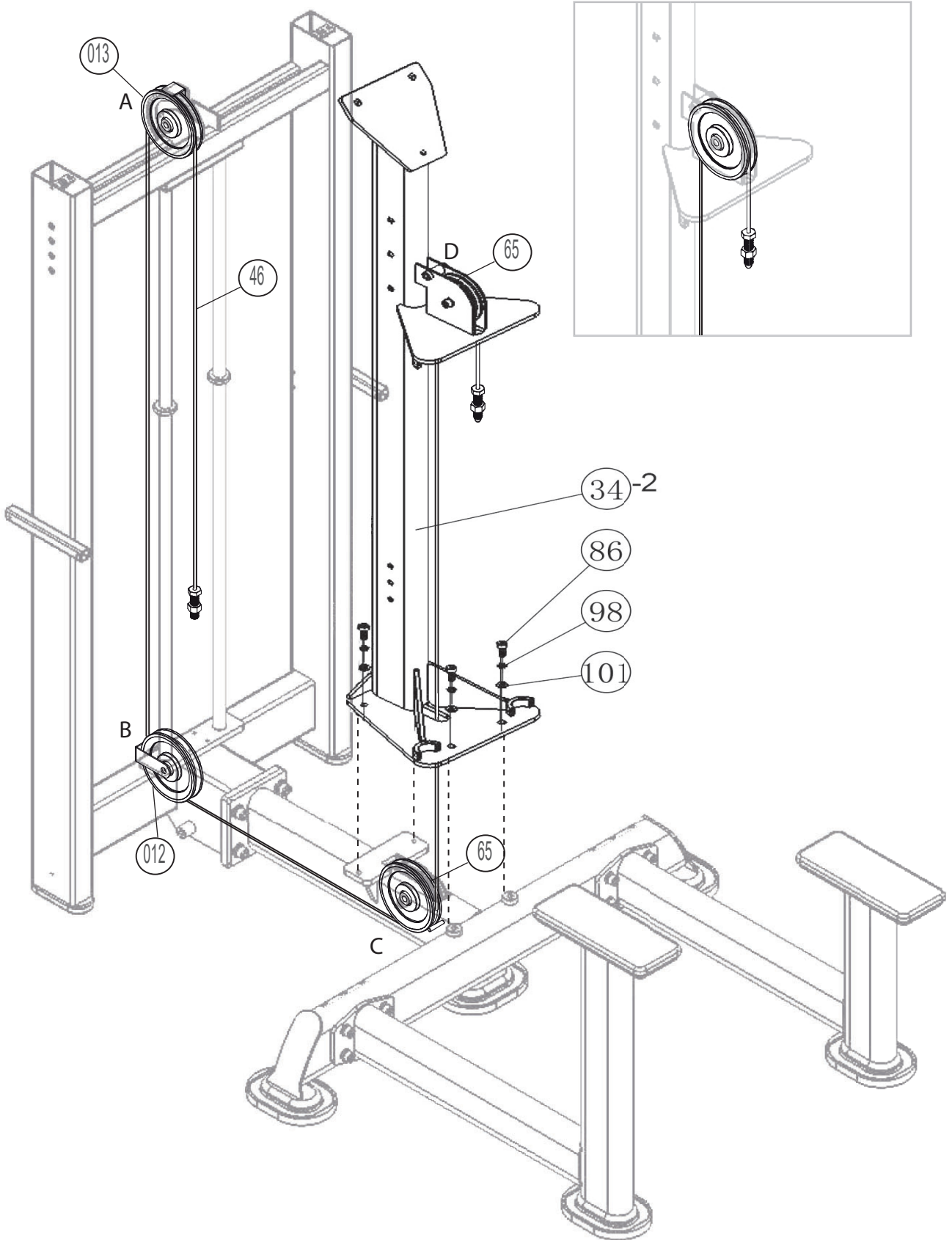

### Step 3: Assembly of the Parallel Bars and Brackets

1. Fix the left and right parallel bars frame (36-2 & 37-2) to the main frame (34-2) with a total of four screws (90), four spring washers (99) and four plain washers (102) as well as one screw (89), two plain washer (101) and one lock nut (103).
2. Fix the left bracket (40) to the main frame (34-2) and the joint frame (35-2) with a total of four screws (86), four spring washers (98) and four plain washers (101).
3. Repeat step 2 with the right bracket (41).

No.	Name	Specification	Qty.
34-2	Main frame		1
36-2	Left parallel bars frame		1
37-2	Right parallel bars frame		1
40	Left bracket		1
41	Right bracket		1
86	Hex socket head cap screw	M10*25	8
89	Hex socket head cap screw	M10*85	1
90	Hex socket head cap screw	M12*30	4
98	Spring washer	M10	8
99	Spring washer	M12	4
101	Plain washer	Φ20*Φ10.5*2	10
102	Plain washer	Φ24*Φ13*2.5	4
103	Nylon insert lock nut	M10	1

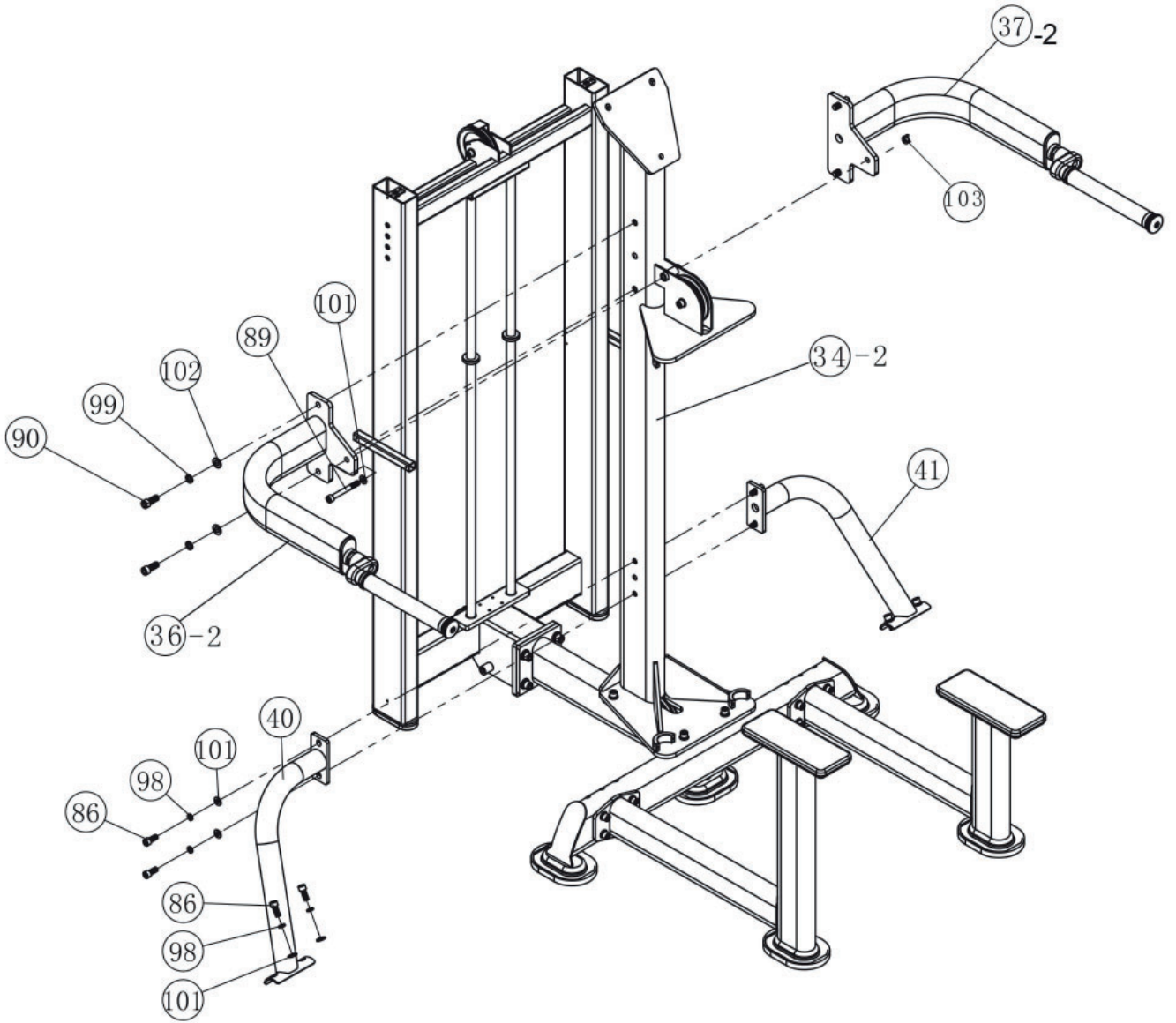

#### Step 4: Assembly of the Horizontal Bar Bracket

Fix the horizontal bar bracket (42) to the main frame (34-2) with two screws (91), four plain washers (102) and two lock nuts (104) as well as one screw (90), one spring washer (99) and one plain washer (102).

No.	Name	Specification	Qty.
34-2	Main frame		1
42	Horizontal bar bracket		1
90	Hex socket head cap screw	M12*30	1
91	Hex socket head cap screw	M12*90	2
99	Spring washer	M12	1
102	Plain washer	Φ24*Φ13*2.5	5
104	Nylon insert lock nut	M12	2

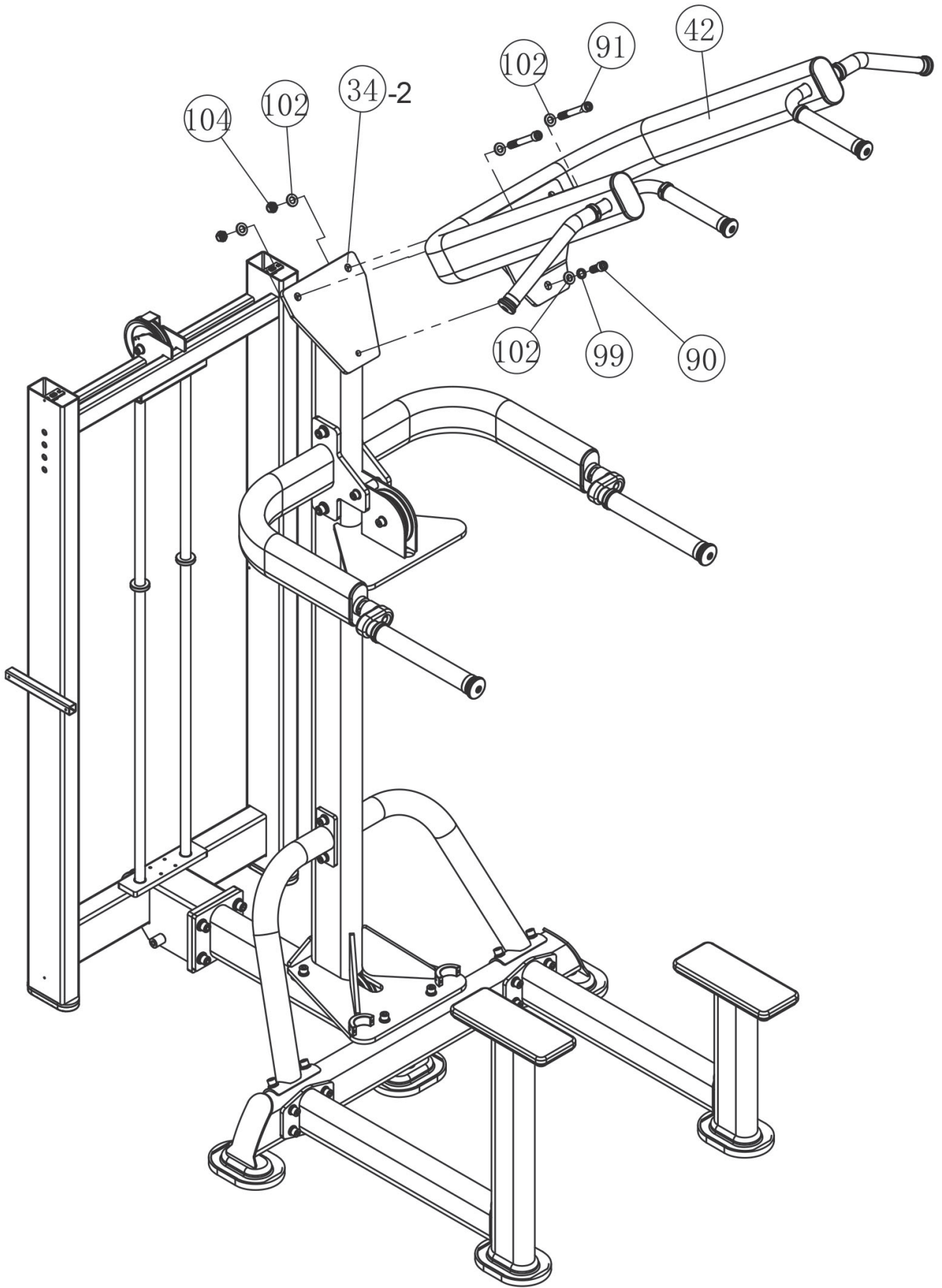

### Step 5: Assembly of the Sliding Guide Rods and Glide Frame

1. Slide the glide frame (38) along with four cushion collars (118) over the sliding guide rods (54).
2. Attach the sliding guide rods (54) to the main frame (34-2) with a total of four rubber bushings (75), four rod fixing rings (51), eight screws (84) and eight spring washers (96).
3. Screw the cable end (46) into the glide frame (38).

No.	Name	Specification	Qty.
34-2	Main frame		1
38	Glide frame		1
46	Cable set		1
51	Rod fixing ring	R29.5*21	4
54	Sliding guide rod	Φ25*1078	2
75	Rubber bushing	Φ36*Φ25*21	4
84	Hex socket head cap screw	M6*20	8
96	Spring washer	M6	8
118	Cushion collar		4

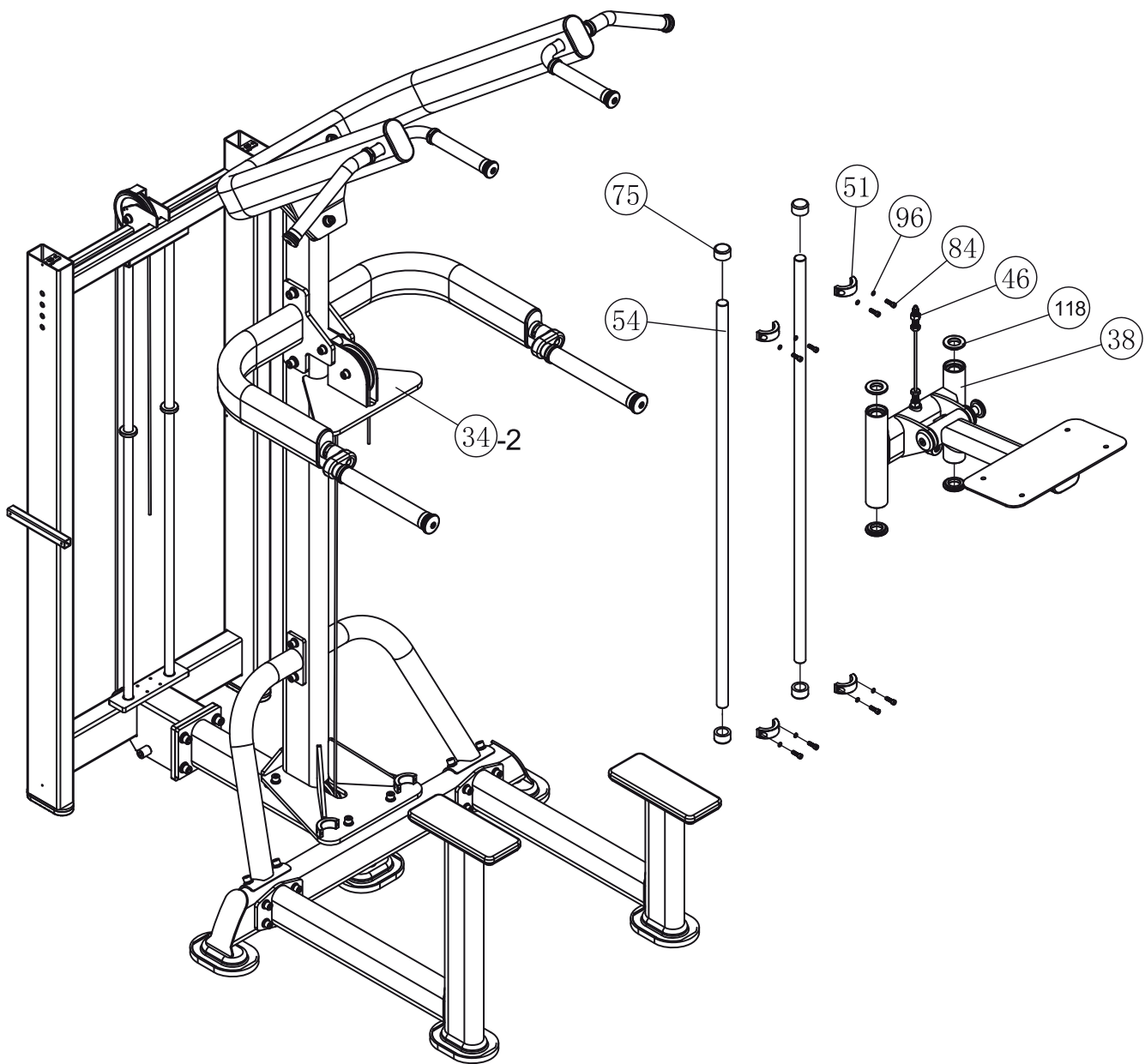



## Step 6: Assembly of Leg Pad Frame and Pad

Fix the leg pad (105) to the leg pad frame (39) with four screws (106), four spring washers (97) and four plain washers (100).

No.	Name	Specification	Qty.
39	Leg pad frame		1
97	Spring washer	M8	4
100	Plain washer	Φ16*Φ8.4*1.6	4
105	Leg pad		1
106	Hex socket head cap screw	M8*35	4

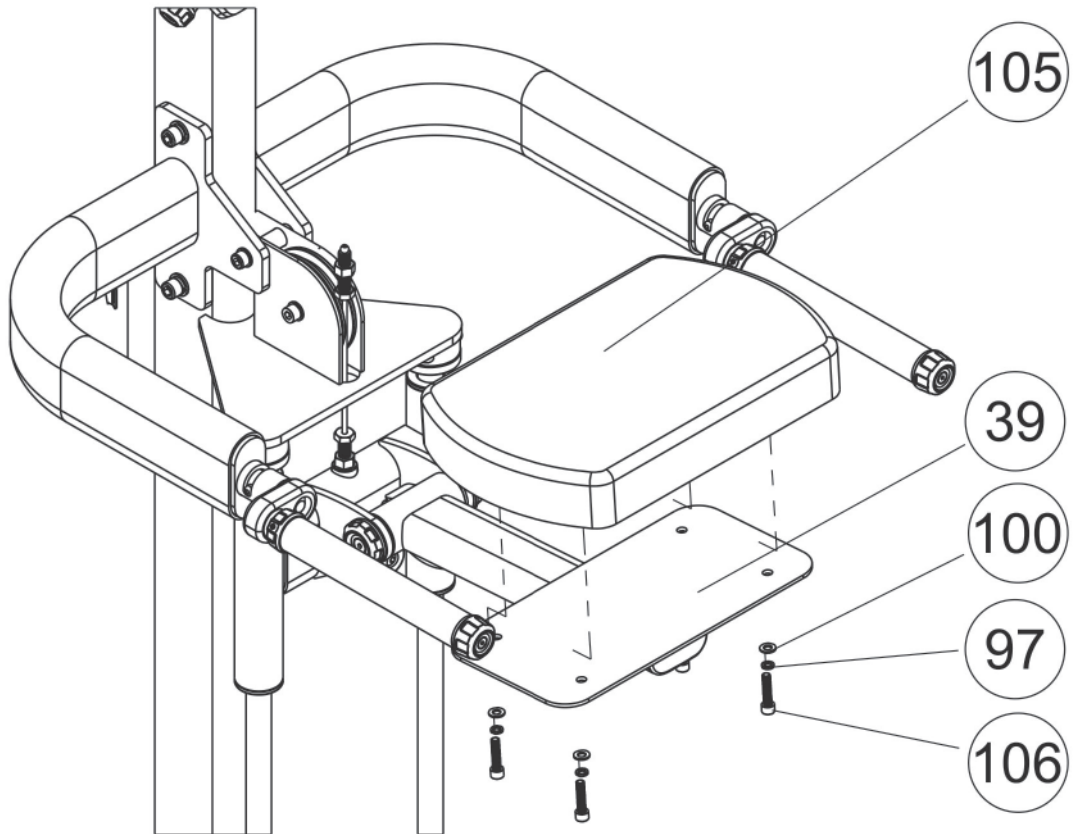

## Step 7: Assembly of the Weight Stack

### **NOTICE**

The guide rods are pre-assembled to the frame.

1. Disassemble the upper part of the guide rods (002) by removing the screws (021), the guide rod fixing sleeves (003), the split washers (028) and the bumpers (014).
2. Carefully slide each of the 20lb weight plates (61), followed by the 10 lb weight plates (60), over the guide rods (002) one by one.
3. Carefully slide the top weight plate incl. the counterweight (48) over the guide rods (002).
4. Insert the select pin set (020) into the weight stack.
5. Slide the previously removed bumpers (014) back over the guide rods (002).
6. Fix the guide rods (002) to the upper part of the frame (001) with the previously removed screws (021), guide rod fixing sleeves (003) and split washers (028).
7. Screw in the cable end (46) into the top weight plate (48).
8. Wipe the front surface of the weight stack.
9. Peel off the adhesive back sheet from the label and make sure the label remains attached to the application tape.
10. Align the center hole of the label with the weight stack center hole.
11. Line up the first label to the hole of the top plate.
12. Make sure the label is straight, then slowly press into place.
13. Gently remove the application tape and rub each label firmly against the weight stack.
14. Allow the labels to stand for at least 24 hours.

No.	Name	Specification	Qty.
002	Guide rod		2
003	Guide rod fixing sleeve		2
014	Bumper	Φ38*Φ21*10	2
020	Select pin set		1
021	Hex socket set screw with cone	M8*20	2
028	Split washer	d=20	2
48	10lb top weight		1
60	10lb weight stack plate	4.5 kg	3
61	20lb weight stack plate	9 kg	5

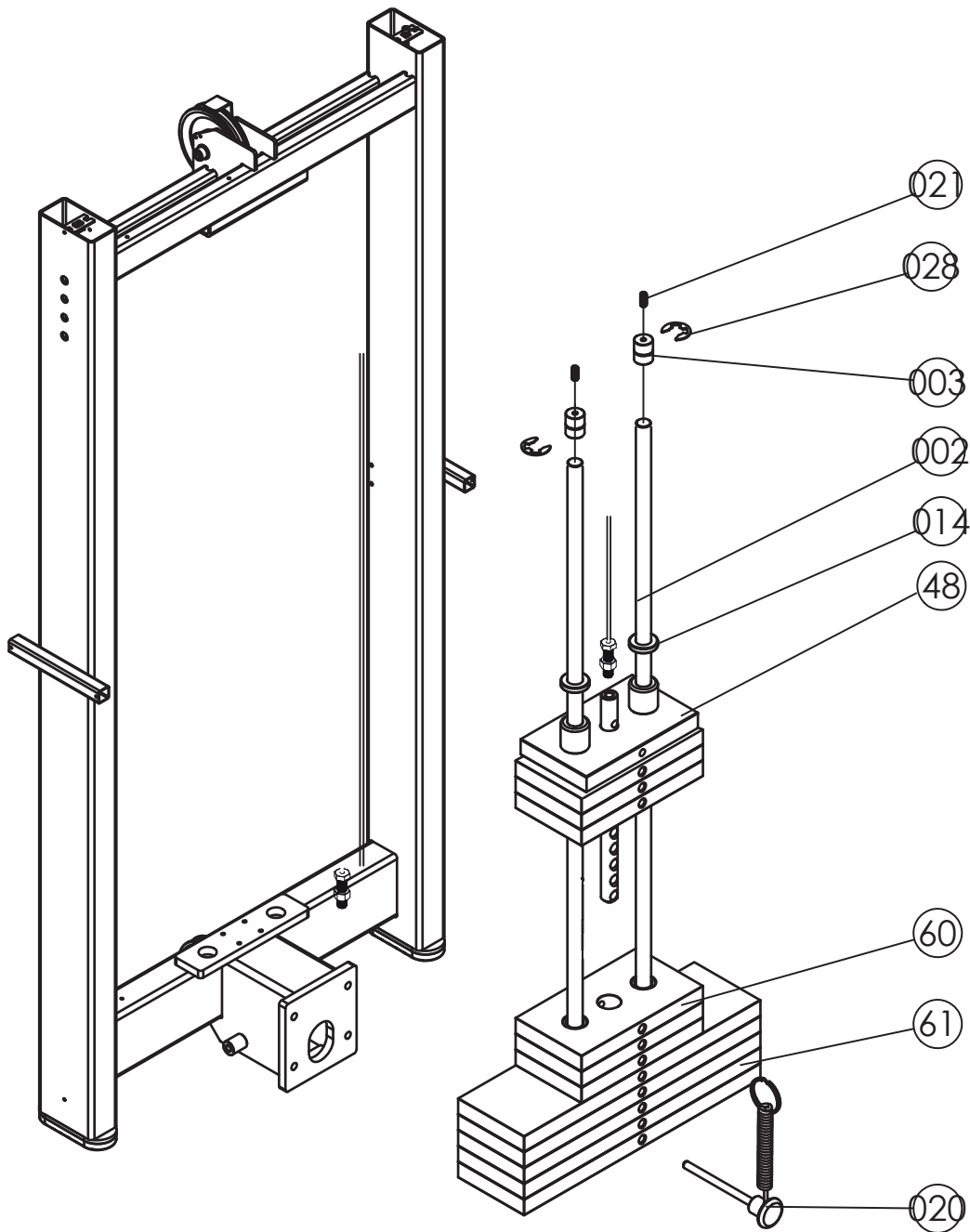

10 lbs	<input type="radio"/>	4.5 kg
20 lbs	<input type="radio"/>	9.1 kg
30 lbs	<input type="radio"/>	13.6 kg
40 lbs	<input type="radio"/>	18.1 kg
50 lbs	<input type="radio"/>	22.7 kg
70 lbs	<input type="radio"/>	31.8 kg
90 lbs	<input type="radio"/>	40.8 kg
110 lbs	<input type="radio"/>	49.9 kg
130 lbs	<input type="radio"/>	59 kg
150 lbs	<input type="radio"/>	68 kg

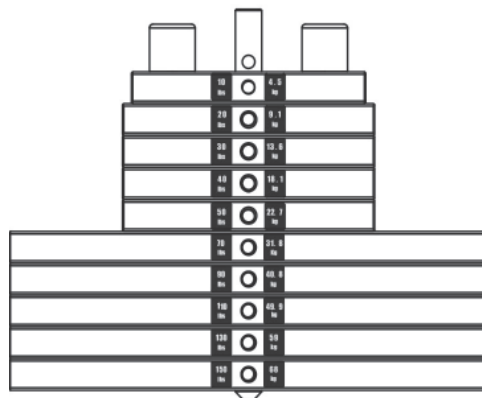

## Step 8: Assembly of the Shields and Trims

### ① NOTICE

The left and right shields are pre-assembled with a front or rear middle trim. Make sure to align the shields in the respective direction (front/rear).

1. Fix the left and right shields (005 & 006) with the rear and front middle trim (008 & 009) to the frame (001) with four screws (022).
2. Fix the side shields (007) to the frame (001) with four connecting strips (011) with twelve screws (022).
3. Fix the trays (010) to the frame (001) with two screws (024) and two flat washers (029).

→ *The assembly is completed.*

No.	Name	Specification	Qty.
005 + 008 + 006	Left shield + rear middle trim + right shield		1
005 + 009 + 006	Left shield + front middle trim + right shield		1
007	Side shield		2
010	Tray		2
011	Connecting strip		4
022	Cross recessed countersunk head screw	ST4.2*13	16
024	Hex socket countersunk head screw	M5*25	2
029	Flat washer	Φ10*Φ5.3*1	2

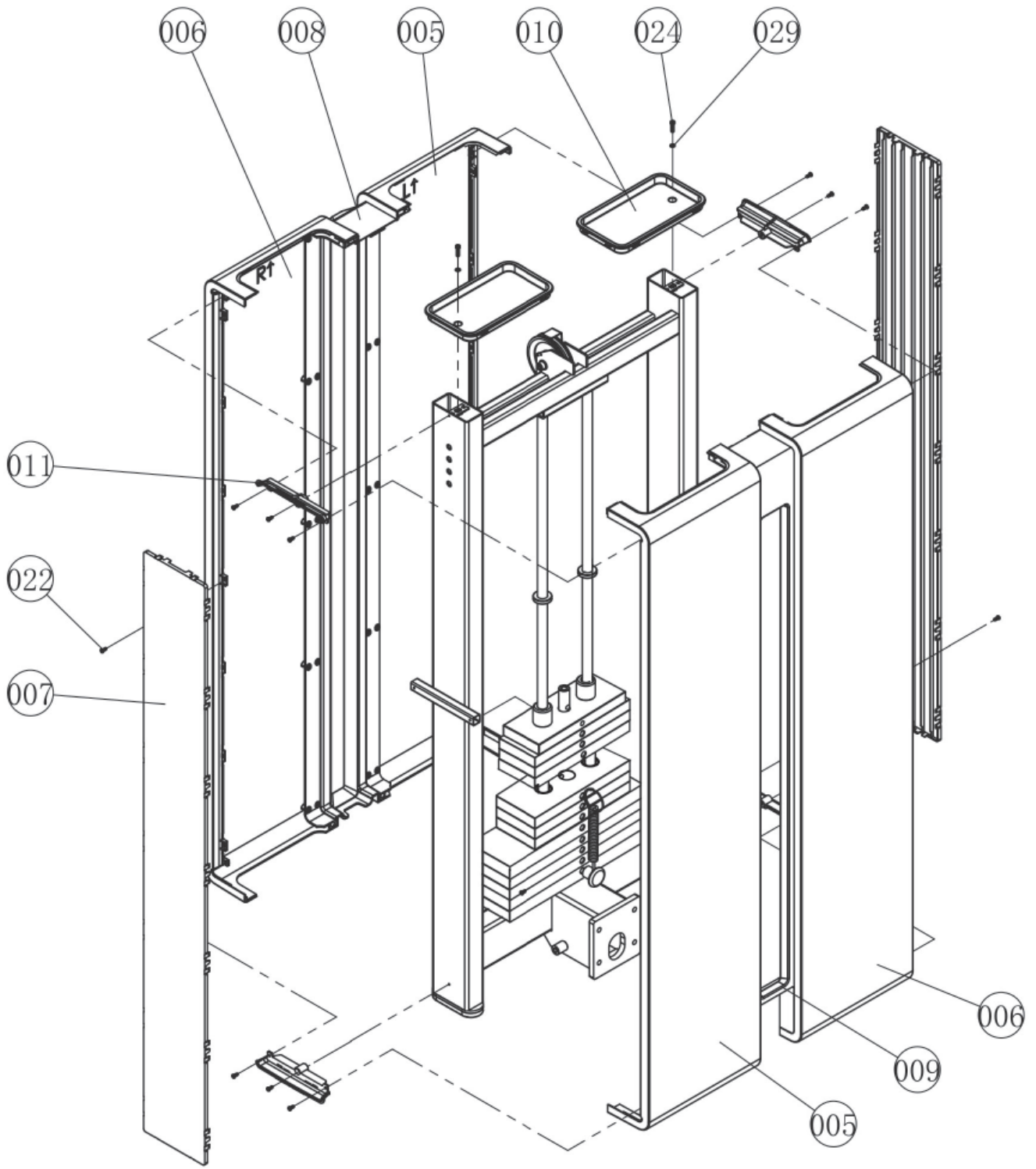

### 3.1 General Instructions



#### **WARNING**

- + The storage location should be chosen so that improper use by third parties or children can be prevented.
- + If your equipment does not have transportation wheels, the equipment must be disassembled before transportation.



#### **ATTENTION**

- + Make sure that the equipment is protected from moisture, dust and dirt in the selected storage location. The storage location should be dry and well ventilated and have a constant ambient temperature between 10°C and 35°C.

## 4.1 General Instructions



### WARNING

- + Do not make any improper changes to the equipment.



### CAUTION

- + Damaged or worn components may affect your safety and the life of the equipment. Therefore, immediately replace damaged or worn components. In such a case, contact the contract partner. The equipment must not be used until it has been repaired. If necessary, use only original spare parts.

### ATTENTION

- + In addition to the instructions and recommendations for maintenance and care given here, additional service and/or repair work may be necessary; this must only be carried out by authorised service technicians.

## 4.2 Faults and Fault Diagnosis

The equipment undergoes regular quality controls during production. Nevertheless, faults or malfunctions may occur. Frequently, individual parts are responsible for these disturbances, an exchange is usually sufficient. Please refer to the following overview for the most common errors and how to correct them. If the equipment still does not function properly, contact your contract partner.

Fault	Cause	Solution
Grinding noises	Cables or pulleys do not run smoothly or are damaged	+ Visual inspection of the cable routing or the pulley guide + If damaged, replace the defective part
Weight hanging in the air	Cable tensioned too tight	Readjust cable tension
Cable without tension	Cable too loose	+ Check cable routing + Readjust cable tension
Squeaking & cracking noises	Screw connections loosened or too tight	+ Check or lubricate screw connections* + Check cable routing
Unit wobbles	+ Uneven ground + Loose screw connections	+ Align unit + Tighten screw connections
Heavy draught	+ Weight holders/guide rods too dry + Faulty cable routing	+ Lubricate guide rods* + Check cable routing

\* With a grease-free silicone oil or silicone spray.



### 4.3 Maintenance and Inspection Calendar

To avoid damage from body sweat, the equipment must be cleaned with a damp towel (no solvents!) after each training session.

The following routine tasks must be performed at the specified intervals:

Part	Weekly	Monthly	Quarterly
Cables	C	I	
Screw connections		I	
Pulleys and cable routing		I	
Slide rails/Guide rods		I	
Cushions	C		
Legend: C = clean; I = inspect			

## 5 DISPOSAL

At the end of its operational life, this equipment cannot be disposed of in normal household waste. Instead, it must be disposed of via an recycling centre. Further information can be obtained from your local authority's recycling service.



The materials can be recycled as per their symbols. Through the reuse, recycling of materials or other forms of recovery of old equipment, you make an important contribution to the protection of the environment.

## 6 RECOMMENDED ACCESSORIES

To make your training experience even more efficient and pleasant, we recommend that you add suiting accessories to your fitness equipment. This could be a floor mat, for example, which makes your fitness equipment stand more securely and also protects the floor from falling sweat, but it could also be additional handrails on some treadmills or silicone spray to keep moving parts in good shape.

If you have purchased a fitness machine with pulse training and want to train your heart rate, we strongly recommend that you use a compatible chest strap, as this ensures optimum transmission of the heart rate. You may want to buy additional grips or weights for multi gyms.

Our range of accessories offers the highest quality and makes training even better. If you would like to find out more about compatible accessories, please go to the detail page of the product in our webshop (the easiest way is to enter the article number in the search field above) and go to the recommended accessories on this page. Of course, you can also contact our customer service: by telephone, e-mail, in one of our branches or via our social media channels. We will be happy to advise you!



floor mat



chest strap



towels

## 7.1 Serial Number and Model Name

In order to provide you with the best possible service, please have the model name, article number, serial number, exploded drawing and parts list ready. The corresponding contact options can be found in chapter 9 of this operating manual.

**NOTICE**

The serial number of your equipment is unique. It's located on a white sticker. The exact position of this sticker is shown in the following illustration.

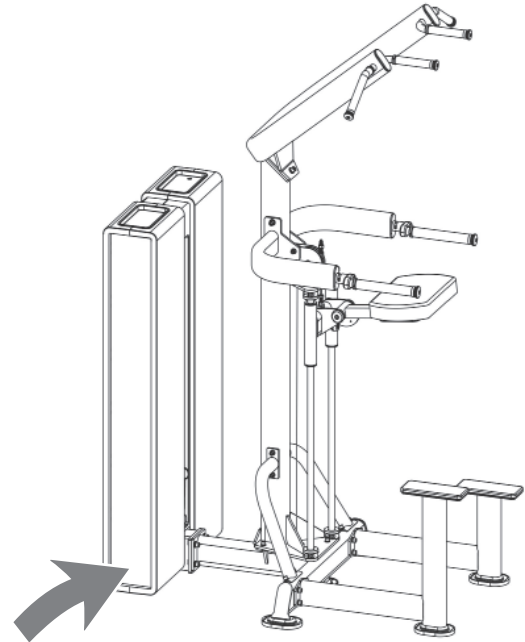

Enter the serial number in the appropriate field.

**Serial number:**

**Brand / Category:**

**Model Name:**

**SKU:**

## 7.2 Parts List

No.	Name	Specification	Qty.
001	Frame		1
002	Guide rod		2
003	Guide rod fixing sleeve		2
004	Pulley baffle		1
005	Left Shield		2
006	Right Shield		2
007	Side Shield		2
008	Rear middle Trim		1
009	Front middle Trim		1
010	Tay		2
011	Connecting strip		4
012	Pulley set	$\phi 89*25.8$	1
013	Pulley set	$\phi 114*32$	1
014	Bumper	$\phi 38*\phi 21*10$	2
015	Floor mat		2
016	Bumper	$\phi 62*\phi 20*26$	2
017	Guide rod upper cap		2
018	Hook stop collar		2
019	Single Side glue cushion	$25*35*3$	1
020	Select Pin Set		1
021	Hexagon Socket Set S with Cone	M8*20	2
022	Cross recessed countersunk head screw	ST4.2*13	56
023	Button Head Inner Hexagon Bolt	M8*16	4
024	Hexagon socket countersunk head screws	M5*25	2
025	Hexagon socket countersunk head screws	M10*50	1
026	Hexagon socket countersunk head screws	M10*60	1
027	Hexagon socket countersunk head screws	M12*30	4
028	Split Washer	d=20	2
029	Flat washer	$\Phi 10*\Phi 5.3*1$	2
030	Flat washer	$\Phi 16*\Phi 8.4*1.6$	4
031	Flat washer	$\Phi 20*\Phi 10.5*2$	4

032	Flat washer	Φ24*Φ13*2.5	4
033-1	Spring washer	M12	4
034-1	Nylon nut	M10	2
035-1	Nut	M5	2
036-1	Stopple	Φ10*Φ5.3*1	1
037-1	Elastic cylindrical pin	φ10*45	1
33-2	High foot frame		1
34-2	Main frame		1
35-2	Joint frame		1
36-2	Left parallel bars frame		1
37-2	Right parallel bars frame		1
38	Glide frame		1
39	Leg pad frame		1
40	Left bracket		1
41	Right bracket		1
42	Horizontal bar bracket		1
43	Short foot frame		1
44	Handle frame		2
45	Shaft		1
46	Cable set		1
47	Single hole paster		1
48	10lb top weight	4.5KG	1
49	Self-lubricating bearing	Φ28*Φ25*25	4
50	Block column	Φ10*26	2
51	Rod fixing ring	R29.5*21	4
52	Linear bearing	Φ40*Φ25*59	4
53	Self-lubricating bearing	Φ28*Φ25*16.5	2
54	Sliding guide rod	Φ25*1078	2
55	M20 nut	M20*1.5*16	1
56	Spring	Φ1.4*Φ12.5*70	1
57	Pilot plunger	Φ16*Φ10*112*M10	1
58	15holes shaft	Φ22*438	1
59	10lb weight stack plate	4.5KG	1
60	10lb weight stack plate	4.5KG	11
61	20lb weight stack plate	9KG	2

62	Circlips for hole	Φ40	4
63	Circlips for shaft	d0=25	2
65	Pulley	Φ114*25.4	2
66	Rubber foot	180*120*16	5
67	Handle grip	Φ37.5*Φ31*240	2
68	Rubber bumper	25*25*4.6	1
69	Foot plate rubber sheet	260*105*18	2
71	Rubber cushion	Φ38*Φ33*15	1
73	Handle grip	Φ25*150	2
74	Elliptical tube stopper	PT40*80*3	1
75	rubber bushing	Φ36*Φ25*21	4
76	Rotary knob	Φ41*30.5*M10	1
78	Aluminum end cover	Φ50*15	2
79	Handle grip	Φ25*240	2
80	Elliptical tube stopper	PT50*100*3	2
83	Hexagon socket button head screw	M8*15	1
84	Hex socket head cap screw	M6*20	8
85	Hex socket head cap screw	M8*15	4
86	Hex socket head cap screw	M10*25	24
87	Hex socket head cap screw	M10*50	1
88	Hex socket head cap screw	M10*65	1
89	Hex socket head cap screw	M10*85	1
90	Hex socket head cap screw	M12*30	5
91	Hex socket head cap screw	M12*90	2
92	Cross recessed countersunk head screw	M5*10	2
94	Countersunk hex socket screws	M8*20	2
96	Spring washer	M6	8
97	Spring washer	M8	9
98	Spring washer	M10	24
99	Spring washer	M12	5
100	Plain washer	Φ16*Φ8.4*1.6	9
101	Plain washer	Φ20*Φ10.5*2	26
102	Plain washer	Φ24*Φ13*2.5	9
103	Nylon insert lock nut	M10	3
104	Nylon insert lock nut	M12	2

105	Leg pad		1
106	Hex socket head cap screw	M8*35	4
107	10lb weight stack plate	4.5KG	1
108	Aluminum ring	Φ42*Φ33*13	2
109	Aluminum ring	Φ39*Φ30*14.5	2
110	Plastic ring	Φ37*Φ33*4.5	2
111	Aluminum end cover	Φ45*Φ6.5*14	2
112	Hex socket head cap screw	M6*25	6
113	hexagon socket set screw with cone point	M5*5	12
114	Aluminum end cover	Φ38*Φ6.5*13	4
115	Plastic ring	Φ30*Φ26*4.5	4
116	Aluminum ring	Φ32*Φ23*14.5	4
117	Aluminum ring	Φ35*Φ26*13	4
118	Cushion collar		4

### 7.3 Exploded Drawing

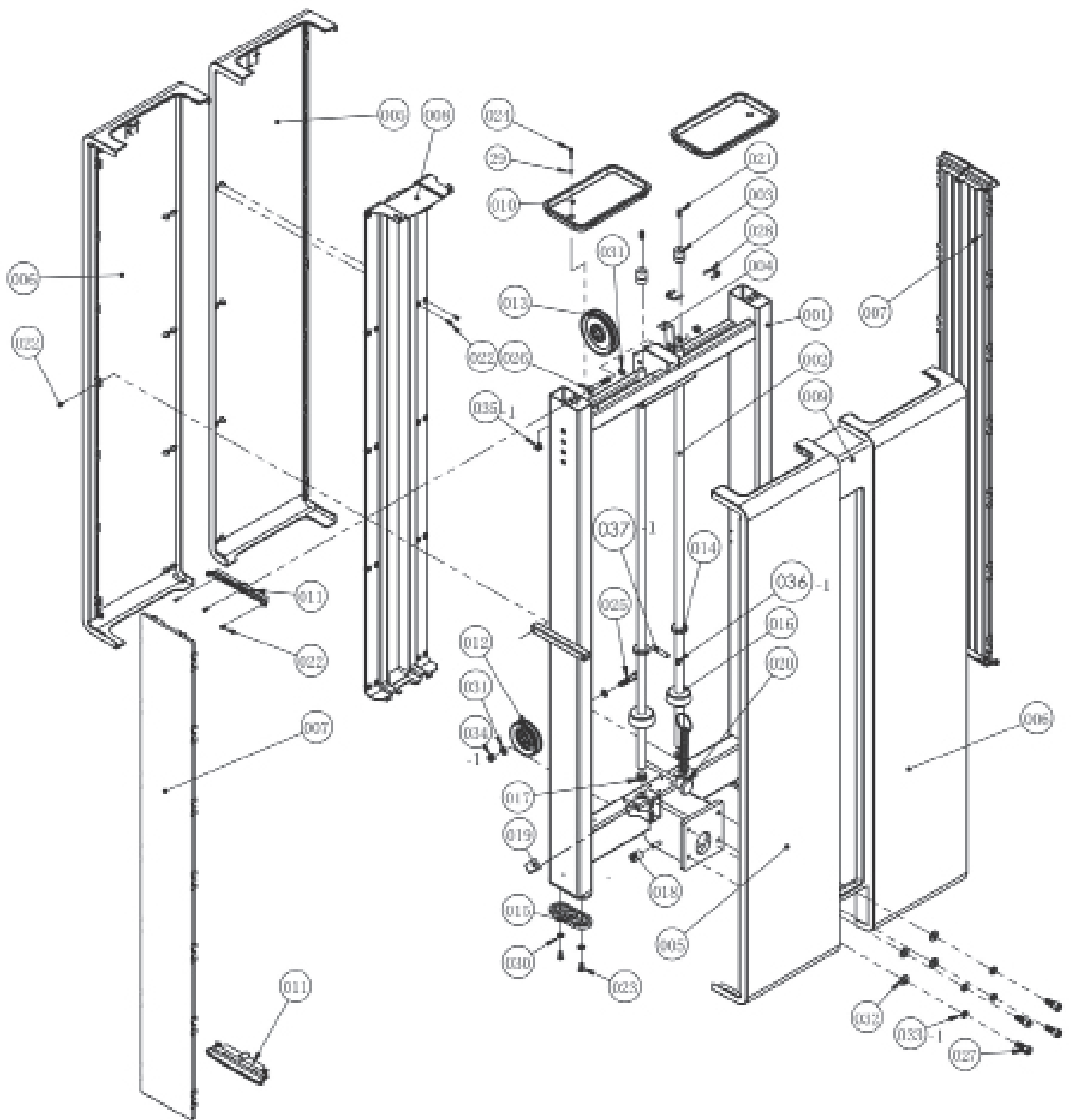



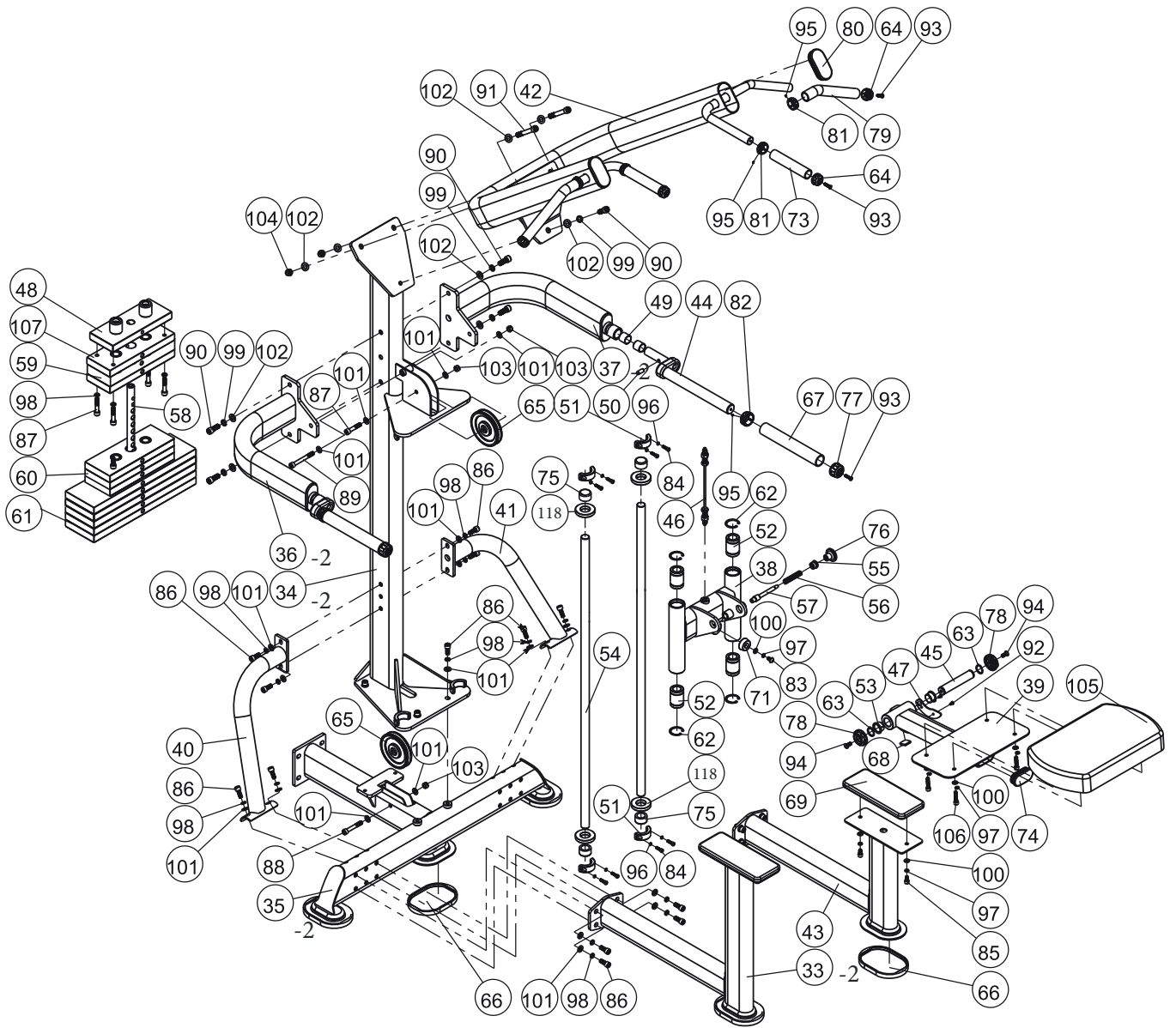

Products from TAURUS® are subject to strict quality control. However, if a fitness equipment purchased from us does not work perfectly, we take it very seriously and ask you to contact our customer service as indicated. We are happy to help you by phone via our service hotline.

### **Error Descriptions**

Your fitness equipment is developed for long-term, high-quality training. However, should a problem arise, please first read the operating instructions. For further assistance, please contact your contract partner or call our service hotline. To ensure your problem is solved as quickly as possible, please describe the defect as exactly as possible.

In addition to the statutory warranty, we provide a warranty for every fitness equipment purchased from us according to the following provisions.

**Your statutory rights are not affected.**

### **Warranty**

The warranty is the first/original buyer.

### **Warranty periods**

The following warranty periods begin on delivery of the fitness equipment.

#### **Warranty period**

The warranty periods, shown on our web shop, begin on delivery of the fitness equipment. The respective warranty periods for your equipment can be found on its product website.

### **Repair Costs**

According to our choice, there will either be a repair, a replacement of individual damaged parts or a complete replacement. Spare parts, that have to be mounted while assembling the equipment, have to be replaced by the warranty holder personally and are not a part of repair. After the expiration of the warranty period, the responsibility for parts costs, repair costs, installation costs and delivery costs lies with the warranty holder.

### **The terms of use are defined as follows:**

- + Home use: solely for private use in private households up to 3 hours per day
- + Semi-professional use: up to 6 hours per day (e. g. rehabilitation centres, hotels, clubs, company gyms)
- + Professional use: more than 6 hours per day (e. g. commercial gyms)

## **Warranty Service**

Within the warranty period, equipment which develops faults as a result of material or manufacturing defects, will be repaired or replaced at our discretion. Ownership of equipment or parts of equipment which have been replaced is transferred to us. The warranty period is not extended nor does a new warranty period begin following repair or replacement under the warranty.

## **Warranty Conditions**

For the warranty to be valid, the following steps must be taken:

Please contact our customer service by email or phone. If the product under warranty has to be sent in for repair, the seller bears costs. After expiry of the warranty, the buyer bears the costs of transport and insurance. If the fault is covered by our warranty, you will receive a new or repaired equipment in return.

## **Warranty claims are invalid in case of damage resulting from:**

- + misuse or improper handling
- + environmental influences (moisture, heat, electrical surge, dust, etc.)
- + failure to follow the current safety measures for the equipment
- + failure to follow the operating instructions
- + use of force (e. g. hitting, kicking, falling)
- + interventions which were not carried out by one of our authorized service centres
- + unauthorised repair attempts

## **Proof of Purchase and Serial Number**

Please make sure that you are able to provide the appropriate receipt when claiming on your warranty. So that we can clearly identify the model of your equipment, and for the purposes of our quality control, you will need to give the serial number of your equipment, when contacting the service team. Where possible please have your serial number and your customer number ready when you call our service hotline. It will help us to deal with your request swiftly.

If you cannot find the serial number on your fitness equipment, our service team is at your disposal to offer further information.

## **Service outside of the Warranty Period**

We are also happy to issue an individual cost estimate if there is a problem with your fitness equipment after the warranty has expired, or in cases which do not fall under the terms of the warranty, e. g. normal wear and tear. Please contact our customer service team to find a quick and cost-effective solution to your problem. In such a case you will be responsible for the delivery costs.

## **Communication**

Many problems can be solved just by speaking to us as your specialist supplier. We know how important it is to you as a user of the fitness equipment to have problems solved quickly and simply, so you can enjoy working out with minimal interruption. For that reason, we also want to resolve your queries quickly and in a straightforward manner. Thus, please always keep your customer number and the serial number of the faulty equipment handy.

## 9 CONTACT

DE	DK	UK
<p><b>TECHNIK</b></p> <p>☎ +49 4621 4210-900 ☎ +49 4621 4210-698 ✉ technik@fitshop.de 🕒 Öffnungszeiten entnehmen Sie unserer Homepage.</p> <p><b>SERVICE</b></p> <p>☎ 0800 20 20277 (kostenlos) ☎ 04621 4210 - 0 ✉ info@fitshop.de 🕒 Öffnungszeiten entnehmen Sie unserer Homepage: <a href="https://stg.fit/statita">https://stg.fit/statita</a></p>	<p><b>TEKNIK OG SERVICE</b></p> <p>☎ 80 90 16 50 ☎ +49 4621 4210-945 ✉ info@fitshop.dk 🕒 Åbningstider kan findes på hjemmesiden: <a href="https://stg.fit/statit7">https://stg.fit/statit7</a></p>	<p><b>CUSTOMER CARE</b></p> <p>☎ +44 141 737 2249 or +44 141 876 3972 ✉ customercare@fitshop.co.uk 🕒 You can find the opening hours on our homepage: <a href="https://stg.fit/statitd">https://stg.fit/statitd</a></p>
	FR	BE
	<p><b>TECHNIQUE &amp; SERVICE</b></p> <p>☎ +33 (0) 189 530984 ☎ +49 4621 42 10 933 ✉ info@fitshop.fr 🕒 Vous trouverez les heures d'ouverture sur notre site Internet: <a href="https://stg.fit/statit4">https://stg.fit/statit4</a></p>	<p><b>TECHNIQUE &amp; SERVICE</b></p> <p>☎ 02 732 46 77 ☎ +49 4621 4210 933 ✉ info@fitshop.be 🕒 Vous trouverez les heures d'ouverture sur notre site Internet: <a href="https://stg.fit/statit8">https://stg.fit/statit8</a></p>
ES	NL	INT
<p><b>TECNOLOGÍA Y SERVICIOS</b></p> <p>☎ 911 238 029 ✉ info@fitshop.es 🕒 Consulta nuestro horario de apertura en la página web: <a href="https://stg.fit/statit5">https://stg.fit/statit5</a></p>	<p><b>TECHNISCHE DIENST &amp; SERVICE</b></p> <p>☎ +31 172 619961 ✉ service@fitshop.nl 🕒 De openingstijden vindt u op onze homepage: <a href="https://stg.fit/statit3">https://stg.fit/statit3</a></p>	<p><b>TECHNICAL SUPPORT &amp; SERVICE</b></p> <p>☎ +49 4621 4210-944 ✉ service-int@fitshop.de 🕒 You can find the opening hours on our homepage: <a href="https://stg.fit/statita">https://stg.fit/statita</a></p>
PL	AT	CH
<p><b>DZIAŁ TECHNICZNY I SERWIS</b></p> <p>☎ 22 307 43 21 ☎ +49 4621 42 10-948 ✉ info@fitshop.pl 🕒 Godziny otwarcia można znaleźć na stronie głównej: <a href="https://stg.fit/statit6">https://stg.fit/statit6</a></p>	<p><b>TECHNIK &amp; SERVICE</b></p> <p>☎ 0800 20 20277 (Freecall) ☎ +49 4621 42 10-0 ✉ info@fitshop.at 🕒 Öffnungszeiten entnehmen Sie unserer Homepage: <a href="https://stg.fit/statitb">https://stg.fit/statitb</a></p>	<p><b>TECHNIK &amp; SERVICE</b></p> <p>☎ 0800 202 027 ☎ +49 4621 42 10-0 ✉ info@fitshop.ch 🕒 Öffnungszeiten entnehmen Sie unserer Homepage: <a href="https://stg.fit/statit9">https://stg.fit/statit9</a></p>

Please find a detailed overview including address and opening hours for all stores of Fitshop UK on the following website:

[www.fitshop.co.uk/storelocator](http://www.fitshop.co.uk/storelocator)

# WE LIVE FITNESS

## WEBSHOP AND SOCIAL MEDIA

The Fitshop Group is Europe's largest specialist for home fitness equipment with currently 70 stores and one of the world's most renowned online mail order companies for fitness equipment.

Fitshop UK is part of the Fitshop Group. Private customers order via the 25 web shops in the respective national language or have their desired equipment assembled on site. In addition, the company supplies fitness studios, hotels, sports clubs, companies and physio practices with professional equipment for endurance and strength training.

The Fitshop group offers a wide range of fitness equipment from renowned manufacturers, high-quality in-house developments and comprehensive services, such as a build-up service and sports scientific advice before and after the purchase. The company employs numerous sports scientists, fitness trainers and competitive athletes.

Visit us also on our social media platforms or our blog!

	<a href="https://www.fitshop.co.uk/">https://www.fitshop.co.uk/</a> <a href="http://www.fitshop.co.uk/blog/">www.fitshop.co.uk/blog/</a>
	<a href="http://www.facebook.com/fitshop.co.uk">www.facebook.com/fitshop.co.uk</a>
	<a href="http://www.instagram.com/fitshop_uk">www.instagram.com/fitshop_uk</a>
	<a href="http://www.youtube.com/@fitshop_uk">www.youtube.com/@fitshop_uk</a>

**TAURUS**

 cardiostrong

*BODYCRAFT*

**BodyMax**

Notes



# **TAURUS<sup>®</sup>**

**Dual Pro Assisted Chin & Dip**