

TAURUS®

Owner's Manual

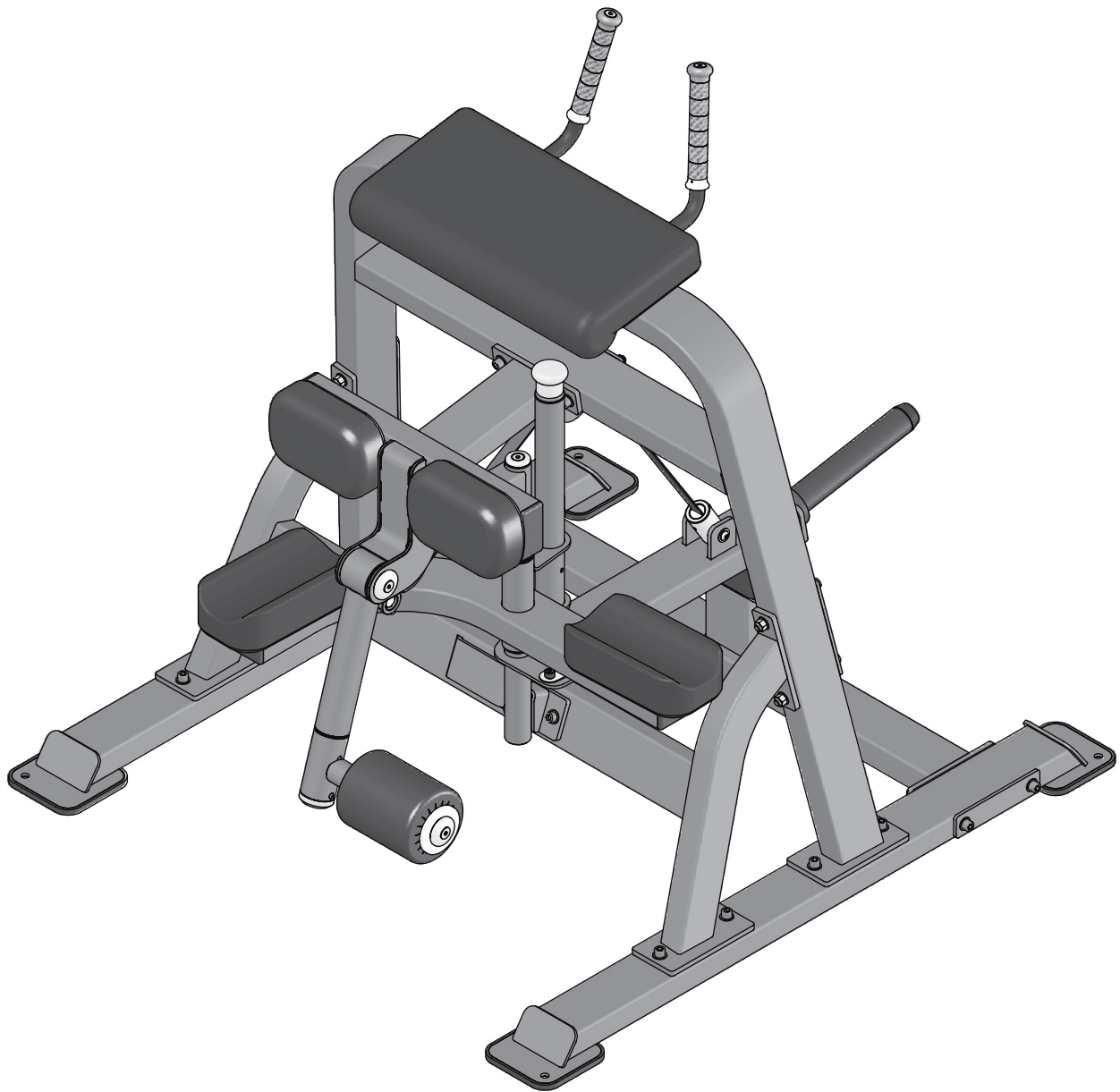

TF-SL7026

ISO LEG CURL STERLING

TAURUS® is a registered brand of the company Sport-Tiedje GmbH.
All rights reserved. Any use of this trademark without the explicit written permission of Sport-Tiedje is prohibited.

! CAUTION

Read all precautions and instructions in this manual before using this equipment.

Table Of Contents

Important Safety Instructions-----	3
Instructions-----	5
Parts List and Exploded View-----	6
Measurement Guide-----	19
Assembly Instructions-----	20
Assembly-----	21
Adjust Instructions-----	28
Exercise Instructions-----	29
Maintenance Schedule-----	30
General Maintenance Information-----	31
Weight Training Tips-----	32

Important Safety Instructions

Before beginning any fitness program, you should obtain a complete physical examination from your physician. When using exercise equipment, basic precautions should always be taken, including the following:

1. Read all instructions before using the equipment.
These instructions are written to ensure your safety and to protect the unit.
2. Use the equipment only for its intended purpose as described in this guide.
Do not use accessory attachments that are not recommended by the manufacturer: such attachments might cause injuries.
3. The product should only be used on a level surface and is with 0.5 meters space around the product.
Do not use the equipment outdoors.
4. Do not allow children on or near the equipment. And children are not allowed to use this equipment.
Teenagers should use this equipment with adult supervision.
5. Do not overexert yourself or work to exhaustion.
Do not attempt to lift more weight than you can control safely.
If you feel any pain or abnormal symptoms, stop your workout immediately and consult your physician.
6. This equipment is not used as medical apparatus and instruments.
7. Never operate the unit when it has been dropped or damaged.
Never drop or insert anything into any opening in the equipment.
Always check the unit and its cables before each use. Make sure that all fasteners and cables are secure and in good working condition.
Frayed or worn cables can be dangerous and may cause injury. Periodically check these cables for any indication of wear.
Keep hands, limbs, loose clothing and long hair well out of the way of moving parts.
8. Be careful when getting on or off the equipment.
9. Wear proper exercise clothing and shoes for your workout, no loose clothing.

Important Safety Instructions

Personal Safety During Assembly

Read each step in the assembly instructions and follow the steps in sequence. Do not skip ahead. If you skip ahead, you may learn later that you have to disassemble components and that you may have damaged the equipment.

Assemble and operate the equipment on a solid, level surface. Locate the unit a few feet from walls or furniture to provide easy access. The equipment is designed for your enjoyment. By following these precautions and using common sense, you will have many safe and pleasurable hours of healthful exercise with the equipment.

Training Area and Free Area

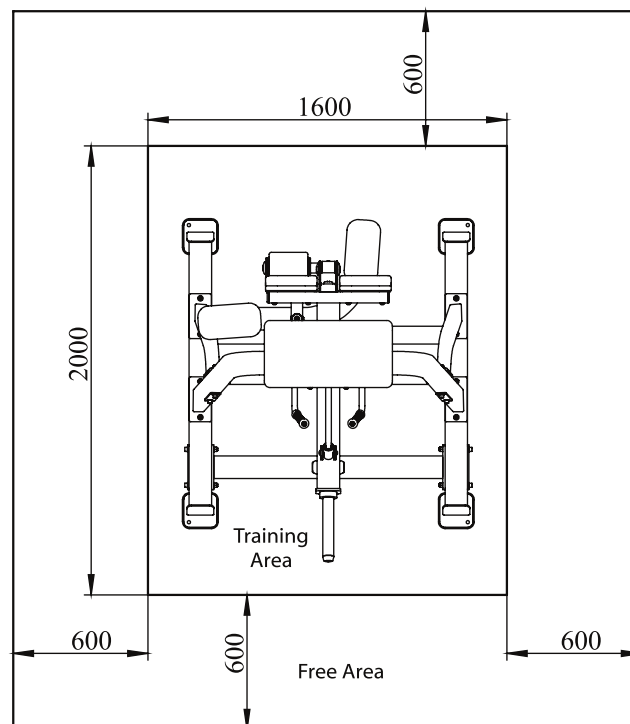

Specifications

Class: S

Maximum Wt. Capacity: 120kg/ 265lbs

Maximum User Weight: 150kg/ 330lbs

Product Total Surface: 1403*1045mm

Product Total Mass: 136.1kg/ 300lbs

Instructions

Before beginning assembly please take the time to read instructions thoroughly. Please use the various lists in this manual to make sure that all parts have been included in your shipment. When ordering, use part number and description from the lists. Use only our replacement part when servicing. Failure to do so will void your warranty and could result in personal injury.

The equipment is designed to provide the smoothest, most effective exercise motion possible. After assembly, you should check all functions to ensure correct operation. If you experience problems, first recheck the assembly instructions to locate any possible errors made during assembly. If you are unable to correct the problem, call your authorized dealer. Be sure to have your serial number and this manual when calling. When all parts have been accounted for, continue on.

Tools Required

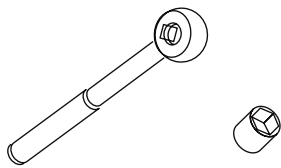

Ratchet Wrench and Socket

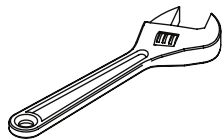

Adjustable Wrench

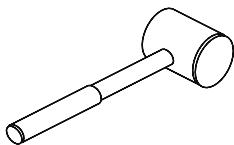

Rubber Mallet

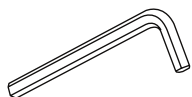

Hex Key Wrench Set

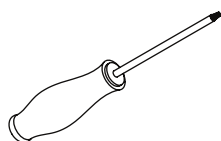

Phillips Screwdriver

Exploded View and Parts List

Left Bottom Frame ASSY

ITEM NO.	Description	QTY
1	Left Bottom Frame	1
2	Rubber Foot	2

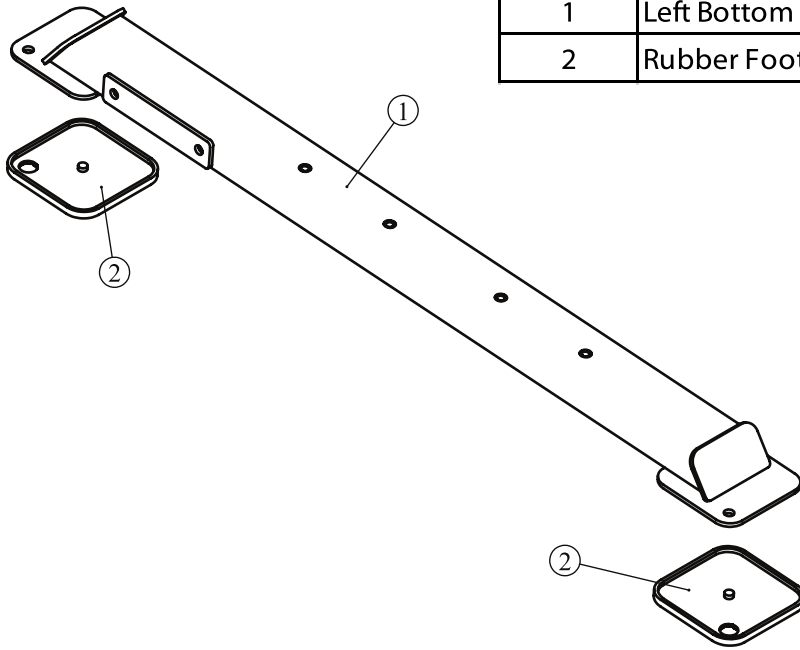

Right Bottom Frame ASSY

ITEM NO.	Description	QTY
1	Right Bottom Frame	1
2	Rubber Foot	2

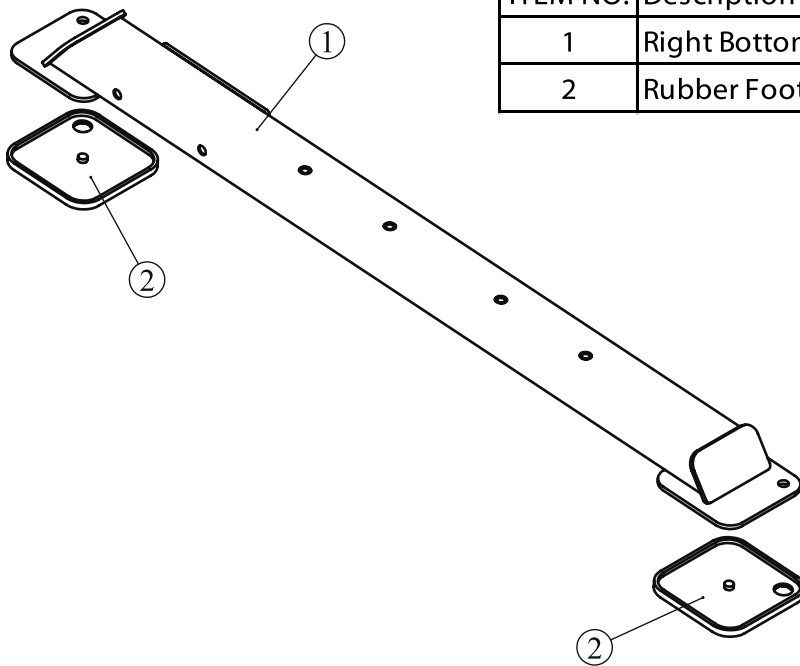

Exploded View and Parts List

Standing Frame ASSY

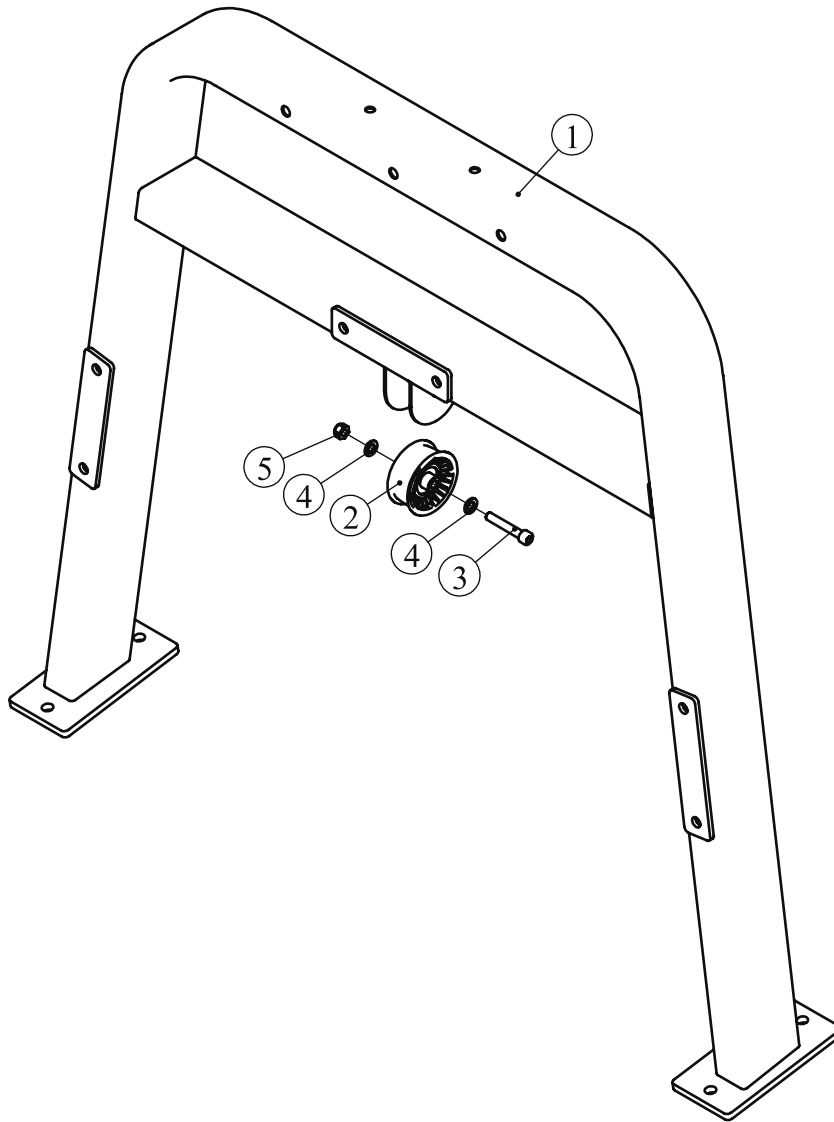

ITEM NO.	Description	QTY
1	Standing Frame	1
2	Pulley $\Phi 76$	1
3	Socket Head Cap Screw M10*60	1
4	Flat Washer $\Phi 11 * \phi 20 * 2$	2
5	Nylon Nut M10	1

Exploded View and Parts List

Up Support Frame ASSY

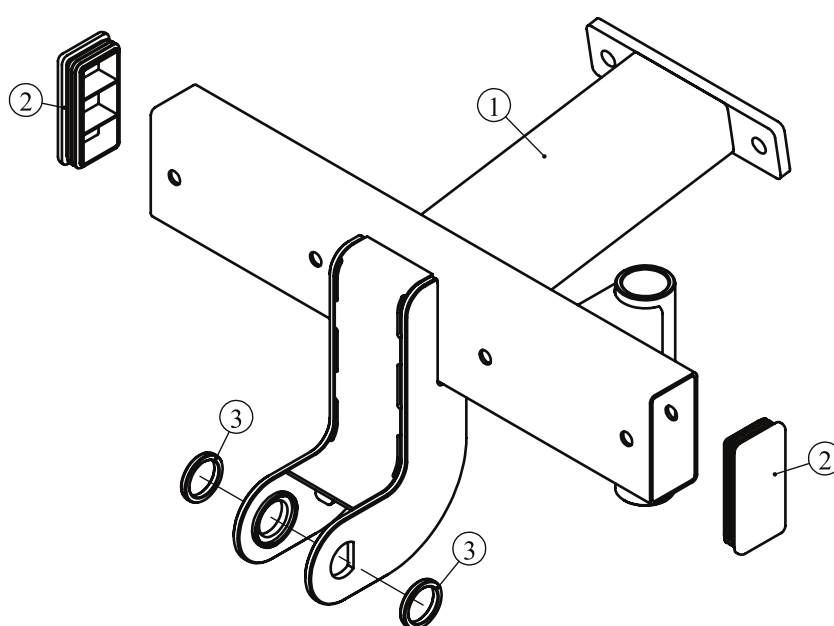

ITEM NO.	Description	QTY
1	Up Support Frame	1
2	End Cap 50*100	2
3	The Spacer Φ 40	2

Exploded View and Parts List

Rotating Frame ASSY

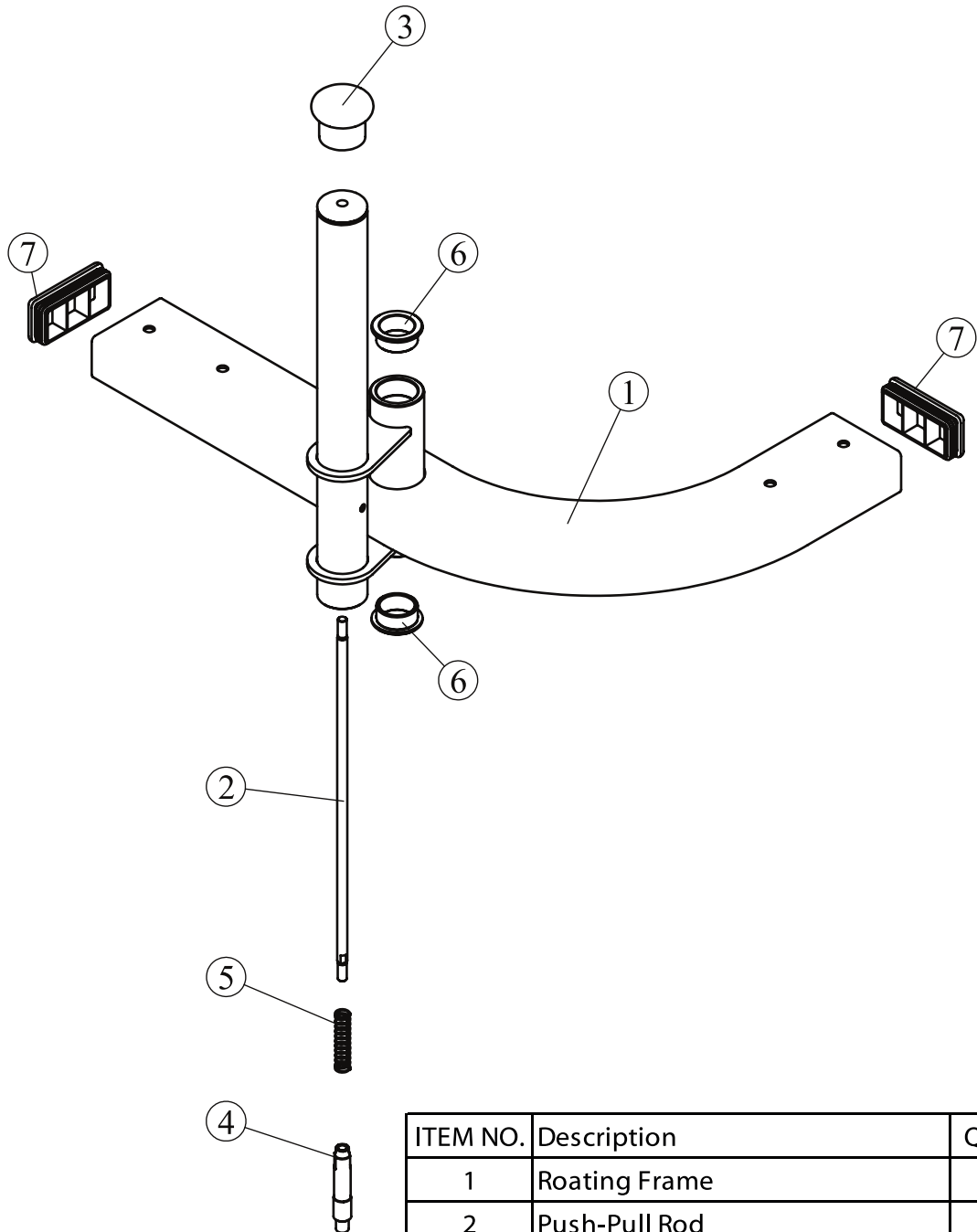

ITEM NO.	Description	QTY
1	Roating Frame	1
2	Push-Pull Rod	1
3	Knop	1
4	Pin	1
5	Spring Φ 13	1
6	Bushing Φ 35	2
7	End Cap 50*100	2

Exploded View and Parts List

Bracket Frame ASSY

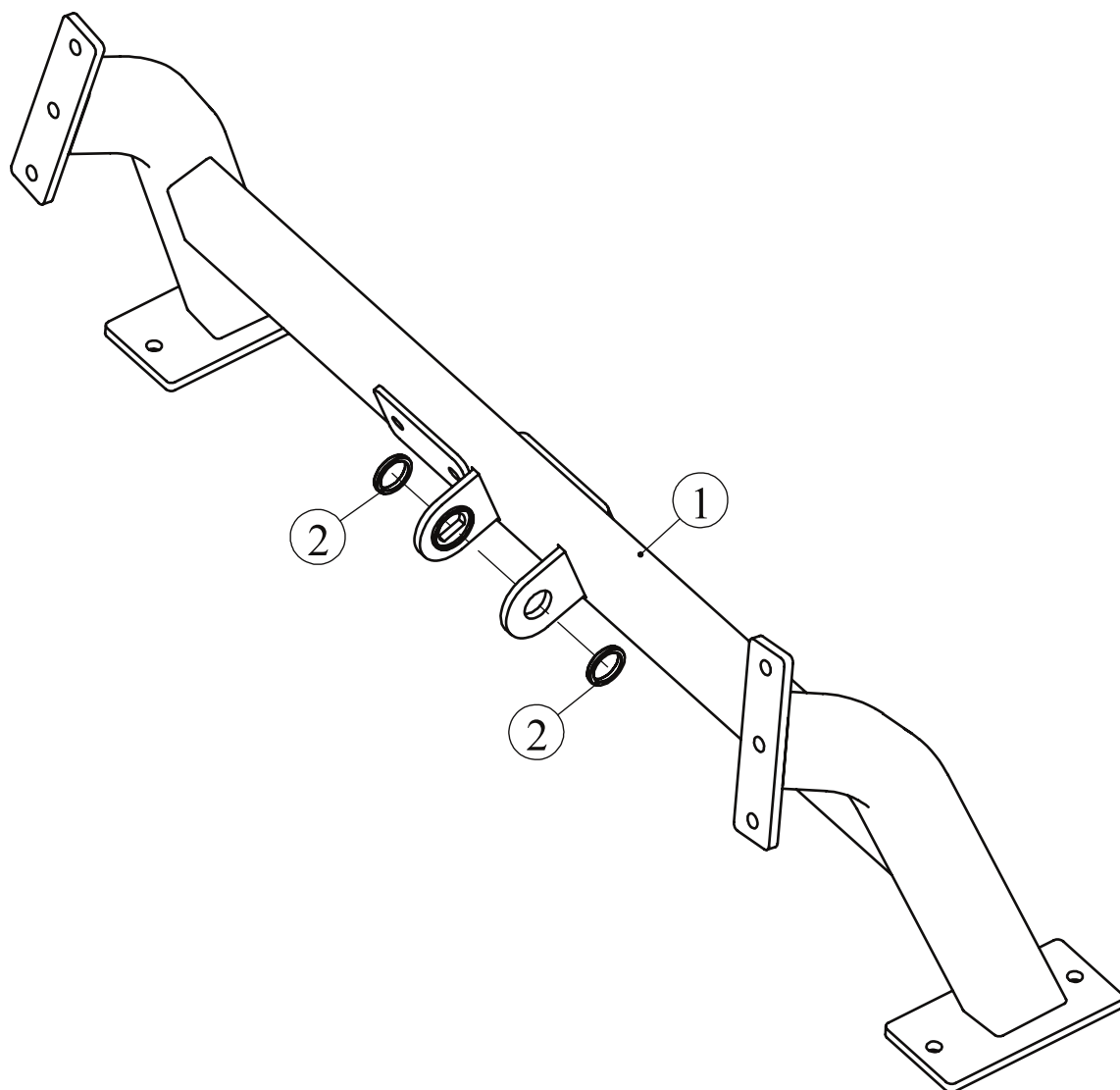

ITEM NO.	Description	QTY
1	Bracket Frame ASSY	1
2	The Spacer $\Phi 40$	2

Exploded View and Parts List

Support Frame ASSY

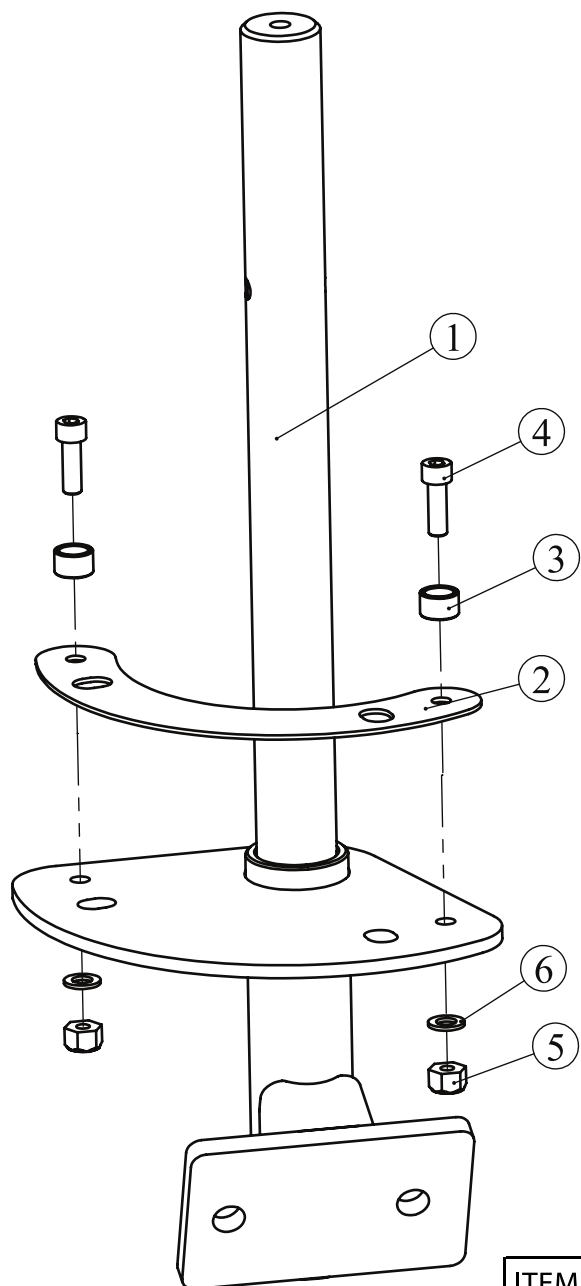

ITEM NO.	Description	QTY
1	Support Frame	1
2	Scaleboard	1
3	Spacer	2
4	Socket Head Cap Screw M8*25	2
5	Nylon Nut M8	2
6	Flat Washer $\Phi 9*\Phi 16*1.6$	2

Exploded View and Parts List

Cross Frame ASSY

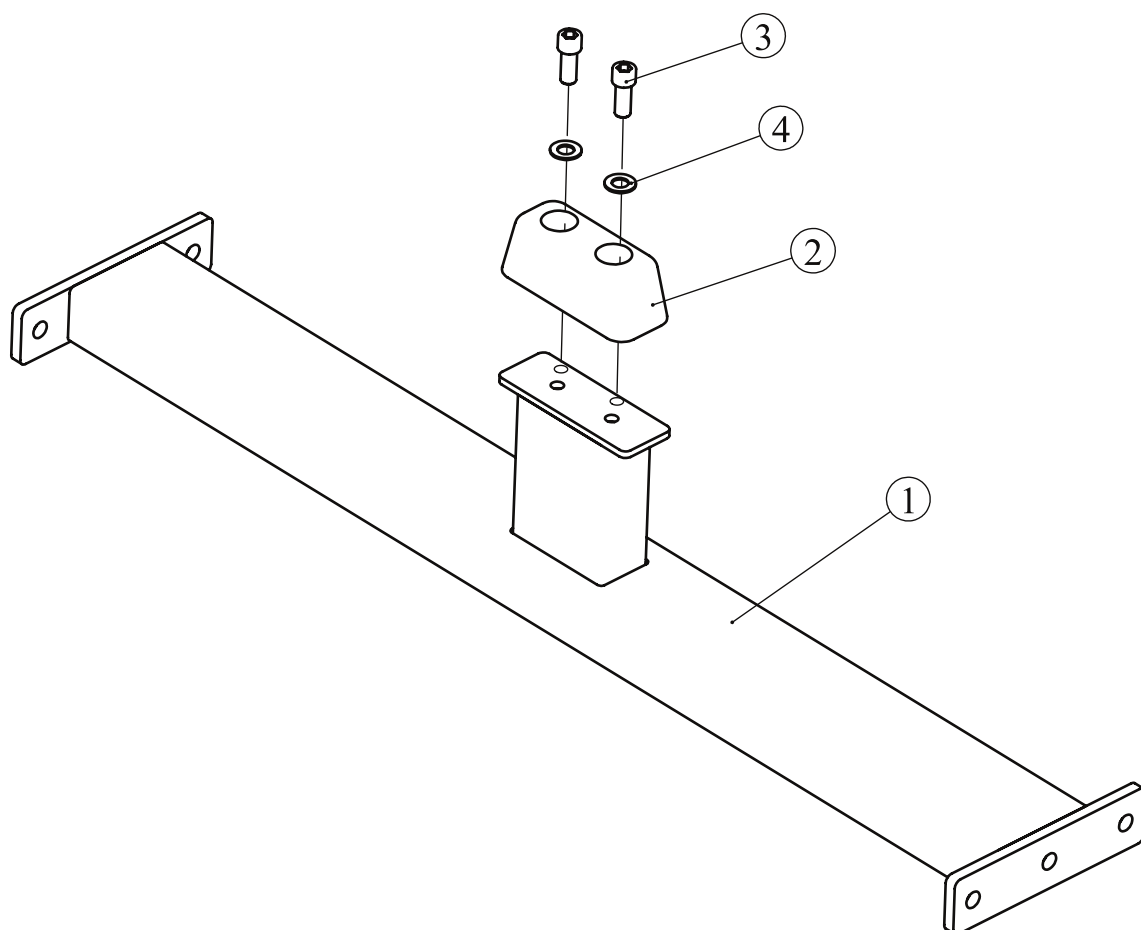

ITEM NO.	Description	QTY
1	Cross Frame	1
2	Large Rubber Bumper	1
3	Socket Head Cap Screw M12*30	2
4	Flat Washer $\Phi 13*\Phi 24*1.5$	2

Exploded View and Parts List

Handle Frame ASSY

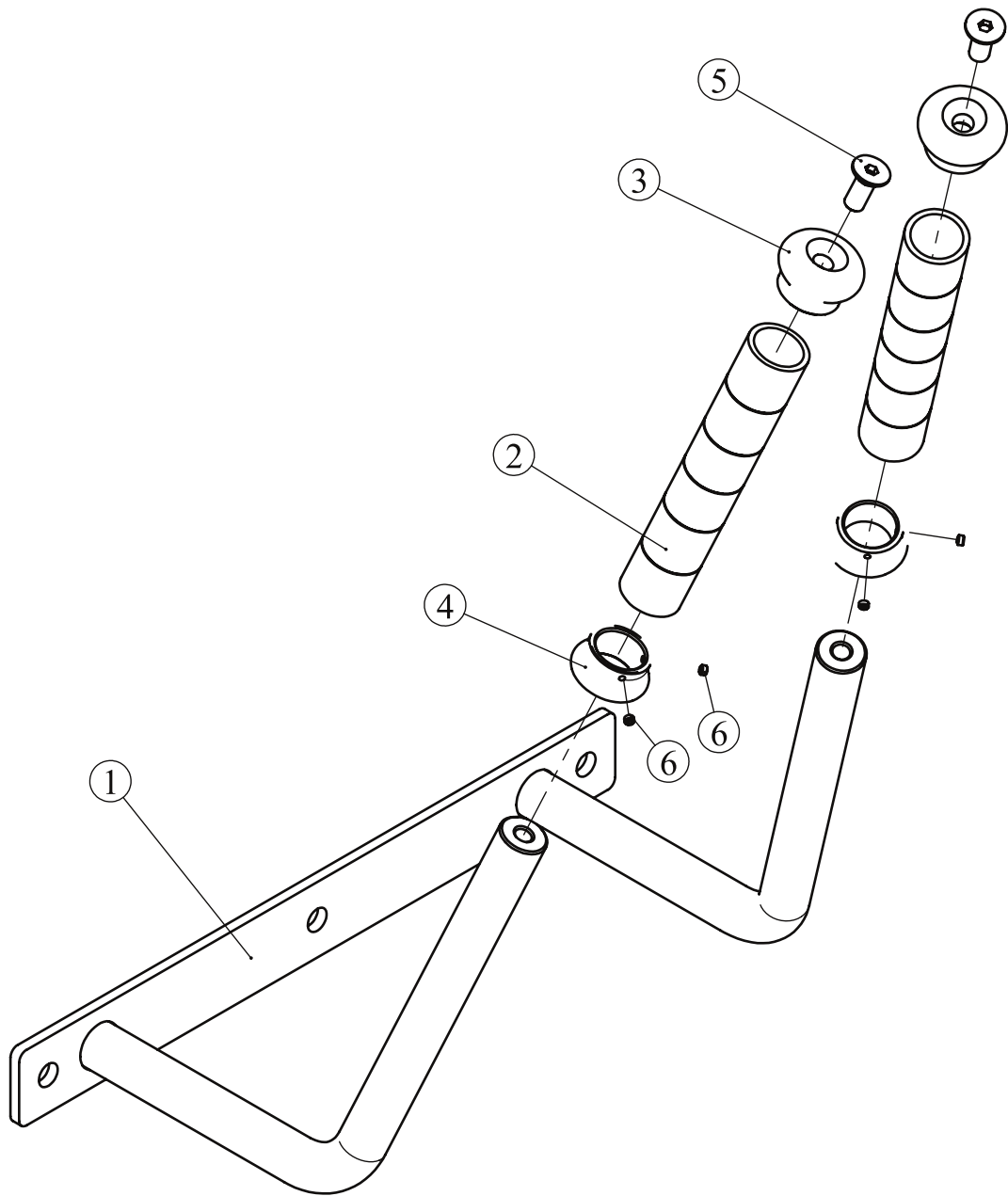

ITEM NO.	Description	QTY
1	Handle Frame	1
2	Aluminum Grip	2
3	Aluminum Cap Φ 25	2
4	Aluminum Ring Φ 25	2
5	Flat Head Cap Screw M10*25	2
6	Socket Set Screw 10-32*3.2	4

Exploded View and Parts List

WT Arm ASSY

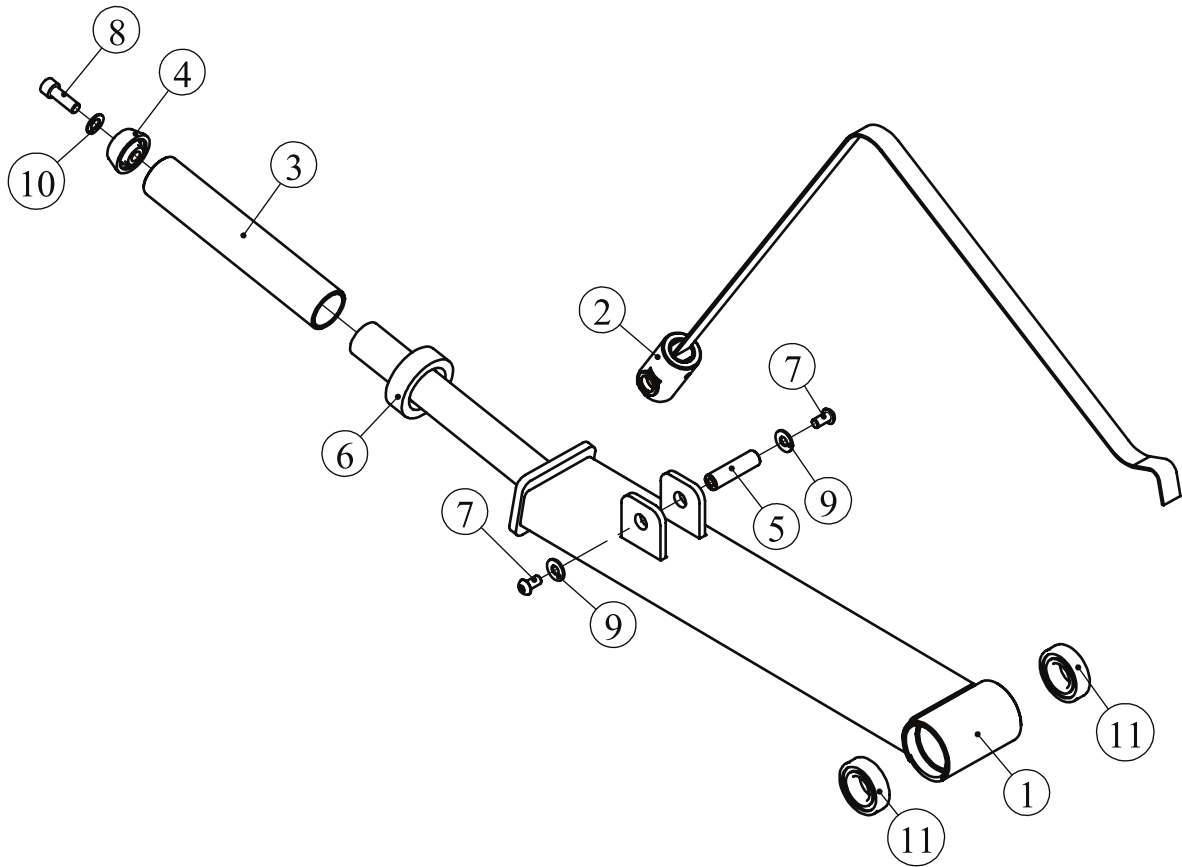

ITEM NO.	Description	QTY
1	WT Arm	1
2	Belt ASSY	1
3	Weight Horn Sleeve	1
4	Weight Horn Plastic Cap	1
5	Short Shaft	1
6	Weight Horn Rubber Donut $\Phi 76$	1
7	Button Head Cap Screw M10*20	2
8	Socket Head Cap Screw M12*35	1
9	Flat Washer $\Phi 11*\Phi 25*2$	2
10	Flat Washer $\Phi 13*\Phi 24*1.5$	1
11	Deep Groove Ball Bearing $\Phi 30$	2

Exploded View and Parts List

Leg ASSY

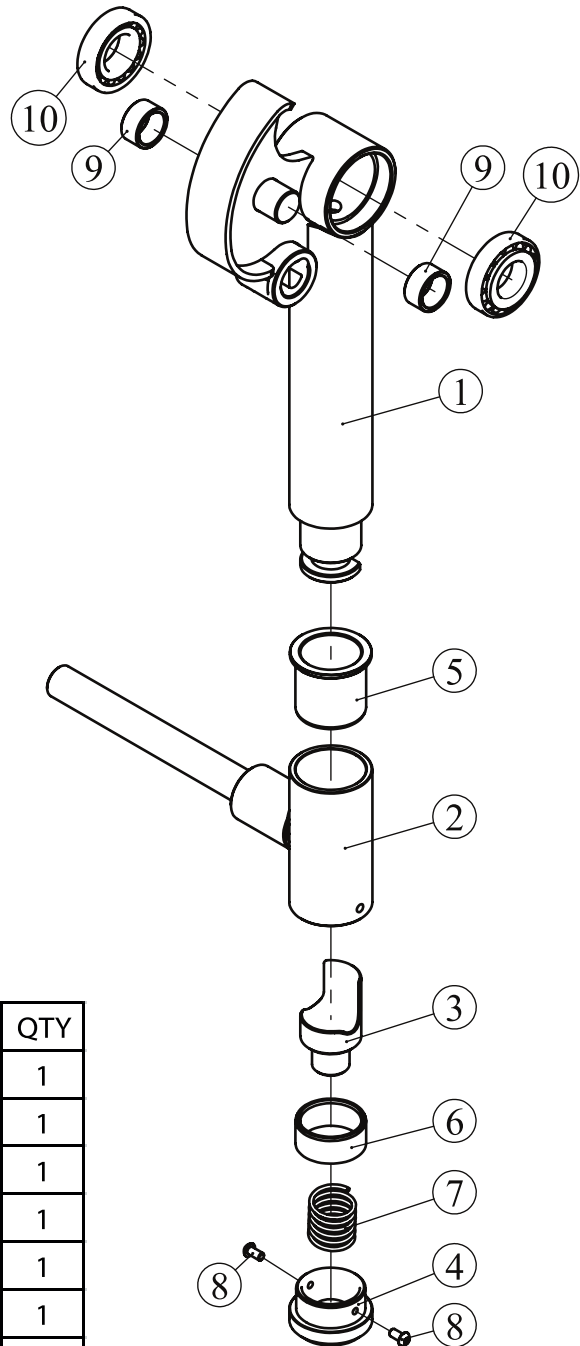

ITEM NO.	Description	QTY
1	Leg	1
2	Roller Frame	1
3	Stop Block	1
4	End Cap, AL $\Phi 60$	1
5	Bushing $\Phi 59$	1
6	Bushing $\Phi 51$	1
7	Spring $\Phi 34$	1
8	Button Head Cap Screw M6*12	2
9	Stop Sleeve $\Phi 32$	2
10	Deep Groove Ball Bearing $\Phi 30$	2

Exploded View and Parts List

Belt ASSY

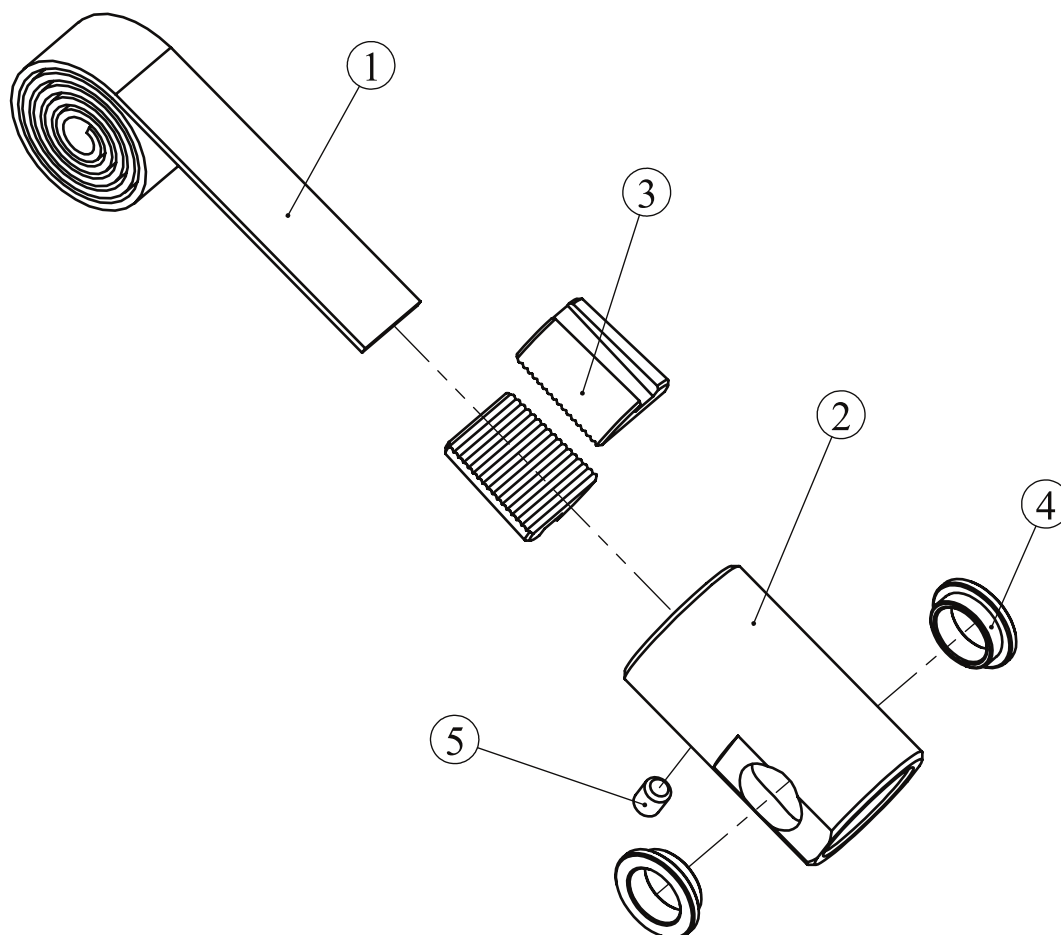

ITEM NO.	Description	QTY
1	Belt	1
2	Taped Cylinder, Belt	1
3	Half Shaft	2
4	Bushing $\Phi 28$	2
5	Socket Set Screw M8*10	1

Exploded View and Parts List

Overall

ITEM NO.	Description	QTY	ITEM NO.	Description	QTY
1	Left Bottom Frame ASSY	1	20	Short Shaft	1
2	Right Bottom Frame ASSY	1	21	Roller End Plate	2
3	Stanging Frame ASSY	1	22	End Cap, AL, DIA Φ 43	1
4	Up Support Frame ASSY	1	23	Socket Head Cap Screw M8*25	2
5	Rotating Frame ASSY	1	24	Socket Head Cap Screw M12*35	8
6	Bracket Frame ASSY	1	25	Socket Head Cap Screw M12*85	2
7	Support Frame ASSY	1	26	Socket Head Cap Screw M12*125	3
8	Cross Frame ASSY	1	27	Socket Head Cap Screw M12*135	10
9	Handle Frame ASSY	1	28	Button Head Cap Screw M10*75	10
10	WT Arm Assembly	1	29	Flat Head Cap Screw M10*25	1
11	Leg ASSY	1	30	Flat Head Cap Screw M12*30	5
12	Knee Pad	2	31	Nylon Nut M12	15
13	Leg Pad	2	32	Flat Washer Φ 11* Φ 20*2	11
14	Roller	1	33	Flat Washer Φ 13* Φ 24*1.5	38
15	Arm Pad	1	34	Button Head Cap Screw M10*30	1
16	Shaft Φ 30*81	1	35	Hex Key S=10	1
17	Shaft Φ 30*134	1	36	Hex Key S=8	1
19	Domed Aluminium Cap Φ 54	5	37	Hex Key S=6	1

Exploded View and Parts List

Overall

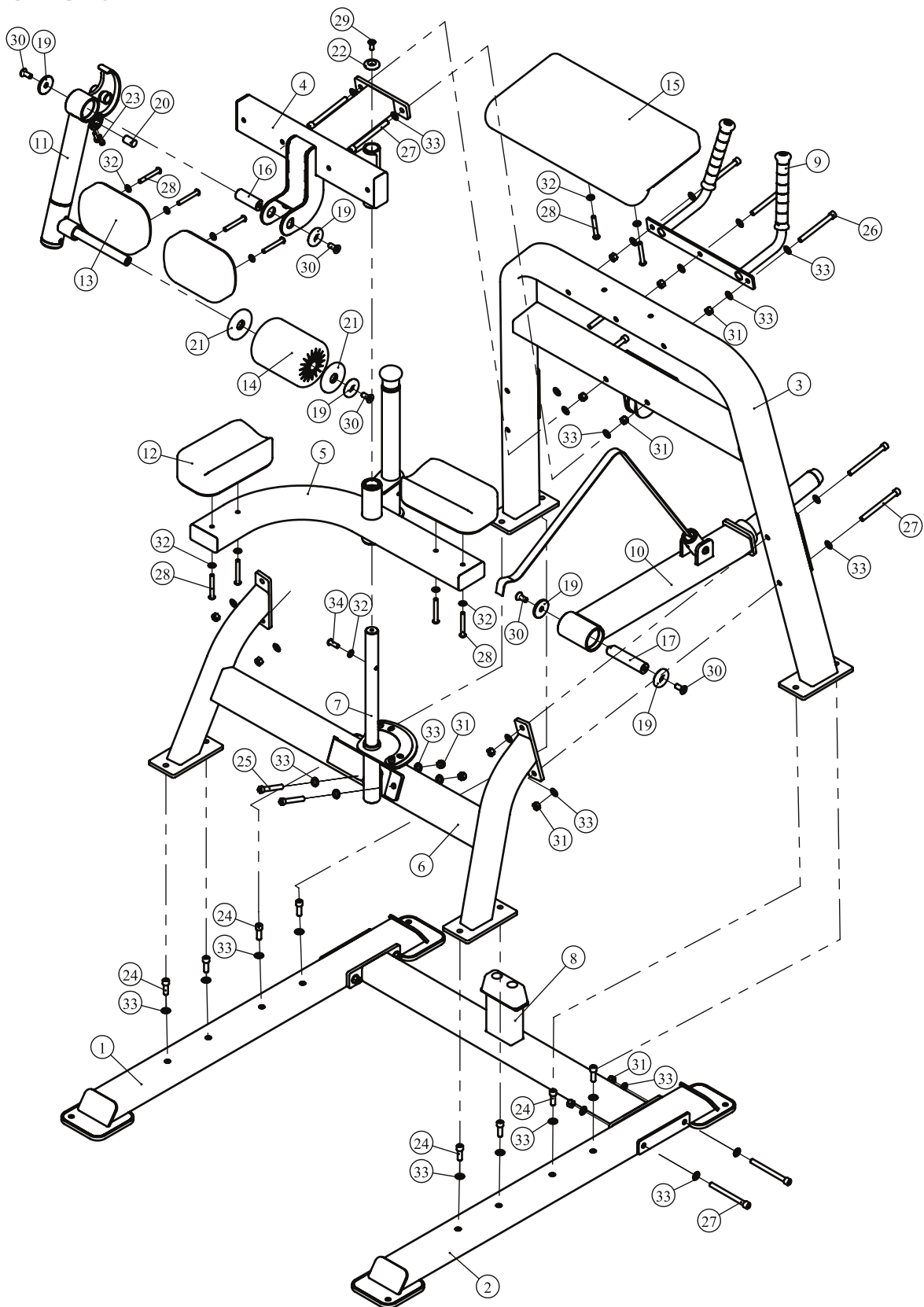

Measurement Guide

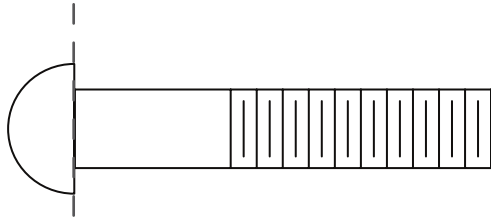

BHCS = Button Head Cap Screw

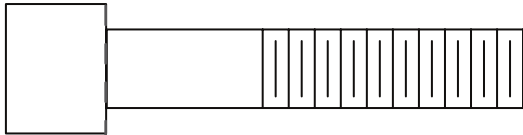

SHCS = Socket Head Cap Screw

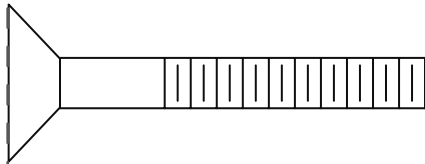

FHCS = Flat Head Cap Screw

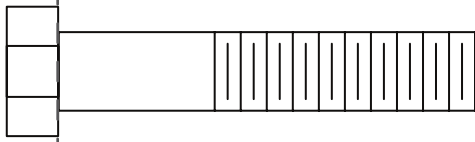

HHB = Hex Head Bolt

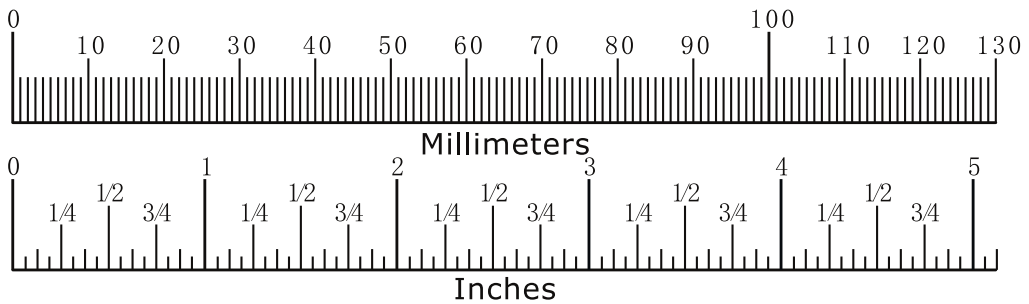

Diameter of bolt (mm/inch)	M6(1/4")	M8(5/16")	M10(3/8")	M12(1/2")	M16(5/8")
Tightening torque (N.m)	9~12	22~30	45~59	78~104	193~257
Operational methods for adult men	The strength of the wrist	The strength of the wrist and forearm	The strength of the entire arm	The strength of the arm and upper body	with all strength

Assembly Instructions

Assembly of the equipment takes professional installers about 2 hours. If this is the first time you have assembled this type of equipment, plan to spend more time. It is strongly recommended to assemble the equipment by professional installers. You may find it quicker, safer, easier to assemble this equipment with the help of a friend, as some of components may be large, heavy or awkward to handle alone. It is important that you assemble your product in a clean, clear, uncluttered area. This will enable you to move around the product while you are fitting components and reduce the possibility of injury during assembly.

NOTE

As with any assembled part, proper alignment and adjustment is critical. While tightening the fasteners, be sure to leave room for adjustments. Do not fully tighten the fasteners until instructed to do so. Be careful to assemble the components in the sequence presented in this guide.

Assembly

STEP 1

Attach Left Bottom Frame ASSY (#1), Right Bottom Frame ASSY (#2) to Cross Frame ASSY (#8), using:

- four M12*135 SHCS (#27)
- four M12 Nylon lock Nuts (#31)
- eight $\Phi 13*\Phi 24*1.5$ Flat Washers (#33)

Note: DO NOT tighten the hardware.

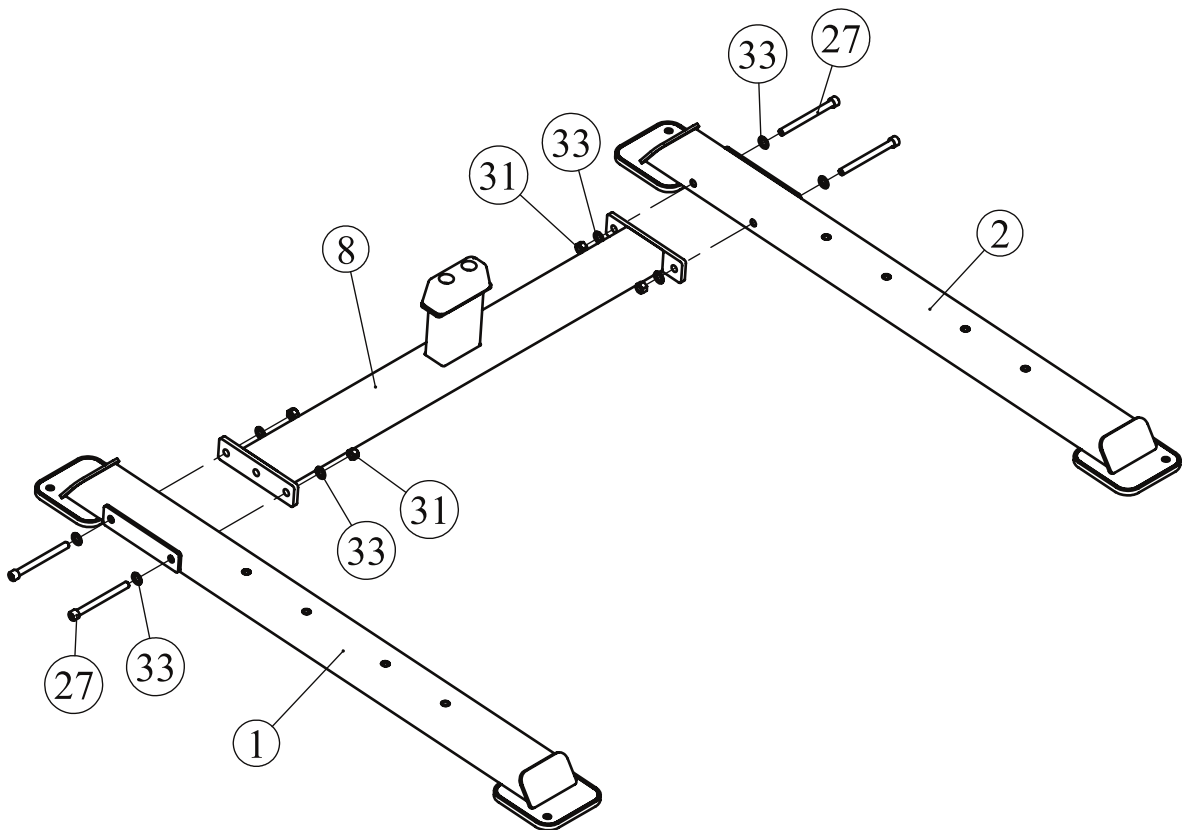

Assembly

STEP 2

Attach Stanging Frame ASSY (#3), Bracket Frame (#6) to Left Bottom Frame ASSY (#1), Right Bottom Frame ASSY (#2), using:

- eight M12*35 SHCS (#24)
- four M12*135 SHCS (#27)
- four M12 Nylon lock Nuts (#31)
- sixteen $\Phi 13 \times \Phi 24 \times 1.5$ Flat Washers (#33)

Note: DO NOT tighten the hardware.

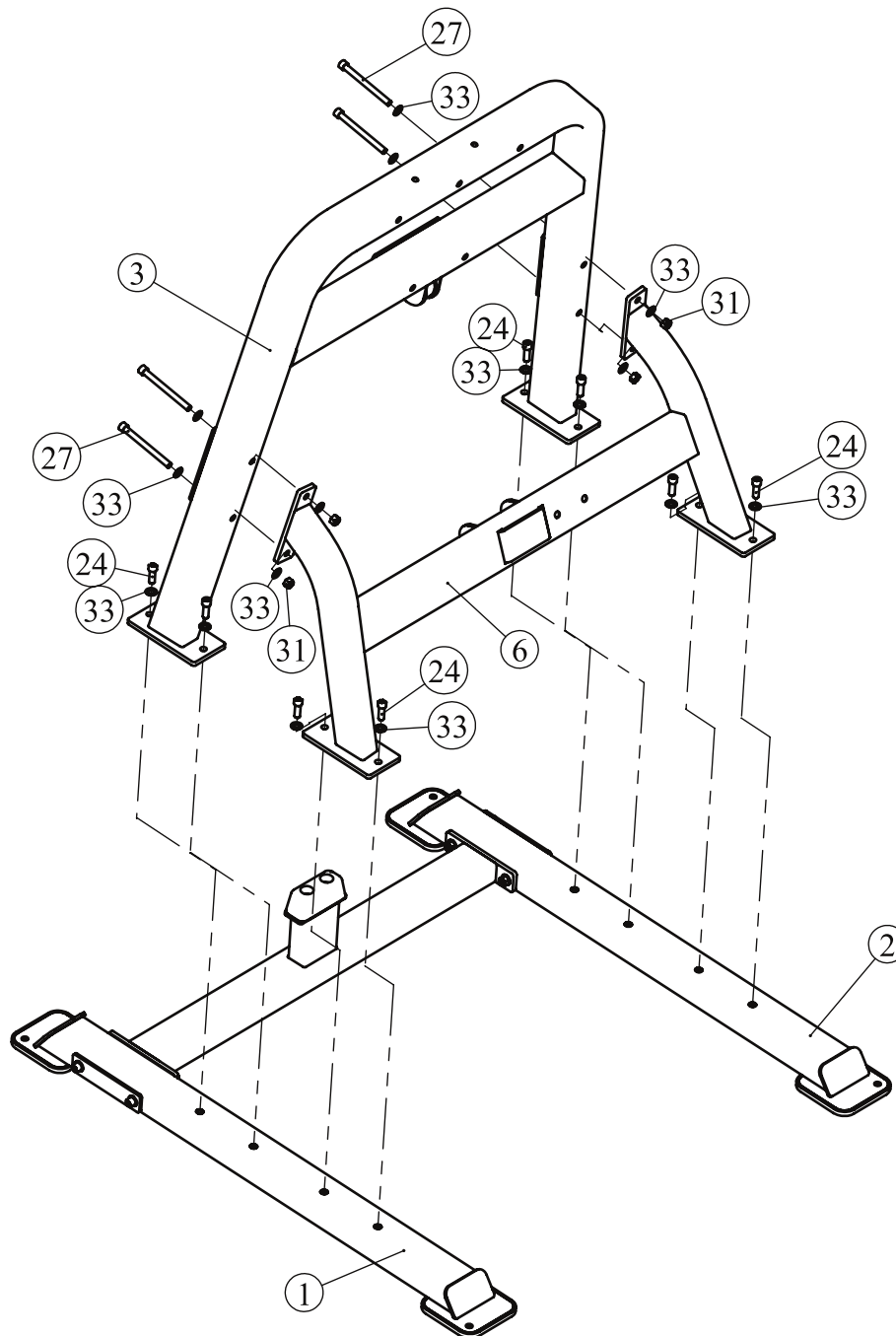

Assembly

STEP 3

1. Attach Support Frame ASSY (#7) to Bracket Frame (#6), using:

- two M12*85 SHCS (#25)
- two M12 Nylon lock Nuts (#31)
- four $\Phi 13*\Phi 24*1.5$ Flat Washers (#33)

2. Attach Rotating Frame ASSY (#5), Up Support Frame ASSY (#4) to Support Frame ASSY (#7), using:

- one $\Phi 43$ End Cap, AL, DIA (#22)
- one M10*25 FHCS (#29)
- one M10*30 BHCS (#34)
- one $\Phi 11*\Phi 20*2$ Flat Washers (#32)

3. Attach Up Support Frame ASSY (#4) to Stangding Frame ASSY (#3), using:

- two M12*135 SHCS (#27)
- two M12 Nylon Lock Nuts (#31)
- four $\Phi 13*\Phi 24*1.5$ Flat Washers (#33)

Note: Adjusted and Tighten all the hardware.

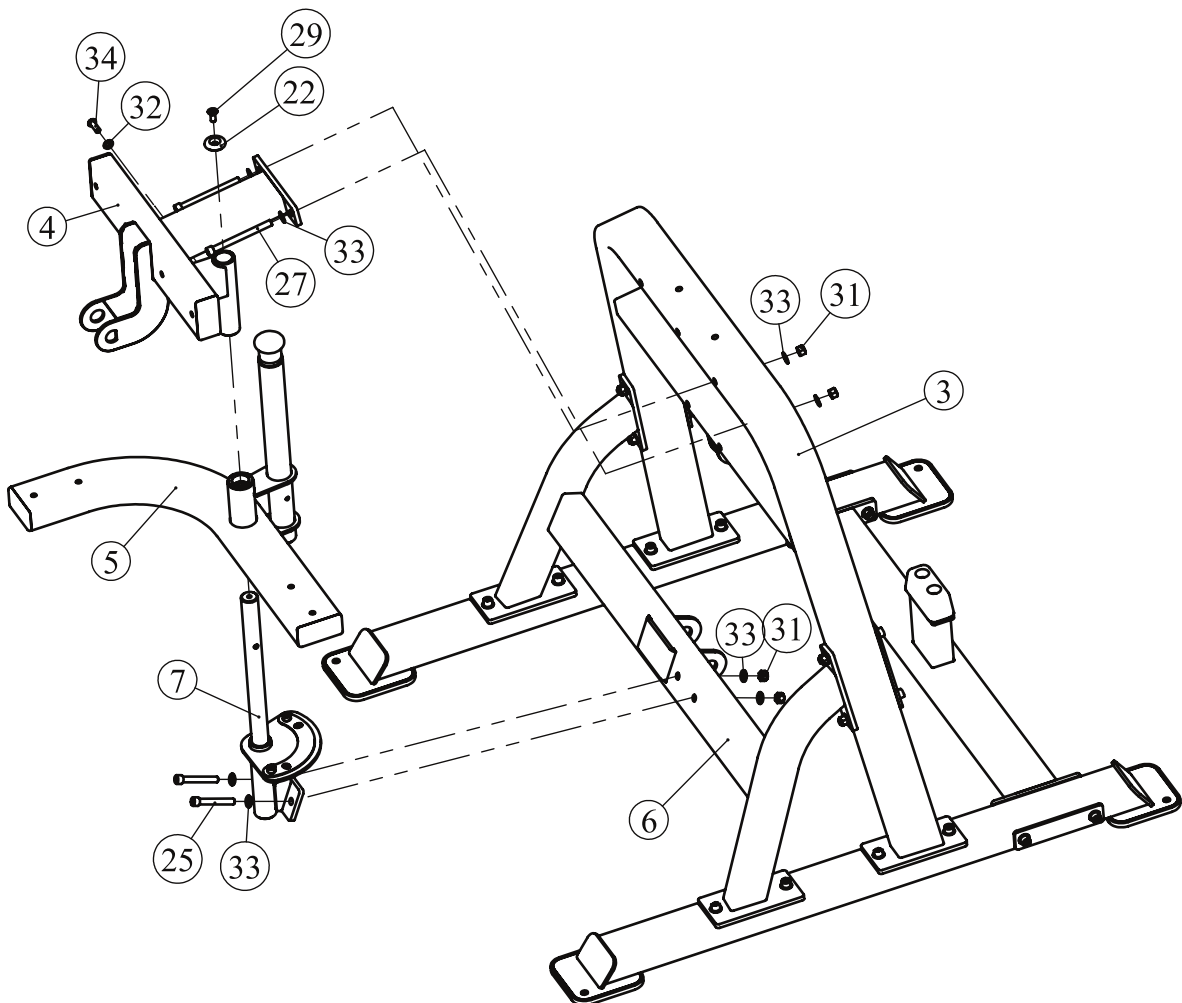

Assembly

STEP 4

Attach Handle Frame ASSY (#9) to Stanging Frame ASSY (#3), using:

- three M12*125 SHCS (#26)
- three M12 Nylon lock Nuts (#31)
- six $\Phi 13*\Phi 24*1.5$ Flat Washers (#33)

Note: Tighten the hardware.

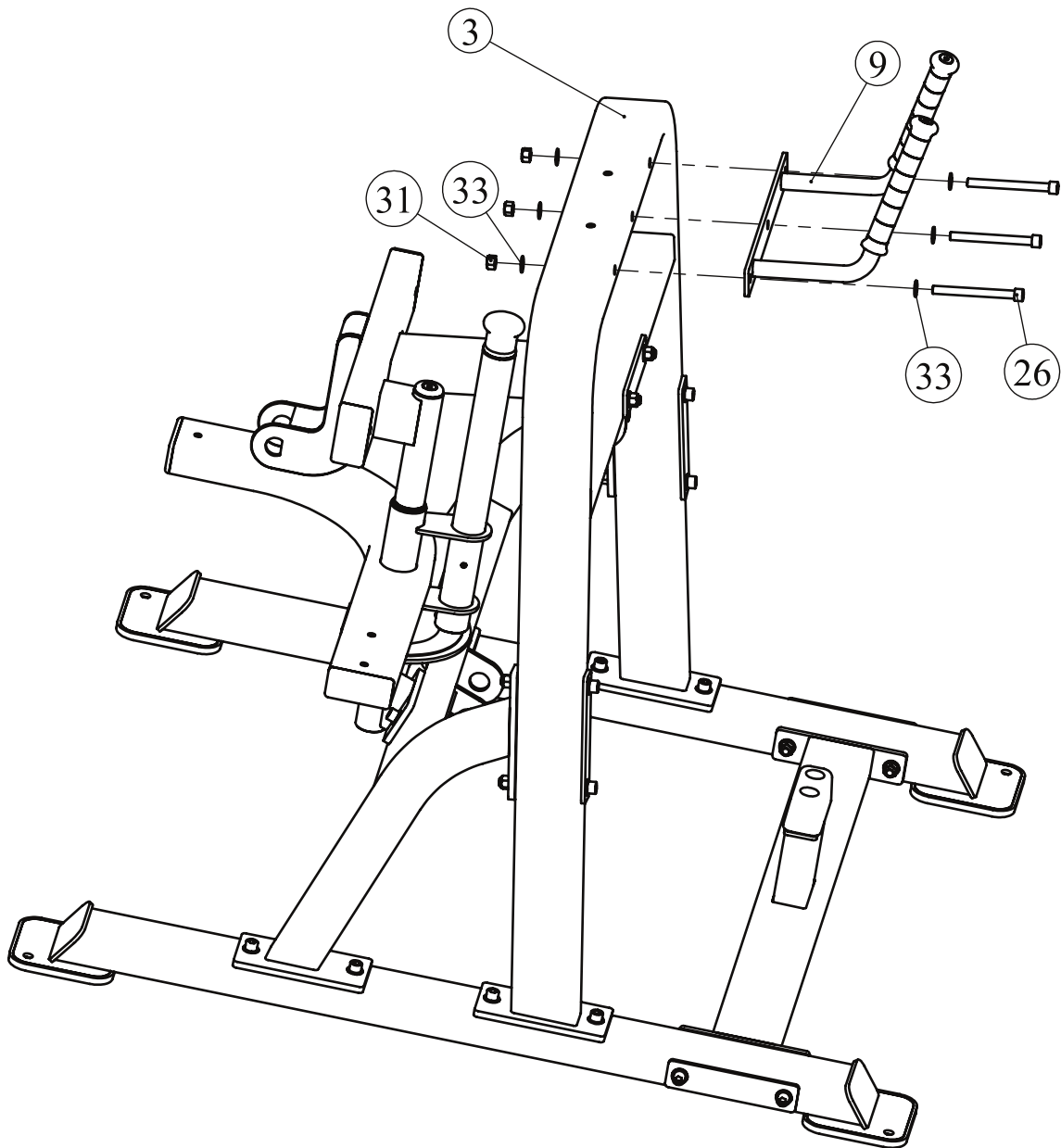

Assembly

STEP 5

Attach Leg ASSY (#11) to Up Support Frame ASSY (#4), using:

- one $\Phi 30 \times 81$ Shaft (#16)
- two $\Phi 54$ Domed Aluminium Cap (#19)
- two M12*30 FHCS (#30)

Note: Tighten the hardware.

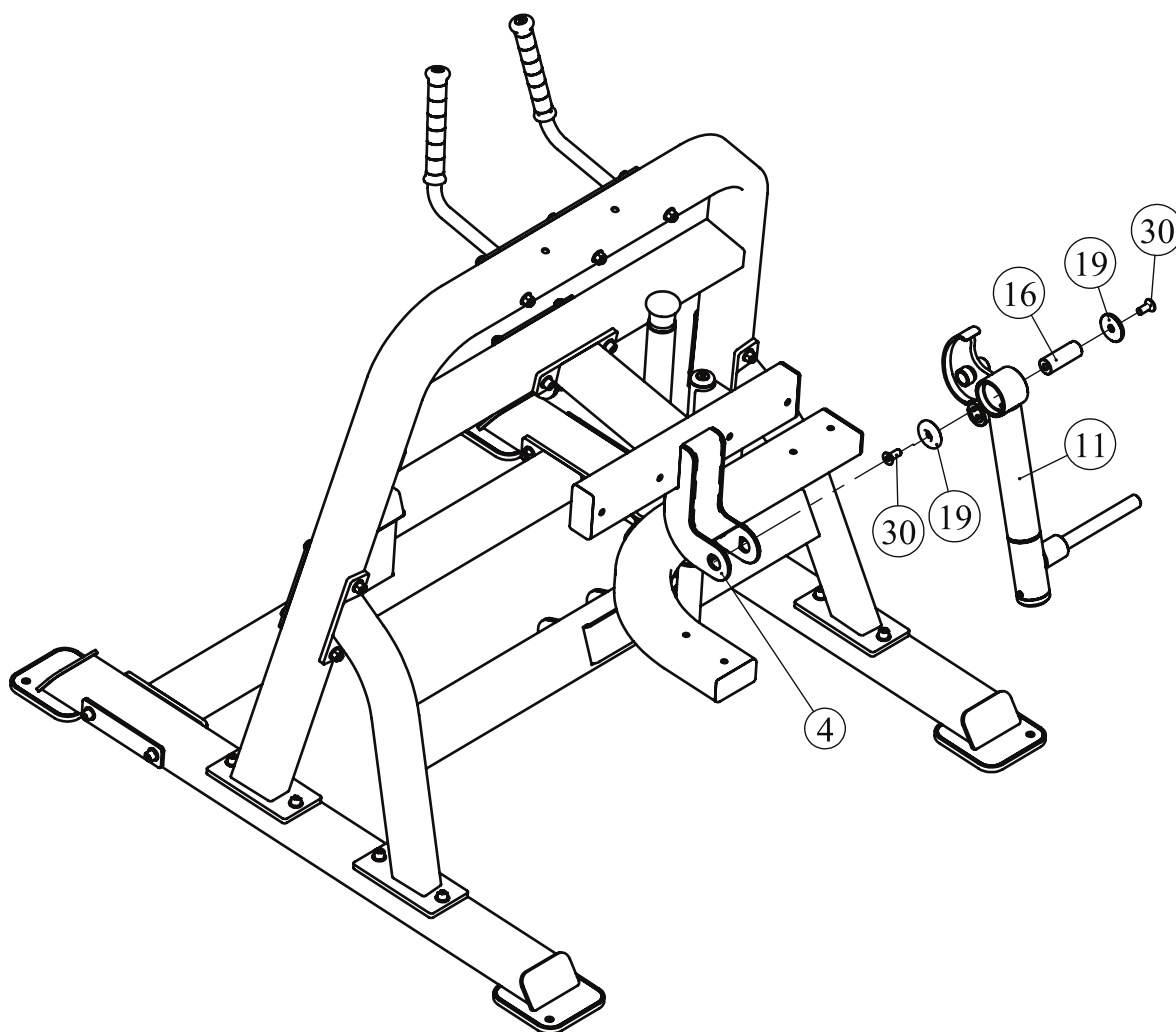

Assembly

STEP 6

1. Attach WT Arm Assembly (#10) to Bracket Frame (#6), using:

- one $\Phi 30 \times 134$ Shaft (#17)
- two $\Phi 54$ Domed Aluminium Cap (#19)
- two M12*30 FHCS (#30)

2. Attach Belt to Leg ASSY (#11), using:

- one short shaft (#20)
- two M8*25 SHCS (#23)

Note: Tighten the hardware.

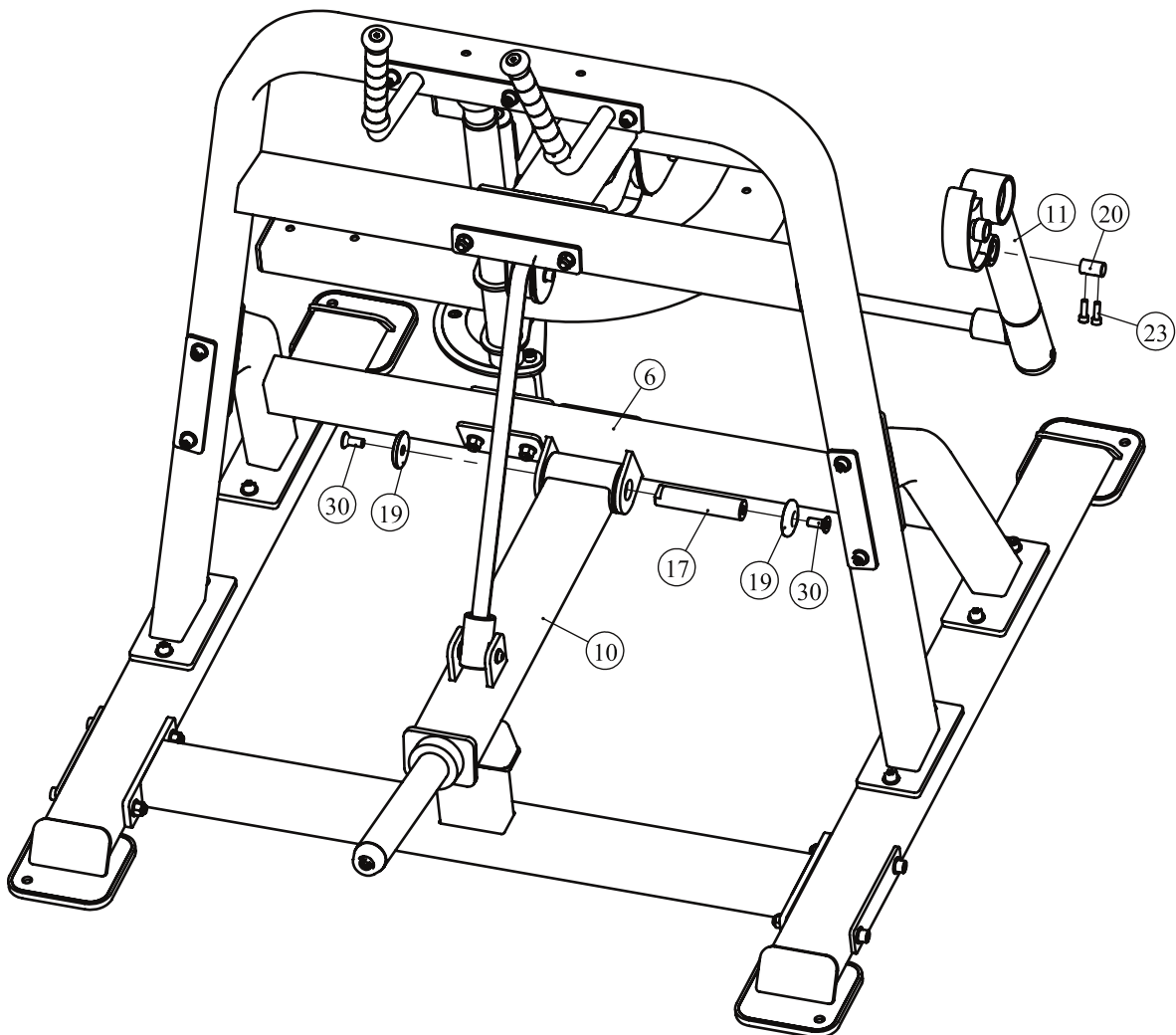

Assembly

STEP 7

1. Attach Two Knee Pad (#12) to Rotating Frame ASSY (#5), using:

- four M10*75 BHCS (#28)
- four $\Phi 11*\Phi 20*2$ Flat Washers (#32)

2. Attach Two Leg Pad to Up Support Frame ASSY (#4), using:

- four M10*75 BHCS (#28)
- four $\Phi 11*\Phi 20*2$ Flat Washers (#32)

3. Attach Arm Pad (#15) to Stanging Frame ASSY (#3), using:

- two M10*75 BHCS (#28)
- two $\Phi 11*\Phi 20*2$ Flat Washers (#32)

4. Attach Roller (#14) to Leg ASSY (#11), using:

- two Roller End Plate (#21)
- one $\Phi 54$ Domed Aluminium Cap (#19)
- one M12*30 FHCS (#30)

Note: Tighten the hardware.

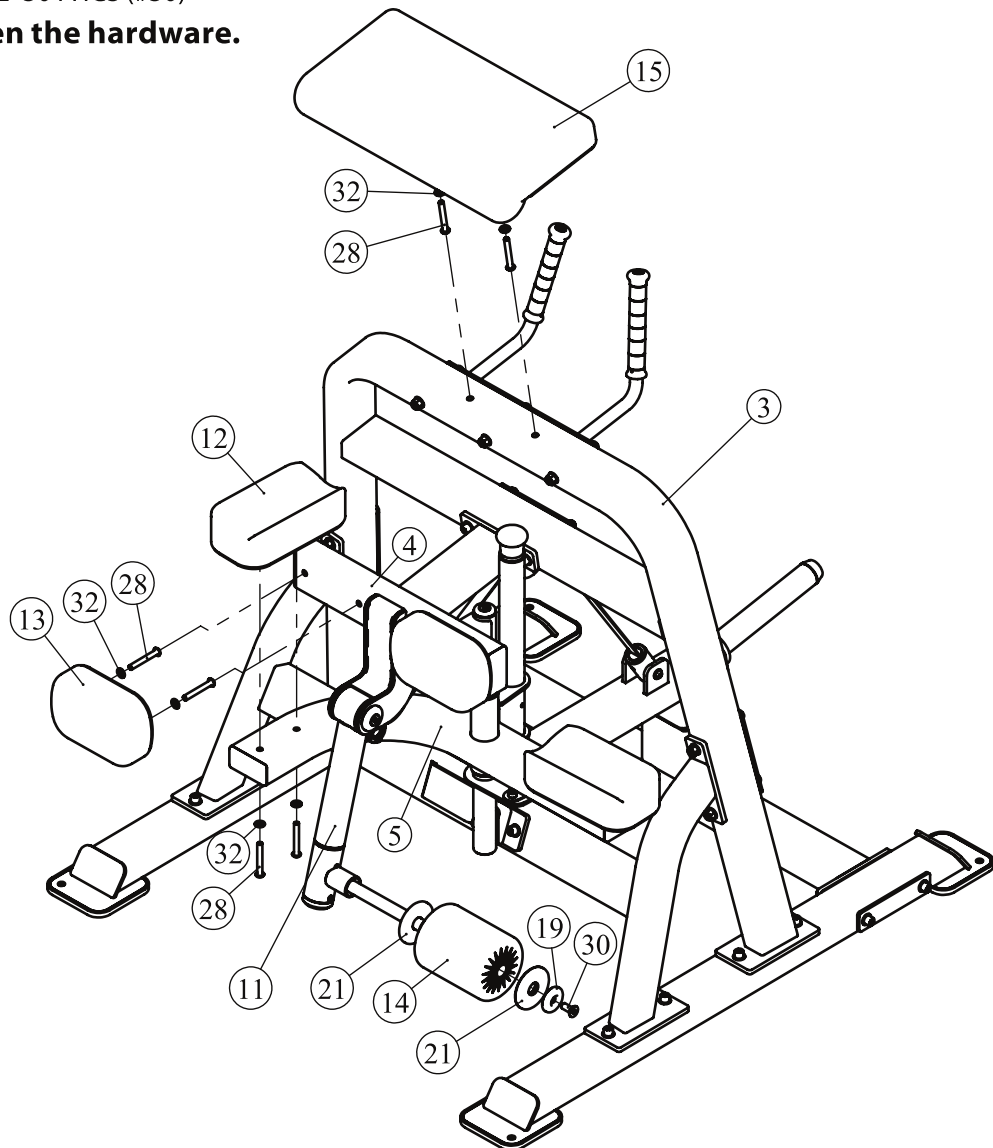

Adjust Instructions

Weight Plate Installation Requirements

1. Please use Olympic Weight Plate which hole is greater than $\Phi 50\text{mm}$ and external diameter is less than $\Phi 500\text{mm}$.
2. The total weight of one side can not be greater than 120kg.
3. This equipment does not contains Weight Plate.

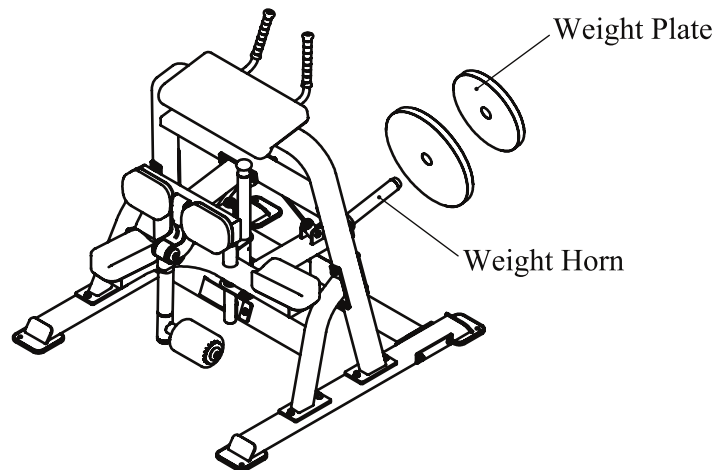

Knee Pad adjustment

1. Pull the Pull Pin and adjust Knee Pad to left or right position as shown.
2. Make sure the Pull Pin gets into the hole completely.

Roller Pad adjustment

Adjust Roller Pad to right or left position as shown.

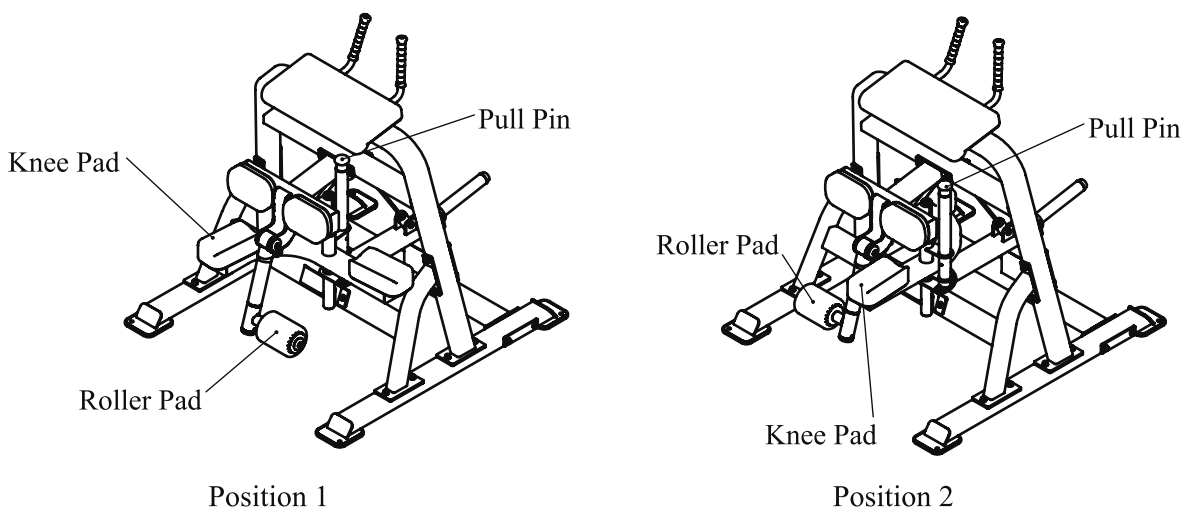

Exercise Instructions

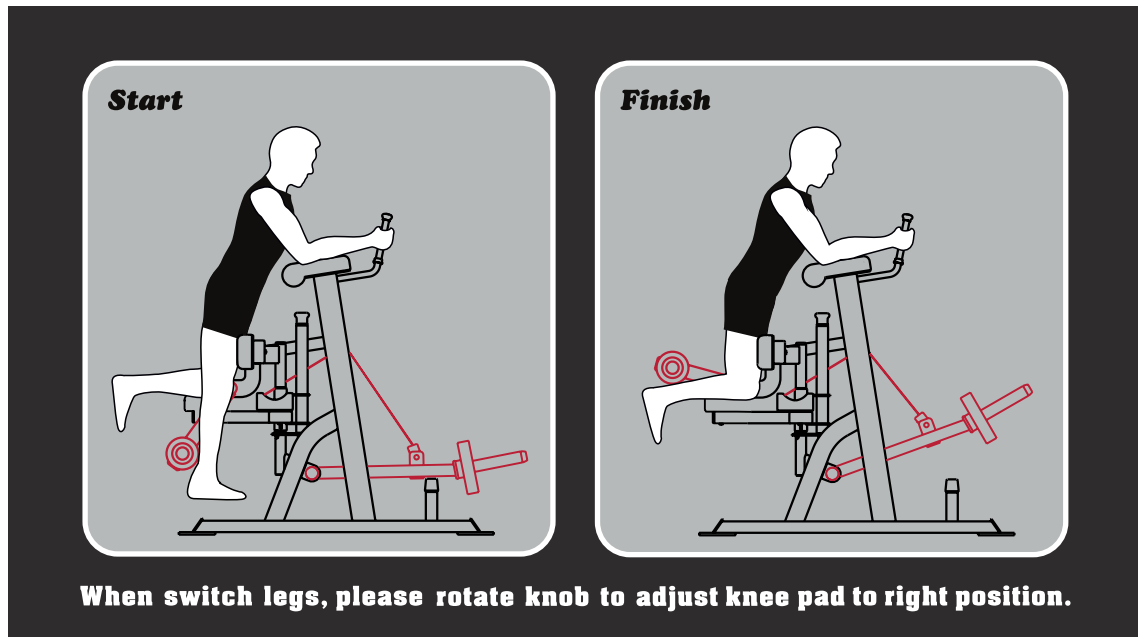

Exercise Instructions

1. Select an appropriate weight.
2. Hold the handles and kneel on Knee Pad by one leg.
3. Kick the Roller Pad back slowly by another leg.
4. Pause slightly then slowly return to the starting position.

Maintenance Schedule

ROUTINE	COMMERCIAL MAINTENANCE	HOME MAINTENANCE	LATEST DATE ENTRY						
Inspect; Links, Pull Pins, Snap Locks, Swivels, Weight Stack Pins	DAILY	WEEKLY							
Clean; Upholstery	DAILY	WEEKLY							
Inspect; Cables or Belts and their tension	DAILY	WEEKLY							
Inspect; Accessory Bars, and Handles	WEEKLY	3 MONTHS							
Inspect; All Decals	WEEKLY	3 MONTHS							
Inspect; All Nuts and Bolts, Tighten if needed	WEEKLY	3 MONTHS							
Inspect; Anti-Skid Surface	WEEKLY	3 MONTHS							
Clean & Lubricate; Guide Rods with a Teflon (PTFE) based lubricant (Superlube)	MONTHLY	3 MONTHS							
Lubricate; Seat Sleeves, Turcite Bushings, Linear Bearing	MONTHLY	3 MONTHS							
Clean and Wax; All Glossy Finishes	6 MONTHS	YEARLY							
Repack with Grease; Linear Bearings	6 MONTHS	YEARLY							
Replace; Cables, Belts and Connecting Parts	YEARLY	3 YEARS							

Your equipment comes with a commercial maintenance decal. For personal, in home use, please follow the home maintenance schedule listed above.

General Maintenance Information

Links, Pull-Pins, Snap Hooks, Swivels, Weight Stack Pins:

- * Check all pieces for signs of visible wear or damage.
- * Check springs in snap hooks and pull-pins for proper tension and alignment.
- * If the spring sticks or has lost its rigidity, replace it immediately.

Upholstery:

- * To ensure prolonged upholstery life and proper hygiene, all upholstered pads should be wiped down with a damp cloth after every workout.
- * Periodically take the time to use a mild soap or an approved vinyl upholstery cleaner to deter the onset of cracking or drying. Avoid using any abrasive cleaners or cleaners not intended for use on vinyl.
- * Replace ripped or worn upholstery immediately.
- * Keep sharp or pointed objects clear of all upholstery.

Decals:

- * Inspect and familiarize yourself with any safety warnings or other user information posted on each decal.

Nuts and Bolts:

- * Inspect all nuts and bolts for any loosening and tighten if needed.
- * Go through a re-tightening sequence periodically to ensure that all hardware is tensioned proper.

Anti-Skid Surfaces:

- * These surfaces are designed to supply secure footing and need to be replaced if they appear worn or become slippery.

Belts and Cables:

- * We use only high quality belt, and mil-spec cables.
- * Visually inspect the belts and cables for fraying, cracking, peeling or discoloration.
- * While the machine is not in use, carefully run your fingers along the belt or cable to feel for thinning or bulging areas.
- * Replace belts and cables immediately at the first signs of damage or wear. Do not use equipment until belts or cables have been replaced.

Belt and Cable Tension:

- * Referring to the Owners Manual, when belts or cables are used check all bolt attachments to be sure they are properly attached.
- * Check slack in cables and re-adjust cable tension if needed.

Seat Sleeves, Guide Rods:

- * Wipe down adjusting tubes with a dust free rag before applying lubricant.
- * Lubricate seat sleeves and Guide Rods with a Silicon or Teflon based lubricant spray.

Linear Bearings:

- * Referring to the Owners Manual carefully disassemble the bearing from its housing and place a finger full of light grease (lithium, super lube, etc.) into the inside of the bearing. Using your finger, press the grease into the ball-bearings and their tracks. Repeat until the ball-bearing tracks are full of grease. Insert the shaft back into the bearing and wipe off excess grease.

PLEASE KEEP THIS FOR YOUR RECORDS

Weight Training Tips

Use this manual to guide you through the basic exercises you can perform on your equipment. To gain maximum results and avoid possible injury, consult a fitness professional to develop your complete exercise program.

Always consult your physician before starting any exercise program.

To be successful in your exercise program, it is important to develop an understanding of the basic principles of strength training. Now that you have your equipment, it is only natural that you want to get started immediately. First, determine a set of realistic goals and objectives for yourself. By deciding on an exercise plan that is right for you prior to starting, you will contribute significantly to your success.

Warm up properly before engaging in weight resistance training. Stretching, yoga, jogging, calisthenics or other cardiovascular exercise can help prepare your body for the heavier workload of lifting weights.

Learn how to perform the exercise correctly before using heavy weight. Correct form is important to avoid injury and to ensure that you work the proper muscle groups.

Know your limitations. If you are new to weight training or are embarking on an exercise regimen after a long layoff, start slowly and build foundational strength over a longer period of time.

Pay attention to your breathing. Exhale when you exert is a general rule of thumb. Never hold your breath.

