

TAURUS

Assembly and operating instructions

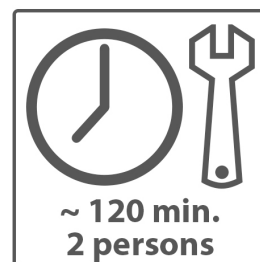
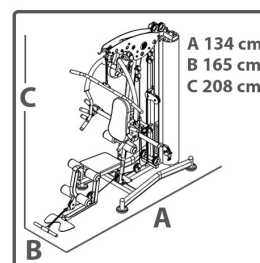
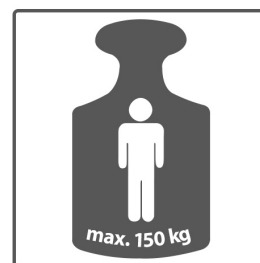
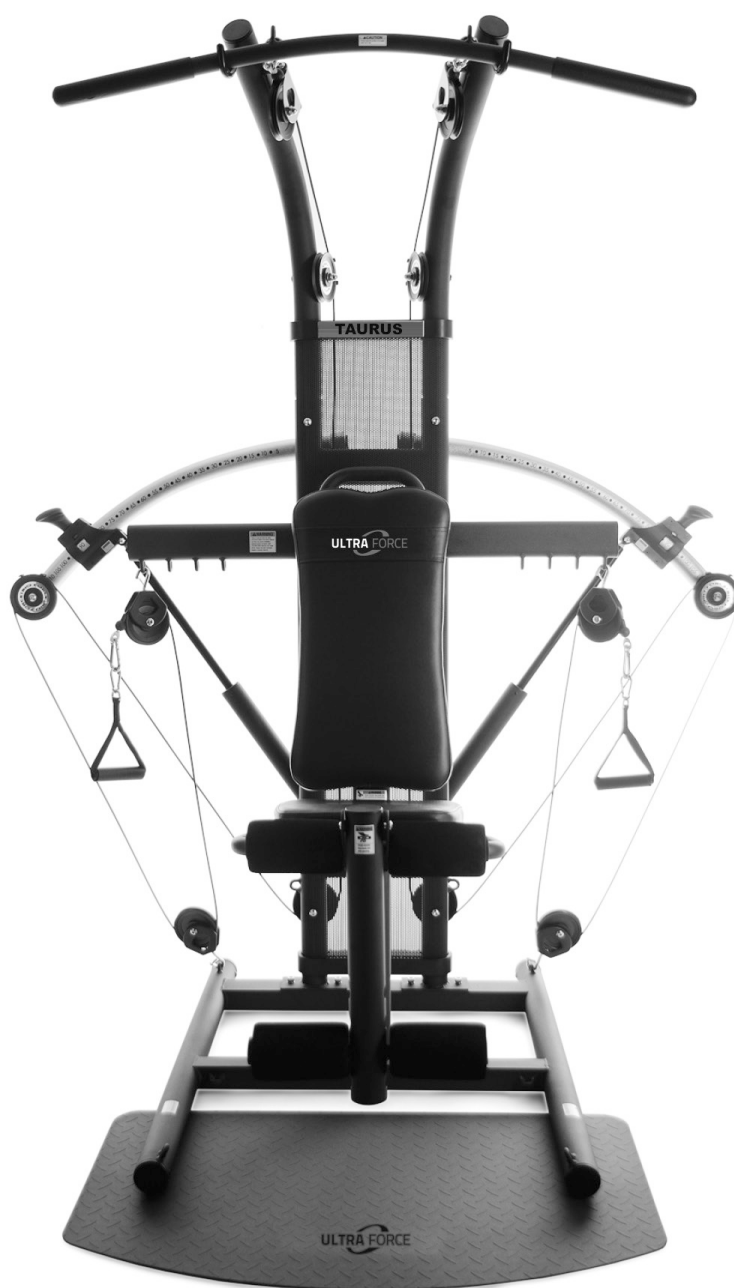

TF-UF

Multi-gym UltraForce

Dear Customer,

Thank you for deciding for a high-quality training equipment of the brand Taurus, the brand that makes athlete's hearts beat faster. Taurus offers a wide range of home fitness equipment like elliptical cross trainers, ergometers, treadmills and rowing machines. Taurus equipment is the optimal equipment for all those who want to train at home independent of goals and fitness level. For further information please visit www.sport-tiedje.com or www.taurus-fitness.de.



SAFETY NOTICE

Please read all of the instructions carefully before assembly and first use. These instructions are intended to ensure speedy assembly and explain safe usage. Make sure that all people exercising with the equipment (in particular children and persons with limited physical, sensory, mental or motor capabilities) are informed about these instructions and its content in advance. In case of doubt, a responsible person must supervise the use of the equipment.

This equipment has been manufactured according to the latest safety knowledge. As far as possible, potential safety hazards which could cause injury have been eliminated. Make sure to follow the instructions carefully and that all parts are securely in place. If required, read through the instructions again to correct any mistakes.

Please pay close attention to the safety and maintenance instructions given here. The contract partner cannot be held liable for damage to health, accidents or damage to the equipment when it is not used in accordance with these instructions.

The equipment is only suitable for use at home. The equipment is not suitable for semi-professional (e. g., hospitals, clubs, hotels, schools, etc.) and commercial or professional use (e. g., health clubs).

Retain these instructions in a safe place for future reference, maintenance or when ordering replacement parts.

CONTENTS

1	GENERAL INFORMATION	6
1.1	Technical data	6
1.2	Personal safety	7
1.3	Set-up place	8
2	ASSEMBLY INSTRUCTIONS, MAINTENANCE AND CARE	9
2.1	General instructions	9
2.2	Faults and Troubleshooting	10
2.3	Maintenance and service calendar	10
3	ASSEMBLY	11
3.1	Parts overview	11
3.2	Warning notes/warning sticker	12
3.3	Assembly	16
4	WORKOUT INSTRUCTIONS	33
4.1	General training instructions	33
4.2	Exercise and safety notes	34
4.3	Exercise manual	35
4.4	Equipment settings	35
4.5	Stretching exercises	37
4.6	Workout journal	39
5	WARRANTY INFORMATION	40
6	DISPOSAL	42
7	ORDERING ACCESSORIES	42
8	ORDERING SPARE PARTS	43
8.1	Service hotline	43
8.2	Serial number and model name	43
8.3	Parts list	44
8.4	Exploded drawing	48
9	EXERCISE MANUAL	50

1.1 Technical data

Weight and dimensions:

Article weight (gross, including packaging): 88.6 kg

Article weight (net, without packaging): 87 kg

Packaging dimensions of the box (L x W x H):

No. 1 approx. 151 cm x 49 cm x 22 cm, weight: 42 kg (gross, including packaging)

No. 2 approx. 116 cm x 85 cm x 16 cm, weight: 46.61 kg (gross, including packaging)

Set-up dimensions (L x W x H): approximately 134 cm x 165 cm x 208 cm

Maximum user weight: 150 kg/330 lbs

1.2 Personal safety

- + Before you start using the equipment, you should consult your physician that this type of exercise is suitable for you from a health perspective. Particularly affected are persons who: have a hereditary disposition to high blood pressure or heart disease, are over the age of 45, smoke, have high cholesterol values, are overweight and/or have not exercised regularly in the past year.
- + Please note that working out excessively can seriously damage your health.
- + The equipment may only be used for its intended purpose; this means for power training by adults.
- + Any other usage is prohibited and potentially dangerous. The contract partner cannot be held liable for damage resulting from improper use.
- + The equipment may not be used by several persons at the same time.
- + Children should not be allowed unsupervised access to the equipment.
- + Before starting your training, make yourself familiar with all of the equipment's functions and setting options. Have an expert explain the correct usage of the product to you.
- + Make sure that nobody is in the range of motion of the equipment while exercising.
- + Keep your hands, feet and other body parts, hair, clothing, jewelry and other objects well clear of moving parts.
- + During use, wear suitable sports clothing rather than loose or baggy clothing. When selecting sports shoes, think about the suitability of the sole – preferably this should be made of rubber or other non-slip materials. Shoes with heels, leather soles, studs or spikes are not suitable. Never work out in bare feet.
- + It is also important to take note of the information given in the workout instructions for creating a workout plan.
- + At the first signs of weakness, nausea, dizziness, pain, difficulty in breathing or other abnormal symptoms, stop your workout immediately and, if necessary, consult your physician.
- + Handicap people must have a medical certificate before they may use the equipment and should be closely monitored when they use any training equipment.
- + Before each training session, check all cables for any possible damage. Immediately replace defective cables and do not use the equipment until it has been repaired. Also pay attention to any material fatigue.
- + Never let go of the handlebars or grips as long as there is resistance in order to avoid crushing and similar injuries.
- + Make sure that the cables are always in the wheel guide. If the cables are stuck while you are training, stop training immediately and check the cable run.
- + If you adjust the seat, make sure that it fully locks in its new position, because otherwise it may slide and lead to injuries.

1.3 Set-up place

- + The equipment should only be used indoors, in a sufficiently heated and dry area (ambient temperature between 10°C and 35°C). The equipment should not be used outdoors or in rooms with high humidity (over 70%) like swimming pools. The equipment should only be stored in surroundings with an ambient temperature between 5°C and 45°C.
- + The training room should be well ventilated during training and not be exposed to any draughts.
- + Choose a location in which to place the equipment such that there is enough free space/ clearance to the front, the rear and to the sides of the equipment (at least 1.50 m). Furthermore, the equipment should not be set up in main entrances or on escape routes.
- + No objects of any type should be inserted into the openings of the equipment.
- + The equipment should be placed on a level and solid surface, any unevenness in the floor should be leveled out.
- + A floor protective mat / equipment underlay can help to protect high-quality floor coverings (parquet, laminate, cork, carpets) from dents and sweat and can help to level out slight unevenness.
- + Store your equipment where children cannot come into contact with it and there is not much traffic.

2.1 General instructions

- + Please check if all parts and tools belonging to the equipment are included in the delivery and if there is any transport damage. If there are any complaints, please contact your contract partner directly.
- + Some of the nuts and bolts to be used in assembly are already pre-mounted in order to make set-up as easy as possible.
- + The equipment must be assembled by adults. In case of doubt, ask for assistance from another person with technical skills.
- + Keep children away from the equipment during assembly, because small parts are included in the delivery and may be swallowed.
- + Make sure that you have enough space (at least 1.50 m) in every direction during assembly.
- + Do not leave any tools and packaging materials like plastic sheeting laying around to avoid danger of suffocation for children.
- + Assemble the equipment on an underlay mat or on the cardboard packaging in order to avoid damage to the equipment and to the floor (scratches).
- + Before starting assembly, all individual parts should be placed on the floor next to each other.
- + Read the assembly instructions carefully and assemble the equipment according to the illustrations. Proceed carefully and cautiously.
- + First loosen all parts and check for their correct fitting. Then tighten the screws using a tool.
- + Modifications to the design or improper repairs may pose a hazard to the user and should not be carried out. The product warranty may be void as a result.
- + Only authorized service technicians are permitted to carry out all servicing and/or repairs – it excludes maintenance and care.
- + Damaged or worn components may impair your safety and the lifespan of the equipment. You should therefore immediately replace damaged or worn components. Please contact your contract partner in such a case. The equipment should no longer be used until it has been repaired. When needed, only use original Taurus spare parts.
- + Check the tightness of all screw connections once a month.
- + In order to be able to guarantee the constructively defined safety level of this equipment, we recommend having the equipment regularly maintained (at least once a year) by specialists (service technicians of your contract partner).
- + The equipment may be cleaned of dust, dirt and sweat using a damp cloth. The use of solvents should be strictly avoided. Also, make sure that no liquids (e. g. sweat) get into the openings of the equipment.

2.2 Faults and Troubleshooting

The equipment runs through regular quality controls during production. Nevertheless, errors or malfunctions on the equipment may occur. Individual parts are often the cause of faults and replacement is usually sufficient. Please use the following overview to see the five most common errors and how to repair them. If the equipment still does not work properly, please contact your contract partner.

Error	Cause	Repair
Scraping noises	Cable or wheels are not running smoothly or are damaged	Visual inspection of the cable run or the wheel guide
No resistance	Defective cylinder	Check the cylinder for resistance
Squeaking & cracking noises	Loose or too tight screw connection	Check or lubricate screw connection

2.3 Maintenance and service calendar

The multi-gym needs to be cleaned after every training session with a moist towel (no solvent!) in order to avoid damage caused by sweat.

The following routine work must be done in the specified time intervals:

Part	Weekly	Monthly	2x annually	Annually
Pulling ropes and rollers	C / I			
Bolts		I		
Wheels and rope guide	I			
Legends: C = cleaning; I = inspect				

3.1 Parts overview

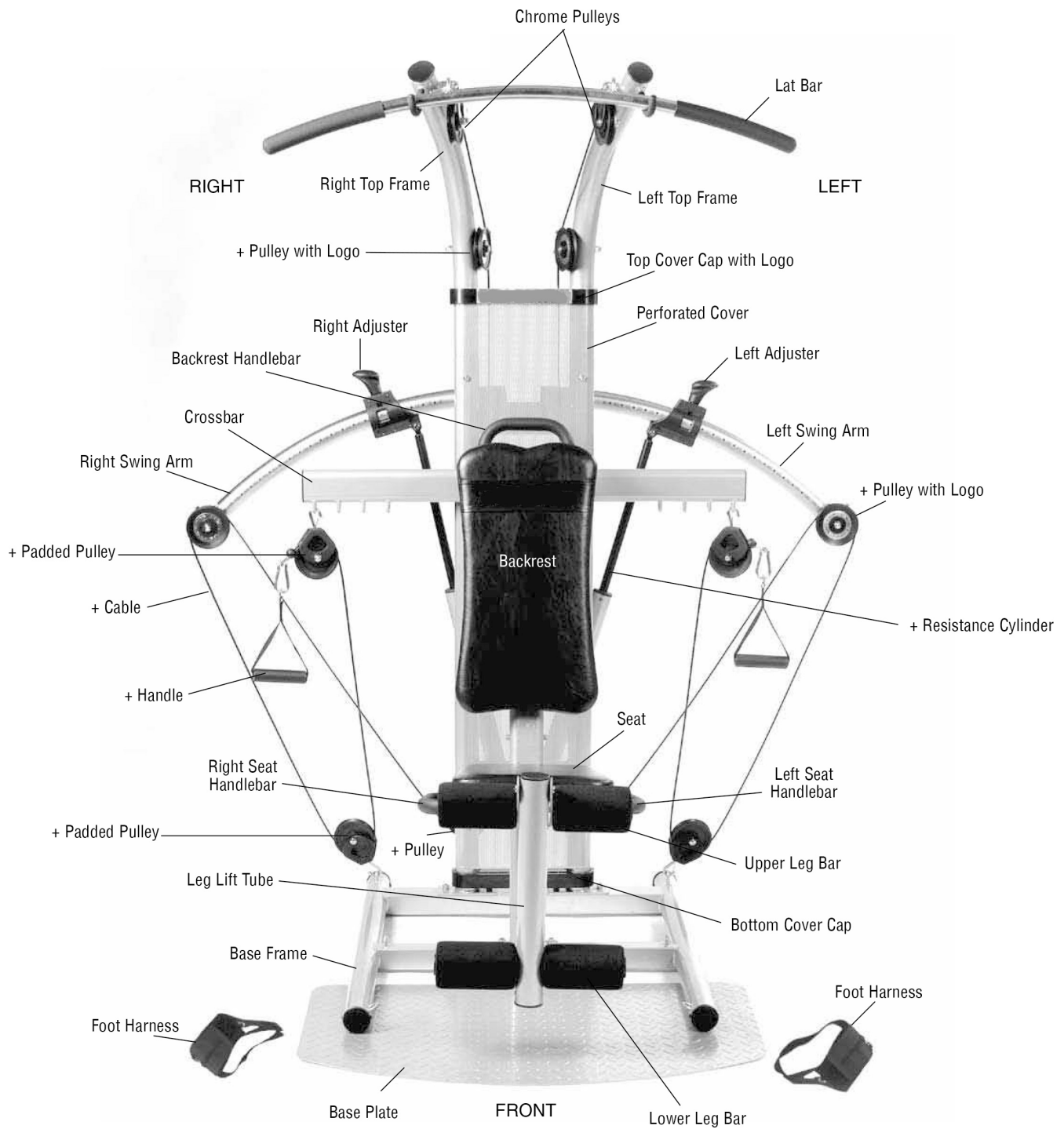

Note: All position specifications - front, back, left, right - from these instructions are coming from the seated position of the user on the equipment whereby the user looks forward.

3.2 Warning notes/warning sticker

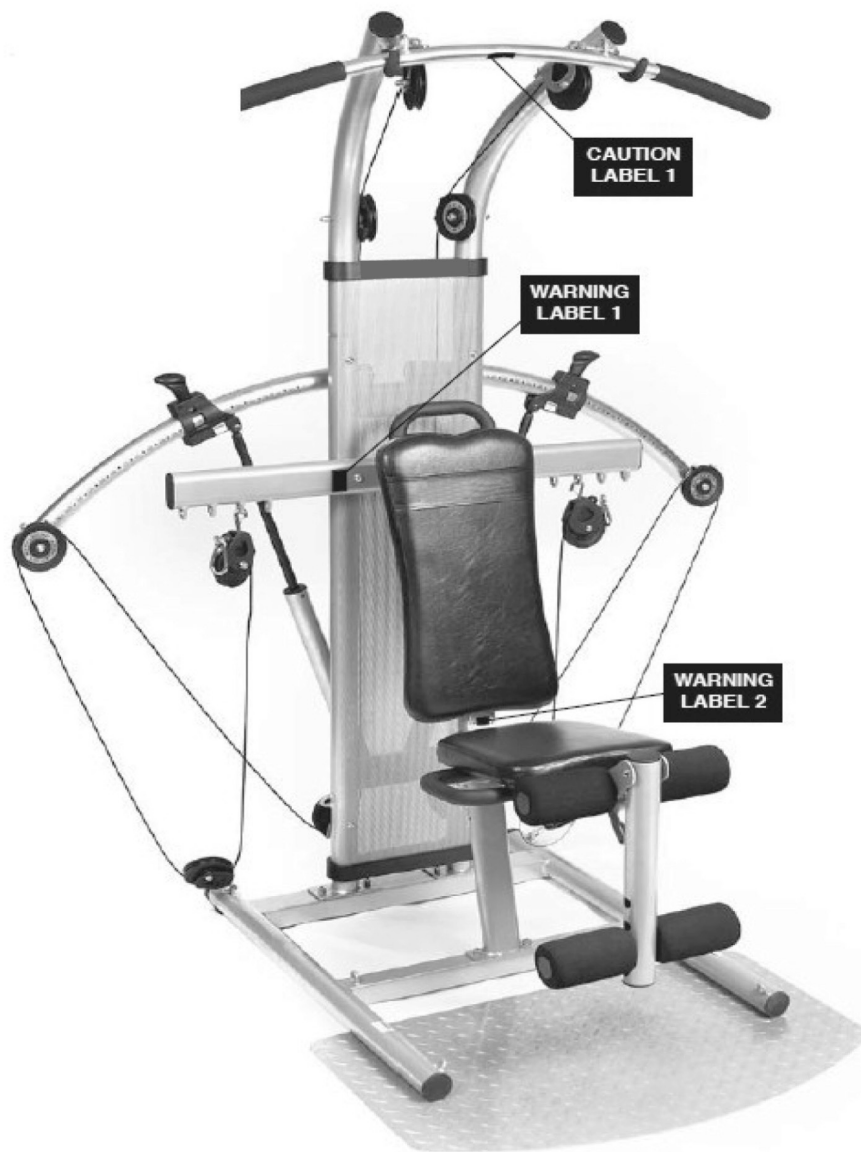

IMPORTANT: Please observe the attachment of the following warning and attention stickers on your equipment:

CAUTION LABEL 1

If you are not using the lat bar, always hang it in the holder.

WARNING LABEL 1

If you do not read and follow the safety instructions provided in the user instructions and video, this MAY RESULT IN SERIOUS INJURIES OR DEATH. KEEP AWAY FROM CHILDREN. Maximum user weight: 330 lbs/150 kg. Replace this sticker if it is damaged, illegible or was removed. Class HC.

WARNING LABEL 2

Crushing hazard: Keep hands away during assembly and disassembly.



WARNING LABEL 3

WARNING LABEL 5

WARNING LABEL 5

WARNING LABEL 3

Crushing hazard! Keep hands away while using!

WARNING LABEL 5 (6 positions)

Do not touch the pulleys and mobile parts.

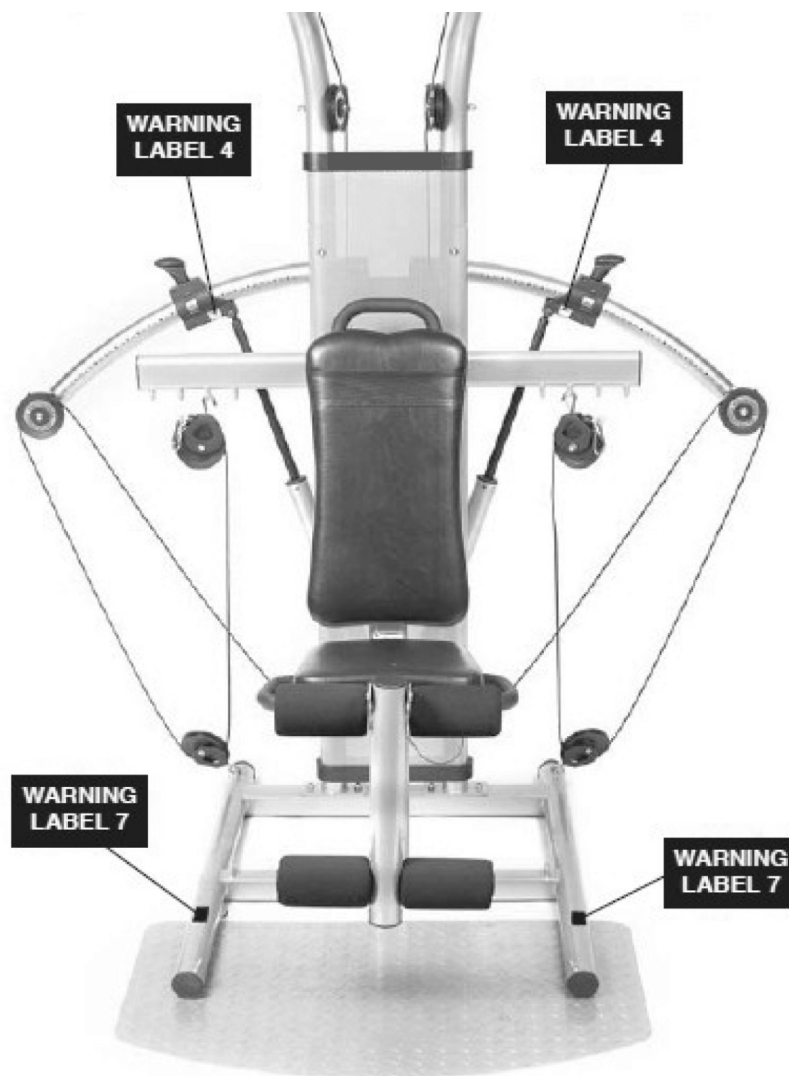

WARNING LABEL 4 (2 positions)

WARNING! Make sure that the pin is locked in the position before you begin the exercise.

WARNING LABEL 7 (2 positions)

WARNING! When you do exercises while standing, keep your feet on the ground plate.

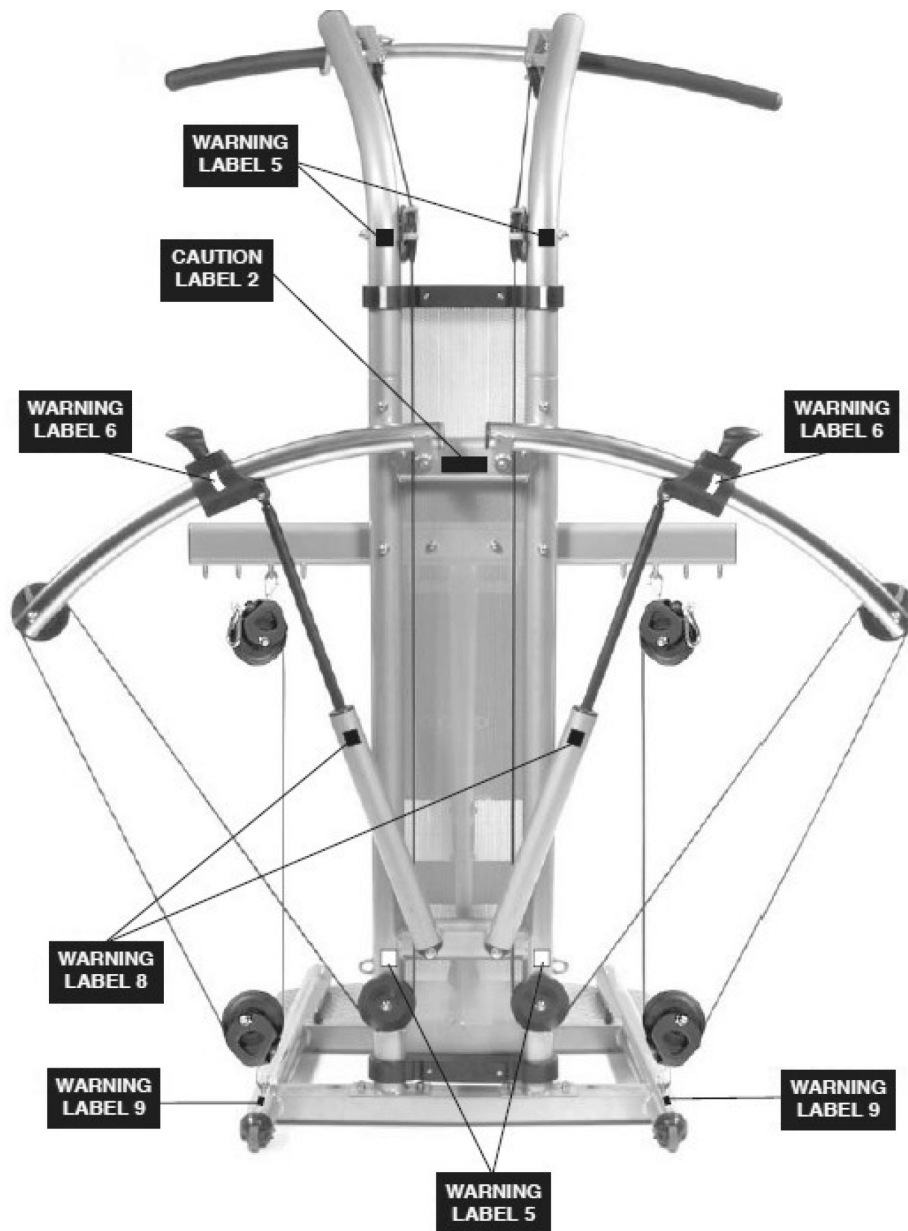

CAUTION LABEL 2

NOTE! In order to transport the equipment, we recommend doing this with two persons.

WARNING LABEL 5 (6 positions)

WARNING! Do not touch the pulleys and mobile parts.

WARNING LABEL 6 (2 positions)

WARNING! Crushing hazard - only use adjusting arm with free hands.

WARNING LABEL 8 (2 positions)

WARNING! Content under pressure; DO NOT OPEN. Keep away from heat and fire.

WARNING LABEL 9 (2 positions)

WARNING! Do not remove pulley form this position after the equipment has been assembled.

3.3 Assembly

In a few cases, our products contain parts that were pre-lubricated in the factory. During assembly and during training, we recommend protecting your floor with the mat.

Make sure that you have completely read the instructions and all parts and tools on p. 17 are available.

Approximately an 83 degree tilted angle is required to transport the product. Make sure that you have enough space before you begin with the assembly. We recommend assembling the equipment at the location that you will be using it.

ATTENTION! The transport should always be executed by two people.

All nuts and screws are brought in from the front to back - with the nut on the backside. Two persons are required for a few assembly steps.

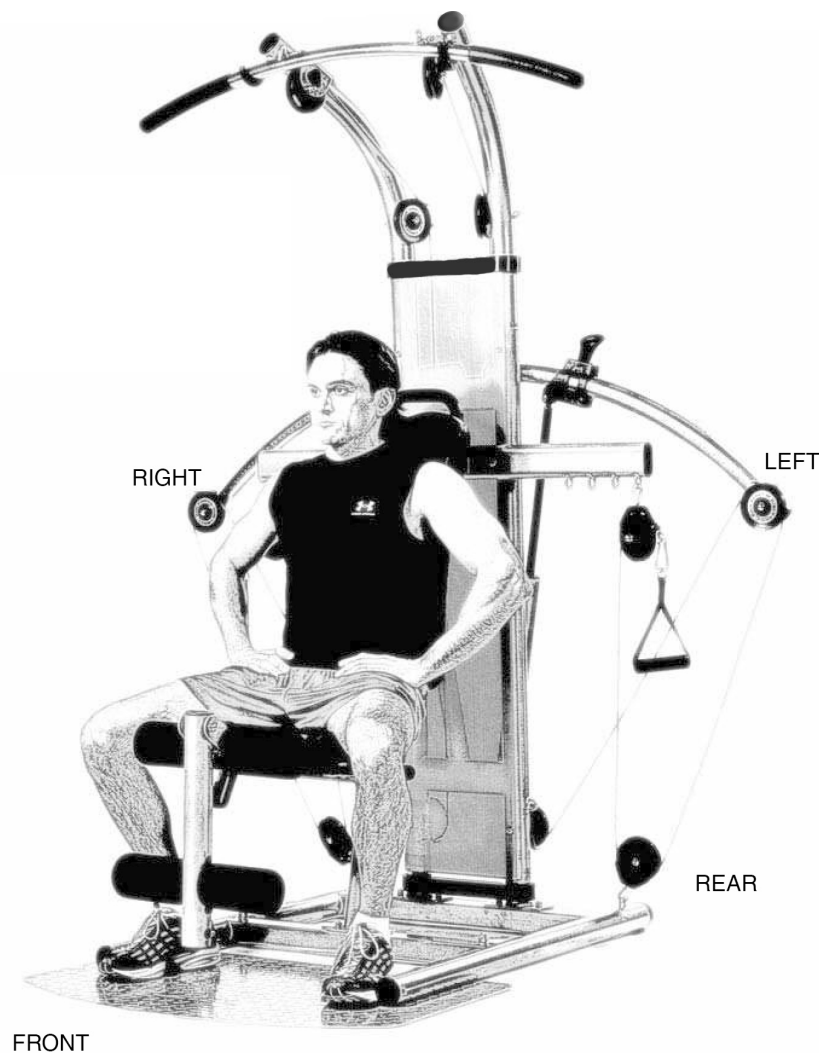

Packaging contents

Place the parts in front of you as in this image. Become familiar with the part numbers and names.

Make sure that the delivery is complete.

BOX 1

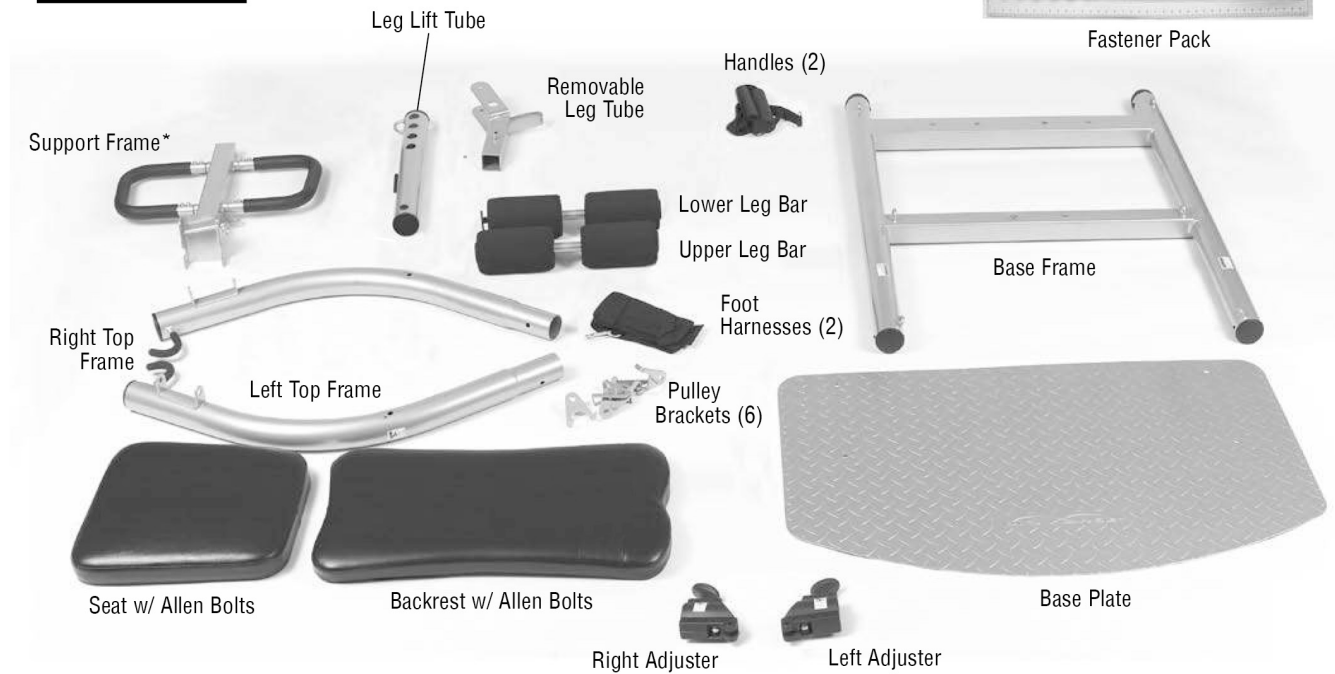

*Important: The Left and Right Seat Handlebars are attached to the Support Frame

BOX 2

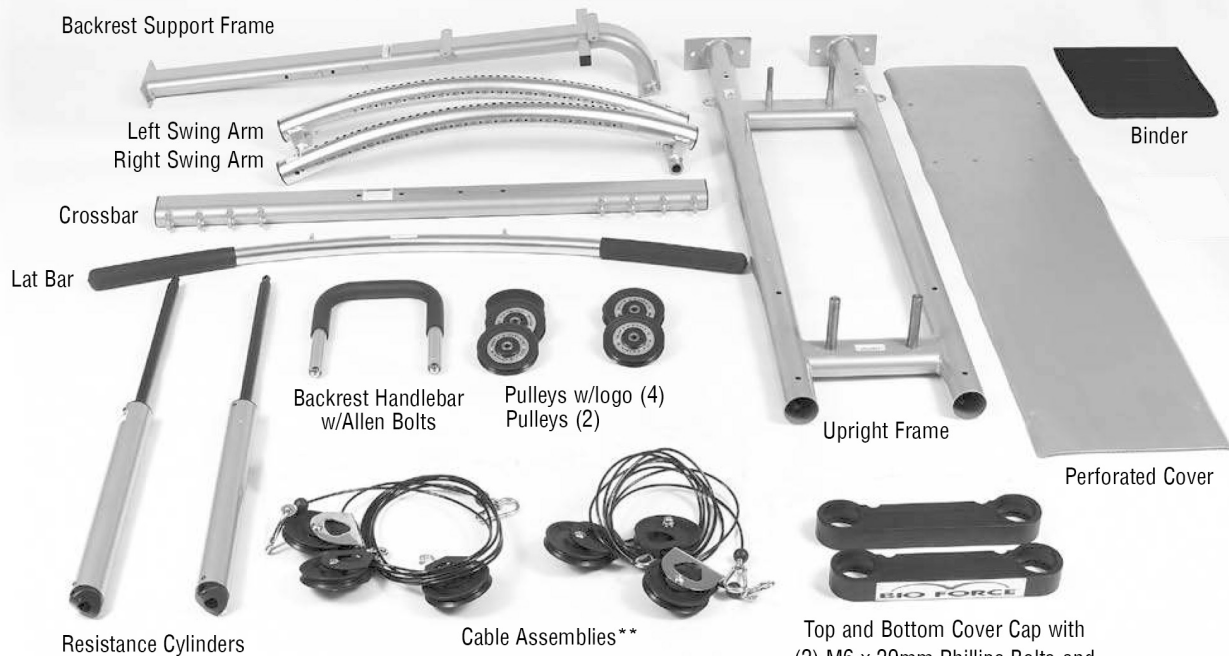

**Important: Each Cable Assembly consists of the Cable, 1 Chrome Pulley and 2 Padded Pulleys

Required parts for step 1:

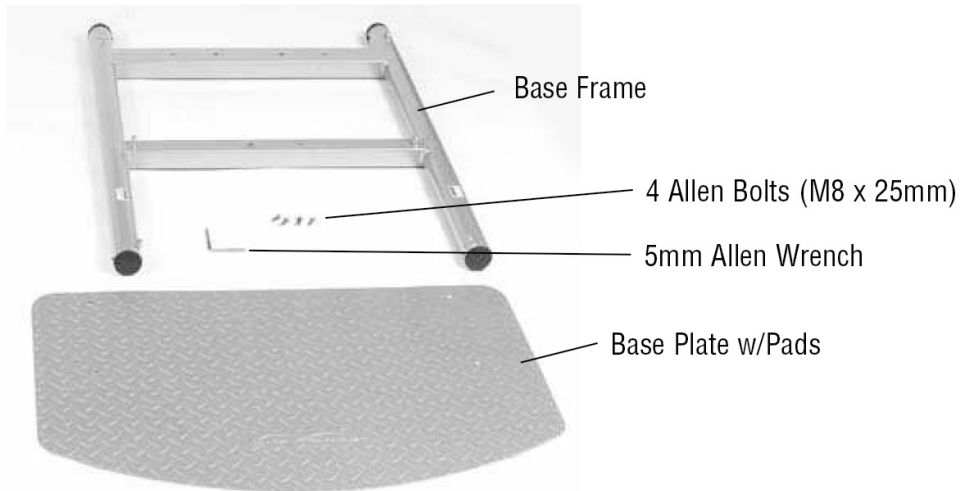

Step 1: Assembly base frame

1. Turn the main frame with the warning notes downward.
2. Position the ground plate on the main frame on the opposite side of the transport wheels and make sure that the bent side of the ground plate shows outward.
3. Align the holes in the ground plate with the main frame and attach the parts with the four screws.

Turn the assembled frame upwards (warning notes point upwards).

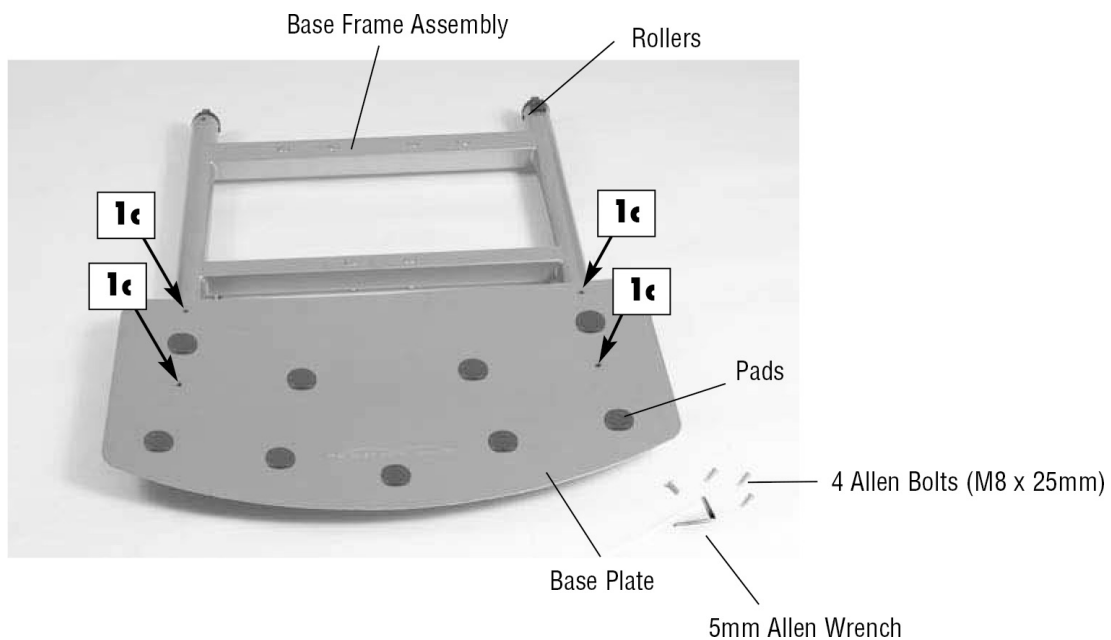

Required parts for step 2:

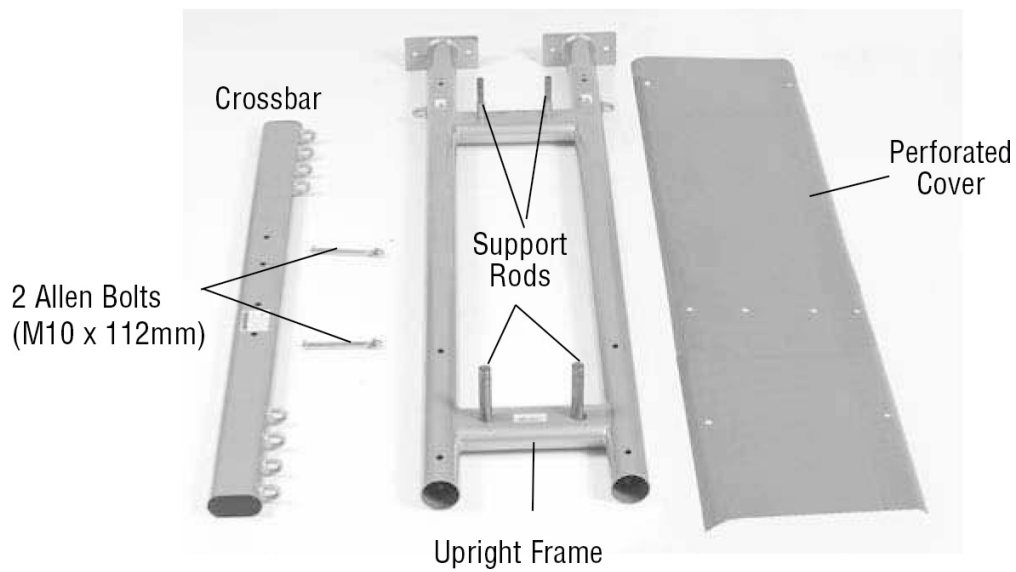

Step 2: Assembly of rear frame

1. Turn around the rear frame so that it is on the auxiliary strut and the warning notes point downwards.
2. Place the perforated cover and the crossbar on the frame and align the holes. The warning notes on the crossbar should point in your direction.
3. Attach the parts by placing the two screws through the exterior holes of the crossbar, the perforated cover and the frame and tighten with two nuts.

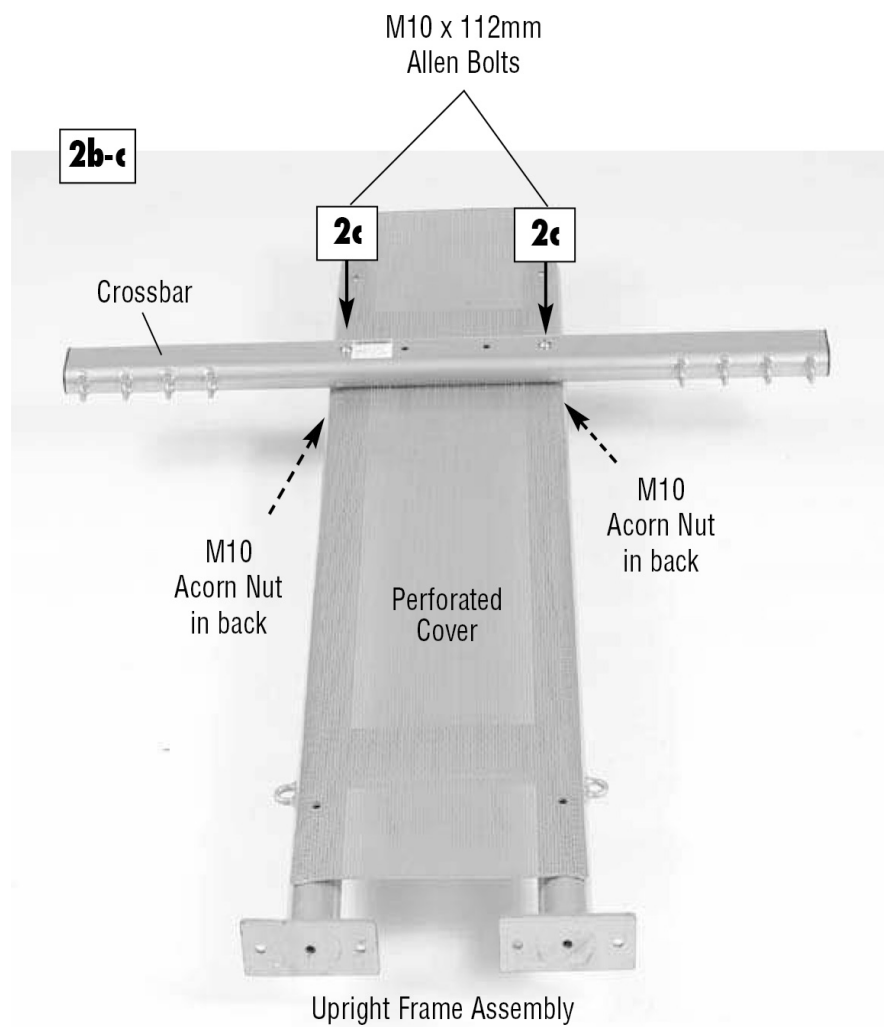

All nuts and screws are brought in from the front to back - with the nut on the backside.

Required parts for step 3:

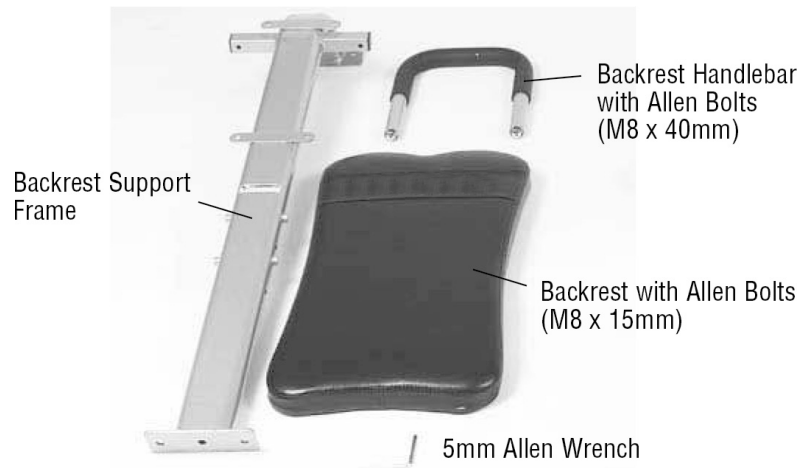

Step 3: Assembly backrest supporting frame

1. Loosen the screws from the handle of the backrest.
2. Mount the handle with the previously loosened screws on the small crossbar on the upper end of the backrest frame. Tighten the screws with the Allen wrench.
3. Turn the backrest and remove the pre-mounted backside.
4. Turn the backrest frame so that the brackets are flat on the backrest. Make sure that the upper end of the backrest (end with the logo) is on the upper end of the frame (end with handle) (see bottom right). Mount the backrest in this position by tightening the Allen screws previously loosened in step 3c.

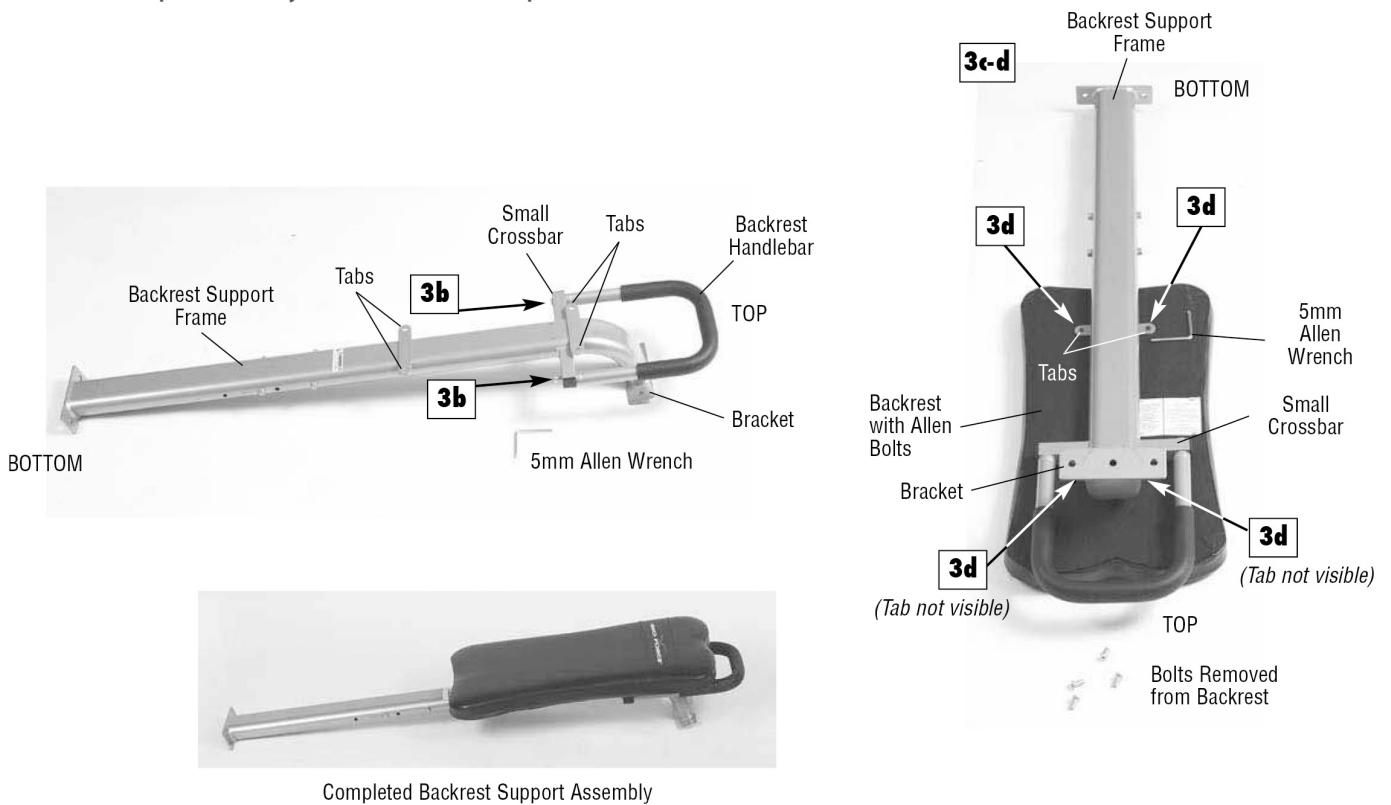

Required parts for step 4:

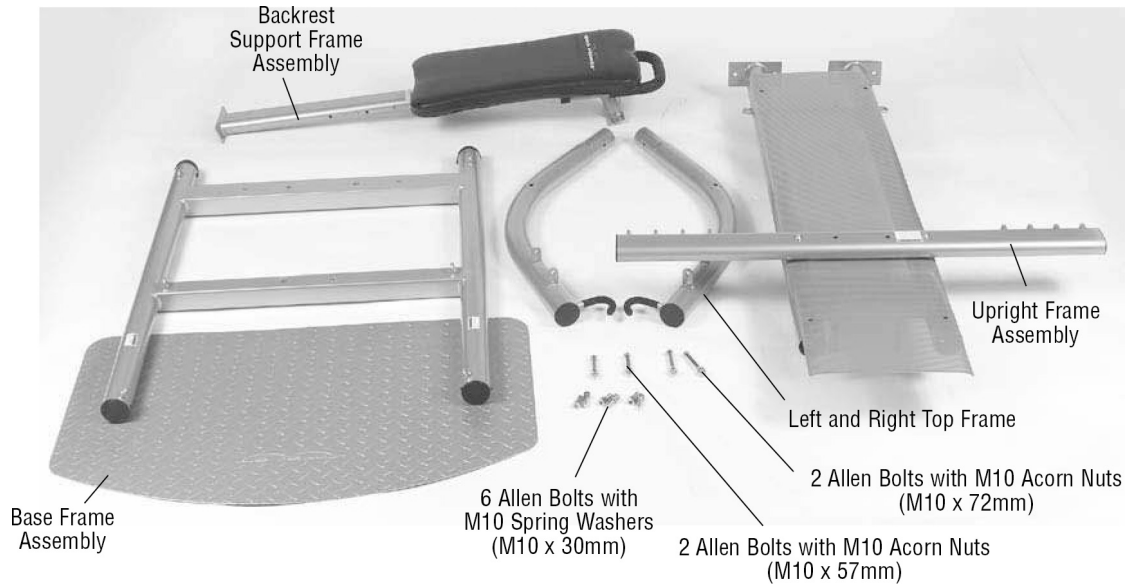

Step 4: Assembly frame components

1. Carefully straighten up the rear frame and place it on the rear traverse of the main frame. The crossbar and the perforated cover point forward. Mount the parts with four screws and spring washers and tighten these by hand.

ATTENTION: This step must be executed with two people.

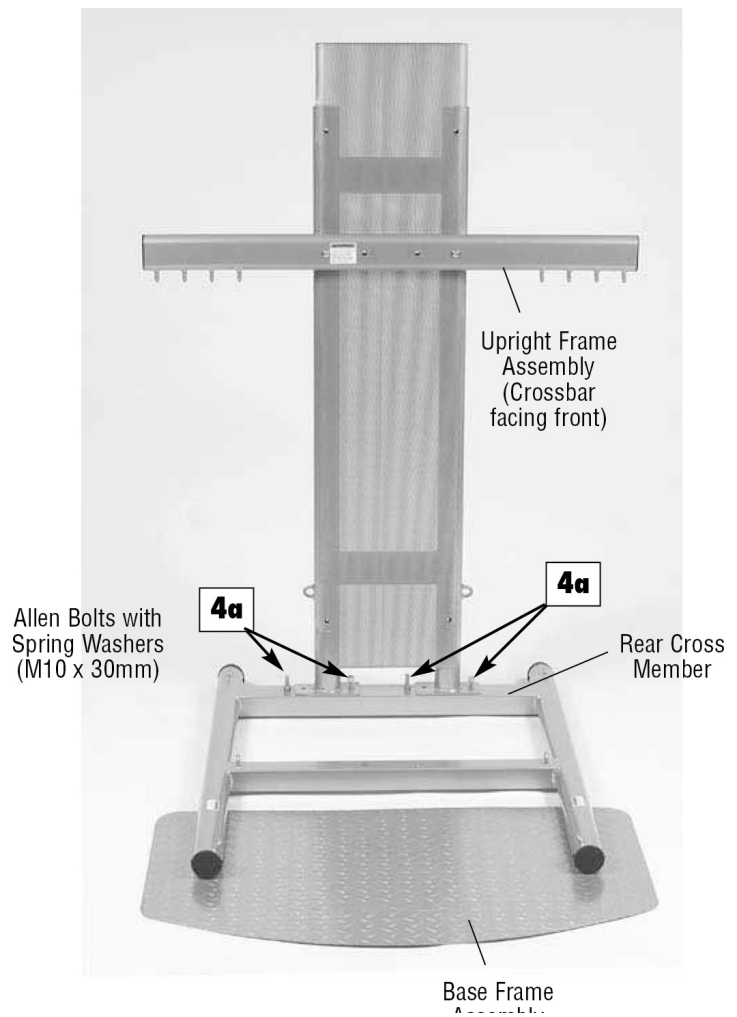

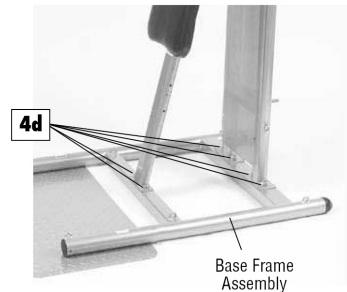
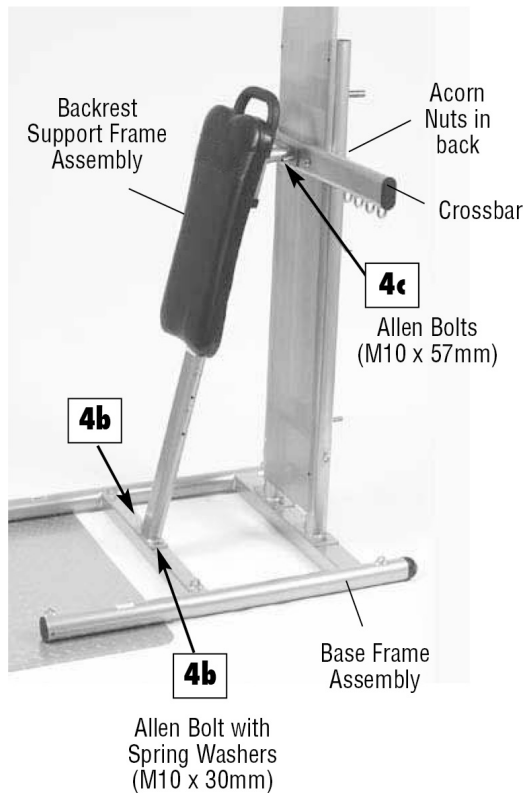

d. With the Allen Wrench, tighten the 6 Base Frame Bolts at this time.

2. Position the frame with the backrest by aligning the holes of the main frame with the holes of the frame with the backrest. Tighten the parts with two screws and spring washers.
3. Align the holes on the upper end of the backrest with the central holes in the crossbar. Mount the two Allen screws and two cap nuts and tighten these by hand.
4. Now tighten the six screws in the base frame with a wrench.
5. Slide the left and right upper frames into the upper end of the main frame, whereby the chrome pulley brackets point inward. Mount the parts with two Allen screws and cap nuts and tighten these by hand.

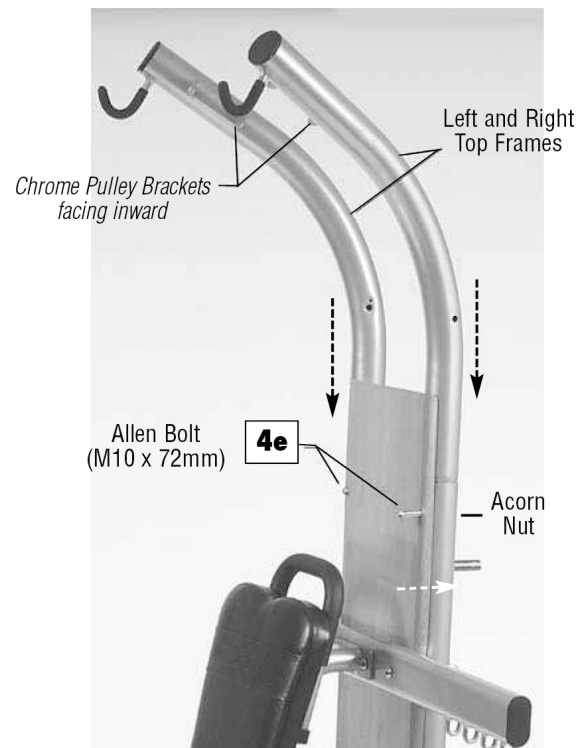

Required parts for step 5:

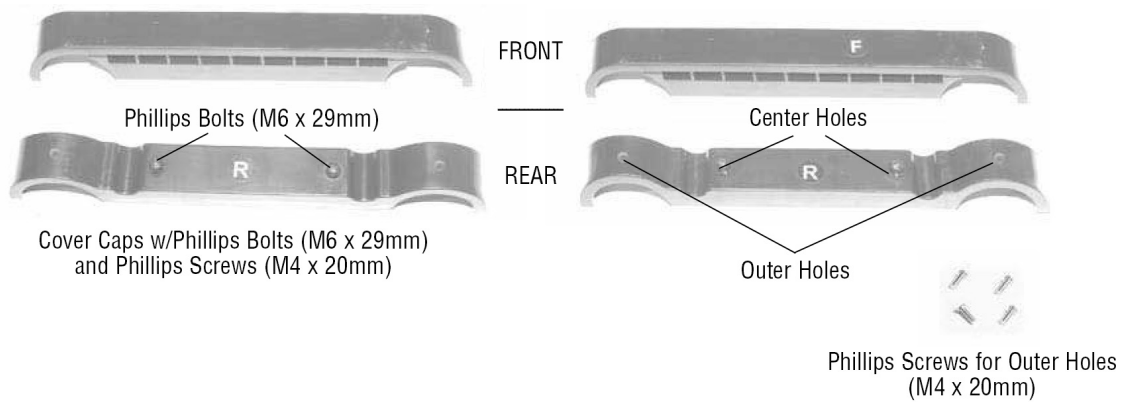

Step 5: Assembly covers

1. Remove the two (M6 x 29mm) hex head screws from the upper cover plates of the perforated metal plate with the Phillips wrench (included in delivery) and separate the front and back sides.

Note: The cover plate with the UltraForce logo belongs on the top on the front side.

2. Mount the front side of the upper cover plate by moving it onto the frame on the edge of the perforated metal plate. The cover plate may have to be pressed down slightly. Then mount the backside of the upper cover plate. Mount the two parts with the previously loosened hex head screws. Mount the backside of the upper cover on the frame with two hex head screws (M4 x 20mm) through the external drill holes. Tighten the screws with the Phillips wrench.
3. Repeat steps 1 and 2 for the lower cover plates.

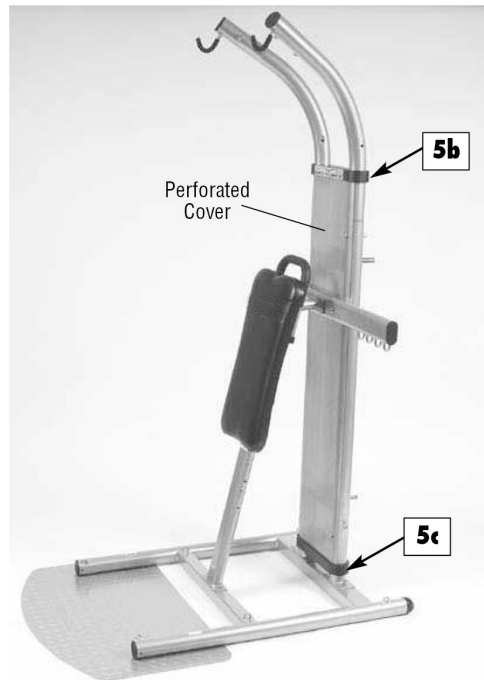

Required parts for steps 6 and 7:

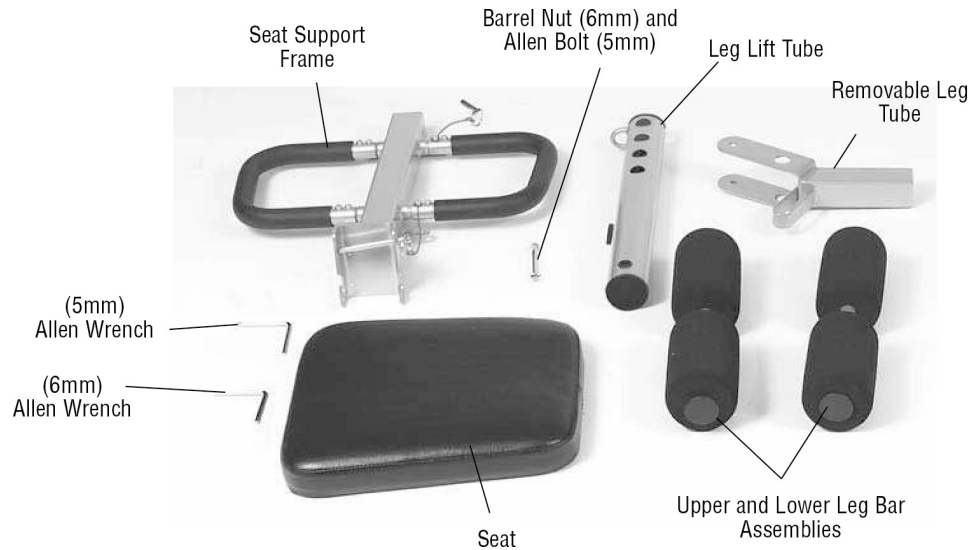

Step 6: Assembly of seat

1. Loosen the screws from the underside of the seat. Place the seat frame on the backside of the seat and make sure that the long socket pin and the bracket are in the same direction as the small end of the seat. Mount the parts with the four previously loosened Allen screws and the 5mm Allen wrench.
2. Remove the long socket pin from the seat frame. Hang the seat on the upper dowel pin from the backrest.

IMPORTANT: Make sure that the bracket on the seat frame is securely placed on the dowel pin. Secure the seat by sliding the long socket pin through the holes under the dowel pin.
3. Remove the short socket pin from the seat frame. Slide the removable leg extension unit in the seat frame as in the figure to the left. Secure the parts by sliding the short socket pin through the seat frame and the leg extension unit.

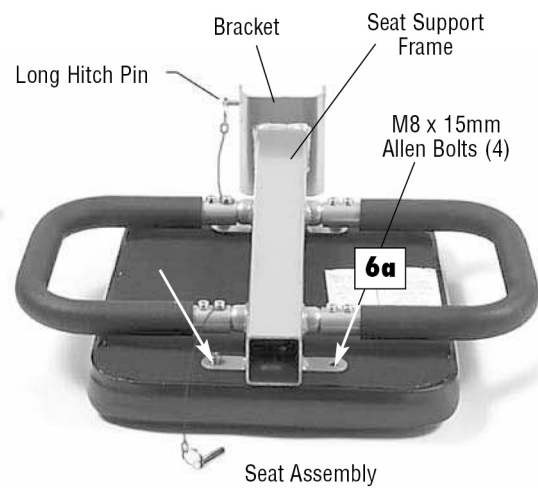
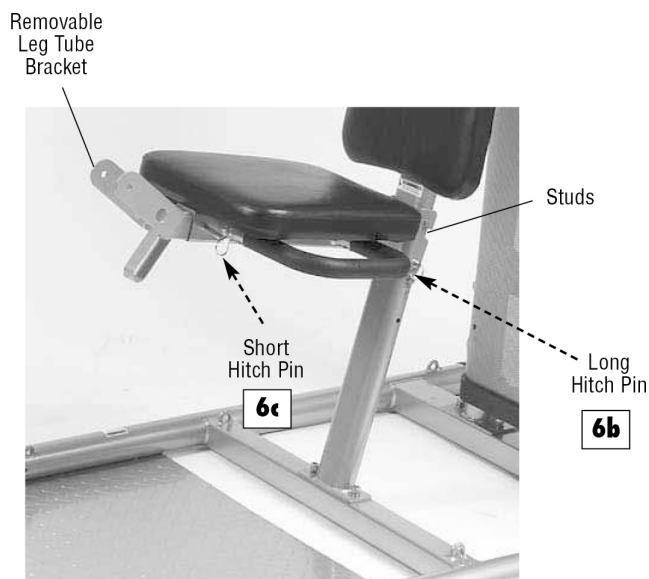

Step 7: Assembly of leg extension

1. Place the upper end of the leg extension tube on the bracket from the removable leg extension unit.

Note: The warning note points towards the seat. Slide the barrel nut through the removable leg extension unit and the leg extension tube. Mount the parts with the Allen screw and the Allen wrench (5&6mm).

2. Remove the cover cap and a foam cushion and slide the upper leg extension bar through the opening in the middle of the bracket of the removable leg extension unit. Slide the foam cushion and the cover cap back on to the leg extension bar.

IMPORTANT: Make sure that the cover cap is correctly placed on the bar.

Note: The upper leg extension bar is longer than the lower one.

3. Remove the cover cap and a foam cushion and slide the lower leg extension bar through the openings on the lower end of the leg extension tube. Slide the foam cushion and the cover cap back on to the leg extension bar.

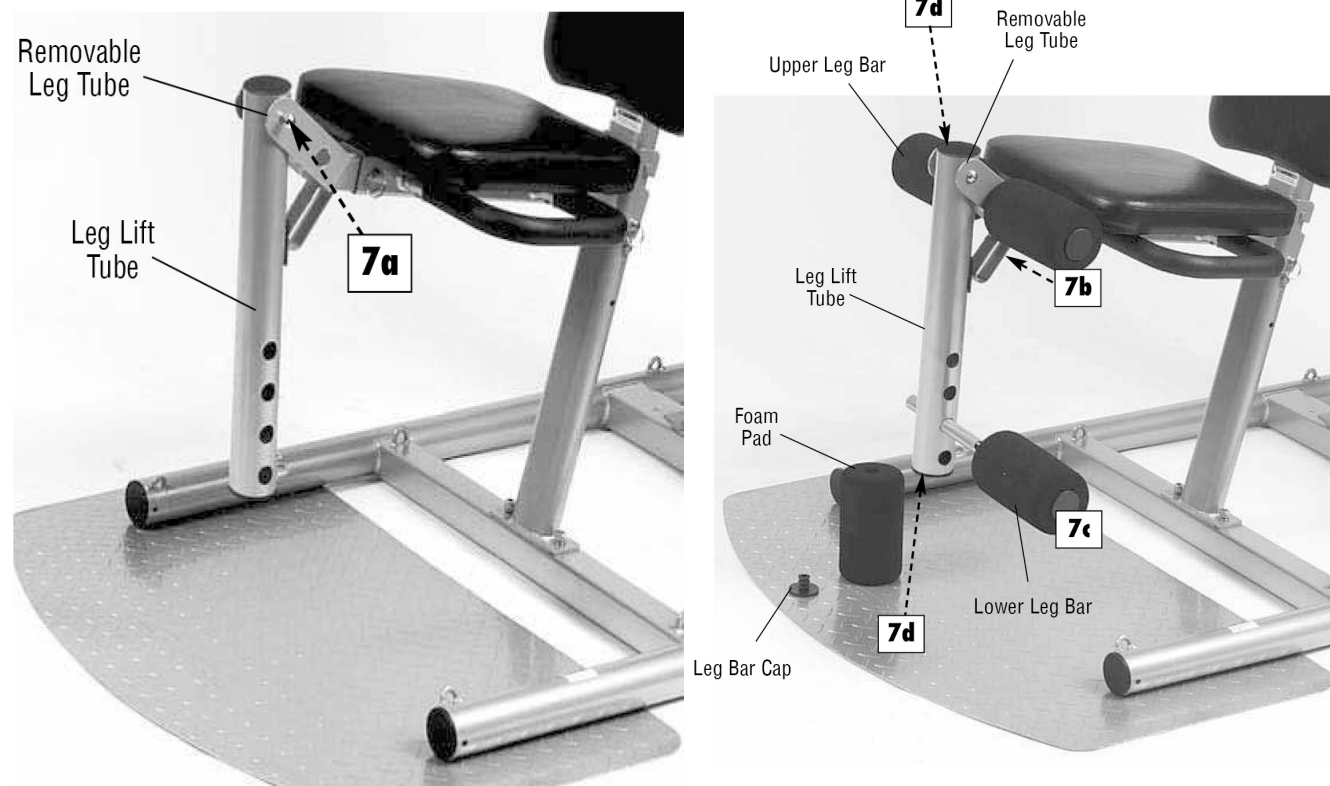

Required parts for step 8:

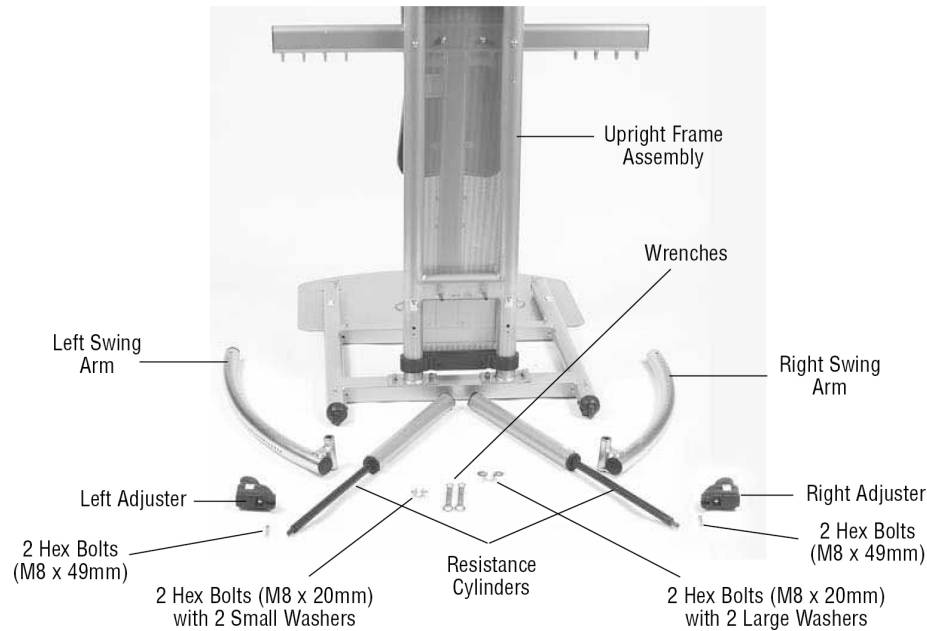

Step 8: Assembly swivel arms and cylinder

Place yourself behind the station.

1. Slide the right swivel arm on the supportive bar on the upper crossbar of the main frame. The label from the swivel arm points forward. Mount the right swivel arm with a large washer and a hex head screw.
2. Lift the knob from the right adjusting unit while you slide it to the swivel arm to number 20. The markings are located on the front side of the swivel arm. The adjusting unit is displayed to the right and left under the knob on the backside. The markings for setting the weight must be visible through the opening on the front side of the adjusting unit.
3. Place the lower end of the resistance cylinder on the supporting bar of the lower crossbar from the main frame. Place the upper end of the cylinder to the outer right. Mount the lower end of the cylinder with a small washer and a hexagon screw.

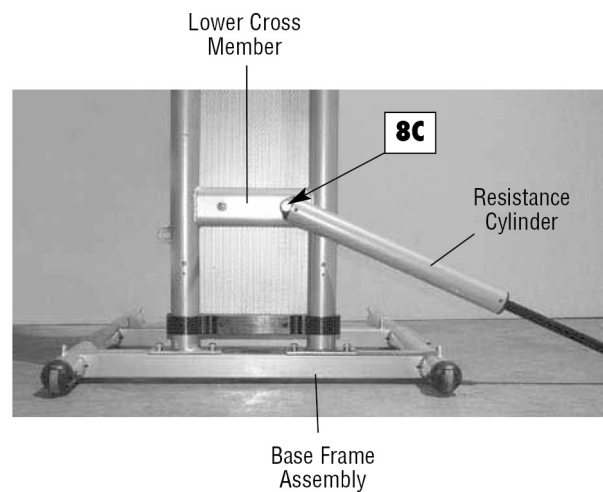
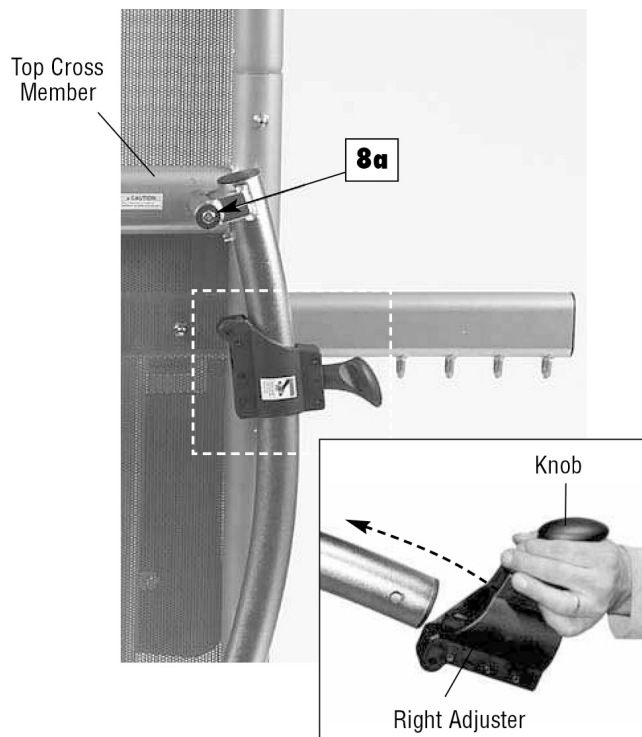

All nuts and screws are brought in from the front to back - with the nut on the backside.

4. Lift the right swivel arm and the resistance cylinder. Mount the upper end of the cylinder with the lower part of the right adjusting unit with a cap nut and a hex head screw. The nut is located on the backside here.
5. Repeat steps 1 to 4 for the left side.

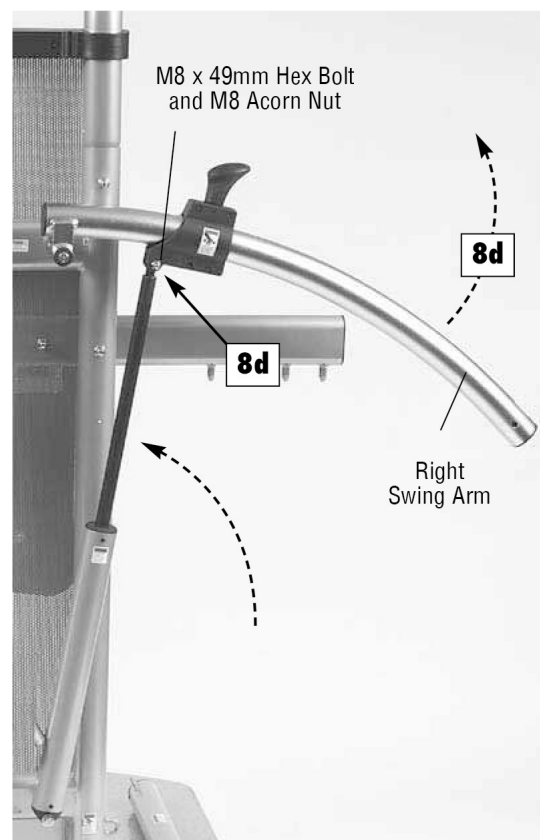

Required parts for step 9:

6 Pulley Brackets
(marked by their
position on the unit)

6 Pulleys

6 Allen Bolts
(M10 x 95mm)

6 Acorn Nuts (M10)



Step 9: Assembly pulleys

1. Determine the positions of the individual pulley holders, see markings.
2. Take the two pulleys without the UltraForce logo and the two pulley brackets, which are designated for the lower end of the main frame. Mount the pulleys on the lower backside of the main frame with two Allen screws and two cap nuts. Do not tighten the screws yet!
3. Take the two pulley brackets for the upper end of the main frame and the two pulleys with UltraForce logos. Mount these parts on the upper main frame with two Allen screws and two cap nuts. The logos are facing each other.
4. Take the two pulley brackets for the swivel arms and the two pulleys with UltraForce logos. Mount these parts on the end of the swivel arms with two Allen screws and two cap nuts. The logos point forward.

Notes for steps 9-2 to 9-4:

- All nuts and screws are brought in from the front to back - with the nut on the backside.
- Make sure that the bracket pins are properly anchored.
- The nuts must first be tightened slightly in order to attach the rope.

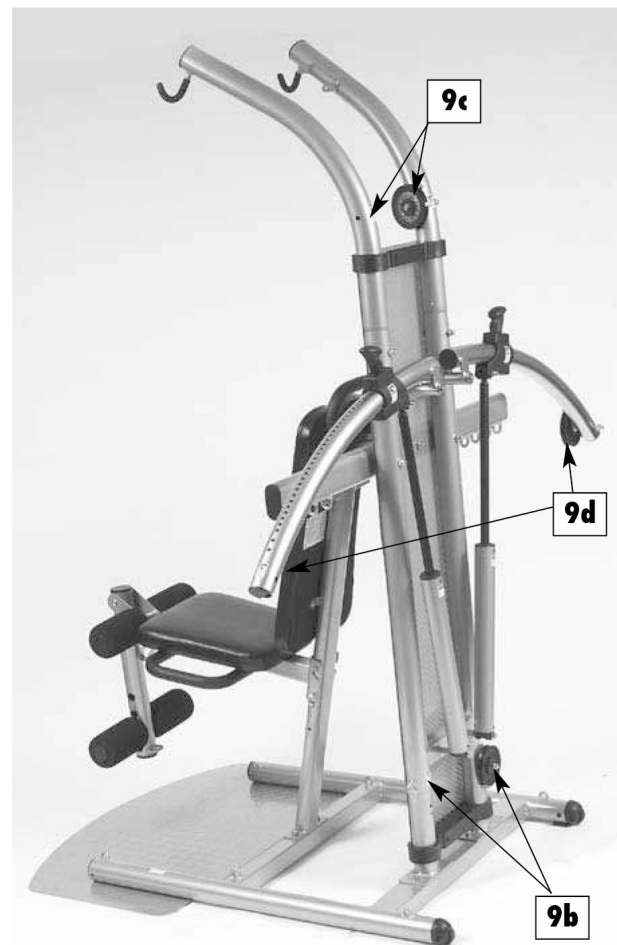
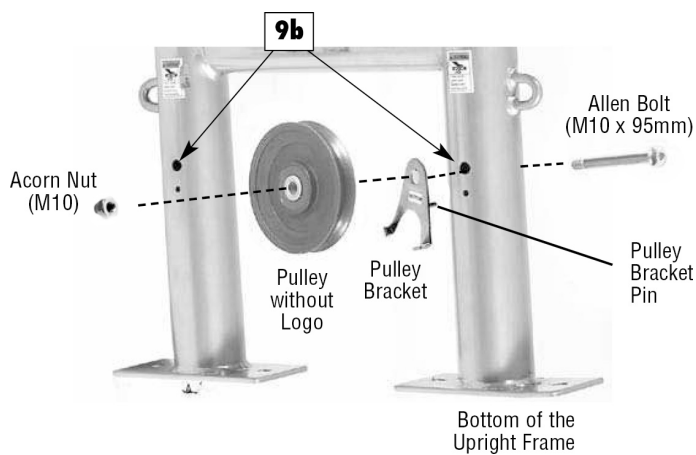

Required parts for step 10:

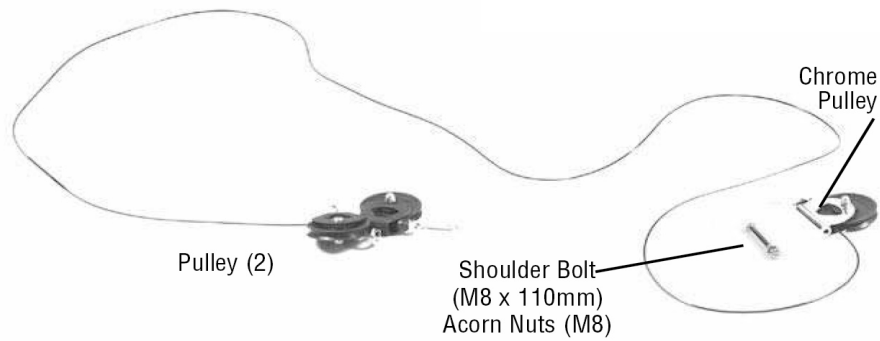

Step 10: Assembly of the cable

1. Lay out and unwind cable. Slide the chrome pulley to one end of the cable. Slide the other two pulleys to the other end of the cable. This keeps the cable unwind during installation.
2. Mount the chrome pulley with bracket on the upper right frame with a thread screw and a cap nut, see image. The large snap hook must be in front and the nut in the back. You must be able to spin the pulley. Note: You may need a ladder for this step.

3. Moving the cable.

Tip: If you attach the cable to previously assembled pulleys, it may be easier if you loosen the nuts and pull out the pulley. After you have guided through the cable, mount the pulley and the bracket again before you continue.

- a. Guide the cable downward through the pulley above the perforated sheet.
 - b. Guide the cable from the outside passing the upper and lower supporting bars and then inside to the lower pulley.
 - c. Guide the cable upward around the pulley to the inner side of the pulley on the swivel arm.
 - d. Guide the cable downward through the pulley on the swivel arm to the hook on the rear side of the main frame.
Hook the pulley on the cable set on the hook on the rear end of the base frame by loosening the Phillips screw until the hook can be mounted on the pulley on the hook from the main frame. Tighten the Phillips screw so that the pulley can not loosen from the hook.
4. Repeat steps 1-3 for the left side.
 5. Now tighten all screws and nuts. Make sure that the cable does not get stuck.
 6. **IMPORTANT:** Now tighten all screws and nuts that were only slightly tightened in the previous steps. The corresponding screws are marked in the figure with a black dot.

M8 x 110mm
Shoulder Bolt

Large Clip

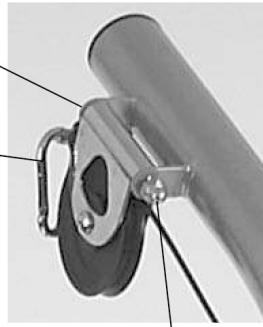

M8 Acorn Nut

10b Chrome
Pulley

Stringing The Cable

*String Cable behind
Swing Arm - to the
outside of the Top and
Bottom Support Rod*

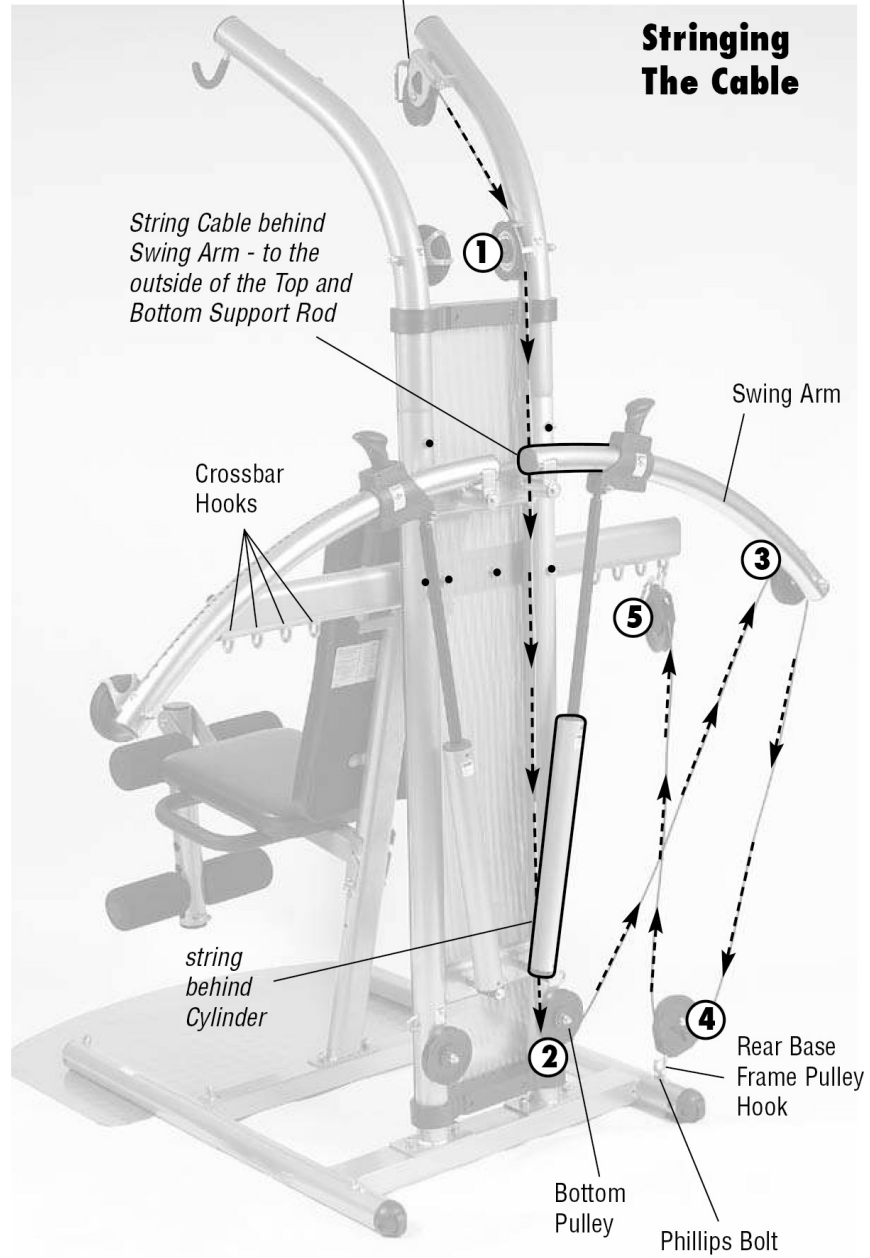

Accessories:

1. Mount the lat bar on the large snap hook on the upper frame. Then place the lat bar in the designated hook on the upper frame.
 2. Mount the handles with the large snap hook on the end of the cable on the crossbar.
- Note:** The foot loops can now be suspended on the hook from the leg extension unit.

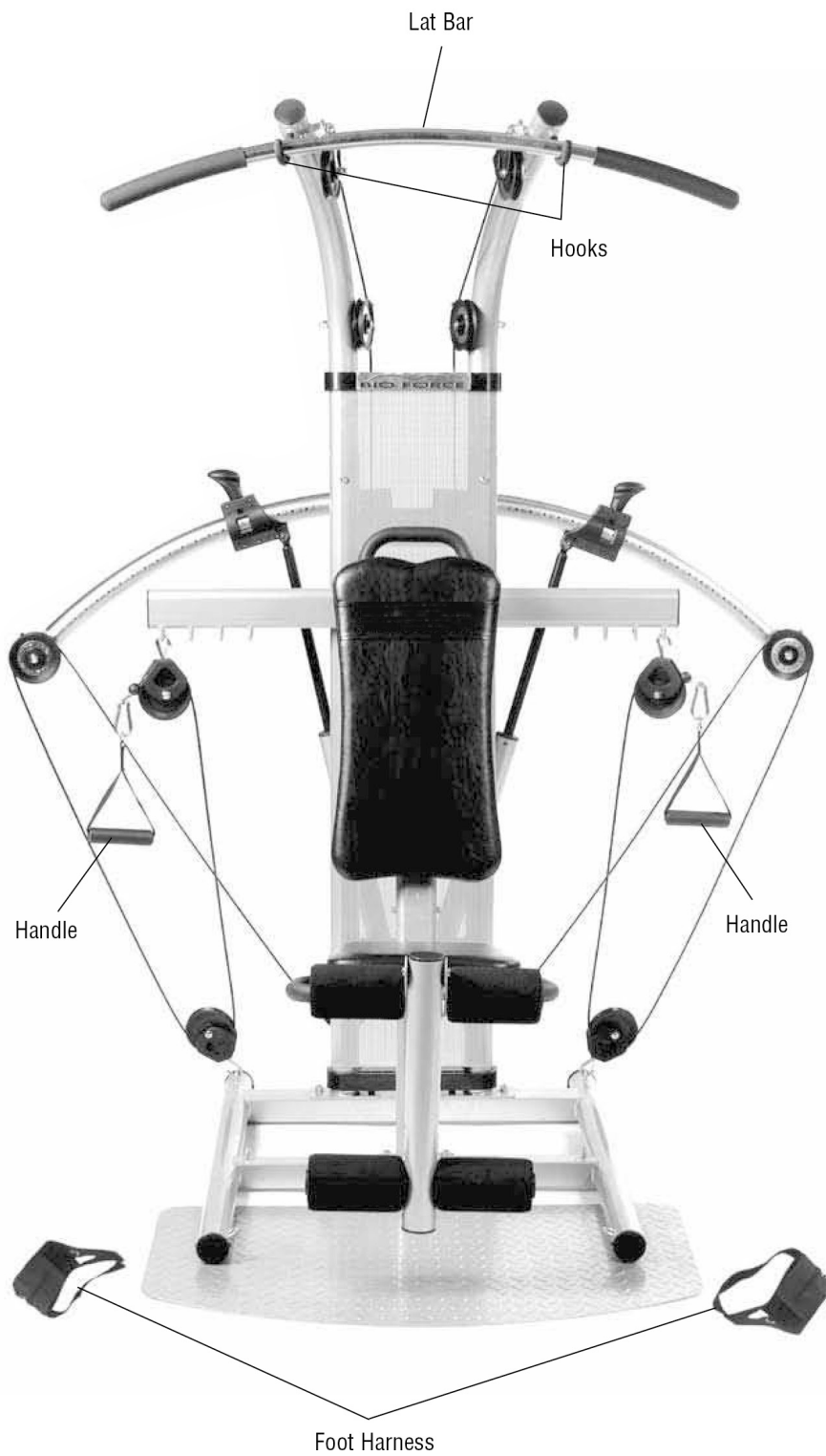

Step 11: Transport

We recommend you use 2 people when moving the equipment.

Make sure nothing is in your way before moving exerciser.

Grab frame securely from behind the Bio Force exerciser, place your foot on the rear cross member (as shown in figure 1), tilt back until wheels engage, roll across the floor to your desired location (figure 2).

Slowly let the front of the Bio Force exerciser down by holding the top of the Frame and placing your foot against the rear cross member until the Frame Plate is on the floor.

ATTENTION: When transporting for storage we recommend two people move this unit.



figure 1



**We recommend
you use 2 people
when moving the
equipment.**

figure 2

The Taurus UltraForce is a multi-functional multi-gym for achieving many training targets. Muscle toning and tightening are possible as well as an improvement of strength-endurance and an effective support in losing weight. We have compiled some important training tips for you so you can achieve your training targets as effectively, safely and lastingly as possible.

4.1 General training instructions

IMPORTANT Please read through this section before you begin training.

IMPORTANT: If you are older than 35 years and have not trained for several years, consult your physician and they will recommend an assessment test. Your physician can support you in determining the target heart rate zone corresponding to your age and fitness level as well.

You should also consult your physician in the event of:

- High blood pressure
- High cholesterol values
- Asthma
- Heart problems
- (Death through) strokes or heart attacks in your family history
- Frequent cases of dizziness
- Extreme breathing problems after slight strain
- Arthritis or other bone problems
- Serious muscle/ligament/or tendon problems
- Other known or presumed illnesses
- If you feel pain or tension in the breast, feel an irregular heart beat or are short of breath, stop training immediately. Consult your physician before you continue.
- Pregnancy
- Balance impairments
- Taking medicine that affects your heart rate.

Warm-up

We recommend starting every training session by warming up in order to prevent injuries and to maximize performance. Your warm-up phase prepares your muscles softly for the load. Begin with five to 10 minutes of soft exercises (e. g., walking) that gradually increase your heart rate and loosen up your muscles. The warm-up phase should be aerobic and require a slight, unconstrained range of movement. This should be followed by five to 10 minutes of stretching (see page 38 in these instructions or in the included training instructions). Never bring your body beyond the point of soft tension or strain. Make sure to have soft, rhythmic, controlled movements.

Clothing

All training clothing should sit loosely and comfortably (for enough freedom of movement) and give self-confidence. Never wear rubber and synthetic clothing; such materials impair the evaporation of sweat and may cause a dangerous increase in body temperature. Wear comfortable, supportive sport shoes with anti-slip soles like running or aerobic shoes.

Motivation tips

1. Create a plan and write it down.
2. Set realistic goals and remind yourself of them often.
3. Keep a journal in order to record your progress and update it regularly. See tables in these instructions.
4. Write down your weight and/or body fat percentage measurements in the journal.
5. Get support and participation from family and friends.
6. Keep other people up to date about your success.
7. Avoid injuries through adjustments including warm up and cool down phases as a part of your daily workout.
8. Reward yourself in regular intervals for a job well done!

4.2 Exercise and safety notes

- 1.) Carefully and completely go through these user instructions and the included training instructions before you start a training program. Remember to follow the instructions exactly. These were developed with your health and safety in mind.
- 2.) Execute all exercises in a slow and controlled manner. Execute all exercises at the speed specified in the training instructions in order to achieve the best results. Training at a high pace is not recommended and may impair your safety and results.
- 3.) You may not be able to completely finish all sets and repetitions at first. If you feel fatigue in your muscles or if you cannot train in a good condition and with the corresponding techniques, lower the resistance level or take a short break and cool down.
- 4.) Record the number of sets and repetitions that you can initially do for each exercise. You will be surprised how fast you can make progress. Within a few weeks, it will be possible for you to execute all sets and repetitions at your selected resistance level.
- 5.) Take it slow. If you are tired and emaciated after training, you are training at a level that is too high. You can achieve good results with training that challenges you, but does not cause pain or excessive tiredness.
- 6.) Make sure you know how to execute safe and appropriate training. These safety measures are for your benefit and you should follow them exactly in order to maximize the effectiveness of your training routine.
- 7.) You will feel the results of your training with this equipment within one to two weeks. Pay attention to a better posture and you will find more power and effectiveness in your muscles.

4.3 Exercise manual

A detailed description of all exercises can be found in the included training instructions.

4.4 Equipment settings

Set resistance with glide-n-lock technology

The resistance setting is done quickly. Simply pull up the glide-n-lock slider to unlock it from its current position. Hold the slider up and move it into the desired weight setting and then let go of the slider. Make sure that the locking mechanism has locked in the new resistance position. Make sure that the resistance indicator is red.

Seat adjustment

The UltraForce seat allows for two sitting heights. If you are tall, you may prefer the lower position in order to reach the complete range of movement of the exercises with the lat tower. If you are smaller, you may prefer the higher position in order to be able to grab the lat bar easier. You can choose. If you would like to change the position, remove the long socket pin and pull the seat up in order to unlock it from the position pins. Set it to the new position and place the seat back on the position pins. As soon as it is at the desired position, insert the long socket pin again to lock it.

Do not use the seat if the long socket pin is not inserted.

Adjust leg piece

The lower foam upholstery on the leg extension tube has four positions. These are adjusted to the user's leg length and comfort.

In order to change the foam upholstery, simply remove the leg bar cap at the end of the upholstery. Remove the foam cushion on the side. Now push the tube and remaining upholstery from the leg assembly hole. Set it to the new desired position. Attach the leg bar cap and the first foam upholstery again. Make sure that the leg bar cap is installed securely again.

UltraForce positions of the pulleys

The UltraForce equipment uses a simple system of cables, pulleys and hooks in order to be able to execute over 100 exercises. Below you can see a diagram that shows you the possibilities for the mobile positions of the pulleys and accessory hooks.

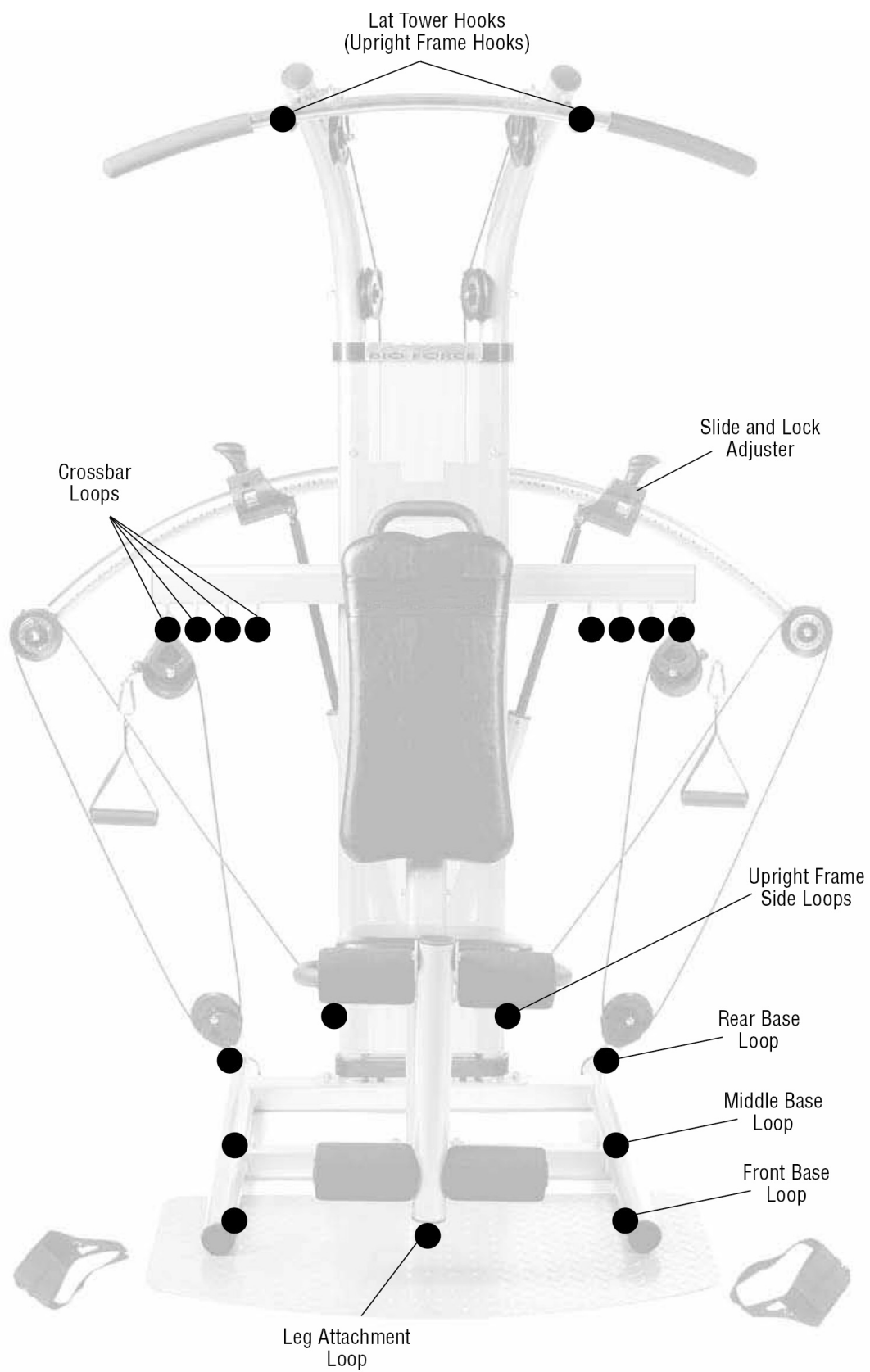

4.5 Stretching exercises for leg & chest muscles

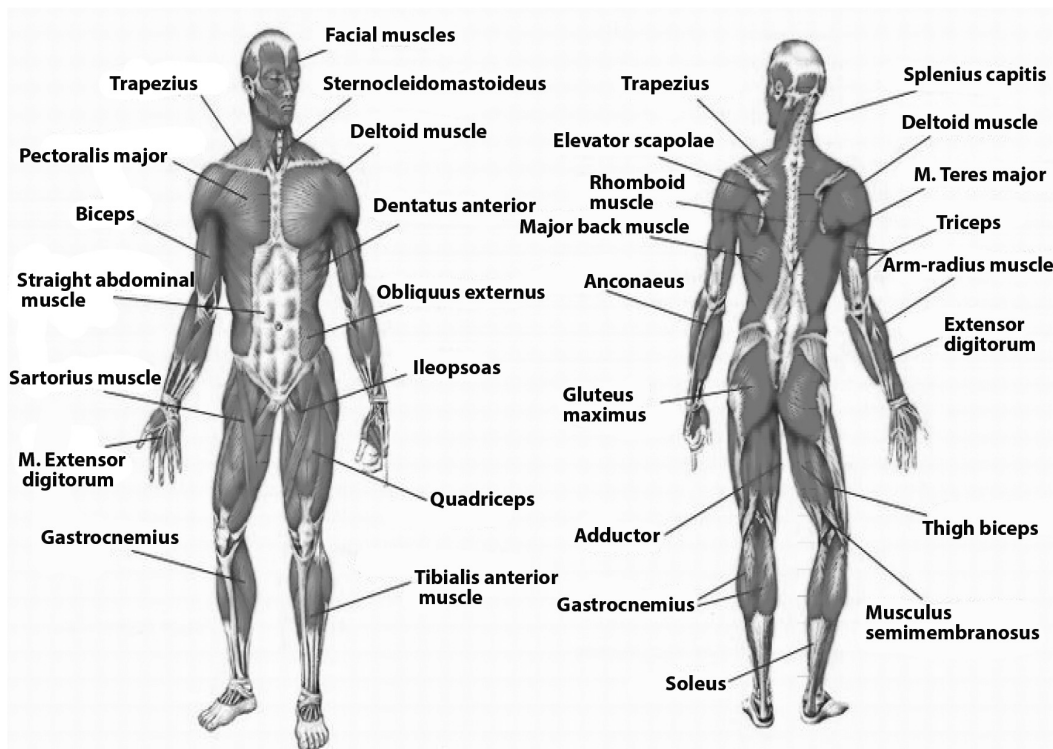

1. Exercise: Stretching of front thigh / leg extension (quadriceps)

- Stable position, grab arches of feet
- Pull heel towards buttocks, knee points downwards (no abduction)
- Straight upper body, avoid tilting the pelvic forward (hollow back) by tensing the abdominal muscles
- Change legs

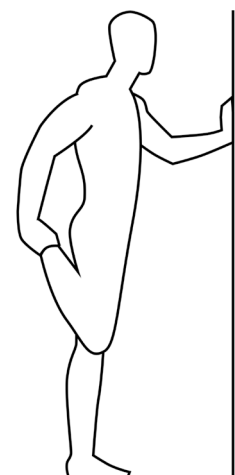

2. Exercise: Stretching the back thigh / leg curl (hamstring)

- Pull thigh towards upper body with both hands
- Stretch through increased stretching in the knee joint
- The lower leg maintains contact with the floor, keep hips bent
- Change legs

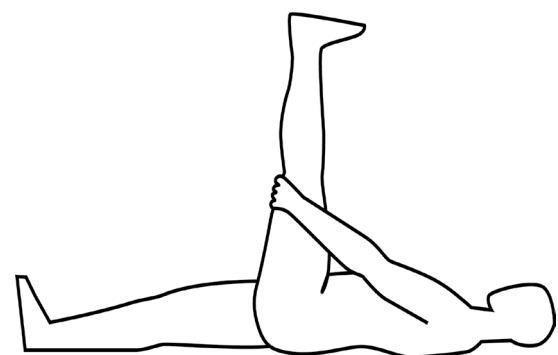

3. Exercise: Stretching the calf muscles (gastrocnemius)

- Place feet parallel to each other pointing forward, the heels touch the floor
- Support yourself on a chair coming from a lunge
- Move your body weight to the front leg, press your heel from the rear leg towards the floor and hold the contact
- Slowly stretch your knee of the rear leg until you feel the stretch in your calves
- Change legs

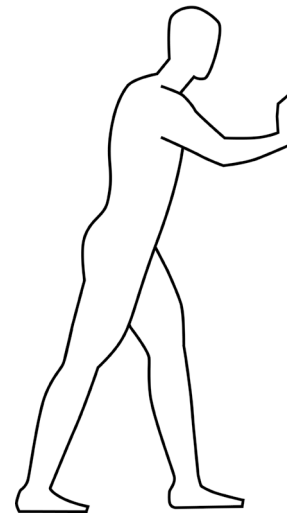

4. Exercise: Stretching the chest muscles (pectoralis major)

- Stand parallel to a wall
- Place your forearm at 90° to the wall with the elbow just above shoulder height
- Turn your head and upper body gradually to the opposite sides until you feel a stretch in the front chest, of the shoulder being leaned on
- Pay attention to tension in your abdominal and gluteal muscles
- Your weight is on your front leg
- Change legs

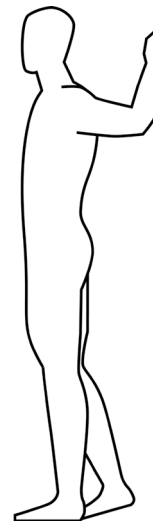

All recommendations of these instructions apply solely to healthy persons and are not suitable for those with heart or cardiovascular problems. All of the tips are intended only as a guide to help you create a workout. Your physician can offer appropriate advice for particular, personal requirements.

We hope you enjoy your workout and have a lot of success!

5 WARRANTY INFORMATION

Taurus fitness equipment is subject to strict quality controls. However, if a fitness equipment purchased from us does not work perfectly, we take it very seriously and ask you to contact our customer service as indicated. We are happy to help you by phone via our service hotline.

Error descriptions

Your fitness equipment is developed for long-term, high-quality training. However, should a problem arise, please first read the operating instructions. For further assistance, please contact your contract partner or call our service hotline. To ensure your problem is solved as quickly as possible, please describe the defect as exactly as possible.

In addition to the statutory warranty, we provide a warranty for every fitness equipment purchased from us according to the following provisions.

Your statutory rights are not affected.

Warranty

The warranty is the first/original buyer and/or any person who received a newly purchased product as a gift from the original buyer.

Warranty periods

The following warranty periods begin on delivery of the fitness equipment.

Model	Use	Full warranty
UltraForce	Home use	24 months

Repair costs

According to our choice, there will either be a repair, a replacement of individual damaged parts or a complete replacement. Spare parts, that have to be mounted while assembling the equipment, have to be replaced by the warranty person personally and are not a part of repair. After the expiration of the warranty period for repair costs, a pure parts warranty applies, which does not include the repair, installation and delivery costs.

The terms of use are defined as follows:

- Home use: solely for private use in private households up to 3 hours per day
- Semi-professional use: up to 6 hours per day (e. g. rehabilitation centers, hotels, clubs, company gyms)
- Professional use: more than 6 hours per day (e. g. commercial gyms)

Warranty service

Within the warranty period, equipment which develops faults as a result of material or manufacturing defects, will be repaired or replaced at our discretion. Ownership of equipment or parts of equipment which have been replaced is transferred to us. The warranty period is not extended nor does a new warranty period begin following repair or replacement under the warranty.

Warranty conditions

For the warranty to be valid, the following steps must be taken:

Please contact our customer service by email or phone. If the product under warranty has to be sent in for repair, the seller bears costs. After expiry of the warranty, the buyer bears the costs of transport and insurance. If the fault is covered by our warranty, you will receive a new or repaired equipment in return.

Warranty claims are invalid in case of damage resulting from:

- misuse or improper handling
- environmental influences (moisture, heat, electrical surge, dust, etc.)
- failure to follow the current safety measures for the equipment
- failure to follow the operating instructions
- use of force (e. g. hitting, kicking, falling)
- interventions which were not carried out by one of our authorized service centers
- unauthorized repair attempts

Proof of purchase and serial number

Please make sure that you are able to provide the appropriate receipt when claiming on your warranty. So that we can clearly identify the model of your equipment, and for the purposes of our quality control, you will need to give the serial number of your equipment, when contacting the service team. Where possible please have your serial number and your customer number ready when you call our service hotline. It will help us to deal with your request swiftly.

If you have trouble finding the serial number on your fitness equipment, our service team is at your disposal to offer further information.

Service outside the warranty period

We are also happy to issue an individual cost estimate if there is a problem with your fitness equipment after the warranty has expired, or in cases which do not fall under the terms of the warranty, e. g. normal wear and tear. Please contact our customer service team to find a quick and cost-effective solution to your problem. In such a case you will be responsible for the delivery costs.

Communication

Many problems can be solved just by speaking to us as your specialist supplier. We know how important it is to you as a user of the fitness equipment to have problems solved quickly and simply, so you can enjoy working out with minimal interruption. For that reason, we also want to resolve your queries quickly and in a straightforward manner. Thus, please always keep your customer number and the serial number of the faulty equipment handy.

6 DISPOSAL

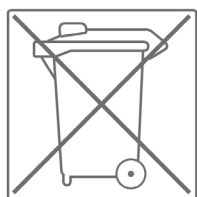

At the end of its operational life, this equipment cannot be disposed of in normal household waste. Instead, it must be disposed of via an electricals recycling centre. Further information can be obtained from your local authority's recycling service.

The materials can be recycled as per their symbols. Through the reuse, recycling of materials or other forms of recovery of old equipment, you make an important contribution to the protection of the environment.

7 ORDERING ACCESSORIES

	<p>Sport-Tiedje handgrip for strength training Art. No. ST-HG-020</p>
	<p>Sport-Tiedje floor mat set Art. No. TF-FMS-B</p>
	<p>GYMWATCH Sensor Art. No. GW-SENSOR</p>
	<p>Sport-Tiedje silicone spray Art. No. ST-1003</p>

8 ORDERING SPARE PARTS

8.1 Service hotline

So that we can give you the best possible service, please have your **model name, part number, serial number, exploded drawing and parts list** ready.

SERVICE-HOTLINE

DE ☎ +49 4621 4210-0 🖨 +49 4621 4210-699 ✉ service@sport-tiedje.de Mon - Fri 8:00 am - 6:00 pm Sat 9:00 am - 6:00 pm	NL ☎ +31 172 619961 ✉ info@fitshop.nl Mon - Thu 9 am - 5 pm Fri 9 am - 9 pm Sat 10 am - 5 pm	UK ☎ +44 141 876 3972 ✉ orders@powerhousefitness.co.uk Mon - Fri 9 am - 5 pm
--	--	--

8.2 Serial number and model name

Before assembling your equipment, find the serial number on the white sticker and enter it in the appropriate space.

Serial number:

Brand / category:

Model name:

8.3 Parts list

No.	Description	Qty.
1	UPRIGHT FRAME	1
2	PULLEY WHEEL WITH LOGO PLATE	4
3	TAPPING SCREW q;2x4mm	12
4	PULLEY WHEEL	8
5	REARING	12
6	PLASTIC PULLEY COVER	12
7	OIL BEARING	24
8	BOTTOM PULLEY BRACKET	2
9	PERFORATED COVER	1
10A	FRONT TOP COVER CAP	1
10B	FRONT BOTTOM COVER CAP	1
11	REAR COVER CAP	2
12	ALUMINIUM LOGO PLATE	1
13	M4X10 PHILLIPS BOLT (TAPPING SCREW q;3.5x10mm)	12
14	M60 ROUND TUBE CAP	6
15	PHILLIPS BOLT M6x29mm	4
16	BACKREST SUPPORT FRAME	1
17	CROSS BAR	1
18	BACKREST HANDLEBAR	1
19	FOAM GRIP q;31.4xq;25.4x450	1
20	ALLEN BOLT M8x40mm	2
21	1" SQUARE TUBE CAP	2
22	OVAL END CAP	2
23	RUBBER PADDER-PULLEY SHROUD	4
24	BOLT M10x47mm(THREAD LENGTH 12mm)	4
25	ACORN NUT M10	20
26	BASE FRAME	1
27	BASE PLATE	1
28	BASE PLATE PAD	3
29	ROLLER	2
30	PLASTIC ROLLER CAP(L)	1
31	PLASTIC ROLLER CAP(R)	1
32	ALLEN BOLT M8x46mm(THREAD LENGTH 10mm)	2
33	PHILLIPS SCREW M6x20mm	1

No.	Description	Qty.
34	BASE FRAME PAD	2
35	PHILLIPS SCREW M4X20mm (TAPPING SCREW q;4x20mm)	6
36	TOP FRAME TUBE (L)	1
37	PULLEY WHEEL(A) WITH LOGO PLATE	4
38	CHROME PULLEY ASSEMBLY	2
39	ALLEN BOLT M10x38mm(THREAD LENGTH 10mm)	2
40	TOP FRAME TUBE (R)	1
41	TOP PULLEY WHEEL BRACKET (L)	1
42	FOAM GRIP <t14x<t12x125	2
43	SWING ARM ASSEMBLY BRACKET (L)	1
44	OIL BEARING	4
45L	CALIBRATION STICKER(L)	1
45R	CALIBRATION STICKER(R)	1
46	TUBE CAPq;50.8mm	4
47	LEFT ADJUST SHROUD (LF)	1
48	LEFT ADJUST SHROUD (LR)	1
49	ADJUSTER PLASTIC WHEEL	12
50	ADJUSTER PLASTIC WHEEL	4
51	SPRING LOADED ADJUST KNOB	2
52	SPRING SEAT BLOCK	2
53	ADJUSTER SPRING	2
54	AXLE PIN	2
55	IRON STRIP PIN	2
56	ADJUSTER PULLEY	2
57	ADJUSTER IRON STRIP AXLE PIN	6
58	ALLEN BOLT M5x32mm	10
59	NYLON NUT M5	10
60	ADJUSTER T SHAPED SEAT BUSHING	2
61	SWING ARM ASSEMBLY BRACKET (R)	1
62	SWING ARM PULLEY WHEEL BRACKET WITH BUSHING(L)	1
63	SWING ARM PULLEY WHEEL BRACKET WITH BUSHING(R)	1
64	TOP PULLEY WHEEL BRACKET(R)	1
65	RESISTANCE CYLINDER	2
66	RESISTANCE IRON CORE	2

No.	Description	Qty.
67	CYLINDER HOUSING TUBE	2
68	RESISTANCE PLASTIC CAP	2
69	RESISTANCE PLASTIC CAP W/PIVOT	2
70	CABLE	2
71	LARGE CLIP	4
72	HANDLES	2
73	SEAT SUPPORT FRAME	1
74	SEAT HANDLE BAR	2
75	SEAT HANDLE BAR GRIPS <t31.4x<t25.4x470	2
76	ALLEN BOLT M6x12mm	8
77	SPRING WASHER	8
78	REMOVABLE LEG TUBE	1
79	BUMPER	1
80+118	SHORT HITCH PIN WITH LANYARD	1
81+118	LONG HITCH PIN W/LANYARD	1
82	LEG LIFT TUBE	1
83	LOWER LEG BAR(SHORT)	1
84	UPPER LEG BAR(LONG)	1
85	FOAM PADS <t90x<t22.2x165	4
86	LEG BAR CAP <t22.2	4
87	PLASTIC BUSHING	2
88	LAT BAR	1
89	LAT BAR CAP <t31.8	2
90	LAT BAR FOAM GRIP <t31.8x<t37.8x275	2
91	RIGHT ADJUSTER SHROUD (RF)	1
92	LEFT ADJUSTER SHROUD (RR)	1
93	ALLEN BOLT M8x15mm(SEAT BACK REST)	8
94	FOOT HARNESS	2
95	SMALL CLIP	2
96	ALLEN Bolt M10x72mm(THREAD LENGTH 15mm)	2
97	ALLEN Bolt M10x112mm(THREAD LENGTH 20mm)	2
98	ALLEN Bolt M10x57mm(THREAD LENGTH 15mm)	2
99	ALLEN Bolt M10x30mm	6
100	SPRING WASHER M10x2.5t	6

No.	Description	Qty.
101	HEX BOLT M8x20mm	4
102	M9 LARGE WASHER q;30xq;9x2.0t	2
103	M9 SMALL WASHER q;20xq;9x2.0t	2
104	HEX BOLT M8x49mm(THREAD LENGTH 10mm)	2
105	ACORN NUT M8	2
106	ALLEN SPACER BOLT	1
107	ALLEN BOLT 5mm	1
108	ALLEN BOLT M10x98mm(THREAD LENGTH 15mm)	6
109	ALLEN BOLT M10x115mm(THREAD LENGTH 15mm)	2
110	ALLEN BOLT M8x25	4
111	ALLEN WRENCH 6mm	1
112	ALLEN WRENCH 8mm	1
113	ALLEN WRENCH+SCREW DRIVER 5mm	1
114	SEAT	1
115	BACKREST	1
116	HEX WRENCH	2
118	LANYARD	2
119	PHILLIPS BOLT M5*4	2
120	RUBBER PADDING PULLEY SHROUD	2
121	PHILLIPS BOLT M5*20	2

8.4 Exploded drawing

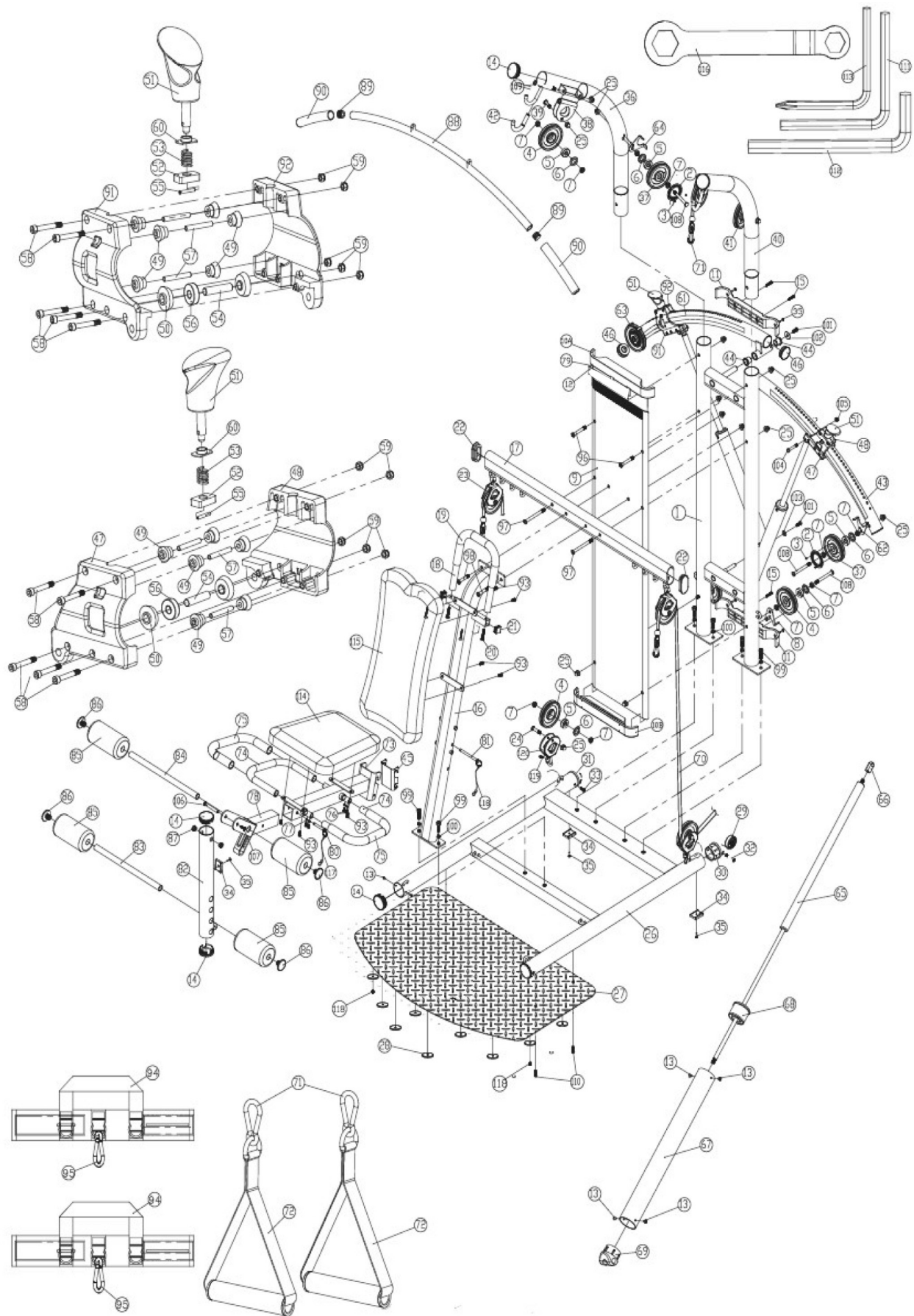

CONTACT

Company head office

Sport-Tiedje GmbH
Flensburger Str. 55
24837 Schleswig
Germany

GENERAL INFORMATION:

DE ☎ +49 4621 4210-0
✉ info@sport-tiedje.com

NL ☎ +31 172 619961
✉ info@fitshop.nl

UK ☎ +44 141 876 3972
✉ orders@powerhousefitness.co.uk

Hotline for Technical Information

DE ☎ +49 4621 4210-0
☎ +49 4621 4210-699
✉ service@sport-tiedje.de

NL ☎ +31 172 619961
✉ info@fitshop.nl

UK ☎ +44 141 876 3986
✉ support@powerhousefitness.co.uk

www.sport-tiedje.com
www.taurus-fitness.de

DISCLAIMER



©2011 TAURUS is a registered brand of the company Sport-Tiedje GmbH. All rights reserved. Any use of this trademark without the explicit written permission of Sport-Tiedje is prohibited.

Product and manual are subject to change. Technical data can be changed without advance notice.

Please find a detailed overview including address and opening hours for all specialist fitness stores of the Sport-Tiedje Group in Germany and abroad on the following website.

www.sport-tiedje.com/en/stores

9 EXERCISE MANUAL

The choices you make about the frequency (how often), the duration (how long), and intensity (how hard) at which you will workout, will directly influence your results.

Before beginning any workouts on the Ultra Force exerciser, you should first determine your current fitness level. The following are guidelines that you can use to determine your fitness level, but remember these are just guidelines. You must always listen to your body. Start out at a level that is comfortable to you and progress sensibly.

Beginner - No previous exercise experience, or have not exercised in a long time.

Intermediate - Have been performing exercises regularly for three months or more.

Advanced - Have been performing exercises regularly for six months or more.

LEGS

1. Squat
2. Single Leg Squat
3. Reverse Lunge
4. Seated Leg Extension
5. Seated Single Leg Extension
6. Straight Leg Dead Lift
7. Straight Bar Dead Lift
8. Leg Curls
9. Calf Raises
10. Eversion Calf Raises
11. Inversion Calf Raises
12. Single Leg Kick Back
13. Standing Leg Press
14. Standing Hip Flexion
15. Standing Hip Extension
16. Standing Hip Abduction
17. Standing Hip Adduction
18. Lying Hip Extension
19. Lying Hip Abduction/Adduction
20. Lying Single Leg Abduction/Adduction
21. Lying Double Leg Press
22. Lying Single Leg Press
23. Scissor Kicks
24. Flutter Kicks
25. Lying Hip Rotation
26. Single Leg Lying Hip Rotation
27. Seated Single Leg Press
28. Seated Single Leg Abduction
29. Seated Single Leg Adduction
30. Seated Ankle Eversion
31. Seated Ankle Inversion

CHEST & BACK

32. Seated Chest Press
33. Single Arm Seated Chest Press
34. Incline Chest Press
35. Single Arm Incline Chest Press
36. Chest Fly
37. Single Arm Chest Fly
38. Incline Chest Fly
39. Single Arm Incline Chest Fly
40. Decline Chest Press
41. Closed Grip Chest Press
42. Lat Bar Pull Down
43. Lat Bar Front Pull Down
44. Single Arm Overhand Pull Down
45. Reverse Grip Pull Down
46. Single Arm Reverse Grip Pull Down
47. Neutral Grip Pull Down
48. Single Arm Neutral Grip Pull Down
49. Seated Pull Over
50. Single Arm Seated Pull Over
51. Straight Arm Lateral Pull Down
52. Single Straight Arm Lateral Pull Down
53. Standing Row - Neutral Position
54. Single Arm Standing Row - Neutral Position
55. Standing Row - Overhand Position
56. Single Arm Standing Row - Overhand Position
57. Standing Row - Underhand Position
58. Single Arm Standing Row - Underhand Position
59. Standing Straight Arm Pull Down

SHOULDERS

60. Seated Shoulder Press
61. Single Arm Shoulder Press
62. Shoulder Shrugs
63. Upright Row
64. Standing Front Raise
65. Single Arm Standing Front Raise
66. Standing Lateral Raise
67. Single Arm Standing Lateral Raise
68. Standing Rear Deltoid Rows
69. Single Arm Standing Rear Deltoid Rows
70. Rear Cable Crossover
71. Seated Front Raise

72. Single Arm Seated Front Raise
73. Seated Lateral Raise
74. Single Arm Seated Lateral Raise
75. Rotator Cuff - Low External Rotation
76. Rotator Cuff - Internal Rotation
77. Rotator Cuff - High External Rotation
78. Straight Arm Pull-Back
79. Rotator Cuff - Diagonal External Rotation
80. Rotator Cuff - Diagonal Internal Rotation

ARMS

81. Standing Biceps Curl
82. Single Arm Standing Biceps Curl
83. Standing Hammer Curl
84. Single Arm Standing Hammer Curl
85. Standing Reverse Curl
86. Single Arm Standing Reverse Curl
87. Curved Bar Biceps Curl
88. Curved Bar Reverse Biceps Curl
89. Seated Concentration Curl
90. Seated Wrist Curl
91. Seated Reverse Wrist Curl
92. Seated Overhead Triceps Extension
93. Single Arm Overhead Triceps Extension
94. Standing Triceps Pushdown
95. Reverse Grip Triceps Pushdown
96. Split Grip Triceps Pushdown
97. Single Arm Triceps Pushdown
98. Single Arm Reverse Grip Triceps Pushdown
99. Single Arm Triceps Kickback
100. Single Arm Reverse Grip Triceps Kickback
101. Two Arm Triceps Kickback
102. Two Arm Reverse Grip Triceps Kickback
103. Triceps Dips
104. Single Arm Triceps Dips
105. Cross-Body Triceps Extension

ABS & LOWER BACK

106. Ab Crunch
107. Oblique Crunch
108. Standing Trunk Rotation
109. Side Bend
110. Seated Spinal Extension



MUSCLE GROUPS EXERCISED: Gluteals, hamstrings, quadriceps

LEVEL OF DIFFICULTY: Beginner

1 SQUAT

START: Stand facing frame. Feet hip width apart on base. Grip handles at shoulders.

MOTION: Flex knees, hips and ankles. Lower until thighs are parallel to floor or slightly higher. Press up to starting position.

TIPS: Keep knees in line with toes. Center weight over arches, not toes or heels. Lift chest and keep back straight as hips lower. Keep head lifted and in line with spine. Contract abdominals to stabilize back.

SEAT: Off

LEG LIFT: Off

ACCESSORIES:
Handles

MOVABLE PULLEY POSITIONS

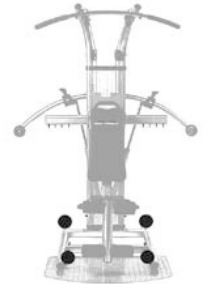

MUSCLE GROUPS EXERCISED: Gluteals, hamstrings, quadriceps

LEVEL OF DIFFICULTY: Intermediate/Advanced

2 SINGLE LEG SQUAT

START: Stand facing frame. Split-leg stance with back heel lifted. Grip handles at shoulders.

MOTION: Flex knees, hips and ankles. Lower until front thigh is parallel to floor or slightly higher. Press up to starting position.

TIPS: Keep weight on front leg and front knee in line with toes. Align shoulders over hips. Lift chest and keep back straight while lowering. Contract abdominals to stabilize back. Perform on both sides.

SEAT: Off

LEG LIFT: Off

ACCESSORIES:
Handles

MOVABLE PULLEY POSITIONS



MUSCLE GROUPS EXERCISED: Gluteals, hamstrings, quadriceps

LEVEL OF DIFFICULTY: Intermediate/Advanced

3 REVERSE LUNGE

START: Stand facing frame. Feet hip width apart on base. Grip handles in front of shoulders.

MOTION: Step back with one leg into lunge position. Lower until front thigh is parallel to floor or slightly higher. Press back up to starting position.

TIPS: Keep weight on front leg and front knee in line with toes. Lift chest and keep back straight while lowering. Contract abdominals to stabilize back. Perform on both sides.

SEAT: Off

LEG LIFT: Off

ACCESSORIES:
Handles

MOVABLE PULLEY POSITIONS





MUSCLE GROUPS EXERCISED: Quadriceps

LEVEL OF DIFFICULTY: Beginner

4 SEATED LEG EXTENSION

START: Sit facing away. Knees over top leg pads. Ankles under bottom leg bar pads. Grip handles next to seat.

MOTION: Extend knees until legs are straight. Pause at top of movement. Lower to starting position.

TIPS: Sit up straight with abdominals contracted. Do not lean back against seat. Keep knee caps aligned with movement point of bar.

SEAT: On/Top Position

LEG LIFT: On

ACCESSORIES: None

MOVABLE PULLEY POSITIONS



MUSCLE GROUPS EXERCISED: Quadriceps

LEVEL OF DIFFICULTY: Intermediate/Advanced

5 SEATED SINGLE LEG EXTENSION

START: Sit facing away. Knees over top leg bar pads. Ankles under bottom leg bar pads. Grip handles next to seat.

MOTION: Extend one knee until leg is straight. Pause at top of movement. Lower to starting position.

TIPS: Sit up straight with abdominals contracted. Do not lean back against seat. Keep knee caps aligned with movement point of bar. Perform on both sides.

SEAT: On/Top Position

LEG LIFT: On

ACCESSORIES: None

MOVABLE PULLEY POSITIONS

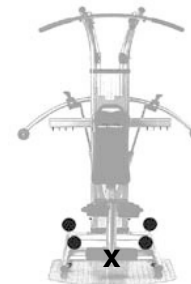

MUSCLE GROUPS EXERCISED: Hamstrings, lumbar spinal extensors

LEVEL OF DIFFICULTY: Intermediate/Advanced

6 STRAIGHT LEG DEAD LIFT

START: Stand facing away. Feet hip width apart on base. Bend at hips and grip handles between legs.

MOTION: Extend hips and back. Stand upright, pulling handles up to front of pelvis. Bend at hips and lower to starting position.

TIPS: Keep arms and legs straight. Hinge up and down from hips. Do not round lower back or bend knees. Contract abdominals to stabilize back. Bend forward until chest is parallel to floor or slightly higher and a slight stretch is felt in hamstrings.

SEAT: Off

LEG LIFT: Off

ACCESSORIES: Handles

MOVABLE PULLEY POSITIONS





MUSCLE GROUPS EXERCISED: Hamstrings, lumbar spinal extensors, gluteals

LEVEL OF DIFFICULTY: Intermediate/Advanced

7 STRAIGHT BAR DEAD LIFT

START: Stand facing frame. Feet hip width apart on base with knees bent. Bend forward at hips and grip lat bar in front of shins.

MOTION: Extend hips and back. Stand upright, pulling bar to front thighs. Bend knees and hips and lower to starting position.

TIPS: Keep arms and back straight with chest and head lifted. Hinge up and down from hips. Do not round lower back. Contract abdominals to stabilize back. Bend forward until a slight stretch is felt in hamstrings.

SEAT: Off

LEG LIFT: Off

ACCESSORIES: Lat Bar/Front Position

MOVABLE PULLEY POSITIONS



MUSCLE GROUPS EXERCISED: Hamstrings

LEVEL OF DIFFICULTY: Beginner

8 LEG CURLS

START: Stand facing frame. One thigh against top leg bar pad. Same side ankle under bottom leg pad. Grip handle at top of seat with same side arm.

MOTION: Flex knee until lower pad is near buttocks. Pause at top of movement. Lower to starting position.

TIPS: Lean slightly forward with entire body. Keep back straight while curling leg. Contract abdominals to stabilize back. Do not lift thigh away from upper leg bar pad. Perform on both sides.

SEAT: On/Top Position

LEG LIFT: On

ACCESSORIES: None

MOVABLE PULLEY POSITIONS



MUSCLE GROUPS EXERCISED: Gastrocnemius, soleus

LEVEL OF DIFFICULTY: Beginner

9 CALF RAISES

START: Stand facing frame. Feet hip width apart on base. Toes facing forward. Grip handles at sides of body.

MOTION: Raise heels, bending at balls of feet. Pause at top of movement. Lower heels to starting position.

TIPS: Keep arms and legs straight. Contract abdominals to stabilize back. Maintain upright position of torso. Do not lean or bend forward or back.

SEAT: Off

LEG LIFT: Off

ACCESSORIES: Handles

MOVABLE PULLEY POSITIONS





MUSCLE GROUPS EXERCISED: Gastrocnemius, soleus

LEVEL OF DIFFICULTY: Intermediate/Advanced

10 EVERSION CALF RAISES

START: Stand facing frame. Feet hip width apart on base. Toes facing outward. Grip handles at sides of body.

MOTION: Raise heels, bending at balls of feet. Pause at top of movement. Lower heels to starting position.

TIPS: Keep arms and legs straight. Contract abdominals to stabilize back. Maintain upright position of torso. Do not lean or bend forward or back.

SEAT: Off

LEG LIFT: Off

ACCESSORIES:
Handles

MOVABLE PULLEY POSITIONS



MUSCLE GROUPS EXERCISED: Gastrocnemius, soleus

LEVEL OF DIFFICULTY: Intermediate/Advanced

11 INVERSION CALF RAISES

START: Stand facing frame. Feet hip width apart on base. Toes facing inward. Grip handles at sides of body.

MOTION: Raise heels, bending at balls of feet. Pause at top of movement. Lower heels to starting position.

TIPS: Keep arms and legs straight. Contract abdominals to stabilize back. Maintain upright position of torso. Do not lean or bend forward or back.

SEAT: Off

LEG LIFT: Off

ACCESSORIES:
Handles

MOVABLE PULLEY POSITIONS



MUSCLE GROUPS EXERCISED: Gluteals, hamstrings

LEVEL OF DIFFICULTY: Beginner

12 SINGLE LEG KICK BACK

START: Stand facing frame. Foot harness/cuff on one ankle, other foot on base. Lean forward from hips. Grip handle at top of seat with both hands.

MOTION: Extend hip. Pull leg straight back behind body. Pause at end of motion. Lower to starting position.

TIPS: Keep leg straight while lifting. Maintain forward lean with straight back. Keep arms straight to stabilize torso. Contract abdominals to stabilize back. Perform on both sides.

SEAT: Off

LEG LIFT: Off

ACCESSORIES:
Foot harness/
Ankle cuff

MOVABLE PULLEY POSITIONS





MUSCLE GROUPS EXERCISED: Gluteals, hamstrings, quadriceps

LEVEL OF DIFFICULTY: Beginner



13 STANDING LEG PRESS

START: Stand facing frame. Foot harness/cuff on one ankle, other foot on base. Grip handle at top of seat with both hands. Bend hip and knee of working leg.

MOTION: Extend hip and knee. Press leg straight back behind body. Pause at end of motion. Flex hip and knee back to starting position.

TIPS: Keep arms straight to stabilize torso. Maintain forward lean with straight back. Contract abdominals to stabilize back. Perform on both sides.

SEAT: Off

LEG LIFT: Off

ACCESSORIES:
Foot harness/
Ankle cuff

MOVABLE PULLEY POSITIONS

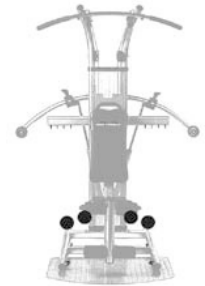

MUSCLE GROUPS EXERCISED: Hip flexors

LEVEL OF DIFFICULTY: Advanced



14 STANDING HIP FLEXION

START: Stand facing away. Foot harness/cuff on one ankle, other foot on base. Place hands on hips.

MOTION: Flex hip and raise leg until thigh is parallel to floor. Pause at top of motion. Lower to starting position.

TIPS: Maintain upright body position. Do not lean forward or back as leg lifts. Contract abdominals to stabilize back. Perform on both sides.

SEAT: Off

LEG LIFT: Off

ACCESSORIES:
Foot harness/
Ankle cuff

MOVABLE PULLEY POSITIONS

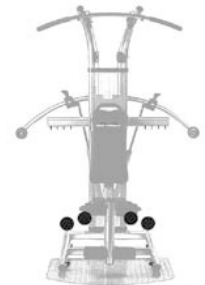

MUSCLE GROUPS EXERCISED: Gluteals, hamstrings

LEVEL OF DIFFICULTY: Beginner



15 STANDING HIP EXTENSION

START: Stand facing frame. Foot harness/cuff on one ankle, other foot on base. Grip handle at top of seat. Bend knee 90 degrees in front of body.

MOTION: Extend hip. Pull thigh in line with or slightly behind standing leg. Pause at end of motion. Return to starting position.

TIPS: Keep knee bent while extending hip. Maintain forward lean with straight back. Keep arms straight to stabilize torso. Contract abdominals to stabilize back. Perform on both sides.

SEAT: Off

LEG LIFT: Off

ACCESSORIES:
Foot harness/
Ankle cuff

MOVABLE PULLEY POSITIONS

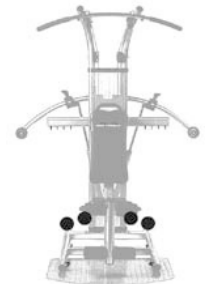



MUSCLE GROUPS EXERCISED: Hip abductors

LEVEL OF DIFFICULTY: Beginner



16 STANDING HIP ABDUCTION

START: Stand facing side. Foot harness/cuff on outside ankle, inside foot on base. Grip handle at top of seat.

MOTION: Lift leg to side, toes facing front. Pause at end of motion. Lower to starting position.

TIPS: Keep leg straight while lifting. Lift leg directly to side. Avoid angling leg front or back, or lifting toes. Maintain upright body position. Do not tip body as leg lifts. Contract abdominals to stabilize back. Perform on both sides.

SEAT: Off

LEG LIFT: Off

ACCESSORIES:
Foot harness/
Ankle cuff

MOVABLE PULLEY POSITIONS



MUSCLE GROUPS EXERCISED: Hip adductors

LEVEL OF DIFFICULTY: Beginner



17 STANDING HIP ADDUCTION

START: Stand facing side. Foot harness/cuff on inside ankle, outside foot on base. Grip handle at top of seat.

MOTION: Pull inside leg across supporting leg, toes facing front. Pause at end of motion. Return to starting position.

TIPS: Pull working leg in front of supporting leg. Maintain upright body position. Do not tip body as leg pulls across. Contract abdominals to stabilize back. Perform on both sides.

SEAT: Off

LEG LIFT: Off

ACCESSORIES:
Foot harness/
Ankle cuff

MOVABLE PULLEY POSITIONS



MUSCLE GROUPS EXERCISED: Gluteals, hamstrings

LEVEL OF DIFFICULTY: Beginner



18 LYING HIP EXTENSION

START: Lie on back facing away, shoulders on base. Foot harnesses/cuffs on ankles. Grip base of frame. Lift one leg perpendicular to floor.

MOTION: Lower leg straight down to floor. Pause at end of motion. Slowly raise to starting position.

TIPS: Keep leg straight while lifting and lowering. Do not allow leg to open to the side. Keep knee in line with shoulder throughout exercise. Do not excessively arch back off floor. Contract abdominals to stabilize back. Perform on both sides.

SEAT: Off

LEG LIFT: Off

ACCESSORIES:
Foot harness/
Ankle cuff

MOVABLE PULLEY POSITIONS



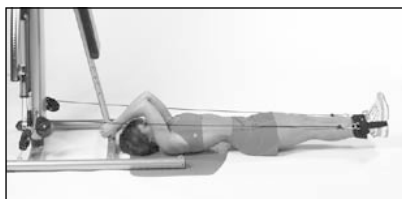

MUSCLE GROUPS EXERCISED: Hip adductors, hip flexors, abdominals

LEVEL OF DIFFICULTY: Intermediate/Advanced

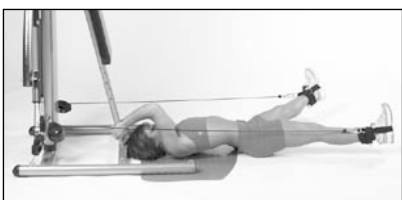

MUSCLE GROUPS EXERCISED: Hip adductors, hip flexors, abdominals

LEVEL OF DIFFICULTY: Advanced



MUSCLE GROUPS EXERCISED: Gluteals, quadriceps, hamstrings, abdominals

LEVEL OF DIFFICULTY: Intermediate/Advanced

19 LYING HIP ABDUCTION/ ADDUCTION

START: Lie on back facing away, shoulders on base. Foot harnesses/cuffs on ankles. Grip base of frame. Lift legs 6 inches off floor.

MOTION: Open both legs to the side. Pause at end of motion. Close legs back to starting position.

TIPS: Keep both legs straight and lifted off floor while opening and closing. Do not excessively arch back off floor. Contract abdominals to stabilize back. Modify by lowering one leg to floor and performing on one side.

SEAT: Off

LEG LIFT: Off

ACCESSORIES: Foot harness/ Ankle cuff

MOVABLE PULLEY POSITIONS



20 LYING SINGLE LEG ABDUCTION/ ADDUCTION

START: Lie on back facing away, shoulders on base. Foot harnesses/cuffs on ankles. Grip base of frame. Lift legs 6 inches off floor.

MOTION: Open one leg to the side. Pause at end of motion. Close leg back to starting position.

TIPS: Keep non-moving leg straight and lifted off floor while opening and closing other leg. Do not excessively arch back off floor. Contract abdominals to stabilize back. Modify by lowering non-moving leg to floor. Perform on both sides.

SEAT: Off

LEG LIFT: Off

ACCESSORIES: Foot harness/ Ankle cuff

MOVABLE PULLEY POSITIONS



21 LYING DOUBLE LEG PRESS

START: Lie on back facing away, shoulders on base. Foot harnesses/cuffs on ankles. Grip base of frame. Bend hips and knees.

MOTION: Extend hips and knees until legs are straight. Pause at end of motion. Return to starting position.

TIPS: Keep knees in line with shoulders throughout exercise. Do not excessively arch back off floor as legs extend. Contract abdominals to stabilize back.

SEAT: Off

LEG LIFT: Off

ACCESSORIES: Foot harness/ Ankle cuff

MOVABLE PULLEY POSITIONS





MUSCLE GROUPS EXERCISED: Gluteals, quadriceps, hamstrings, abdominals

LEVEL OF DIFFICULTY: Beginner



MUSCLE GROUPS EXERCISED: Gluteals, hamstrings

LEVEL OF DIFFICULTY: Beginner



MUSCLE GROUPS EXERCISED: Gluteals, hamstrings, abdominals

LEVEL OF DIFFICULTY: Intermediate

22 LYING SINGLE LEG PRESS

START: Lie on back facing away, shoulders on base. Foot harnesses/cuffs on ankles. Grip base of frame. Bend hip and knee of one leg.

MOTION: Extend hip and knee until leg is straight. Pause at end of motion. Return to starting position.

TIPS: Keep knee in line with shoulder throughout exercise. Do not excessively arch back off floor as leg extends. Contract abdominals to stabilize back. Perform on both sides.

SEAT: Off

LEG LIFT: Off

ACCESSORIES: Foot harness/
Ankle cuff

MOVABLE PULLEY POSITIONS

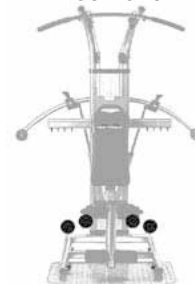

23 SCISSOR KICKS

START: Lie on back facing away, shoulders on base. Foot harnesses/cuffs on ankles. Grip base of frame. Lift one leg perpendicular to floor.

MOTION: Lower leg straight down to floor. Simultaneously lift other leg. Continue alternating legs in "scissor" motion.

TIPS: Keep legs straight while lifting and lowering. Do not allow legs to open to the side. Keep knees in line with shoulders throughout exercise. Do not excessively arch back off floor. Contract abdominals to stabilize back.

SEAT: Off

LEG LIFT: Off

ACCESSORIES: Foot harness/
Ankle cuff

MOVABLE PULLEY POSITIONS



24 FLUTTER KICKS

START: Lie on back facing away, shoulders on base. Foot harnesses/cuffs on ankles. Grip base of frame. Lift one leg 12 inches off floor.

MOTION: Lower leg straight down to floor. Simultaneously lift other leg 12 inches off floor. Continue alternating legs in small "flutter" motion.

TIPS: Keep legs straight while lifting and lowering. Do not allow legs to open to the side. Keep knees in line with shoulders throughout exercise. Do not excessively arch back off floor. Contract abdominals to stabilize back.

SEAT: Off

LEG LIFT: Off

ACCESSORIES: Foot harness/
Ankle cuff

MOVABLE PULLEY POSITIONS

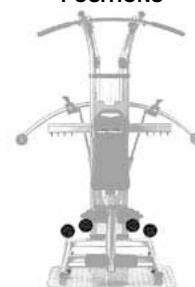



25 LYING HIP ROTATION

START: Lie on back facing away, shoulders on base. Foot harnesses/cuffs on ankles. Grip base of frame. Lift legs 6 inches off floor.

MOTION: Open both legs to the side. Continue in upward circular motion until legs are over hips. Lower to starting position. Reverse direction of motion.

TIPS: Keep legs straight while moving in circular pattern. Do not excessively arch back off floor. Contract abdominals to stabilize back. Perform in both directions.

SEAT: Off

LEG LIFT: Off

ACCESSORIES: Foot harness/ Ankle cuff

MOVABLE PULLEY POSITIONS



MUSCLE GROUPS EXERCISED:

Gluteals, hamstrings, hip adductors, hip flexors, abdominals

LEVEL OF DIFFICULTY:

Intermediate/ Advanced



26 SINGLE LEG LYING HIP ROTATION

START: Lie on back facing away, shoulders on base. Foot harnesses/cuffs on ankles. Grip base of frame. Lift legs 6 inches off floor.

MOTION: Open one leg to the side. Continue in upward circular motion until leg is over hip. Lower to starting position. Reverse direction of motion.

TIPS: Keep leg straight while moving in circular pattern. Do not excessively arch back off floor. Contract abdominals to stabilize back. Perform in both directions. Perform on both sides.

SEAT: Off

LEG LIFT: Off

ACCESSORIES: Foot harness/ Ankle cuff

MOVABLE PULLEY POSITIONS



MUSCLE GROUPS EXERCISED:

Gluteals, hamstrings, hip adductors, hip flexors, abdominals

LEVEL OF DIFFICULTY:

Advanced

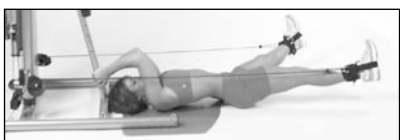

27 SEATED SINGLE LEG PRESS

START: Sit facing away. Foot harness/cuff on one ankle, other foot on floor. Bend knee and lift foot to seat height. Grip handles next to seat.

MOTION: Extend knee until leg is straight and parallel to floor. Pause at end of movement. Bend knee to starting position.

TIPS: Sit up straight with abdominals contracted. Keep knees and toes pointing upward. Press leg forward. Do not allow leg to open to the side. Perform on both sides.

SEAT: On/Bottom Position

LEG LIFT: Off

ACCESSORIES: Foot harness/ Ankle cuff

MOVABLE PULLEY POSITIONS



MUSCLE GROUPS EXERCISED: Gluteals, quadriceps, hamstrings

LEVEL OF DIFFICULTY: Beginner



MUSCLE GROUPS EXERCISED: Hip abductors

LEVEL OF DIFFICULTY: Intermediate/Advanced



28 SEATED SINGLE LEG ABDUCTION

START: Sit facing side. Foot harness/cuff on outside ankle, other foot on floor. Lift leg parallel to floor. Grip top of seat.

MOTION: Open leg to the side, toes facing up. Pause at end of motion. Return to starting position.

TIPS: Sit up straight with abdominals contracted. Do not bend lower back. Keep knees and toes pointing upward as leg abducts. Perform on both sides.

SEAT: On/Bottom Position

LEG LIFT: Off

ACCESSORIES: Foot harness/Ankle cuff

MOVABLE PULLEY POSITIONS



MUSCLE GROUPS EXERCISED: Hip adductors

LEVEL OF DIFFICULTY: Intermediate/Advanced



29 SEATED SINGLE LEG ADDUCTION

START: Sit facing away. Foot harness/cuff on one ankle, other foot on floor. Grip handles next to seat. Open leg to the side, parallel with floor.

MOTION: Pull leg into midline of body. Pause at end of motion. Open leg to starting position.

TIPS: Sit up straight with abdominals contracted. Do not bend lower back. Keep knees and toes pointing upward as leg adducts. Perform on both sides.

SEAT: On/Bottom Position

LEG LIFT: Off

ACCESSORIES: Foot harness/Ankle cuff

MOVABLE PULLEY POSITIONS



MUSCLE GROUPS EXERCISED: Ankle everters

LEVEL OF DIFFICULTY: Beginner



30 SEATED ANKLE EVERSION

START: Sit facing side. Foot harness/cuff on outside ankle, other foot on floor. Grip edge of seat. Lift leg off floor and rotate ankle so toes face inward.

MOTION: Rotate ankle until toes face outward. Pause at end of motion. Rotate ankle back to starting position.

TIPS: Sit up straight with abdominals contracted. Do not bend lower back. Keep rotating foot about 6 inches off floor. Perform on both sides.

SEAT: On/Top Position

LEG LIFT: On

ACCESSORIES: Foot harness/Ankle cuff

MOVABLE PULLEY POSITIONS

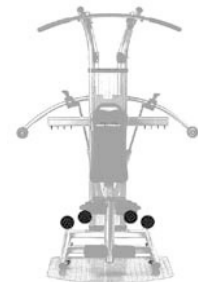



MUSCLE GROUPS EXERCISED: Ankle inverters

LEVEL OF DIFFICULTY: Beginner

31 SEATED ANKLE INVERSION

START: Sit facing side. Foot harness/cuff on inside ankle, other foot on floor. Grip edge of seat. Lift leg off floor and rotate ankle so toes face outward.

MOTION: Rotate ankle until toes face inward. Pause at end of motion. Rotate ankle back to starting position.

TIPS: Sit up straight with abdominals contracted. Do not bend lower back. Keep rotating foot about 6 inches off floor. Perform on both sides

SEAT: On/Top Position

LEG LIFT: On

ACCESSORIES: Foot harness/Ankle cuff

MOVABLE PULLEY POSITIONS

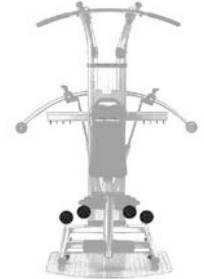



MUSCLE GROUPS EXERCISED: Pectoralis, triceps, anterior deltoids

LEVEL OF DIFFICULTY: Beginner

32 SEATED CHEST PRESS

START: Sit facing away. Grip handles with palms down. Elbows bent 90 degrees at shoulder level. Cables under arms.

MOTION: Extend elbows and press arms straight forward. Pause at end of motion. Bend elbows back to starting position.

TIPS: Press arms forward in arcing motion. Keep elbows in line with shoulders and wrists straight. Maintain upright posture in seated position. Contract abdominals to stabilize back.

SEAT: On/Top Position

LEG LIFT: On

ACCESSORIES: Handles

MOVABLE PULLEY POSITIONS

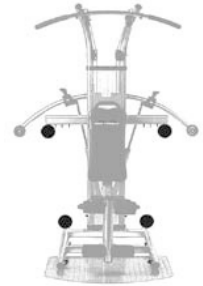

MUSCLE GROUPS EXERCISED: Pectoralis, triceps, anterior deltoids

LEVEL OF DIFFICULTY: Intermediate/Advanced

33 SINGLE ARM SEATED CHEST PRESS

START: Sit facing away. Grip one handle with palm down. Elbow bent 90 degrees at shoulder level. Cable under arm.

MOTION: Extend elbow and press arm straight forward. Pause at end of motion. Bend elbow back to starting position.

TIPS: Press arm forward in arcing motion. Keep elbow in line with shoulder and wrist straight. Avoid rotating torso while pressing. Maintain upright posture in seated position. Contract abdominals to stabilize back. Perform on both sides.

SEAT: On/Top Position

LEG LIFT: On

ACCESSORIES: Handles

MOVABLE PULLEY POSITIONS



MUSCLE GROUPS EXERCISED: Pectoralis, triceps, anterior deltoids

LEVEL OF DIFFICULTY: Intermediate

34 INCLINE CHEST PRESS

START: Sit facing away. Grip handles with palms down. Elbows bent 90 degrees at shoulder level. Cables over arms.

MOTION: Extend elbows and press arms to upward angle. Pause at end of motion. Bend elbows back to starting position.

TIPS: Press arms forward and upward in arcing motion. Handles to head height at end of motion. Keep wrists straight. Maintain upright posture in seated position. Contract abdominals to stabilize back.

SEAT: On/Top Position

LEG LIFT: On

ACCESSORIES: Handles

MOVABLE PULLEY POSITIONS





MUSCLE GROUPS EXERCISED: Pectoralis, triceps, anterior deltoids

LEVEL OF DIFFICULTY: Intermediate/Advanced

35 SINGLE ARM INCLINE CHEST PRESS

START: Sit facing away. Grip one handle with palm down. Elbow bent 90 degrees at shoulder level. Cable over arm.

MOTION: Extend elbow and press arm to upward angle. Pause at end of motion. Bend elbow back to starting position.

TIPS: Press arm forward and upward in arcing motion. Handle to head height at end of motion. Avoid rotating torso while pressing. Maintain upright posture in seated position. Contract abdominals to stabilize back. Perform on both sides.

SEAT: On/Top Position

LEG LIFT: On

ACCESSORIES: Handles

MOVABLE PULLEY POSITIONS



MUSCLE GROUPS EXERCISED: Pectoralis, anterior deltoids

LEVEL OF DIFFICULTY: Beginner

36 CHEST FLY

START: Sit facing away. Grip handles with arms open to sides. Palms facing front.

MOTION: Close arms in front of chest. Pause at end of motion. Open arms to starting position.

TIPS: Keep arms almost straight throughout exercise. Do not bend elbows at end of motion. Elbows and wrists in line with shoulders. Maintain upright posture in seated position. Contract abdominals to stabilize back.

SEAT: On/Top Position

LEG LIFT: On

ACCESSORIES: Handles

MOVABLE PULLEY POSITIONS



MUSCLE GROUPS EXERCISED: Pectoralis, anterior deltoids

LEVEL OF DIFFICULTY: Intermediate/Advanced

37 SINGLE ARM CHEST FLY

START: Sit facing away. Grip one handle with arm open to side. Palm facing front.

MOTION: Close arm in front of chest. Handle to midline of chest. Pause at end of motion. Open arm to starting position.

TIPS: Keep arm almost straight throughout exercise. Do not bend elbow at end of motion. Avoid rotating torso while pressing. Maintain upright posture in seated position. Contract abdominals to stabilize back. Perform on both sides.

SEAT: On/Top Position

LEG LIFT: On

ACCESSORIES: Handles

MOVABLE PULLEY POSITIONS





MUSCLE GROUPS EXERCISED: Pectoralis, anterior deltoids

LEVEL OF DIFFICULTY: Intermediate

38 INCLINE CHEST FLY

START: Sit facing away. Grip handles with arms open to sides. Palms facing front.

MOTION: Close and angle arms upward to head height. Pause at end of motion. Open and lower arms to starting position.

TIPS: Keep arms almost straight throughout exercise. Do not bend elbows at end of motion. Elbows and wrists in line with shoulders. Maintain upright posture in seated position. Contract abdominals to stabilize back.

SEAT: On/Top Position

LEG LIFT: On

ACCESSORIES: Handles

MOVABLE PULLEY POSITIONS

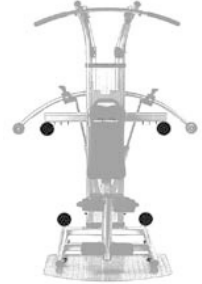

MUSCLE GROUPS EXERCISED: Pectoralis, anterior deltoids

LEVEL OF DIFFICULTY: Intermediate/Advanced

39 SINGLE ARM INCLINE CHEST FLY

START: Sit facing away. Grip one handle with arm open to side. Palm facing front.

MOTION: Close and angle arm upward to head height. Handle to midline of forehead. Pause at end of motion. Open to starting position.

TIPS: Keep arm almost straight throughout exercise. Do not bend elbow at end of motion. Avoid rotating torso while pressing. Maintain upright posture in seated position. Contract abdominals to stabilize back. Perform on both sides.

SEAT: On/Top Position

LEG LIFT: On

ACCESSORIES: Handles

MOVABLE PULLEY POSITIONS



MUSCLE GROUPS EXERCISED: Pectoralis, triceps, anterior deltoids

LEVEL OF DIFFICULTY: Intermediate

40 DECLINE CHEST PRESS

START: Sit facing away with hips forward on seat, shoulders touching backrest. Grip handles with cables under arms. Elbows bent 90 degrees at shoulder level.

MOTION: Extend elbows and press arms forward and downward. Pause at end of motion. Bend elbows back to starting position.

TIPS: Press arms downward to hip level. Keep elbows in line with shoulders and wrists straight. Maintain straight spine position while leaning back. Do not round lower back. Contract abdominals to stabilize back.

SEAT: On/Top Position

LEG LIFT: On

ACCESSORIES: Handles

MOVABLE PULLEY POSITIONS





MUSCLE GROUPS EXERCISED: Pectoralis, triceps, anterior deltoids

LEVEL OF DIFFICULTY: Beginner

41 CLOSED GRIP CHEST PRESS

START: Sit facing away. Grip handles with palms facing in. Elbows bent 90 degrees at waist level. Cables under arms.

MOTION: Extend elbows and press arms straight forward. Pause at end of motion. Bend elbows back to starting position.

TIPS: Press arms forward in arcing motion. Keep elbows in line with shoulders and wrists straight. Maintain upright posture in seated position. Contract abdominals to stabilize back.

SEAT: On/Top Position

LEG LIFT: On

ACCESSORIES: Handles

MOVABLE PULLEY POSITIONS



MUSCLE GROUPS EXERCISED: Latissimus, biceps

LEVEL OF DIFFICULTY: Beginner

42 LAT BAR PULL DOWN

START: Sit facing frame. Grip lat bar toward outside of handles, palms facing forward. Lean back slightly.

MOTION: Bend elbows and pull bar down to chest. Pause at bottom of motion. Extend elbows and raise to starting position.

TIPS: Hold leaning position throughout exercise. Do not move torso forward and back. Maintain straight spine while leaning back. Do not round lower back. Contract abdominals to stabilize torso.

SEAT: On/Top Position

LEG LIFT: On

ACCESSORIES: Lat Bar/Lat Tower Pos.

MOVABLE PULLEY POSITIONS



MUSCLE GROUPS EXERCISED: Latissimus, biceps

LEVEL OF DIFFICULTY: Beginner

43 LAT BAR FRONT PULL DOWN

START: Sit facing away. Feet on base. Grip lat bar toward outside of handles, palms facing forward.

MOTION: Bend elbows and pull bar down to chest. Pause at bottom of motion. Extend elbows and raise to starting position.

TIPS: Maintain upright posture throughout exercise. Do not round lower back. Keep shoulders pulled down away from ears. Contract abdominals to stabilize torso.

SEAT: On/Top Position

LEG LIFT: On

ACCESSORIES: Lat Bar/Lat Tower Pos.

MOVABLE PULLEY POSITIONS





MUSCLE GROUPS EXERCISED: Latissimus, biceps
LEVEL OF DIFFICULTY: Intermediate/Advanced

44 SINGLE ARM OVERHAND PULL DOWN

START: Sit facing frame. Grip one handle with palms facing forward. Lean back slightly.

MOTION: Bend elbow and pull handle down to chest. Pause at bottom of motion. Extend elbow and raise to starting position.

TIPS: Hold leaning position throughout exercise. Do not move torso forward or back. Maintain straight spine while leaning. Do not tip or rotate to one side. Contract abdominals to stabilize torso. Perform on both sides.

SEAT: On/Bottom Position

LEG LIFT: On

ACCESSORIES: Handles/Lat Tower

MOVABLE PULLEY POSITIONS

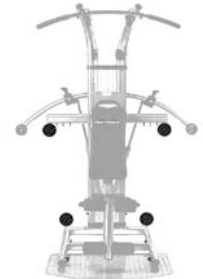

MUSCLE GROUPS EXERCISED: Latissimus, biceps
LEVEL OF DIFFICULTY: Beginner

45 REVERSE GRIP PULL DOWN

START: Sit facing frame. Lean back slightly. Grip handles in underhand position.

MOTION: Bend elbows and pull handles down to chest. Pause at bottom of motion. Extend elbows and raise to starting position.

TIPS: Hold leaning position throughout exercise. Do not move torso forward and back. Maintain straight spine while leaning. Do not round lower back. Contract abdominals to stabilize torso.

SEAT: On/Bottom Position

LEG LIFT: On

ACCESSORIES: Handles/Lat Tower

MOVABLE PULLEY POSITIONS

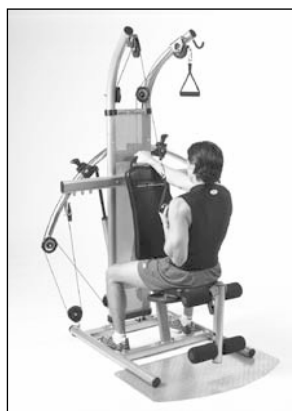

MUSCLE GROUPS EXERCISED: Latissimus, biceps
LEVEL OF DIFFICULTY: Intermediate/Advanced

46 SINGLE ARM REVERSE GRIP PULL DOWN

START: Sit facing frame. Lean back slightly. Grip one handle in underhand position.

MOTION: Bend elbow and pull handle down to chest. Pause at bottom of motion. Extend elbow and raise to starting position.

TIPS: Hold leaning position throughout exercise. Do not move torso forward or back. Maintain straight spine while leaning. Do not tip or rotate to one side. Contract abdominals to stabilize torso. Perform on both sides.

SEAT: On/Bottom Position

LEG LIFT: On

ACCESSORIES: Handles/Lat Tower

MOVABLE PULLEY POSITIONS





MUSCLE GROUPS EXERCISED: Latissimus, biceps
LEVEL OF DIFFICULTY: Beginner

47 NEUTRAL GRIP PULL DOWN

START: Sit facing frame. Lean back slightly. Grip handles in neutral position with palms facing in.

MOTION: Bend elbows and pull handles down to chest. Pause at bottom of motion. Extend elbows and raise to starting position.

TIPS: Hold leaning position throughout exercise. Do not move torso forward and back. Maintain straight spine while leaning. Do not round lower back. Contract abdominals to stabilize torso.

SEAT: On/Bottom Position

LEG LIFT: On

ACCESSORIES: Handles/Lat Tower

MOVABLE PULLEY POSITIONS



MUSCLE GROUPS EXERCISED: Latissimus, biceps
LEVEL OF DIFFICULTY: Intermediate/Advanced

48 SINGLE ARM NEUTRAL GRIP PULL DOWN

START: Sit facing frame. Lean back slightly. Grip one handle in neutral position with palm facing in.

MOTION: Bend elbow and pull handle down to chest. Pause at bottom of motion. Extend elbow and raise to starting position.

TIPS: Hold leaning position throughout exercise. Do not move torso forward or back. Maintain straight spine while leaning. Do not tip or rotate to one side. Contract abdominals to stabilize torso. Perform on both sides.

SEAT: On/Bottom Position

LEG LIFT: On

ACCESSORIES: Handles/Lat Tower

MOVABLE PULLEY POSITIONS



MUSCLE GROUPS EXERCISED: Latissimus, posterior deltoid
LEVEL OF DIFFICULTY: Beginner

49 SEATED PULL OVER

START: Sit facing away. Feet on base. Grip handles with palms facing forward.

MOTION: Pull arms forward and down until handles are at waist level. Pause at end of motion. Raise arms back to starting position.

TIPS: Keep arms straight throughout exercise. Do not bend elbows while pulling down. Maintain upright posture. Do not round lower back. Keep shoulders pulled down away from ears. Contract abdominals to stabilize torso.

SEAT: On/Bottom Position

LEG LIFT: On

ACCESSORIES: Handles/Lat Tower

MOVABLE PULLEY POSITIONS





MUSCLE GROUPS EXERCISED: Latissimus, posterior deltoid
LEVEL OF DIFFICULTY: Intermediate/Advanced

50 SINGLE ARM SEATED PULL OVER

START: Sit facing away. Feet on base. Grip one handle with palm facing forward.

MOTION: Pull arm forward and down until handle is at waist level. Pause at end of motion. Raise arm back to starting position.

TIPS: Keep arm straight throughout exercise. Do not bend elbow while pulling down. Maintain upright posture. Do not tip or rotate torso. Contract abdominals to stabilize torso. Perform on both sides.

SEAT: On/Bottom Position

LEG LIFT: On

ACCESSORIES: Handles/Lat Tower

MOVABLE PULLEY POSITIONS

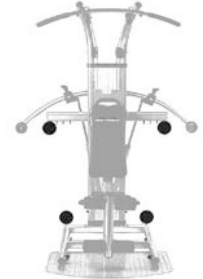

MUSCLE GROUPS EXERCISED: Latissimus
LEVEL OF DIFFICULTY: Beginner

51 STRAIGHT ARM LATERAL PULL DOWN

START: Sit facing away. Feet on base. Grip handles with palms facing outward.

MOTION: Pull arms down laterally until handles are at waist level. Pause at end of motion. Raise arms back to starting position.

TIPS: Keep arms straight throughout exercise. Do not bend elbows while pulling down. Maintain upright posture. Do not round lower back. Keep shoulders pulled down away from ears. Contract abdominals to stabilize torso.

SEAT: On/Bottom Position

LEG LIFT: On

ACCESSORIES: Handles/Lat Tower

MOVABLE PULLEY POSITIONS



MUSCLE GROUPS EXERCISED: Latissimus
LEVEL OF DIFFICULTY: Intermediate/Advanced

52 SINGLE STRAIGHT ARM LATERAL PULL DOWN

START: Sit facing away. Feet on base. Grip one handle with palm facing outward.

MOTION: Pull arm down laterally until handle is at waist level. Pause at end of motion. Raise arm back to starting position.

TIPS: Keep arm straight throughout exercise. Do not bend elbow while pulling down. Maintain upright posture. Do not tip or rotate torso. Contract abdominals to stabilize torso. Perform on both sides.

SEAT: On/Bottom Position

LEG LIFT: On

ACCESSORIES: Handles/Lat Tower

MOVABLE PULLEY POSITIONS





MUSCLE GROUPS EXERCISED: Latissimus, biceps, posterior deltoids

LEVEL OF DIFFICULTY: Beginner

53 STANDING ROW - NEUTRAL POSITION

START: Stand facing frame. Rest legs against pads. Bend knees slightly. Grip handles with thumbs facing up.

MOTION: Bend elbows and pull handles toward waist. Pause at end of motion. Extend elbows and return to starting position.

TIPS: Keep elbows close to sides while pulling. Squeeze shoulder blades together. Maintain upright posture. Do not lean forward or back. Contract abdominals to stabilize back.

SEAT: On/Bottom Position

LEG LIFT: On

ACCESSORIES: Handles

MOVABLE PULLEY POSITIONS



MUSCLE GROUPS EXERCISED: Latissimus, biceps, posterior deltoids

LEVEL OF DIFFICULTY: Intermediate/Advanced

54 SINGLE ARM STANDING ROW - NEUTRAL POSITION

START: Stand facing frame. Rest legs against pads. Bend knees slightly. Grip one handle with thumb facing up.

MOTION: Bend elbow and pull handle toward waist. Pause at end of motion. Extend elbow and return to starting position.

TIPS: Keep elbow close to side while pulling. Maintain upright posture. Do not lean forward or back. Keep shoulders level. Do not rotate side while pulling. Contract abdominals to stabilize back. Perform on both sides.

SEAT: On/Bottom Position

LEG LIFT: On

ACCESSORIES: Handles

MOVABLE PULLEY POSITIONS



MUSCLE GROUPS EXERCISED: Latissimus, biceps, posterior deltoids

LEVEL OF DIFFICULTY: Beginner

55 STANDING ROW - OVERHAND POSITION

START: Stand facing frame. Rest legs against pads. Bend knees slightly. Grip handles with thumbs facing inward.

MOTION: Bend elbows and pull handles toward waist. Pause at end of motion. Extend elbows and return to starting position.

TIPS: Keep elbows close to sides while pulling. Squeeze shoulder blades together. Maintain upright posture. Do not lean forward or back. Contract abdominals to stabilize back.

SEAT: On/Bottom Position

LEG LIFT: On

ACCESSORIES: Handles

MOVABLE PULLEY POSITIONS





MUSCLE GROUPS EXERCISED: Latissimus, biceps, posterior deltoids

LEVEL OF DIFFICULTY: Intermediate/Advanced

56 SINGLE ARM STANDING ROW - OVERHAND POSITION

START: Stand facing frame. Rest legs against pads. Bend knees slightly. Grip one handle with thumb facing inward.

MOTION: Bend elbow and pull handle toward waist. Pause at end of motion. Extend elbow and return to starting position.

TIPS: Keep elbow close to side while pulling. Maintain upright posture. Do not lean forward or back. Keep shoulders level. Do not rotate side while pulling. Contract abdominals to stabilize back. Perform on both sides.

SEAT: On/Bottom Position

LEG LIFT: On

ACCESSORIES: Handles

MOVABLE PULLEY POSITIONS

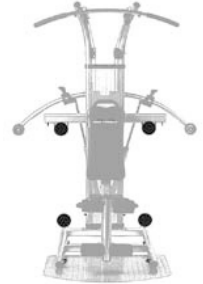

MUSCLE GROUPS EXERCISED: Latissimus, biceps, posterior deltoids

LEVEL OF DIFFICULTY: Beginner

57 STANDING ROW - UNDERHAND POSITION

START: Stand facing frame. Rest legs against pads. Bend knees slightly. Grip handles with thumbs facing outward.

MOTION: Bend elbows and pull handles toward waist. Pause at end of motion. Extend elbows and return to starting position.

TIPS: Keep elbows close to sides while pulling. Squeeze shoulder blades together. Maintain upright posture. Do not lean forward or back. Contract abdominals to stabilize back.

SEAT: On/Bottom Position

LEG LIFT: On

ACCESSORIES: Handles

MOVABLE PULLEY POSITIONS

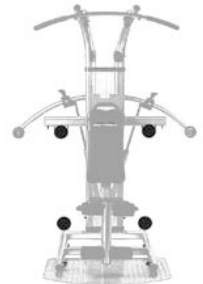

MUSCLE GROUPS EXERCISED: Latissimus, biceps, posterior deltoids

LEVEL OF DIFFICULTY: Intermediate/Advanced

58 SINGLE ARM STANDING ROW - UNDERHAND POSITION

START: Stand facing frame. Rest legs against pads. Bend knees slightly. Grip one handle with thumb facing outward.

MOTION: Bend elbow and pull handle toward waist. Pause at end of motion. Extend elbow and return to starting position.

TIPS: Keep elbow close to side while pulling. Maintain upright posture. Do not lean forward or back. Keep shoulders level. Do not rotate side while pulling. Contract abdominals to stabilize back. Perform on both sides.

SEAT: On/Bottom Position

LEG LIFT: On

ACCESSORIES: Handles

MOVABLE PULLEY POSITIONS





MUSCLE GROUPS EXERCISED: Latissimus, posterior deltoid

LEVEL OF DIFFICULTY: Intermediate

59 STANDING STRAIGHT ARM PULL DOWN

START: Stand facing frame. Feet hip width apart on base. Grip lat bar in wide grip with palms facing down.

MOTION: Pull arms straight down toward hips. Pause at end of motion. Raise arms back to starting position.

TIPS: Keep arms straight throughout exercise. Do not bend elbows while pulling down. Maintain upright posture. Do not lean forward or back. Contract abdominals to stabilize torso.

SEAT: Off

LEG LIFT: Off

ACCESSORIES:
Lat Bar/Lat Tower
Position

MOVABLE PULLEY POSITIONS





MUSCLE GROUPS EXERCISED: Deltoids

LEVEL OF DIFFICULTY: Beginner



60 SEATED SHOULDER PRESS

START: Sit facing away. Grip handles with thumbs facing in. Elbows bent 90 degrees at shoulder level.

MOTION: Extend elbows and press arms overhead. Pause at top of motion. Bend elbows back to starting position.

TIPS: Press arms up in arcing motion until hands almost touch. Keep elbows and wrists in line with shoulders. Do not lower elbows below shoulder line. Maintain straight wrists. Contract abdominals to stabilize torso.

SEAT: On/Top Position

LEG LIFT: On

ACCESSORIES: Handles

MOVABLE PULLEY POSITIONS



MUSCLE GROUPS EXERCISED: Deltoids

LEVEL OF DIFFICULTY: Intermediate/Advanced



61 SINGLE ARM SHOULDER PRESS

START: Sit facing away. Grip one handle with thumb facing in. Elbow bent 90 degrees at shoulder level.

MOTION: Extend elbow and press arm overhead. Pause at top of motion. Bend elbow back to starting position.

TIPS: Press arm up in arcing motion to midline over head. Keep elbow and wrist in line with shoulder. Do not lower elbow below shoulder line. Maintain straight wrist. Contract abdominals to stabilize torso. Perform on both sides.

SEAT: On/Top Position

LEG LIFT: On

ACCESSORIES: Handles

MOVABLE PULLEY POSITIONS



MUSCLE GROUPS EXERCISED: Trapezius

LEVEL OF DIFFICULTY: Beginner



62 SHOULDER SHRUGS

START: Stand facing frame. Feet hip width apart on base. Grip lat bar in front of thighs with thumbs facing in.

MOTION: Shrug shoulders up with straight arms. Pause at top of motion. Lower shoulders to starting position.

TIPS: Maintain upright posture throughout exercise. Contract triceps muscles to stabilize arm. Do not bend elbows while shrugging. Contract abdominals to stabilize torso.

SEAT: Off

LEG LIFT: Off

ACCESSORIES: Lat Bar/Front Position

MOVABLE PULLEY POSITIONS





MUSCLE GROUPS EXERCISED: Trapezius, deltoids

LEVEL OF DIFFICULTY: Intermediate/Advanced

63 UPRIGHT ROW

START: Stand facing frame. Feet hip width apart on base. Grip lat bar in front of thighs with thumbs facing in.

MOTION: Bend elbows and pull bar up to chest level. Pause at top of motion. Lower bar to starting position.

TIPS: Maintain upright posture throughout exercise. Do not lean back while lifting bar. Lift elbows to shoulder height or slightly higher. Keep wrists straight. Contract abdominals to stabilize torso.

SEAT: Off

LEG LIFT: Off

ACCESSORIES: Lat Bar/Front Position

MOVABLE PULLEY POSITIONS

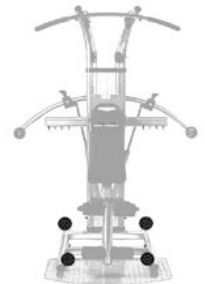

MUSCLE GROUPS EXERCISED: Anterior deltoids

LEVEL OF DIFFICULTY: Beginner

64 STANDING FRONT RAISE

START: Stand facing away. Feet hip width apart on base. Grip handles with arms at sides, thumbs facing in.

MOTION: Raise arms in front of body. Pause at top of motion. Lower arms to starting position.

TIPS: Raise arms to nose level. Keep elbows almost straight. Maintain upright posture throughout exercise. Do not lean or tilt backward. Keep wrists straight while raising arms. Contract abdominals to stabilize torso.

SEAT: Off

LEG LIFT: Off

ACCESSORIES: Handles

MOVABLE PULLEY POSITIONS



MUSCLE GROUPS EXERCISED: Anterior deltoids

LEVEL OF DIFFICULTY: Intermediate/Advanced

65 SINGLE ARM STANDING FRONT RAISE

START: Stand facing away. Feet hip width apart on base. Grip one handle with arm at side, thumb facing in.

MOTION: Raise arm in front of body. Pause at top of motion. Lower arm to starting position.

TIPS: Raise arm to nose level. Keep elbow almost straight. Maintain upright posture throughout exercise. Do not lean or tilt backward. Keep wrist straight while raising arm. Contract abdominals to stabilize torso. Perform on both sides.

SEAT: Off

LEG LIFT: Off

ACCESSORIES: Handles

MOVABLE PULLEY POSITIONS





MUSCLE GROUPS EXERCISED: Medial deltoids

LEVEL OF DIFFICULTY: Beginner

66 STANDING LATERAL RAISE

START: Stand facing away. Feet hip width apart on base. Grip handles with arms at sides, thumbs facing front.

MOTION: Raise arms laterally. Pause at top of motion. Lower arms to starting position.

TIPS: Raise arms to shoulder level or slightly higher. Keep elbows almost straight. Maintain upright posture throughout exercise. Do not lean or tilt backward. Keep wrists straight while raising arms. Contract abdominals to stabilize torso.

SEAT: Off

LEG LIFT: Off

ACCESSORIES:
Handles

MOVABLE PULLEY POSITIONS

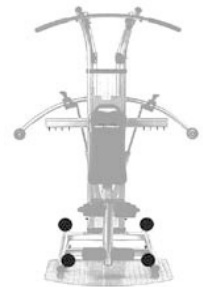

MUSCLE GROUPS EXERCISED: Medial deltoids

LEVEL OF DIFFICULTY: Intermediate/Advanced

67 SINGLE ARM STANDING LATERAL RAISE

START: Stand facing away. Feet hip width apart on base. Grip one handle with arm at side, thumb facing front.

MOTION: Raise arm laterally. Pause at top of motion. Lower arm to starting position.

TIPS: Raise arm to shoulder level or slightly higher. Keep elbow almost straight. Maintain upright posture throughout exercise. Do not lean or tilt backward. Keep wrist straight while raising arm. Contract abdominals to stabilize torso. Perform on both sides.

SEAT: Off

LEG LIFT: Off

ACCESSORIES:
Handles

MOVABLE PULLEY POSITIONS

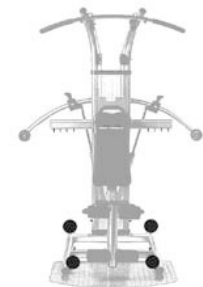

MUSCLE GROUPS EXERCISED: Posterior deltoids

LEVEL OF DIFFICULTY: Beginner

68 STANDING REAR DELTOID ROWS

START: Stand facing frame. Feet hip width apart on base. Grip handles in front of body with palms facing down.

MOTION: Bend elbows and pull up and back. Pause at top of motion. Straighten elbows and return to starting position.

TIPS: Pull elbows slightly behind shoulder line. Keep elbows lifted and bent at a 90 degree angle. Do not lift wrists higher than elbows or shoulders. Contract abdominals to stabilize torso.

SEAT: Off

LEG LIFT: Off

ACCESSORIES:
Handles

MOVABLE PULLEY POSITIONS





MUSCLE GROUPS EXERCISED: Posterior deltoids

LEVEL OF DIFFICULTY: Intermediate/Advanced

69 SINGLE ARM STANDING REAR DELTOID ROWS

START: Stand facing frame. Feet hip width apart on base. Grip one handle in front of body with palm facing down.

MOTION: Bend elbow and pull up and back. Pause at top of motion. Straighten elbow and return to starting position.

TIPS: Pull elbow slightly behind shoulder line. Keep elbow lifted and bent at a 90 degree angle. Do not lift wrist higher than elbow or shoulder. Contract abdominals to stabilize torso. Perform on both sides.

SEAT: Off

LEG LIFT: Off

ACCESSORIES:
Handles

MOVABLE PULLEY POSITIONS

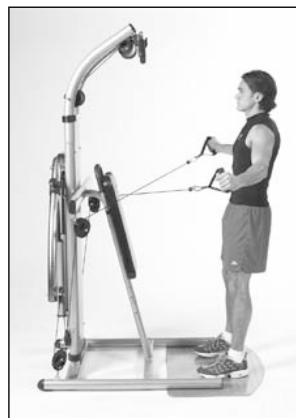
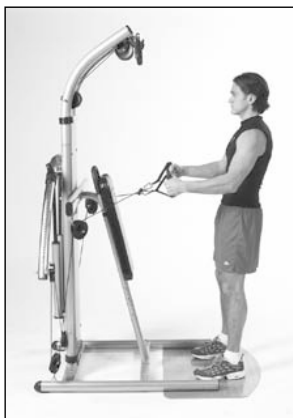

MUSCLE GROUPS EXERCISED: Posterior deltoids

LEVEL OF DIFFICULTY: Beginner

70 REAR CABLE CROSSOVER

START: Stand facing frame. Feet hip width apart on base. Cross cables and grip handles at waist level.

MOTION: Open arms to sides. Pause at end of motion. Close arms and return to starting position.

TIPS: Open arms until elbows are in line with shoulders. Keep arms almost straight throughout motion. Align wrists with elbows. Maintain upright posture throughout exercise. Contract abdominals to stabilize torso.

SEAT: Off

LEG LIFT: Off

ACCESSORIES:
Handles

MOVABLE PULLEY POSITIONS



MUSCLE GROUPS EXERCISED: Anterior deltoids

LEVEL OF DIFFICULTY: Beginner

71 SEATED FRONT RAISE

START: Sit facing away. Grip handles with arms at sides, thumbs facing in.

MOTION: Raise arms in front of body. Pause at top of motion. Lower arms to starting position.

TIPS: Raise arms to shoulder level or slightly higher. Keep elbows almost straight. Do not let wrists bend while lifting. Maintain upright posture in seated position. Contract abdominals to stabilize torso.

SEAT: On/Top Position

LEG LIFT: On

ACCESSORIES:
Handles

MOVABLE PULLEY POSITIONS





MUSCLE GROUPS EXERCISED: Anterior deltoids

LEVEL OF DIFFICULTY: Intermediate/Advanced



72 SINGLE ARM SEATED FRONT RAISE

START: Sit facing away. Grip one handle with arm at side, thumb facing in.

MOTION: Raise arm in front of body. Pause at top of motion. Lower arm to starting position.

TIPS: Raise arm to shoulder level or slightly higher. Keep elbow almost straight. Do not let wrist bend while lifting. Maintain upright posture in seated position. Contract abdominals to stabilize torso. Perform on both sides.

SEAT: On/Top Position

LEG LIFT: On

ACCESSORIES: Handles

MOVABLE PULLEY POSITIONS

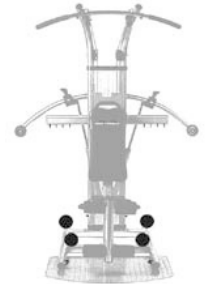

MUSCLE GROUPS EXERCISED: Medial deltoids

LEVEL OF DIFFICULTY: Beginner



73 SEATED LATERAL RAISE

START: Sit facing away. Grip handles with arms at sides, thumbs facing forward.

MOTION: Raise arms laterally. Pause at top of motion. Lower arms to starting position.

TIPS: Raise arms to shoulder level or slightly higher. Keep elbows almost straight. Do not let wrists bend while lifting. Maintain upright posture in seated position. Contract abdominals to stabilize torso.

SEAT: On/Top Position

LEG LIFT: On

ACCESSORIES: Handles

MOVABLE PULLEY POSITIONS

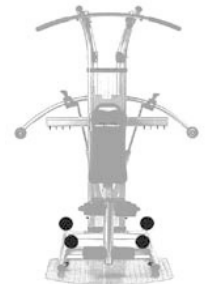

MUSCLE GROUPS EXERCISED: Medial deltoids

LEVEL OF DIFFICULTY: Intermediate/Advanced



74 SINGLE ARM SEATED LATERAL RAISE

START: Sit facing away. Grip one handle with arm at side, thumb facing forward.

MOTION: Raise arm laterally. Pause at top of motion. Lower arm to starting position.

TIPS: Raise arm to shoulder level or slightly higher. Keep elbow almost straight. Do not let wrist bend while lifting. Maintain upright posture in seated position. Contract abdominals to stabilize torso. Perform on both sides.

SEAT: On/Top Position

LEG LIFT: On

ACCESSORIES: Handles

MOVABLE PULLEY POSITIONS

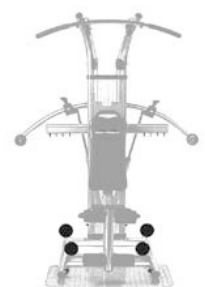



MUSCLE GROUPS EXERCISED: External shoulder rotators

LEVEL OF DIFFICULTY: Beginner

75 ROTATOR CUFF - LOW EXTERNAL ROTATION

START: Stand facing side. Bend outside elbow 90 degrees and grip handle in front of waist. Grip back of seat with inside hand.

MOTION: Externally rotate arm to outside. Pause at end of motion. Return to starting position.

TIPS: Keep elbow against body while rotating shoulder. Avoid lifting upper arm away from torso. Keep shoulders square. Do not rotate torso to one side. Contract abdominals to stabilize torso. Perform on both sides.

SEAT: Off

LEG LIFT: Off

ACCESSORIES:
Handles

MOVABLE PULLEY POSITIONS



MUSCLE GROUPS EXERCISED: Internal shoulder rotators

LEVEL OF DIFFICULTY: Beginner

76 ROTATOR CUFF - INTERNAL ROTATION

START: Stand facing side. Bend inside elbow 90 degrees and grip handle in front of waist. Place outside hand on hip.

MOTION: Internally rotate arm across body. Pause at end of motion. Return to starting position.

TIPS: Keep elbow against body while rotating shoulder. Avoid pulling upper arm across torso. Keep shoulders square. Do not rotate torso to one side. Contract abdominals to stabilize torso. Perform on both sides.

SEAT: Off

LEG LIFT: Off

ACCESSORIES:
Handles

MOVABLE PULLEY POSITIONS



MUSCLE GROUPS EXERCISED: External shoulder rotators

LEVEL OF DIFFICULTY: Intermediate

77 ROTATOR CUFF - HIGH EXTERNAL ROTATION

START: Stand facing frame. Feet hip width apart on base. Bend one elbow 90 degrees at shoulder. Grip handle with palm facing down.

MOTION: Externally rotate shoulder, pulling hand above elbow. Pause at top of motion. Return to starting position.

TIPS: Hold elbow at shoulder height while rotating. Keep wrist straight. Do not pull arm back or rotate torso. Contract abdominals to stabilize torso. Perform on both sides.

SEAT: Off

LEG LIFT: Off

ACCESSORIES:
Handles

MOVABLE PULLEY POSITIONS



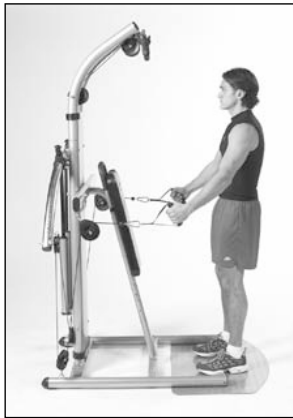

MUSCLE GROUPS EXERCISED: Posterior deltoids, latissimus

LEVEL OF DIFFICULTY: Beginner

78 STRAIGHT ARM PULL-BACK

START: Stand facing frame. Feet hip width apart on base. Grip handles in front of body with thumbs facing up.

MOTION: Pull arms straight back behind body. Pause at end of motion. Return to starting position.

TIPS: Keep elbows straight. Maintain upright posture throughout exercise. Do not lean or tilt forward. Keep wrists straight while pulling back. Contract abdominals to stabilize torso. Perform on both sides.

SEAT: Off

LEG LIFT: Off

ACCESSORIES:
Handles

MOVABLE PULLEY POSITIONS

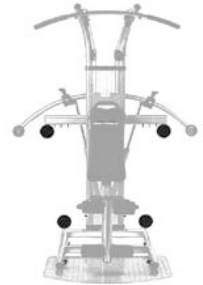

MUSCLE GROUPS EXERCISED: External shoulder rotators

LEVEL OF DIFFICULTY: Intermediate

79 ROTATOR CUFF - DIAGONAL EXTERNAL ROTATION

START: Stand facing side. Grip handle across body with outside arm. Grip back of seat with inside hand.

MOTION: Externally rotate shoulder, pulling arm diagonally across body. Pause at end of motion. Return to starting position.

TIPS: Keep elbow almost straight while opening arm. Do not bend wrist. Keep shoulders square. Do not rotate torso to one side. Contract abdominals to stabilize torso. Perform on both sides.

SEAT: Off

LEG LIFT: Off

ACCESSORIES:
Handles

MOVABLE PULLEY POSITIONS



MUSCLE GROUPS EXERCISED: Internal shoulder rotators

LEVEL OF DIFFICULTY: Intermediate

80 ROTATOR CUFF - DIAGONAL INTERNAL ROTATION

START: Stand facing side. Grip handle in front of body with inside arm. Place outside hand on hip.

MOTION: Internally rotate shoulder, pulling arm diagonally across body. Pause at end of motion. Return to starting position.

TIPS: Keep elbow almost straight while pulling arm across body. Do not bend wrist. Keep shoulders square. Do not rotate torso to one side. Contract abdominals to stabilize torso. Perform on both sides.

SEAT: Off

LEG LIFT: Off

ACCESSORIES:
Handles

MOVABLE PULLEY POSITIONS





MUSCLE GROUPS EXERCISED: Biceps, forearm flexors

LEVEL OF DIFFICULTY: Beginner

81 STANDING BICEPS CURL

START: Stand facing away. Feet hip width apart on base. Grip handles in underhand grip with thumbs facing outward.

MOTION: Bend elbows and curl handles toward front of shoulders. Pause at top of motion. Lower arms to starting position.

TIPS: Hold elbows at sides of ribcage. Do not swing elbows forward while curling. Maintain upright posture throughout exercise. Avoid tilting torso back while curling arms. Contract abdominals to stabilize torso.

SEAT: Off

LEG LIFT: Off

ACCESSORIES:
Handles

MOVABLE PULLEY POSITIONS

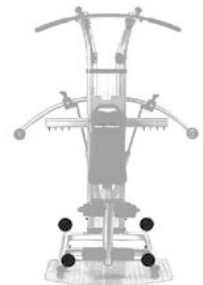

MUSCLE GROUPS EXERCISED: Biceps, forearm flexors

LEVEL OF DIFFICULTY: Intermediate/Advanced

82 SINGLE ARM STANDING BICEPS CURL

START: Stand facing away. Feet hip width apart on base. Grip one handle in underhand grip with thumb facing outward.

MOTION: Bend elbow and curl handle toward front of shoulder. Pause at top of motion. Lower arm to starting position.

TIPS: Hold elbow at side of ribcage. Do not swing elbow forward while curling. Maintain upright posture throughout exercise. Avoid tilting torso to one side while curling arm. Contract abdominals to stabilize torso. Perform on both sides.

SEAT: Off

LEG LIFT: Off

ACCESSORIES:
Handles

MOVABLE PULLEY POSITIONS



MUSCLE GROUPS EXERCISED: Biceps, forearm extensors

LEVEL OF DIFFICULTY: Beginner

83 STANDING HAMMER CURL

START: Stand facing away. Feet hip width apart on base. Grip handles in neutral grip with thumbs facing forward.

MOTION: Bend elbows and curl handles toward front of shoulders. Pause at top of motion. Lower arms to starting position.

TIPS: Hold elbows at sides of ribcage. Do not swing elbows forward while curling. Maintain upright posture throughout exercise. Avoid tilting torso back while curling arms. Contract abdominals to stabilize torso.

SEAT: Off

LEG LIFT: Off

ACCESSORIES:
Handles

MOVABLE PULLEY POSITIONS





MUSCLE GROUPS EXERCISED: Biceps, forearm extensors

LEVEL OF DIFFICULTY: Intermediate/Advanced

84 SINGLE ARM STANDING HAMMER CURL

START: Stand facing away. Feet hip width apart on base. Grip one handle in neutral grip with thumb facing forward.

MOTION: Bend elbow and curl handle toward front of shoulder. Pause at top of motion. Lower arm to starting position.

TIPS: Hold elbow at side of ribcage. Do not swing elbow forward while curling. Maintain upright posture throughout exercise. Avoid tilting torso to one side while curling arm. Contract abdominals to stabilize torso. Perform on both sides.

SEAT: Off

LEG LIFT: Off

ACCESSORIES:
Handles

MOVABLE PULLEY POSITIONS

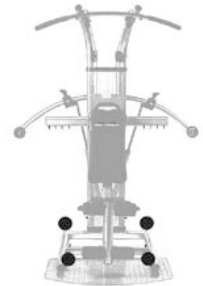

MUSCLE GROUPS EXERCISED: Biceps, forearm extensors

LEVEL OF DIFFICULTY: Intermediate

85 STANDING REVERSE CURL

START: Stand facing away. Feet hip width apart on base. Grip handles in overhand grip with thumbs facing inward.

MOTION: Bend elbows and curl handles toward front of shoulders. Pause at top of motion. Lower arms to starting position.

TIPS: Hold elbows at sides of ribcage. Do not swing elbows forward while curling. Maintain upright posture throughout exercise. Avoid tilting torso back while curling arms. Contract abdominals to stabilize torso.

SEAT: Off

LEG LIFT: Off

ACCESSORIES:
Handles

MOVABLE PULLEY POSITIONS

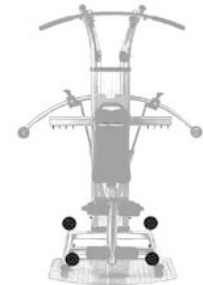

MUSCLE GROUPS EXERCISED: Biceps, forearm extensors

LEVEL OF DIFFICULTY: Intermediate/Advanced

86 SINGLE ARM STANDING REVERSE CURL

START: Stand facing away. Feet hip width apart on base. Grip one handle in overhand grip with thumb facing inward.

MOTION: Bend elbow and curl handle toward front of shoulder. Pause at top of motion. Lower arm to starting position.

TIPS: Hold elbow at side of ribcage. Do not swing elbow forward while curling. Maintain upright posture throughout exercise. Avoid tilting torso to one side while curling arm. Contract abdominals to stabilize torso. Perform on both sides.

SEAT: Off

LEG LIFT: Off

ACCESSORIES:
Handles

MOVABLE PULLEY POSITIONS





MUSCLE GROUPS EXERCISED: Biceps, forearm flexors

LEVEL OF DIFFICULTY: Beginner

87 CURVED BAR BICEPS CURL

START: Stand facing frame. Feet hip width apart on base. Grip lat bar in underhand grip with thumbs facing outward.

MOTION: Bend elbows and curl bar toward front of shoulders. Pause at top of motion. Lower arms to starting position.

TIPS: Hold elbows at sides of ribcage. Do not swing elbows forward while curling. Maintain upright posture throughout exercise. Avoid tilting torso back while curling arms. Contract abdominals to stabilize torso.

SEAT: Off

LEG LIFT: Off

ACCESSORIES: Lat Bar/Front Position

MOVABLE PULLEY POSITIONS



MUSCLE GROUPS EXERCISED: Biceps, forearm extensors

LEVEL OF DIFFICULTY: Intermediate

88 CURVED BAR REVERSE BICEPS CURL

START: Stand facing frame. Feet hip width apart on base. Grip lat bar in overhand grip with thumbs facing inward.

MOTION: Bend elbows and curl bar toward front of shoulders. Pause at top of motion. Lower arms to starting position.

TIPS: Hold elbows at sides of ribcage. Do not swing elbows forward while curling. Maintain upright posture throughout exercise. Avoid tilting torso back while curling arms. Contract abdominals to stabilize torso.

SEAT: Off

LEG LIFT: Off

ACCESSORIES: Lat Bar/Front Position

MOVABLE PULLEY POSITIONS



MUSCLE GROUPS EXERCISED: Biceps, forearm flexors

LEVEL OF DIFFICULTY: Beginner

89 SEATED CONCENTRATION CURL

START: Sit facing away. Lean forward and rest one arm on inside of knee. Grip one handle in underhand grip with palm facing up.

MOTION: Bend elbow and curl handle toward front of shoulder. Pause at top of motion. Lower arm to starting position.

TIPS: Lean forward with straight back. Do not round upper or lower spine. Hold upper arm in stable position on leg. Contract abdominals to stabilize torso. Perform on both sides.

SEAT: On/Bottom Position

LEG LIFT: Off

ACCESSORIES: Handles

MOVABLE PULLEY POSITIONS





MUSCLE GROUPS EXERCISED: Forearm flexors

LEVEL OF DIFFICULTY: Beginner



90 SEATED WRIST CURL

START: Sit facing away. Lean forward and rest forearms on lower thighs. Grip handles in underhand grip with palms facing up and wrists extended.

MOTION: Flex wrists and curl handles toward forearms. Pause at top of motion. Extend wrists to starting position.

TIPS: Lean forward with straight back. Do not round upper or lower spine. Avoid bending elbows or lifting forearms while flexing wrists. Contract abdominals to stabilize torso.

SEAT: On/Bottom Position

LEG LIFT: Off

ACCESSORIES: Handles

MOVABLE PULLEY POSITIONS

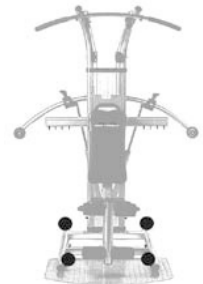

MUSCLE GROUPS EXERCISED: Forearm extensors

LEVEL OF DIFFICULTY: Beginner



91 SEATED REVERSE WRIST CURL

START: Sit facing away. Lean forward and rest forearms on lower thighs. Grip handles in overhand grip with palms facing down and wrists flexed.

MOTION: Extend wrists and curl handles toward forearms. Pause at top of motion. Flex wrists to starting position.

TIPS: Lean forward with straight back. Do not round upper or lower spine. Avoid bending elbows or lifting forearms while extending wrists. Contract abdominals to stabilize torso.

SEAT: On/Bottom Position

LEG LIFT: Off

ACCESSORIES: Handles

MOVABLE PULLEY POSITIONS



MUSCLE GROUPS EXERCISED: Triceps

LEVEL OF DIFFICULTY: Intermediate



92 SEATED OVERHEAD TRICEPS EXTENSION

START: Sit facing away. Grip handles behind head. Point elbows front at shoulder height.

MOTION: Extend elbows and press handles overhead. Pause at top of motion. Bend elbows back to starting position.

TIPS: Keep elbows in start position throughout exercise. Do not open elbows to sides. Keep wrists straight. Maintain upright posture in seated position. Contract abdominals to stabilize torso.

SEAT: On/Top Position

LEG LIFT: On

ACCESSORIES: Handles

MOVABLE PULLEY POSITIONS





MUSCLE GROUPS EXERCISED: Triceps

LEVEL OF DIFFICULTY: Intermediate/Advanced

93 SINGLE ARM OVERHEAD TRICEPS EXTENSION

START: Sit facing away. Grip one handle behind head. Point elbow front at shoulder height.

MOTION: Extend elbow and press handle overhead. Pause at top of motion. Bend elbow back to starting position.

TIPS: Keep elbow in start position throughout exercise. Do not open elbow to side. Maintain upright posture in seated position. Avoid tilting or rotating to one side while extending arm. Contract abdominals to stabilize torso. Perform on both sides.

SEAT: On/Top Position

LEG LIFT: On

ACCESSORIES: Handles

MOVABLE PULLEY POSITIONS

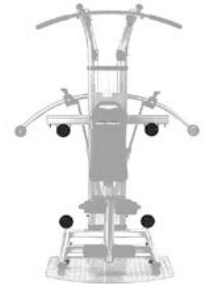

MUSCLE GROUPS EXERCISED: Triceps

LEVEL OF DIFFICULTY: Beginner

94 STANDING TRICEPS PUSHDOWN

START: Stand facing frame. Feet hip width apart on base. Grip lat bar in overhand, shoulder width grip with palms facing down. Bend elbows 90 degrees.

MOTION: Extend elbows and press bar down toward thighs. Pause at bottom of motion. Bend elbows back to starting position.

TIPS: Hold elbows at sides of ribcage. Do not move upper arms while extending elbows. Maintain upright posture throughout exercise. Avoid rounding spine forward while pressing down. Contract abdominals to stabilize torso.

SEAT: Off

LEG LIFT: Off

ACCESSORIES: Lat Bar/Lat Tower Position

MOVABLE PULLEY POSITIONS



MUSCLE GROUPS EXERCISED: Triceps

LEVEL OF DIFFICULTY: Intermediate

95 REVERSE GRIP TRICEPS PUSHDOWN

START: Stand facing frame. Feet hip width apart on base. Grip lat bar in underhand, shoulder width grip with palms facing up. Bend elbows 90 degrees.

MOTION: Extend elbows and press bar down toward thighs. Pause at bottom of motion. Bend elbows back to starting position.

TIPS: Hold elbows at sides of ribcage. Do not move upper arms while extending elbows. Maintain upright posture throughout exercise. Avoid rounding spine forward while pressing down. Contract abdominals to stabilize torso.

SEAT: Off

LEG LIFT: Off

ACCESSORIES: Lat Bar/Lat Tower Position

MOVABLE PULLEY POSITIONS





MUSCLE GROUPS EXERCISED: Triceps

LEVEL OF DIFFICULTY: Beginner

96 SPLIT GRIP TRICEPS PUSHDOWN

START: Stand facing frame. Feet hip width apart on base. Grip handles at waist level. Bend elbows 90 degrees.

MOTION: Extend elbows and press handles down. Pause at end of motion. Bend elbows back to starting position.

TIPS: Keep arms close to sides of body. Press handles down and slightly back. Maintain upright posture throughout exercise. Avoid rounding spine forward while pressing down. Contract abdominals to stabilize torso.

SEAT: Off

LEG LIFT: Off

ACCESSORIES: Handles/Lat Tower Position

MOVABLE PULLEY POSITIONS



MUSCLE GROUPS EXERCISED: Triceps

LEVEL OF DIFFICULTY: Intermediate/Advanced

97 SINGLE ARM TRICEPS PUSHDOWN

START: Stand facing frame. Feet hip width apart on base. Grip one handle in overhand grip with palm facing down. Bend elbow 90 degrees.

MOTION: Extend elbow and press handle down toward thigh. Pause at bottom of motion. Bend elbow back to starting position.

TIPS: Hold elbow at side of ribcage. Do not move upper arm while extending elbow. Maintain upright posture throughout exercise. Avoid rounding spine forward while pressing down. Contract abdominals to stabilize torso. Perform on both sides.

SEAT: Off

LEG LIFT: Off

ACCESSORIES: Handles/Lat Tower Position

MOVABLE PULLEY POSITIONS



MUSCLE GROUPS EXERCISED: Triceps

LEVEL OF DIFFICULTY: Intermediate/Advanced

98 SINGLE ARM REVERSE GRIP TRICEPS PUSHDOWN

START: Stand facing frame. Feet hip width apart on base. Grip one handle in underhand grip with palm facing up. Bend elbow 90 degrees.

MOTION: Extend elbow and press handle down toward thigh. Pause at bottom of motion. Bend elbow back to starting position.

TIPS: Hold elbow at side of ribcage. Do not move upper arm while extending elbow. Maintain upright posture throughout exercise. Avoid rounding spine forward while pressing down. Contract abdominals to stabilize torso. Perform on both sides.

SEAT: Off

LEG LIFT: Off

ACCESSORIES: Handles/Lat Tower Position

MOVABLE PULLEY POSITIONS





MUSCLE GROUPS EXERCISED: Triceps

LEVEL OF DIFFICULTY: Beginner

99 SINGLE ARM TRICEPS KICKBACK

START: Stand facing frame. Grip one handle in overhand grip with palm facing down. Bend elbow 90 degrees. Lean forward slightly and place other hand on seat back.

MOTION: Extend elbow and pull handle down and back. Pause at end of motion. Bend elbow back to starting position.

TIPS: Keep arm close to side of body. Do not allow wrist to bend while pressing back. Maintain straight spine while leaning forward. Contract abdominals to stabilize torso. Perform on both sides.

SEAT: Off

LEG LIFT: Off

ACCESSORIES:
Handles

MOVABLE PULLEY POSITIONS



MUSCLE GROUPS EXERCISED: Triceps

LEVEL OF DIFFICULTY: Intermediate/Advanced

100 SINGLE ARM REVERSE GRIP TRICEPS KICKBACK

START: Stand facing frame. Grip one handle in underhand grip with palm facing up. Bend elbow 90 degrees. Lean forward slightly and place other hand on seat back.

MOTION: Extend elbow and pull handle down and back. Pause at end of motion. Bend elbow back to starting position.

TIPS: Keep arm close to side of body. Do not allow wrist to bend while pressing back. Maintain straight spine while leaning forward. Contract abdominals to stabilize torso. Perform on both sides.

SEAT: Off

LEG LIFT: Off

ACCESSORIES:
Handles

MOVABLE PULLEY POSITIONS



MUSCLE GROUPS EXERCISED: Triceps

LEVEL OF DIFFICULTY: Intermediate

101 TWO ARM TRICEPS KICKBACK

START: Stand facing frame. Grip handles in overhand grip with palms facing down. Bend elbows 90 degrees.

MOTION: Extend elbows and pull handles down and back. Pause at end of motion. Bend elbows back to starting position.

TIPS: Keep arms close to sides of body. Do not allow wrists to bend while pressing back. Maintain upright posture throughout exercise. Do not lean forward while pressing back. Contract abdominals to stabilize torso.

SEAT: Off

LEG LIFT: Off

ACCESSORIES:
Handles

MOVABLE PULLEY POSITIONS





MUSCLE GROUPS EXERCISED: Triceps

LEVEL OF DIFFICULTY: Intermediate

102 TWO ARM REVERSE GRIP TRICEPS KICKBACK

START: Stand facing frame. Grip handles in underhand grip with palms facing up. Bend elbows 90 degrees.

MOTION: Extend elbows and pull handles down and back. Pause at end of motion. Bend elbows back to starting position.

TIPS: Keep arms close to sides of body. Do not allow wrists to bend while pressing back. Maintain upright posture throughout exercise. Do not lean forward while pressing back. Contract abdominals to stabilize torso.

SEAT: Off

LEG LIFT: Off

ACCESSORIES:
Handles

MOVABLE PULLEY POSITIONS

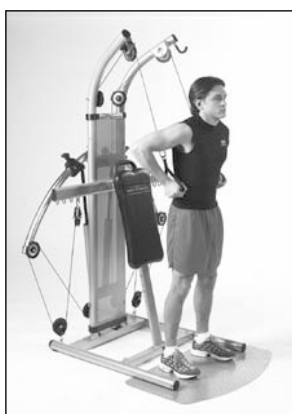

MUSCLE GROUPS EXERCISED: Triceps, anterior deltoids, pectoralis

LEVEL OF DIFFICULTY: Beginner

103 TRICEPS DIPS

START: Stand facing away. Grip handles at waist level. Bend elbows 90 degrees. Cables behind arms.

MOTION: Extend elbows and press handles down. Pause at end of motion. Bend elbows back to starting position.

TIPS: Keep arms close to sides of body. Press down and slightly forward. Maintain upright posture throughout exercise. Avoid rounding spine forward while pressing down. Contract abdominals to stabilize torso.

SEAT: Off

LEG LIFT: Off

ACCESSORIES:
Handles/Lat Tower Position

MOVABLE PULLEY POSITIONS



MUSCLE GROUPS EXERCISED: Triceps, anterior deltoids, pectoralis

LEVEL OF DIFFICULTY: Intermediate/Advanced

104 SINGLE ARM TRICEPS DIPS

START: Stand facing away. Grip one handle at waist level. Bend elbow 90 degrees. Cable behind arm.

MOTION: Extend elbow and press handle down. Pause at end of motion. Bend elbow back to starting position.

TIPS: Keep arm close to side of body. Press down and slightly forward. Maintain upright posture throughout exercise. Avoid rounding spine forward while pressing down. Contract abdominals to stabilize torso. Perform on both sides.

SEAT: Off

LEG LIFT: Off

ACCESSORIES:
Handles/Lat Tower Position

MOVABLE PULLEY POSITIONS





MUSCLE GROUPS EXERCISED: Triceps

LEVEL OF DIFFICULTY: Intermediate

105 CROSS-BODY TRICEPS EXTENSION

START: Sit facing away. Bend one elbow and reach across body to grip handle at opposite shoulder.

MOTION: Extend elbow and press handle in front of body. Pause at end of motion. Bend elbow back to starting position.

TIPS: Keep elbow at shoulder height. Do not bend wrist while extending elbow. Maintain upright posture in seated position. Contract abdominals to stabilize torso. Perform on both sides.

SEAT: On/Top Position

LEG LIFT: On

ACCESSORIES: Handles

MOVABLE PULLEY POSITIONS





MUSCLE GROUPS EXERCISED: Abdominals

LEVEL OF DIFFICULTY: Beginner

106 AB CRUNCH

START: Sit facing away. Grip handles at shoulder level. Elbows point front.

MOTION: Curl spine, pulling bottom of ribcage down toward hips. Pause at end of motion. Return to starting position.

TIPS: Do not pull down with arms. Focus work in abdominal muscles. Extend torso to upright seated position after each repetition. Keep neck in line with spine.

SEAT: On/Bottom Position

LEG LIFT: On

ACCESSORIES: Handles/Lat Tower

MOVABLE PULLEY POSITIONS



MUSCLE GROUPS EXERCISED: Abdominals, obliques

LEVEL OF DIFFICULTY: Intermediate

107 OBLIQUE CRUNCH

START: Sit facing away. Grip handles at shoulder level. Elbows point front.

MOTION: Curl spine and simultaneously rotate torso toward one knee. Pause at end of motion. Return to starting position.

TIPS: Do not pull down with arms. Focus work in abdominal muscles. Extend torso to upright seated position after each repetition. Keep neck in line with spine. Perform on both sides.

SEAT: On/Bottom Position

LEG LIFT: On

ACCESSORIES: Handles/Lat Tower

MOVABLE PULLEY POSITIONS

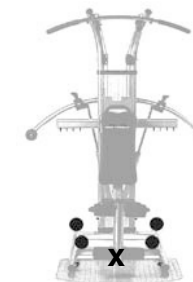

MUSCLE GROUPS EXERCISED: Abdominals, obliques

LEVEL OF DIFFICULTY: Intermediate

108 STANDING TRUNK ROTATION

START: Stand facing side. Feet hip width apart on base. Rotate torso inward. Grip one handle with both hands.

MOTION: Rotate trunk outward. Pause at end of motion. Rotate inward to starting position.

TIPS: Keep arms straight in front of torso. Rotate trunk rather than pulling with arms. Maintain upright posture throughout exercise. Do not round lower back while rotating. Perform on both sides.

SEAT: Off

LEG LIFT: Off

ACCESSORIES: Handles

MOVABLE PULLEY POSITIONS





MUSCLE GROUPS EXERCISED: Abdominals, obliques, lateral flexors

LEVEL OF DIFFICULTY: Intermediate

109 SIDE BEND

START: Stand facing side. Feet hip width apart on base. Grip one handle with inside hand.

MOTION: Flex trunk laterally, away from handle. Pause at end of motion. Return to starting position.

TIPS: Keep arm straight. Laterally flex trunk, rather than pulling with arm. Contract abdominals to stabilize spine. Perform on both sides.

SEAT: Off

LEG LIFT: Off

ACCESSORIES:
Handles

MOVABLE PULLEY POSITIONS

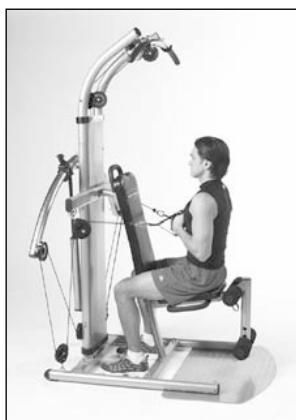
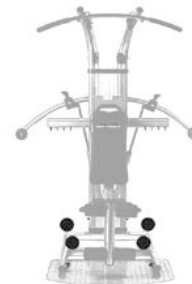

MUSCLE GROUPS EXERCISED: Spinal extensors

LEVEL OF DIFFICULTY: Intermediate

110 SEATED SPINAL EXTENSION

START: Sit facing frame. Grip handles in front of chest. Pull elbows to waist.

MOTION: Extend spine. Pause at end of motion. Return to starting position.

TIPS: Lift ribcage and lengthen spine while extending. Do not over extend spine. Keep elbows in close to body. Avoid pulling with arms. Contract abdominals to stabilize lower back.

SEAT: On/Bottom Position

LEG LIFT: On

ACCESSORIES:
Handles

MOVABLE PULLEY POSITIONS



TAURUS

Multi-gym UltraForce