

TAURUS®

Assembly and Operating Instructions

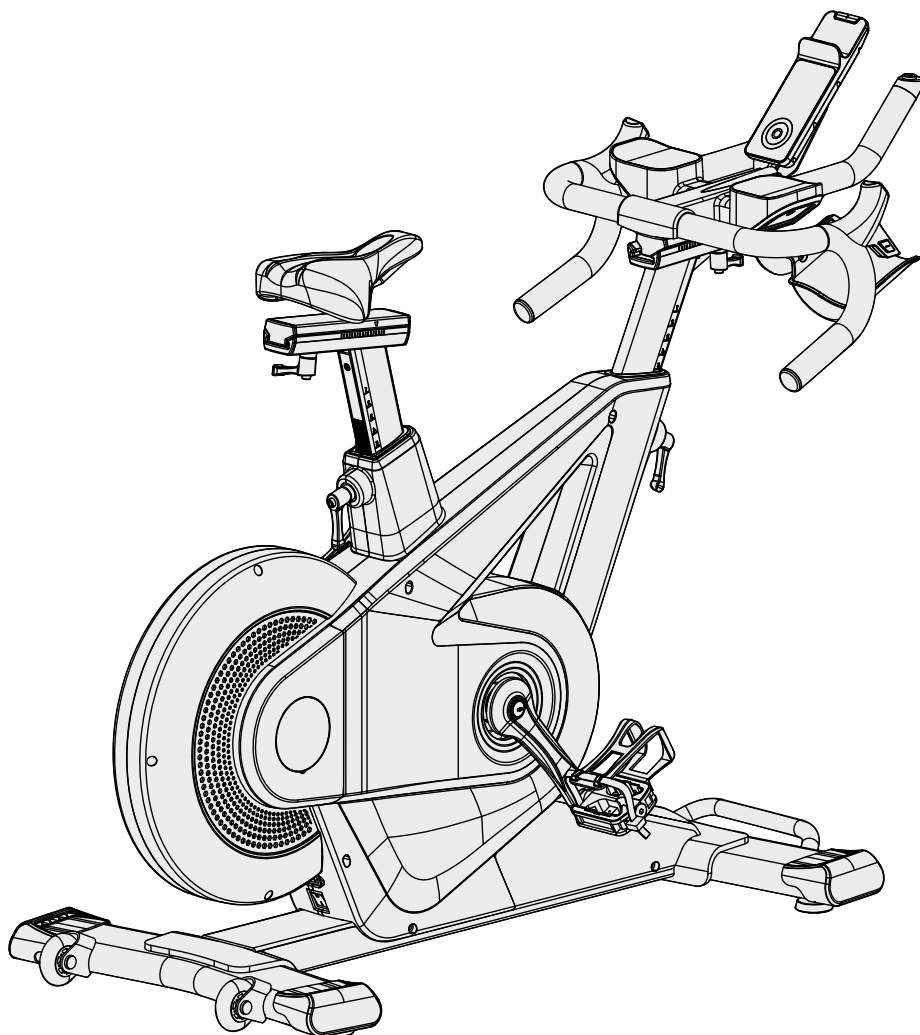

max. 180 kg



~ 60 Min.



59 kg

L 157 | W 60 | H 137

TFRACER.01.01

Art. No. TF-RACER

Taurus Racer Pro

Content

1	GENERAL INFORMATION	7
1.1	Technical Data	7
1.2	Personal Safety	8
1.3	Set-Up Place	10
2	ASSEMBLY	11
2.1	General Instructions	11
2.2	Scope of Delivery	12
2.3	Assembly	14
3	OPERATING INSTRUCTIONS	23
3.1	Console Display	23
3.2	Button Functions	24
3.3	Turning on the Console and Standby Mode	25
3.4	Programmes	25
3.4.1	Quick Start Function and Target Programmes (M)	26
3.4.2	Preset Programmes (P)	26
3.4.3	User Defined Programmes (U)	27
3.4.4	Heart Rate Controlled Programme (H)	27
3.4.5	Watt Programme (W)	28
3.5	Recovery Function	28
3.6	Compatibility Training Apps	29
3.6.1	Connection with Kinomap	29
4	STORAGE AND TRANSPORT	31
4.1	General Instructions	31
4.2	Transportation Wheels	31
5	TROUBLESHOOTING, CARE AND MAINTENANCE	32
5.1	General Instructions	32
5.2	Faults and Fault Diagnosis	32
5.3	Error Codes and Troubleshooting	33
5.4	Maintenance and Inspection Calendar	34
6	DISPOSAL	34
7	RECOMMENDED ACCESSORIES	35
8	ORDERING SPARE PARTS	36

8.1	Serial Number and Model Name	36
8.2	Parts List	37
8.3	Exploded Drawing	42

9	WARRANTY	43
---	----------	----

10	CONTACT	45
----	---------	----

Dear customer,

Thank you for choosing a high-quality equipment of the brand Taurus®. Taurus® offers sports and fitness equipment for the sophisticated home sport and the equipment of fitness studios and business customers. With Taurus® fitness equipment, the focus is on what sport is all about: maximum performance! Therefore, the equipment is developed in close consultation with athletes and sports scientists. Because athletes know best what makes perfect fitness equipment.

Further information can be found at www.sport-tiedje.com.

Intended Use

The equipment may only be used for its intended purpose.

This fitness equipment is suitable for home use, semi-professional use and commercial or professional use. The semi-professional sector includes, for example, institutional facilities such as hospitals, schools, hotels and associations. Professional use refers to commercial use, e.g. in a fitness studio.

Disclaimer

©2011 Taurus® is a registered brand of the company Sport-Tiedje GmbH. All rights reserved. Any use of this trademark without the explicit written permission of Sport-Tiedje is prohibited.

Product and manual are subject to change. Technical data can be changed without advance notice.

ABOUT THIS MANUAL

Please carefully read the entire manual before installation and first use. The manual will help you to quickly set up the system and explains how to safely use it. Make sure that all persons exercising with the equipment (especially children and persons with physical, sensory, mental or motor disabilities) are informed about this manual and its contents in advance. In case of doubt, responsible persons must supervise the use of the equipment.

Due to ongoing changes and software optimisations, the manual may have to be updated. If you notice any discrepancies during assembly or use, please refer to the manual uploaded to the webshop. The latest manual is always available there.



This equipment has been manufactured according to the latest safety knowledge. As far as possible, potential safety hazards which could cause injury have been eliminated. Make sure to carefully follow the instructions and that all parts are securely in place. If required, read through the instructions again to correct any mistakes.

Please pay close attention to the safety and maintenance instructions given here. The contract partner cannot be held liable for damage to health, accidents or damage to the equipment when it is not used in accordance with these instructions.

The following safety instructions may appear in this manual:

► **ATTENTION**

This notice indicates potentially hazardous situations which, if not avoided, may result in property damage.

⚠ **CAUTION**

This notice indicates potentially hazardous situations which, if not avoided, may result in slight or minor injuries!

⚠ **WARNING**

This notice indicates potentially hazardous situations which, if not avoided, may result in death or serious injuries!

⚠ **DANGER**

This notice indicates potentially hazardous situations which, if not avoided, will result in death or serious injuries!

ⓘ **NOTICE**

This notice indicates further useful information.

Retain these instructions in a safe place for future reference, maintenance or when ordering replacement parts.

1.1 Technical Data

LED Display:

- + Training time
- + Speed
- + Revolutions per minute
- + Distance
- + Calories burned
- + Pulse (when using a compatible chest strap)
- + Watt
- + Resistance level

Resistance system:	induction brake system
Resistance levels:	80
Flywheel mass:	12 kg

Wattage	
Min. and max. watt at 60 RPM:	30 - 650 W
Min. and max. watt at 100 RPM:	58 - 1074 W

Weight and Dimensions

Packaging dimensions (L x W x H) approx.:	125.5 cm x 27.5 cm x 94 cm
Set-up dimensions (L x W x H) approx.:	157 cm x 60 cm x 136.5 cm

Article weight (gross, incl. packaging) approx.:	65 kg
Article weight (net, excl. packaging) approx.:	58.5 kg

Maximum user weight:	180 kg
----------------------	--------

Q-factor:	16.5 cm
-----------	---------

Class:	S
--------	---

1.2 Personal Safety

DANGER

- + Before you start using the equipment, you should consult your physician that this type of exercise is suitable for you from a health perspective. Particularly affected are persons who: have a hereditary disposition to high blood pressure or heart disease, are over the age of 45, smoke, have high cholesterol values, are overweight and/or have not exercised regularly in the past year. If you are under medical treatment that affects your heart rate, medical advice is absolutely essential.
- + Note that excessive training can seriously endanger your health. Please also note that heart rate monitoring systems can be inaccurate. If you notice any signs of weakness, nausea, dizziness, pain, shortness of breath, or other abnormal symptoms, stop exercising immediately and seek advice from your doctor if necessary.
- + Always start your training with low intensity and increase evenly and gently. End your training with a cool-down phase. If you are unsure, consult your physician.

WARNING

- + This equipment may not be used by children under the age of 14.
- + Children should not be allowed unsupervised access to the equipment.
- + Persons with disabilities must have a medical license and must be under strict observation when using the equipment.
- + The equipment is strictly for use by one person at a time.
- + If your equipment provides a safety key, the clip of the safety key must be attached to your clothing before starting your training. In the event of a fall, the EMERGENCY STOP of the equipment can be initiated.
- + Keep your hands, feet and other body parts, hair, clothing, jewellery and other objects well clear of moving parts.
- + During use, wear suitable sports clothing rather than loose or baggy clothing. When wearing sports shoes, make sure they have suitable soles, preferably made of rubber or other non-slip materials. Shoes with heels, leather soles, studs or spikes are unsuitable. Never exercise barefoot.
- + Support yourself with at least one hand on the handlebar when getting on and off the equipment. Only dismount from the equipment when the pedals have come to a complete stop.
- + There is a risk of injury from spinning pedals and/or an exposed flywheel in the absence of a freewheel. Never get on or off the equipment when the pedals or the flywheel are still moving. Always make sure that the pedals and the flywheel have come to a complete stop.
- + Always use fasteners (e.g. pedal straps, pedal cage, click system) that hold the foot in one position.

CAUTION

- + If your equipment needs to be connected to the power supply with a mains cable, make sure that the cable is not a potential tripping hazard.
- + Make sure that nobody is within the range of motion of the equipment during training so as not to endanger you or other persons.
- + Be aware that if adjustment devices are left protruding, they may impede the user's movement.

► **ATTENTION**

- + Do not insert any objects of any kind into the openings of the device. Electrical Safety

⚠ **DANGER**

- + In order to reduce the risk of an electric shock, always unplug the equipment from the mains socket immediately after your workout, before assembly or dismantling, and before maintenance or cleaning. Do not pull on the cable.

⚠ **WARNING**

- + Do not leave the equipment unattended while the mains cable is plugged into the mains socket. During your absence, the mains cable must be removed from the mains socket to prevent improper use by third parties or children.
- + If the mains cable or plug is damaged or defective, contact your contract partner. Until repair, the equipment must not be used.

► **ATTENTION**

- + The equipment requires a mains connection of 220-230 V with 50 Hz mains voltage.
- + The equipment may only be connected directly to an earthed socket using the supplied mains cable. Extension cables must conform to VDE guidelines. Always completely unwind the mains cable.
- + The socket must be protected by a fuse with a minimum fuse rating of "16 A, slow blow".
- + Do not make any changes to the mains cable or the mains plug.
- + Keep the mains cable away from water, heat, oil and sharp edges. Do not route the mains cable underneath the equipment or under a carpet or rug, and do not place any objects on top of it.
- + If your purchased item is equipped with a TFT console, software updates must be carried out regularly. Follow the instructions on the console to perform the update(s).
- + The software systems on gym equipment with TFT consoles are set up only for the pre-installed apps. Do not install any additional apps.

ⓘ **NOTICE**

- + The pre-installed apps on TFT consoles are produced and provided by external manufacturers. Sport-Tiedje does not take any responsibility for the availability, functionality or contents of these apps.

1.3 Set-Up Place

⚠ WARNING

- + Do not place the equipment in main corridors or escape routes.

⚠ CAUTION

- + Choose a location in which to place the equipment such that there is enough free space/clearance to the front, the rear and to the sides of the equipment.
- + The training room should be well ventilated during training and not be exposed to any draughts.
- + Choose the place in which to set up the equipment such that there is enough free space/clearance to the front, the rear and to the sides of the equipment.
- + The free area in the direction from which the exercise equipment is accessed must be at least 0.6 m larger than the exercise area.
- + The set-up and mounting surface of the equipment should be flat, loadable and solid.
- + Class S exercise equipment must always be used in supervised areas.

▶ ATTENTION

- + The device may only be used in one building, in sufficiently tempered and dry rooms (ambient temperatures between 10°C and 35°C). The equipment should not be used outdoors or in rooms with high humidity (over 70%) like swimming pools.
- + A floor protective mat/equipment underlay can help to protect high-quality floor coverings (parquet, laminate, cork, carpets) from dents and sweat and can help to level out slight unevenness.

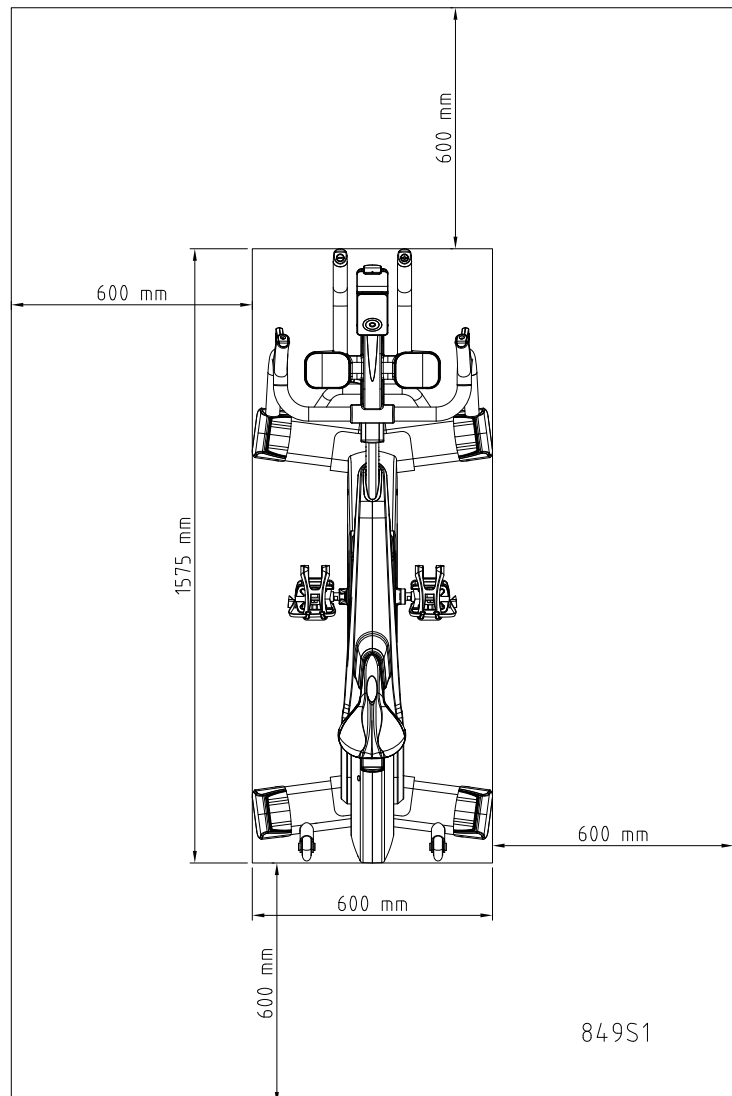

2.1 General Instructions

⚠ DANGER

- + Do not leave any tools, packaging materials such as foils or small parts lying around, as otherwise there is a danger of suffocation for children. Keep children away from the equipment during assembly.

⚠ WARNING

- + Pay attention to the instructions attached to the equipment in order to reduce the risk of injuries.

⚠ CAUTION

- + Ensure to have sufficient room for movement in each direction during assembly.
- + The assembly of the equipment must be carried out by at least two adults. If in doubt, seek the help of a third technically skilled person.

▶ ATTENTION

- + To prevent damage to the equipment and the floor, assemble the equipment on a mat or packaging board.

ⓘ NOTICE

- + In order to make the assembly as simple as possible, some screws and nuts to be used can already be pre-assembled.
- + Ideally, assemble the equipment at its later set-up place.

2.2 Scope of Delivery

The scope of delivery consist of the following parts. At the beginning, check whether all parts and tools belonging to the device are included in the scope of delivery and whether damage has occurred. In the event of complaints, the contractual partner must be contacted directly.

 **CAUTION**

If parts of the scope of delivery are missing or damaged, the assembly must not be carried out.

Part No.	Description	Qty.
1	Main frame	1
2	Rear stabilizer	1
4	Front stabilizer	1
36	Handlebar	1
42L & 42R	Left and right handbar protective cover	1
43	Handbar protective cover	1
51L & 51R	Pedal set	1
54L & 54R	Left and right bottle holder	1
66	Power cord	1
76	Computer	1
	Screw kit	1

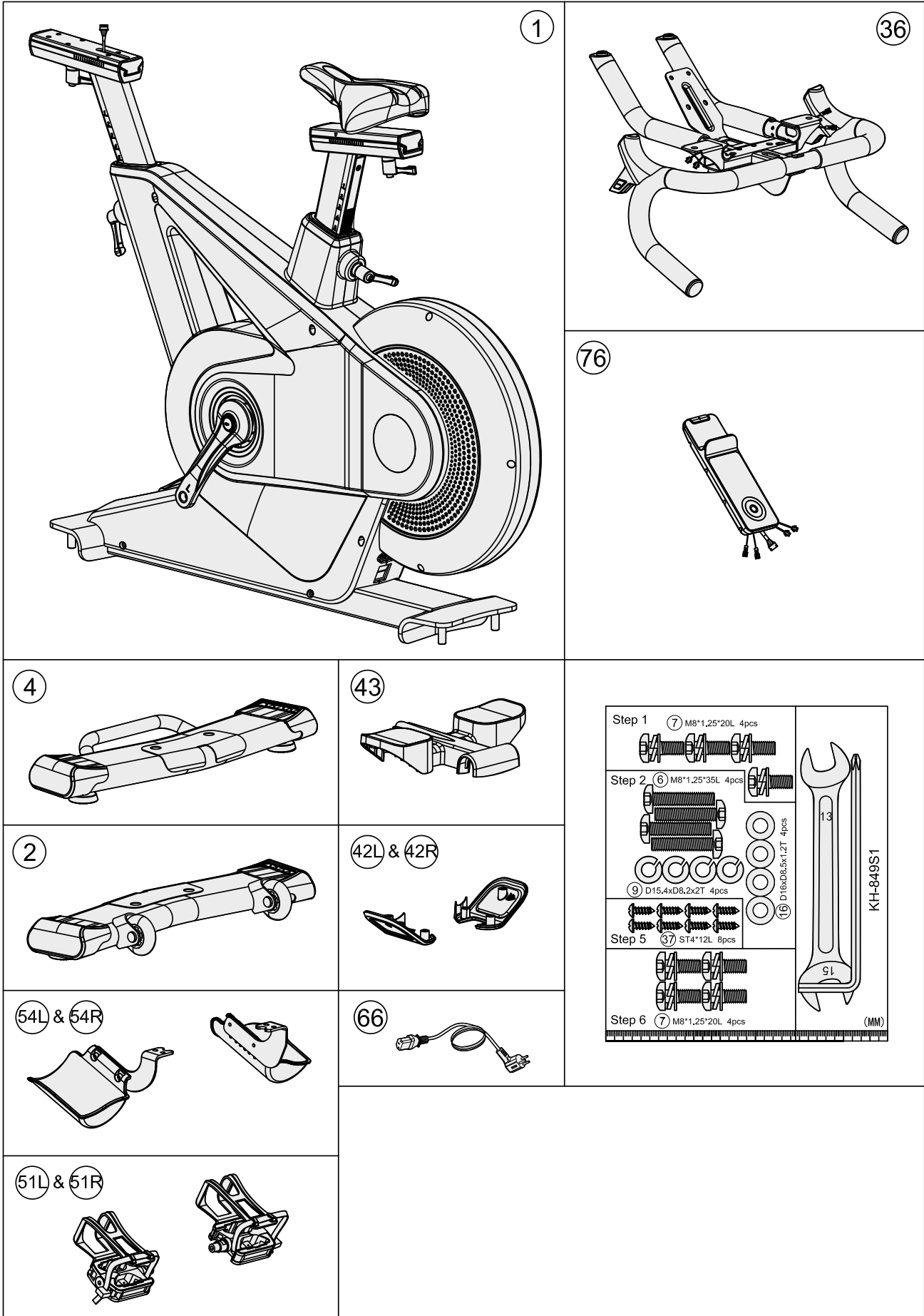

2.3 Assembly

Before assembly, take a close look at the individual assembly steps shown and carry out the assembly in the order given.

① NOTICE

- + First loosely screw all parts together and check that they fit properly. Tighten the screws using the tool only when you are instructed to do so.
- + If you have difficulty recognising the graphics, we recommend that you open and/or download the PDF instructions stored in the webshop on your end device (e.g. smartphone, tablet or PC). There you have the option of zooming in closer. Please note that the Adobe Acrobat Reader programme must be installed on your end device in order to open the file.

Step 1: Assembly of the Stabilizers

Assemble the front and rear stabilizer (4 & 2) to the main frame (1) with two screws (7) each.

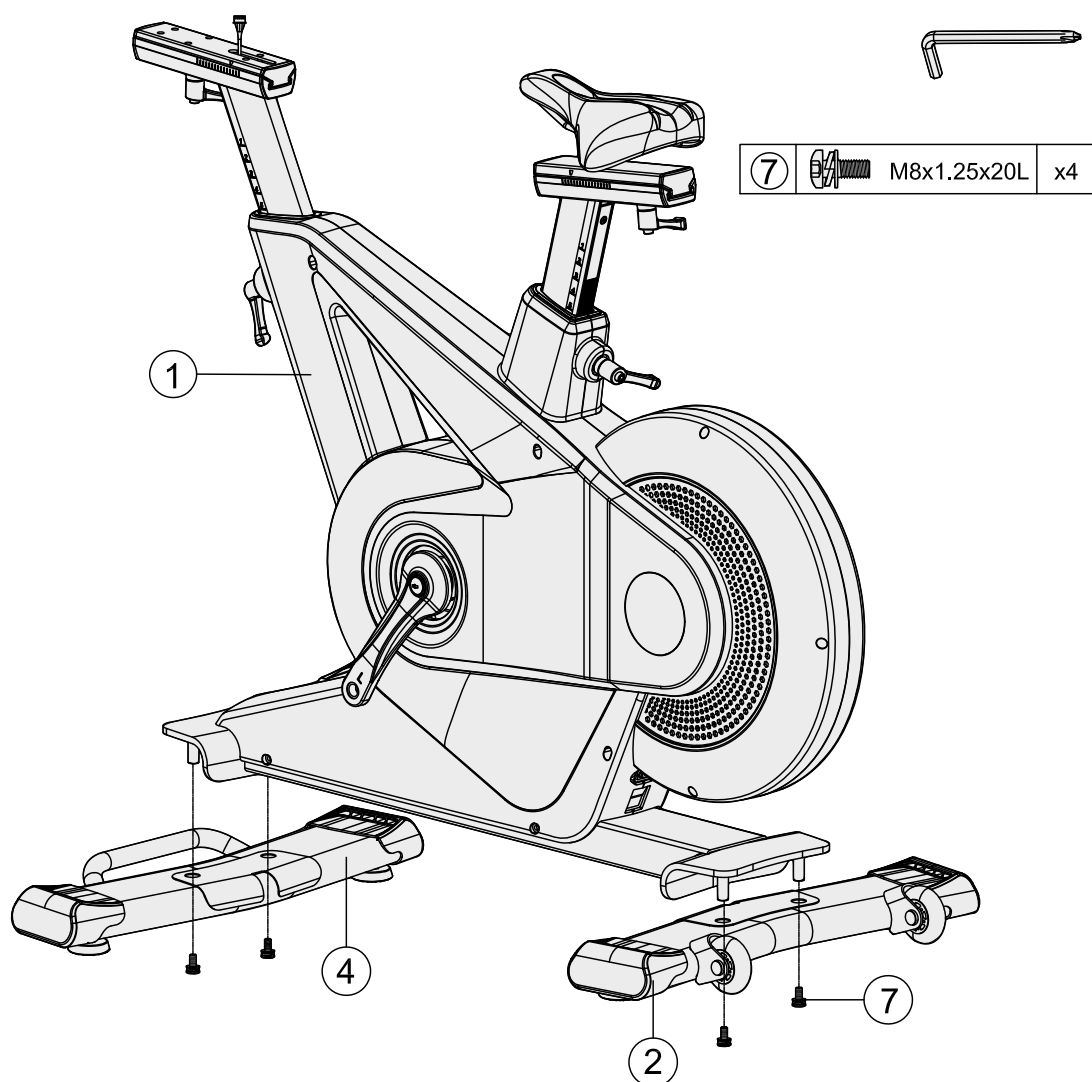

Step 2: Assembly of the Handlebar

1. Pass the middle computer cable (64) through the respective opening of the handlebar (36)

► **ATTENTION**

Be careful not to pinch the cables during the following step.

2. Assemble the handlebar (36) to the handlebar adjustable tube (17) with four screws (6), four spring washers (9) and four washers (16).

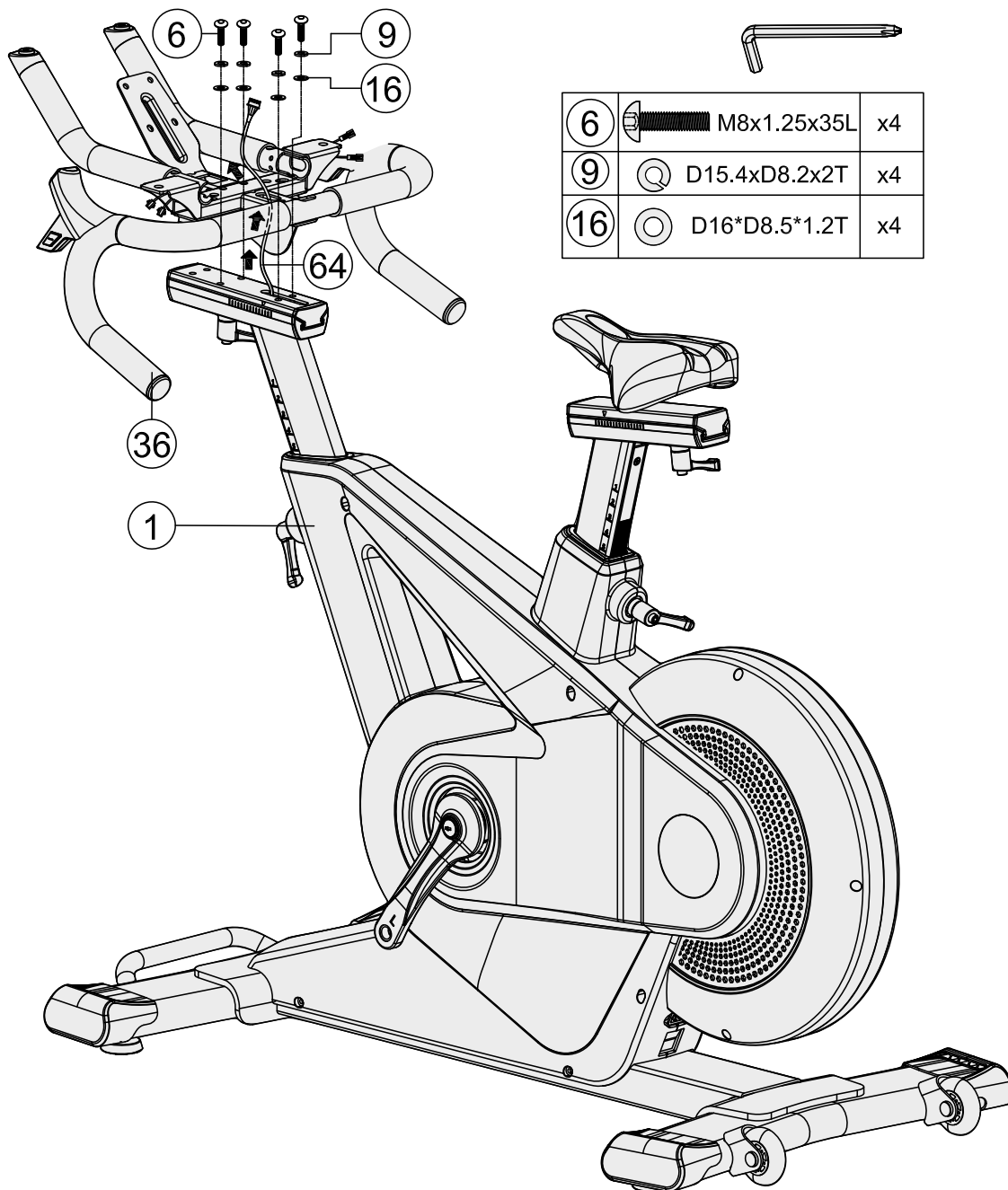

Step 3: Connection of the Console Cables

1. Connect the two left quick key cables (92L & 93L) to their corresponding counterparts (76).
2. Connect the middle computer cable (64) to its corresponding counterpart (76).
3. Connect the two right quick key cables (92R & 93R) to their corresponding counterparts (76).

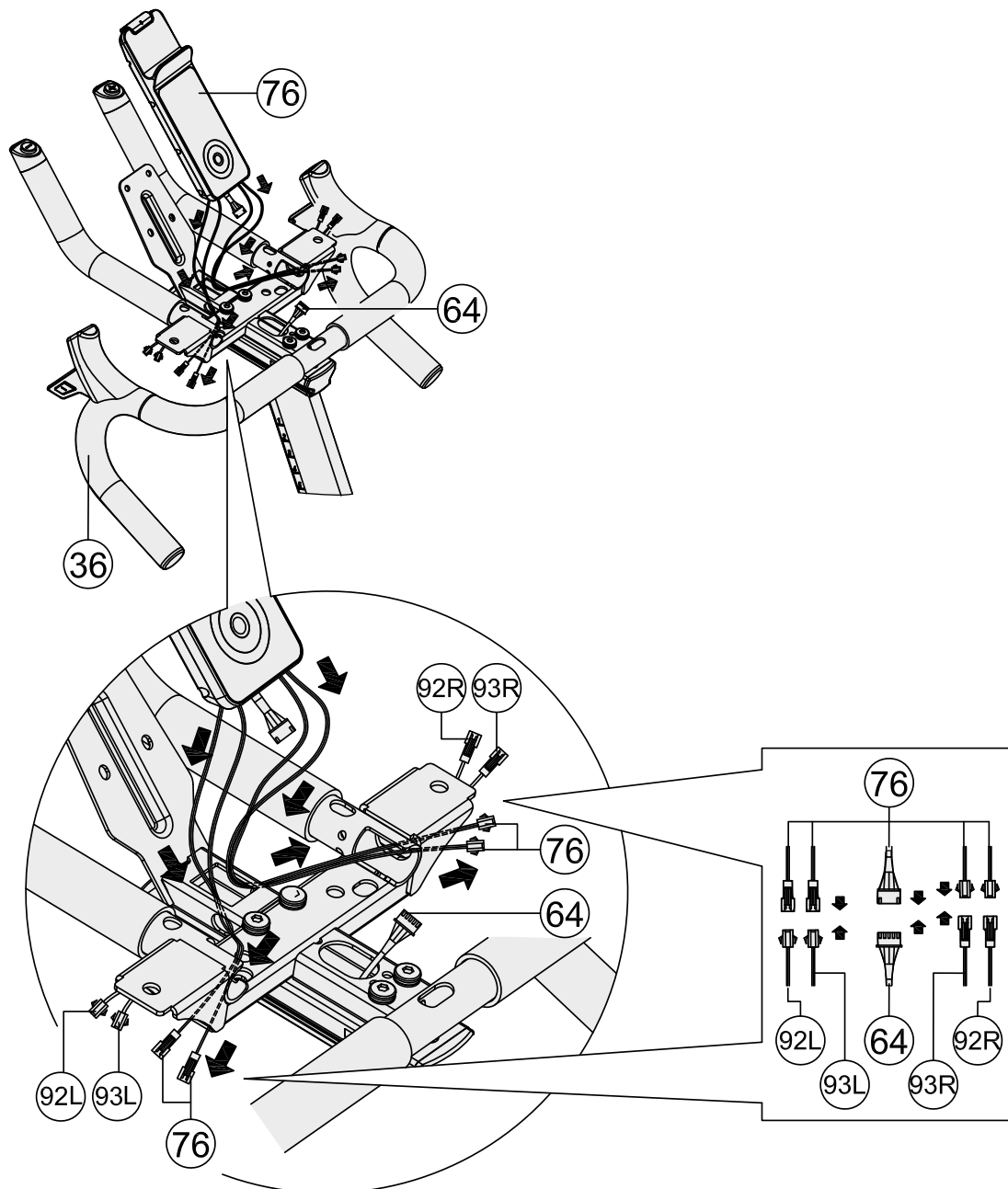

Step 4: Assembly of the Computer and the Protective Covers Part 1

► **ATTENTION**

Be careful not to pinch the cables during the following step.

1. Assemble the computer (76) on the handlebar (36) with four screws (102).

► **ATTENTION**

The middle handlebar cover is not screwed on until step 5.

2. Place the middle handbar protective cover (43) on the handlebar (36).

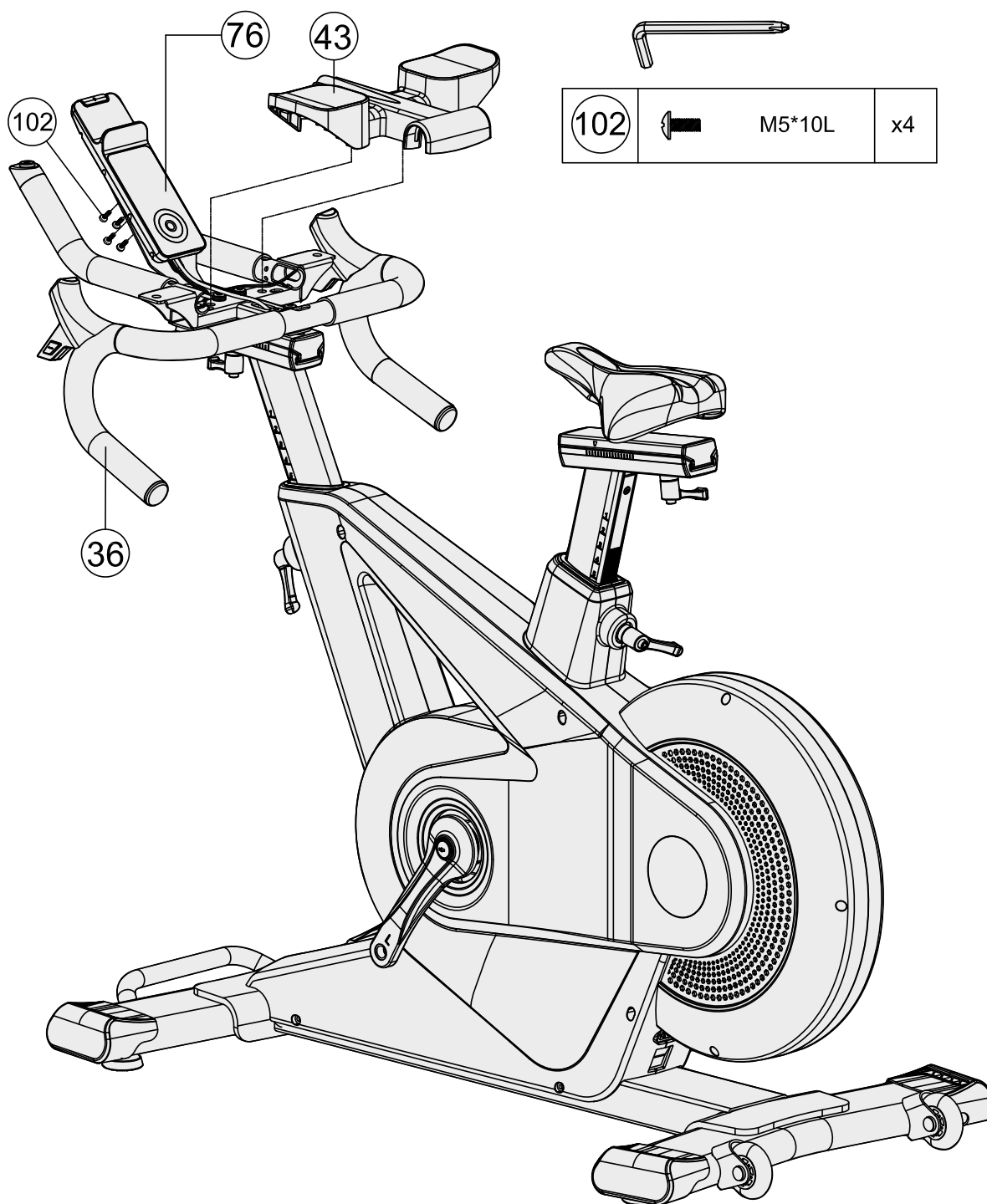

Step 5: Assembly of the Protective Covers Part 2

Assemble the center handbar protective cover (43), left handbar protective cover (42L) and right handbar protective cover (42R) with a total of eight screws (37).

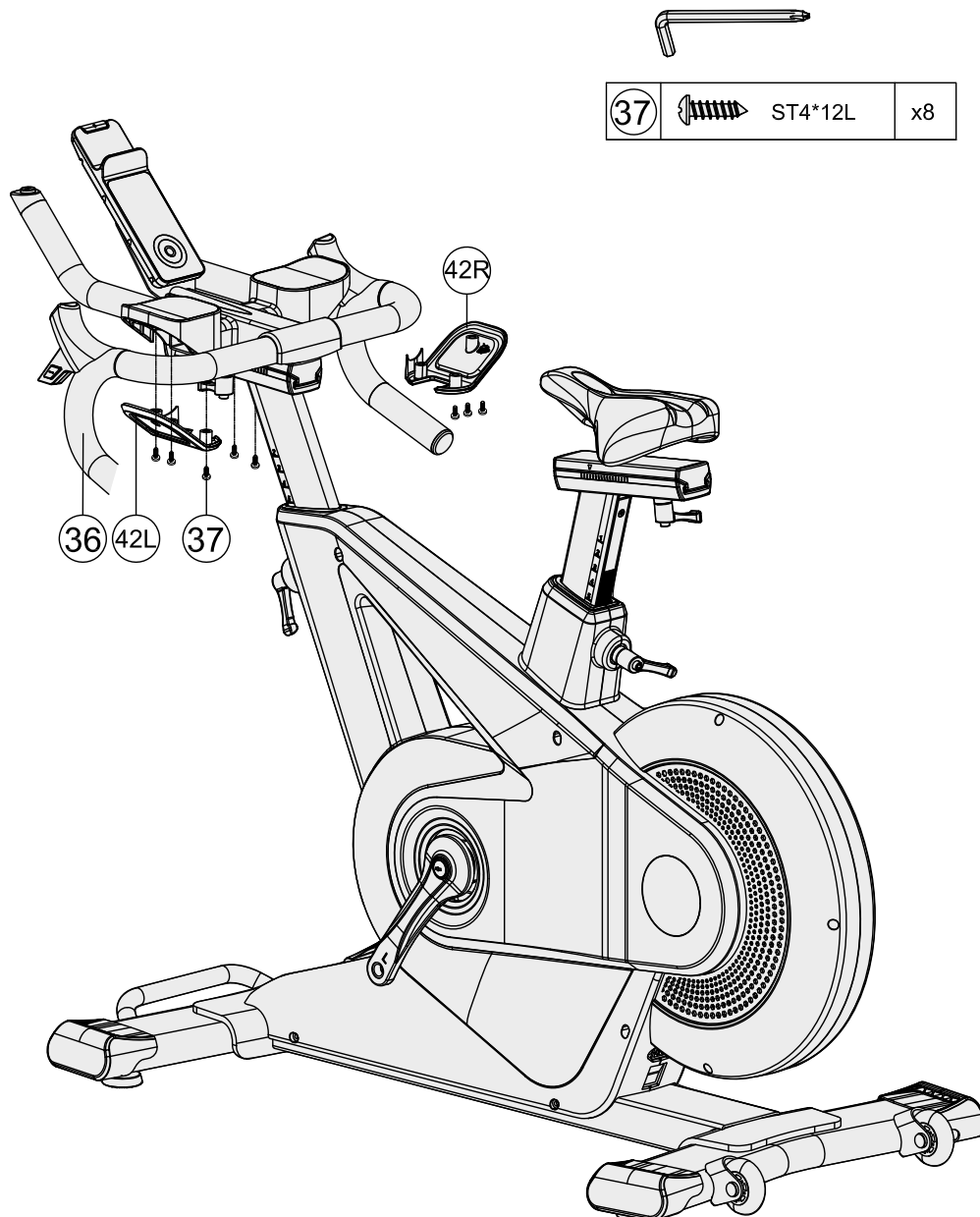

Step 7: Adjustment of the Seat

Height Adjustment

⚠ CAUTION

The seat post is marked with "STOP" for the minimum insertion depth. When adjusting, make sure not to exceed the minimum insertion depth.

1. Loosen and pull the L knob to adjust the height of the seat post.

⚠ CAUTION

In the following step, make sure the knob audibly engages in one of the adjustment holes.

2. Release the L knob.
3. Retighten the L knob.

Horizontal Adjustment

1. Loosen and pull the L knob underneath the seat until it can be moved forwards and backwards.
2. Move the seat into the desired position.

⚠ CAUTION

In the following step, make sure the knob audibly engages in one of the adjustment holes

3. Release the L knob.
4. Retighten the L knob.

Tilt Adjustment (A-3)

1. Loosen the bolt connection underneath the seat until the tilt can be adjusted.
2. Adjust the desired tilt.
3. Retighten the bolt connection.

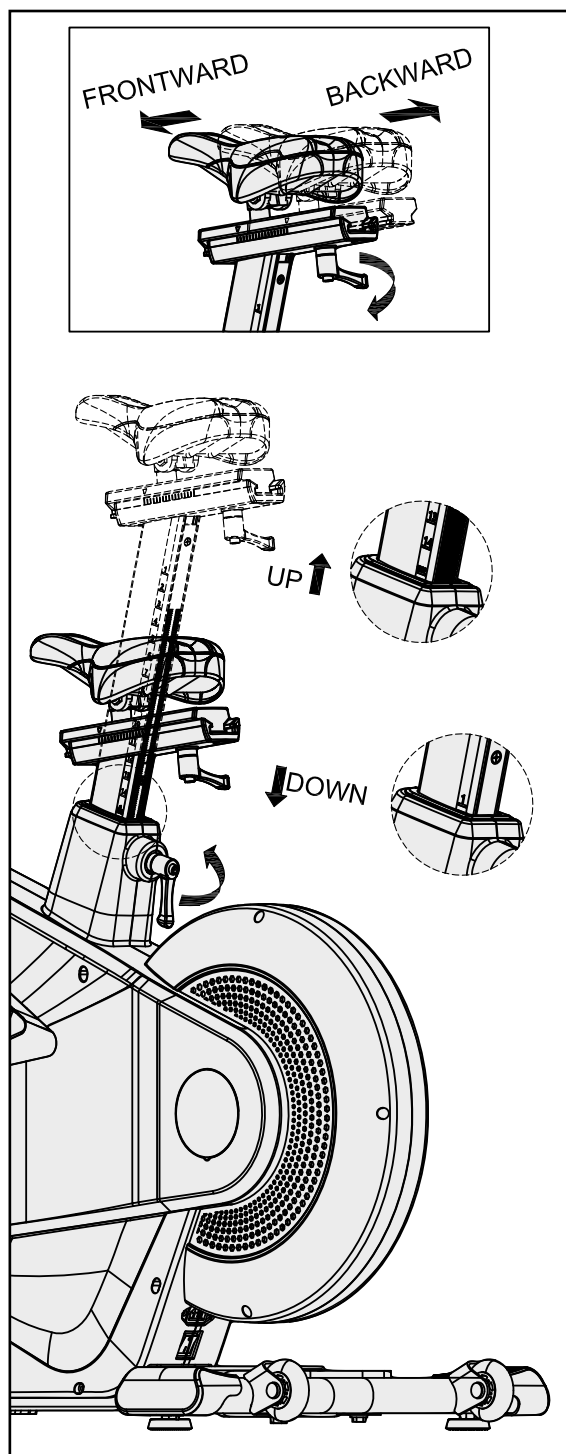

Step 8: Adjustment of the Handlebar

Height Adjustment

⚠ CAUTION

The front post is marked with "STOP" for the minimum insertion depth. When adjusting, make sure not to exceed the minimum insertion depth.

1. Loosen and pull the L knob to adjust the height of the front post.

⚠ CAUTION

In the following step, make sure the knob audibly engages in one of the adjustment holes.

2. Release the L knob.
3. Retighten the L knob.

Horizontal Adjustment

1. Turn the L knob to the left until the handlebar can be moved.
2. Adjust the handlebar into the desired position.
3. Retighten the L knob by turning it to the right.

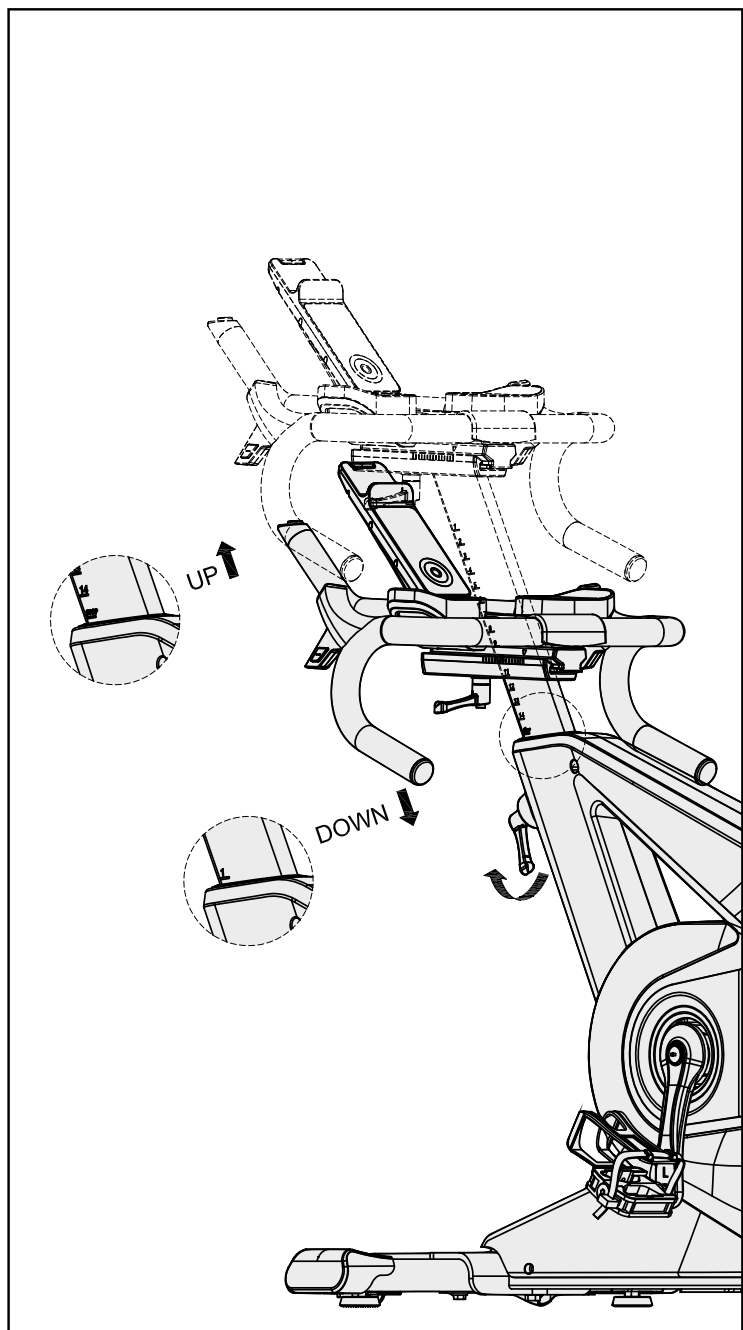
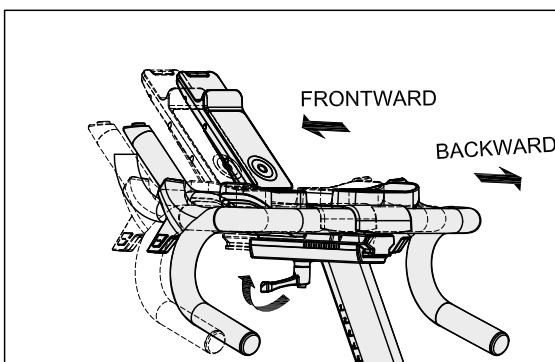

Step 9: Alignment of the Feet

If the floor is uneven, you can stabilize the equipment by turning the two setting screws under the stabilizers.

1. Lift the equipment on the desired side and rotate the setting screws under the stabilizer.
2. Rotate the screws clockwise in order to remove them and to raise the equipment.
3. Rotate them counterclockwise in order to lower the equipment.

Step 10: Connecting the Equipment to the Mains Supply

► **ATTENTION**

The equipment must not be connected to a multiple socket, otherwise it cannot be guaranteed that the equipment will be supplied with sufficient power. Technical errors can result.

Plug the power plug into a wall outlet that complies with the instructions in the chapter on electrical safety.

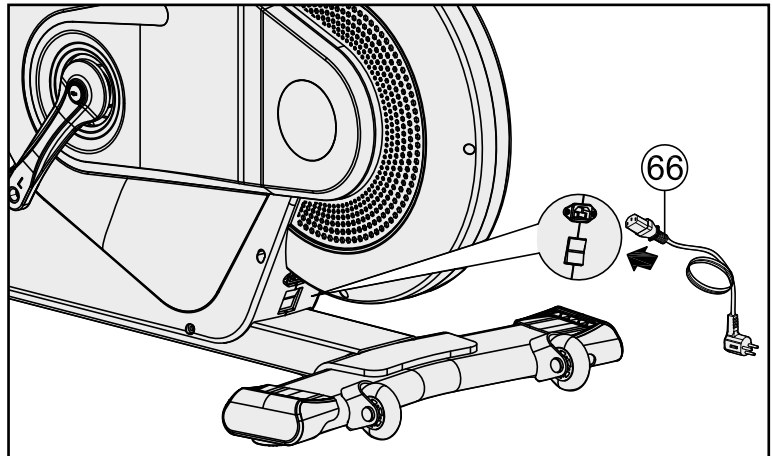

3 OPERATING INSTRUCTIONS

NOTICE

Familiarise yourself with all the functions and setting options of the device before starting training. Have the proper use of this product explained to you by a specialist.







3.1 Console Display



TIME	Display of the training time Display range 0:00 - 99:59 Setting range 0:00 - 99:00 (in 1:00 increments)
SPEED	Display of the speed Display range 0.0 - 99.9 km/h
DISTANCE	Display of the distance Display range 0 - 99.9 km or mi Setting range 0.0 - 99.0 km (in 1.0 increments)
CALORIES	Display of the calories Display range 0 - 999 kcal Setting range 0.0 - 990 kcal (in 10 increments)
PULSE	Display of the heart rate Display range 0 - 230 Setting range 0 - 230 (in 1 increments)

WATT	Display of the wattage Display range 0-999 Setting range 10 - 350 (in 5 increments)
RPM	Display of rotations per minute Display range 0 - 999
Resistance level 	Display of the resistance level The resistance level is displayed in colored segments (green, orange and red). Green - low; Red - high

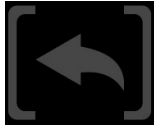
3.2 Button Functions

	START/PAUSE + With this button you start/pause the training
 (+)	UP + With the jog dial you increase the values by turning it clockwise
 (-)	DOWN + With the jog dial you decrease the values by turning it counterclockwise
	RECOVERY + With this button you start the recovery function
	RESET + To restart the console tap this button and hold it for about 2 seconds + In pause mode, tap this button to end the workout and return to the main menu
	ENTER + Use this button to confirm value settings

3.3 Turning on the Console and Standby Mode

1. Turn on the console.

① **NOTICE**

The power button is located on the main frame near the rear stabilizer

2. After the console is turned on, the LED display lights up for 2 seconds.

After that, the preset value for the wheel diameter is displayed for 1 second and the user profile setting is shown.

3. Select one of the four user profiles (U1~U4) and confirm with ENTER.

The console changes to the main menu

① **NOTICE**

If there is no signal input within 4 minutes, the console starts standby mode. To exit standby mode, tap any key or pedal.

3.4 Programmes

The console offers you a wide range of programmes. These include:

- + 4 target programmes
- + 12 preset programmes
- + 1 user defined programmes (per user profile)
- + 1 heart rate programme
- + 1 watt programme

In addition, the console has a quick start function and a recovery function.

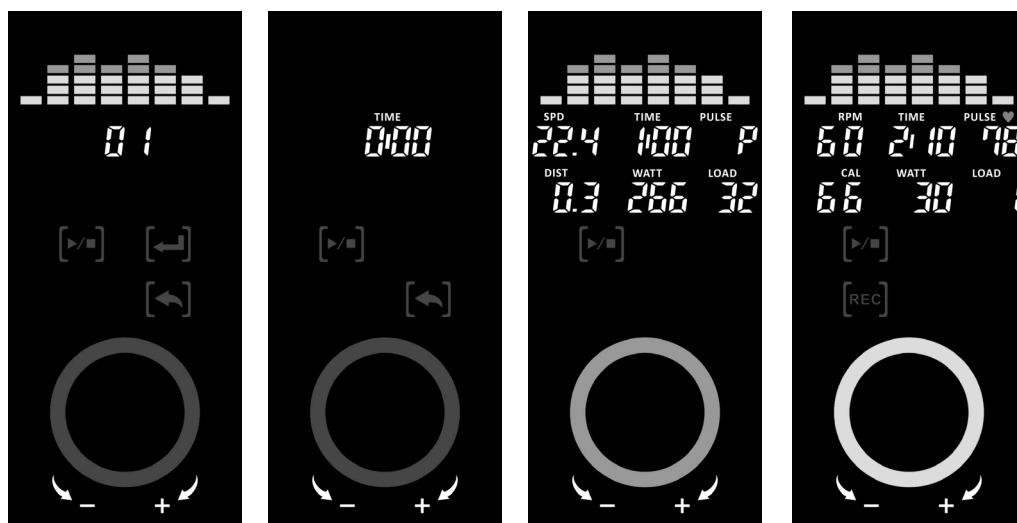

Example: Interface of the preset programme P1

3.4.1 Quick Start Function and Target Programmes (M)

Within this programme mode you can perform your training depending on single or multiple parameters. Alternatively, you can use the quick start function by simply tapping START or ENTER without making any settings.

① NOTICE

All the values you set will be counted down during the workout. Values that have not been set will be counted up.

1. Select the target programmes (M) in the main menu using the jog dial and confirm with ENTER.
2. Set the desired training time (TIME), distance (DIST), calories (CAL) and/or heart rate (PULSE) using the jog dial and confirm with ENTER.
3. Start the programme by tapping START/PAUSE.
4. To increase or decrease the resistance level, use the jog dial.
5. To pause the programme, tap START/PAUSE again.
6. To end the programme and return to the main menu, tap RESET.

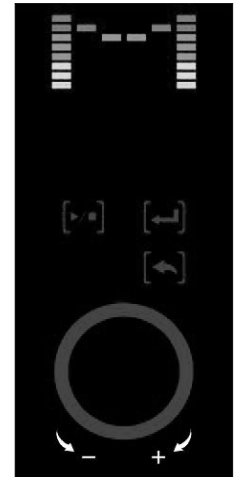

3.4.2 Preset Programmes (P)

There are 12 different preset programmes available.

1. Select the preset programmes (P) in the main menu using the jog dial and confirm with ENTER.
2. Choose one of the twelve preset programmes (P1 - P12) using the jog dial and confirm with ENTER.
3. Set the desired training time (TIME) using the jog dial and confirm with ENTER.
4. Start the programme by tapping START/PAUSE.
5. To increase or decrease the resistance level, use the jog dial.
6. To pause the programme, tap START/PAUSE again.
7. To end the programme and return to the main menu, tap RESET.

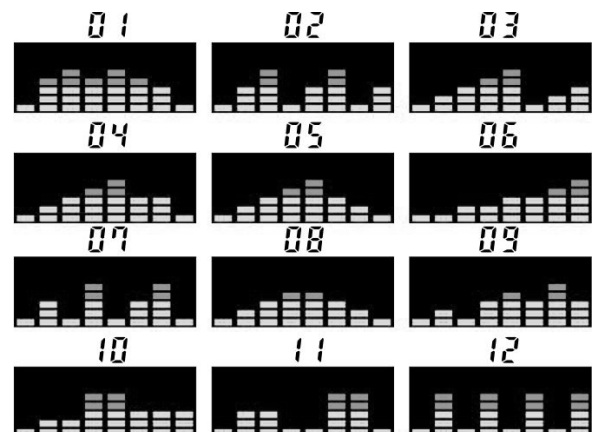
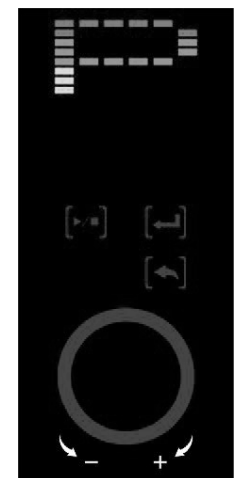

3.4.3 User Defined Programmes (U)

The console offers you the possibility to create your own user defined programme.

1. Select the user defined programme (U) in the main menu using the jog dial and confirm with ENTER.
2. Set the desired resistance level for the 8 segments with the jog dial and confirm with ENTER.
3. When you are happy with your programme settings, press and hold ENTER for 2 seconds.
4. Set the desired training time (TIME) using the jog dial and confirm with ENTER.
5. Start the programme by tapping START/PAUSE.
6. To increase or decrease the resistance level, use the jog dial.
7. To pause the programme, tap START/PAUSE again.
8. To end the programme and return to the main menu, tap RESET.

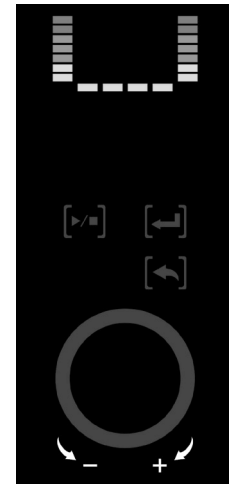

3.4.4 Heart Rate Controlled Programme (H)

This programme allows you to set a desired target heart rate and perform your workout in dependence.

⚠ WARNING

Your exercise equipment is not a medical device. The heart rate measurement of this device may be inaccurate. A variety of factors can affect the accuracy of the heart rate display. The heart rate display is intended only as a training aid.

ⓘ NOTICE

For this programme you must wear a compatible chest strap.

In the heart rate controlled programme, the resistance level is automatically adjusted depending on your current heart rate.

1. Select the heart rate controlled programme (H) in the main menu using the jog dial and confirm with ENTER.
2. Set the desired target heart rate (PULSE) using the jog dial and confirm with ENTER.
3. Set the desired training time (TIME) using the jog dial and confirm with ENTER.
4. Start the programme by tapping START/PAUSE.
5. To pause the programme, tap START/PAUSE again.
6. To end the programme and return to the main menu, tap RESET.

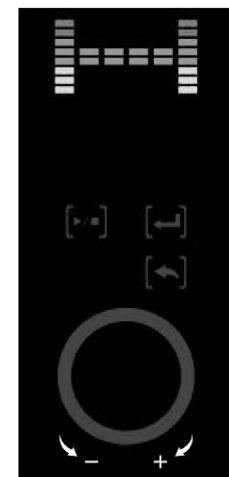

3.4.5 Watt Programme (W)

The console offers you the possibility to train depending on a wattage value you set, by adjusting the resistance level accordingly.

1. Select the watt programme (W) in the main menu using the jog dial and confirm with ENTER.
2. Set the desired watt value (WATT) using the jog dial and confirm with ENTER.
3. Set the desired training time (TIME) using the jog dial and confirm with ENTER.
4. Start the programme by tapping START/PAUSE.
5. To pause the programme, tap START/PAUSE again.
6. To end the programme and return to the main menu, tap RESET.

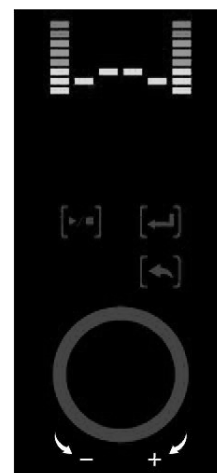

3.5 Recovery Function

ⓘ NOTICE

For this function you must wear a compatible chest strap.

1. After the workout, tap recovery (REC).

A countdown of 60 seconds is started

After the countdown has ended, your recovery heart frequency is displayed (F1 - F6).

F1 is the best possible result, F6 is the worst possible result.

2. To return to the main menu, tap REC again.

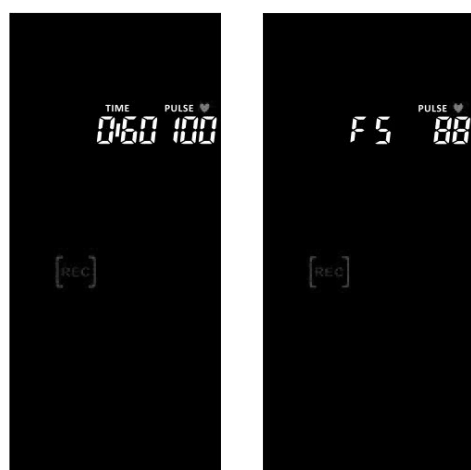

3.6 Compatibility Training Apps

This indoor cycle is equipped with a Bluetooth interface which allows you to connect the console to different training apps via your mobile device such as smartphone or tablet. You can find and download the training apps in the app stores of Google or Apple.

ⓘ NOTICE

- + Your mobile device must be compatible with the Bluetooth interface of the indoor cycle (Bluetooth 4.0).
- + Make sure that Bluetooth is activated on your mobile device and that the console is active. To activate the console, simply tap any button.
- + Third-party apps are produced and provided by external manufacturers. Changes and availability of these apps may occur and/or differ. Sport-Tiedje holds no responsibility for the availability, functionality or content of these apps.
- + Paid subscriptions may be required for the access and/or full functionality of the training apps.

Your fitness equipment is compatible with several training apps. These include:

- + Kinomap
- + iConsole+
- + ZWIFT

1. Make sure that Bluetooth is activated on your mobile device and the console of the indoor cycle is active.
2. Open the training app.
3. Select your fitness equipment. You can find the name on a small sticker on the back of the console.
4. Follow the instructions given in the app.

3.6.1 Connection with Kinomap

ⓘ NOTICE

- + Please note that a paid subscription is required for the full functionality of Kinomap.
- + Third party apps are produced and provided by external manufacturers. Changes and availability within these apps might occur. Sport-Tiedje does not take any responsibility and can not be held liable for the availability, functionality or contents of these apps.
- + Make sure Bluetooth is enabled on your mobile device and the console is active. Otherwise, simply tap any button.

1. Open Kinomap on your mobile device.
2. On the main screen, select "More" in the bar at the bottom.
3. Now select "Device management" on this page. Currently connected devices are displayed here.
4. To add a new device, tap the "+" at the top right.

NOTICE

There may be slight differences in menu navigation between Android and iOS operating systems.

- Now select the type of device. You can choose from roller trainer, exercise bike, treadmill, cross trainer, indoor cycle and rowing machine. For the Taurus Racer, select Indoor Cycle.
- On the next page you will see the different brands. Select "Taurus" and then the Taurus Racer.
- Now all Bluetooth sources in the surrounding area are displayed. Select a Bluetooth source that begins with i-Console The number that follows is also written on a small sticker on the back of the console.

The device is now added.

- Return to the main menu, select a track and enjoy a great track video.

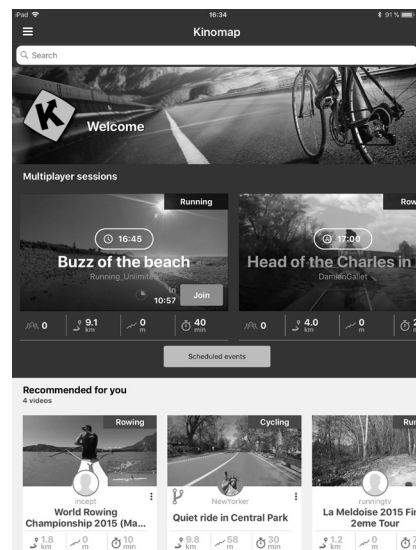
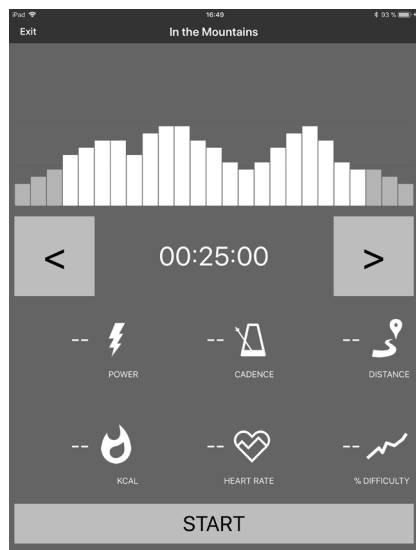

Example: Kinomap

4.1 General Instructions

⚠ WARNING

- + The storage location should be chosen so that improper use by third parties or children can be prevented.
- + If your equipment does not have transportation wheels, the equipment must be disassembled before transportation.

▶ ATTENTION

- + Make sure that the equipment is protected from moisture, dust and dirt in the selected storage location. The storage location should be dry and well ventilated and have a constant ambient temperature between 10°C and 35°C.

4.2 Transportation Wheels

▶ ATTENTION

If you want to transport your equipment over particularly sensitive and soft floor coverings, such as parquet, planks or laminate, lay out the transport route with cardboard or similar to avoid possible floor damage.

1. Stand behind the equipment and lift it until the weight is transferred to the transportation wheels. After that, you easily can move the equipment to a new position. For long transport distances the equipment should be disassembled and safely packed.
2. Select the new location by following the instructions in the section of this manual.

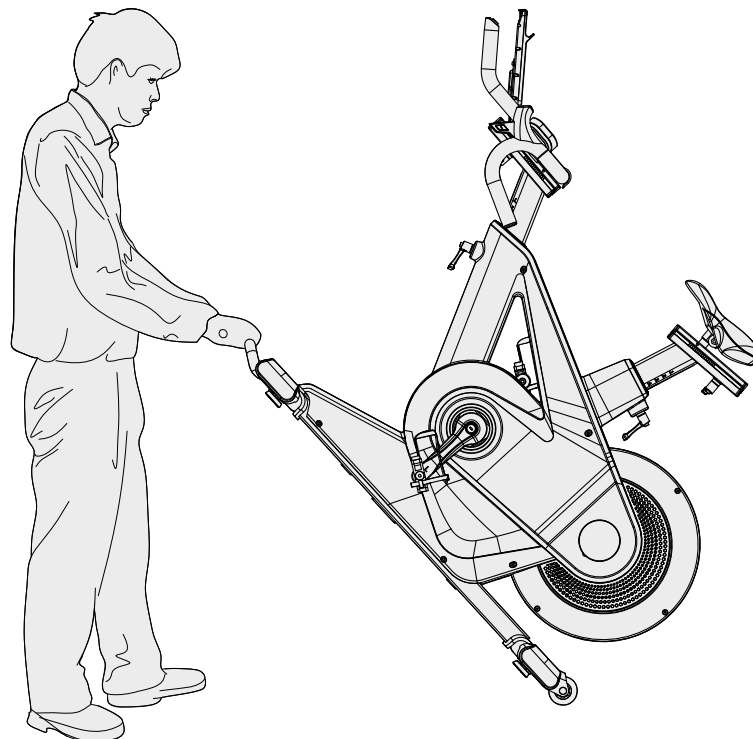

5.1 General Instructions

⚠ WARNING

- + Do not make any improper changes to the equipment.

⚠ CAUTION

- + Damaged or worn components may affect your safety and the life of the equipment. Safety can only be guaranteed if you check the equipment regularly for wear and damage. Immediately replace damaged or worn components. In such a case, contact the contract partner. The equipment must not be used until it has been repaired. If necessary, use only original spare parts.

▶ ATTENTION

- + In addition to the instructions and recommendations for maintenance and care given here, additional service and/or repair work may be necessary; this must only be carried out by authorised service technicians.

5.2 Faults and Fault Diagnosis

The equipment undergoes regular quality controls during production. Nevertheless, faults or malfunctions may occur. Frequently, individual parts are responsible for these disturbances, an exchange is usually sufficient. Please refer to the following overview for the most common errors and how to correct them. If the equipment still does not function properly, contact your contract partner.

Fault	Cause	Solution
Cracking in the pedal area	Pedals loose	Tighten the pedals
Equipment wobbles	Equipment is not level	Align the feet
Handlebar/saddle wobbles	Loose screws	Tighten screws firmly
Display is blank/is not working	Batteries empty or loose cable connection	Replace batteries or check cable connections
No pulse display	<ul style="list-style-type: none"> + Sources of interference in the room + Unsuitable chest strap + Wrong position of chest strap + Chest strap defective or battery empty + Pulse display defective 	<ul style="list-style-type: none"> + Eliminate sources of interference (e.g. mobile phone, WLAN, lawn mower and vacuum cleaner robot, etc. ...) + Use a suitable chest strap (see RECOMMENDED ACCESSORIES). + Reposition chest strap and/or moisten electrodes + Changing batteries

5.3 Error Codes and Troubleshooting

The electronics of the equipment continuously carries out tests. In case of deviations, an error code appears on the display and normal operation is stopped for your safety.

Please contact the contract partner for technical support.

5.4 Maintenance and Inspection Calendar

To avoid damage from body sweat, the equipment must be cleaned with a damp towel (no solvents!) after each training session.

The following routine tasks must be performed at the specified intervals:

Part	Weekly	Monthly
Display console	C	I
Plastic covers	C	I
Screws and cable connections		I
Check pedals for tightness		I
Legend: C = clean; I = inspect		

6 DISPOSAL

At the end of its operational life, this equipment cannot be disposed of in normal household waste. Instead, it must be disposed of via an electricals recycling centre. Further information can be obtained from your local authority's recycling service.

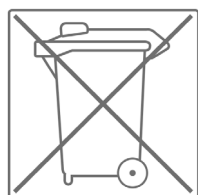

The materials can be recycled as per their symbols. Through the reuse, recycling of materials or other forms of recovery of old equipment, you make an important contribution to the protection of the environment.

7 RECOMMENDED ACCESSORIES

To make your training experience even more efficient and pleasant, we recommend that you add suiting accessories to your fitness equipment. For indoor cycles this could for example be a **floor mat**, which makes your fitness equipment stand more securely and also protects the floor from sweat or **silicone spray** to keep moving parts in good shape. For many indoor bikes it is possible to replace the **saddle** or **pedals**, as these are usually the same mounts used on bicycles.

If you have purchased a fitness machine with pulse training and want to train your heart rate, we strongly recommend that you use a compatible **chest strap**, as this ensures optimum transmission of the heart rate.

Our range of accessories offers the highest quality and makes training even better. If you would like to find out more about compatible accessories, please go to the detail page of the product in our webshop (the easiest way is to enter the article number in the search field above) and go to the recommended accessories on this page. Of course, you can also contact our customer service: by telephone, e-mail, in one of our branches or via our social media channels. We will be happy to advise you!



floor mat



chest strap



chest strap contact gel



pedals



silicone spray

8.1 Serial Number and Model Name

In order to provide you with the best possible service, please have the model name, article number, serial number, exploded drawing and parts list ready. The corresponding contact options can be found in chapter of this operating manual.

NOTICE

The serial number of your equipment is unique. It's located on a white sticker. The exact position of this sticker is shown in the following illustration.

Enter the serial number in the appropriate field.

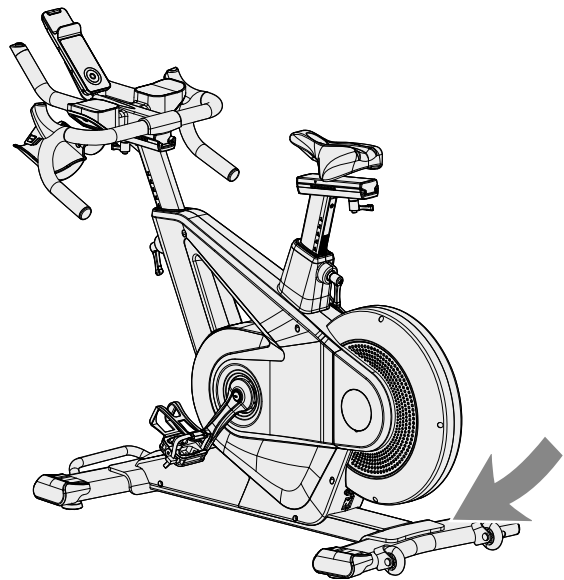

Serial number:

Brand / Category:

Model Name:

Article Number:

8.2 Parts List

No.	Name	Supplier Parts No.	Specification	Qty.
1	Main frame	849S0-3-1000-J3		1
2	Rear stabilizer	849S0-3-2112-J1		1
3	Adjustable wheel	76100-6-2174-B0	D50*M10*1.5	4
4	Front stabilizer	849S0-3-2100-J1		1
5	Oval Cap	849S0-6-2190-B0	125.5*54.6*88.6L	4
6	Allen boltM8*1.25*35L	50308-5-0035-F0	M8*1.25*35L	6
7	ScrewM8x1.25x20L	25600-6-3191-F0	M8x1.25x20L	8
9	Spring washer	55108-2-1520-FA	D15.4xD8.2x2T	6
10L	Back chain cover(left)	849S0-6-4512-B0	D474*52.7	1
10R	Back chain cover(right)	849S0-6-4513-B0	D474*55.2	1
11	Round cycle for chain cover(1)	849S0-6-4510-B0	96*46*9.2	1
12	Round cycle for chain cover(2)	849S0-6-4511-B0	89*50.2*9.2	1
13	Seat post	849S0-3-2200-AF1		1
14	Inner insert	849S0-6-1071-B0	21.5*80*200L	2
15	Inner insert(2)	849S0-6-1093-B0	20*80*200L	2
16	Flat washer	55108-1-1612-FA	D16*D8.5*1.2T	6
17	Front post	849S0-3-2000-AF1		1
18	L knob	52710-2-0020-RA	M10*20L	2
19	Cap(1)	849S0-6-2286-B0	55.7*29.4*18	4
20	Cap(2)	849S0-6-2287-B0	56.6*26.4*18	4
21	Bearing#6004-2RS	58006-6-1040-01	#6004-2RS(C0)	2
22	Waved washer	55120-5-2705-DA	D27*D20.3*0.5T	1
23	Handlebar adjustable tube	849S0-6-2018-AF2	56.3*30*210L	1
24	C-clip(D22.5*D18.5*1.2T)	55519-1-2312-DA	D22.5*D18.5*1.2T	2
25L	Chain cover supporting tube(left)	849S0-6-3111-J0	20*40*1.5T*50L	1
25R	Chain cover supporting tube(right)	849S0-6-3112-J0	38*38*1.5T*50L	1
26	Crank axle	849S0-6-2702-D1	D20*128L	1
27	Pulley	58008-6-1041-00	D300*25.5*2.8T	1

28	Allen nutM10*1.5*8T	55210-2-2008-FA	M10*1.5*8T	5
29	Round head screw	54010-5-0020-F0	M10*1.5*20L	5
30	Belt	58004-6-1127-00	560 PJ8	1
31	Round magnet	174R4-6-2574-00	M02	1
33	Brake handlebar	849S0-6-2083-00	80.3*54*21.4	2
34	Cover of brake	849S0-6-2084-B0	96.8*69.6*33	2
35	Positioning block	849S0-6-2082-B0	35.5*24*14.2	2
36	Handlebar	849S1-3-2400-B1		1
37	ScrewST4*1.41*12L	52804-2-0012-F0	ST4*1.41*12L	8
38	ScrewST4.2*15L	52842-2-0015-F0	ST4.2*15L	20
39	ScrewST4*1.41*13L,D10	54704-2-0013-F0	ST4*1.41*13L,D10	1
41	Elbow pad sleeve	849S0-6-3488-B0	109*84*6T	2
42L	Left handbar protective cover	849S0-6-3780-B0	116*94.4*61	1
42R	Right handbar protective cover	849S0-6-3782-B0	116*94.4*61	1
43	Handbar protective cover	849S0-6-3784-B0	338.2*238.5*68.8	1
44	Flat washer	55120-1-2615-NA	D26*D21*1.5T	1
45	Side cap	19000-6-4582-e70	D99*11	2
46L	Left chain cover	849S0-6-4501-B0	898*80.1*675.4	1
46R	Right chain cover	849S0-6-4502-B0	898*77.8*675.4	1
47	ScrewST4.2*1.4*10L	53342-2-0010-F0	ST4.2*1.4*10L	14
48L	Left crank	58007-6-1095-J0	170LxM20*1.5P	1
48R	Right crank	849S0-3-2704-J1		1
49	Anti-loosen nut	734S0-6-2775-N0	M10*1.25*9T	2
50	Bolt cover	734S0-6-2779-B0	D29*11.5L	2
51L&51R	Pedal set(L&R)	58029-6-1161-B3	"JD-004V M20*1.5P+SPD+basket"	1
52	ScrewM6*1.0P*16L	815S1-6-3191-F0	M6*1.0P*16L	4
53L	Fixed plate(L)	849S0-6-2427-J0	154*75*4T	1
53R	Fixed plate(R)	849S0-6-2428-J0	154*75*4T	1
54L	Bottle holder(L)	850A1-6-2091-B1	148*119.8*83.5*5T	1
54R	Bottle holder®	850A1-6-2092-B1	148*119.8*83.5*5T	1
55	EMS system	849S0-3-3102-00	D270*D30*50,12kg	1
56	Pin	71600-6-4586-60	D6*26.5*7.7	14

57	Switching mode power supplier	261D8-6-2411-00		1
58	Socket	26100-6-2413-00		1
59	Screw ST4*1.41*10L	51004-2-0010-F0	ST4*1.41*10L	2
60	Live wire	734S0-6-3480-00	150L	1
61	Neutral wire	734S0-6-3479-00	150L	1
62	Grounding cable	734S0-6-3486-00	200L	2
64	Middle computer cable	849S1-6-2587-00	550L	1
65	Lower computer cable	849S0-6-2573-02	300L	1
66	Adapter	26100-6-1775-02	1700L	1
67L	Button(-)	849S0-6-2534-RA1	31.7*21*10.5	1
67R	Button(+)	849S0-6-2533-RA1	31.7*21*10.5	1
68	controller	747S0-6-2597-01	EMS-7600	1
69	Saddle	58001-6-1424-B0	VL-4290	1
69A	Seat Lock	849S0-6-1074-F0	D22.2*M8	1
70	System external wire	821G0-6-3177-01	100L	1
71L	Button protective cover(L)	849S0-6-3672-B0	69.2*58*11.7	1
71R	Button protective cover(R)	849S0-6-3673-B0	69.2*58*11.2	1
72	Seat adjustable tube	849S0-3-4000-A40		1
73	Sensor cable	805S0-6-2576-00	500L	1
74	Power transmission line	849S0-6-2552-00	300L	1
75L	Trigger protective cover(L)	849S0-6-3674-B0	69.2*58*11.2	1
75R	Trigger protective cover(R)	849S0-6-3675-B0	69.2*58*11.7	1
76	ComputerSE8612-84	849S1-6-2501-B1	SE8612-84	1
77	C-clipS-17(1T)	55517-1-0010-00	S-17(1T)	1
78	Waved washerD17*D22*0.3T	55117-5-2203-DA	D17*D22*0.3T	3
79	Bearing6203-2RS	58006-6-1026-01	6203-2RS	2
80	Plastic flat washer	55110-1-2404-BF	D10*D24*0.4T	1
81	Allen bolt	50308-5-0030-C0	M8*1.25*30L	1
82	Flat washer	55108-1-2830-NA	D28*D8.5*3T	1
83	Handlebar plug	849S0-6-2475-F0	D35*15L	2
84	Spring	58003-6-1024-N0	D2.2*D14*65L	1
85	Fixing plate for idle wheel	744G0-3-1600-00		1

86	Plastic flat washer	55110-1-5010-BF	D50*D10*1.0T	1
87	Allen nutM8*1.25*6T	55208-2-2006-NA	M8*1.25*6T	1
88	Nylon nutM8*1.25*8T	55208-1-2008-NA	M8*1.25*8T	1
89	Handlebar grips(1)	849S0-6-2468-B1	D24*3.5T*270L	2
90	Handlebar grips(2)	849S0-6-2469-B1	D24*3.5T*530L	2
92L	Lower cable of quick key(1)	849S0-6-2544-01	650L	1
92R	Lower cable of quick key(2)	849S0-6-2536-01	650L	1
93L	Quick Keys Group 1	849S0-6-2540-B2	400L, Silver	1
93R	Quick Keys Group 2	849S0-6-2541-B2	400L, Silver	1
94	Bushing	58002-6-1099-00	D22.2*D8.2*7T	4
95	Fixed shaft	849S0-6-2371-N0	D8*31.5L*M4*0.7P	2
96	ScrewM4*0.7*12L	51404-2-0012-CU0	M4*0.7*12L	4
97	Flat washer	55105-1-1610-FA	D16*D5*1.0T	4
98	Screw trim cover group	849S0-3-2350-00	D19.5*D5*5T	4
99	Cushion	55306-4-0013-B9	D9*D5.8*13	5
100	Block	849S0-6-4073-00	23.5*10.6*25L	2
101	Round wheel	84302-6-2175-RA0	D70.5*23,pantone1795C	2
102	BoltM5*0.8*10L	52605-5-0010-F0	M5*0.8*10L	10
103	ScrewM6*1.0*10L	54006-5-0010-F0	M6*1.0*10L	4
104	Flat washer	55110-1-2520-FA	D25*D10*2.0T	2
105	BoltM5*0.8*12L	52605-2-0012-F0	M5*0.8*12L	2
106	Seat tube limit piece	849S0-6-2273-F0	486*19*2T	2
107	Countersunk small taper screws	51405-2-0010-F0	M5*0.8*10L	4
108	ScrewM5*0.8*10L	54805-2-0010-N0	M5*0.8*10L	2
109	Screw	54006-5-0020-F0	M6*1.0*20L	1
110	ScrewM6*1*12L	54806-2-0012-N0	M6*1*12L	6
111	Flat washer	55106-1-1310-NA	D13*D6.5*1.0T	2
112	ScrewM5*0.8*20L	54805-2-0020-N0	M5*0.8*20L	1
113	Allen nut	55205-2-2005-NA	M5*0.8*5T	1
114	Spring	58003-6-1081-N0	D1.2*D19.6*15.3L	2
115	Anchor Post	849S0-6-1172-F1	19.7*19.7*14.5L	2
116	Nut Cap	849S0-6-1171-F0	D30*12L*M24*2.0p	2

117	L knob	849S0-6-1072- RA0	M12*25L	2
118	Handle	849S0-6-5103-J2	D25.4*1.4T*373L	1
119	Cushion	849S0-6-1081-B0	194.3*107*1.2T	2
120	ScrewST2.3*8L	54723-2-0008-C0	ST2.3*8L	4
121	ScrewST2.3*12L	51023-2-0012-F0	ST2.3*12L	2
122	ScrewST2.9*13L	51029-2-0013- CU0	ST2.9*13L	4
136	Knurled hand screw	26100-6-1079-00	D31*16	2
137	External teeth lock gasket	55105-6-1006-FA	D10*D5.3*0.6T	2
138	ScrewM5*0.8*35L	50805-2-0035-N0	M5*0.8*35L	1
	Allen cross wrentch	58030-6-1031-N1	M6	1
	Open-end wrentch	58030-6-1050-C0	153*6.5T	1

8.3 Exploded Drawing

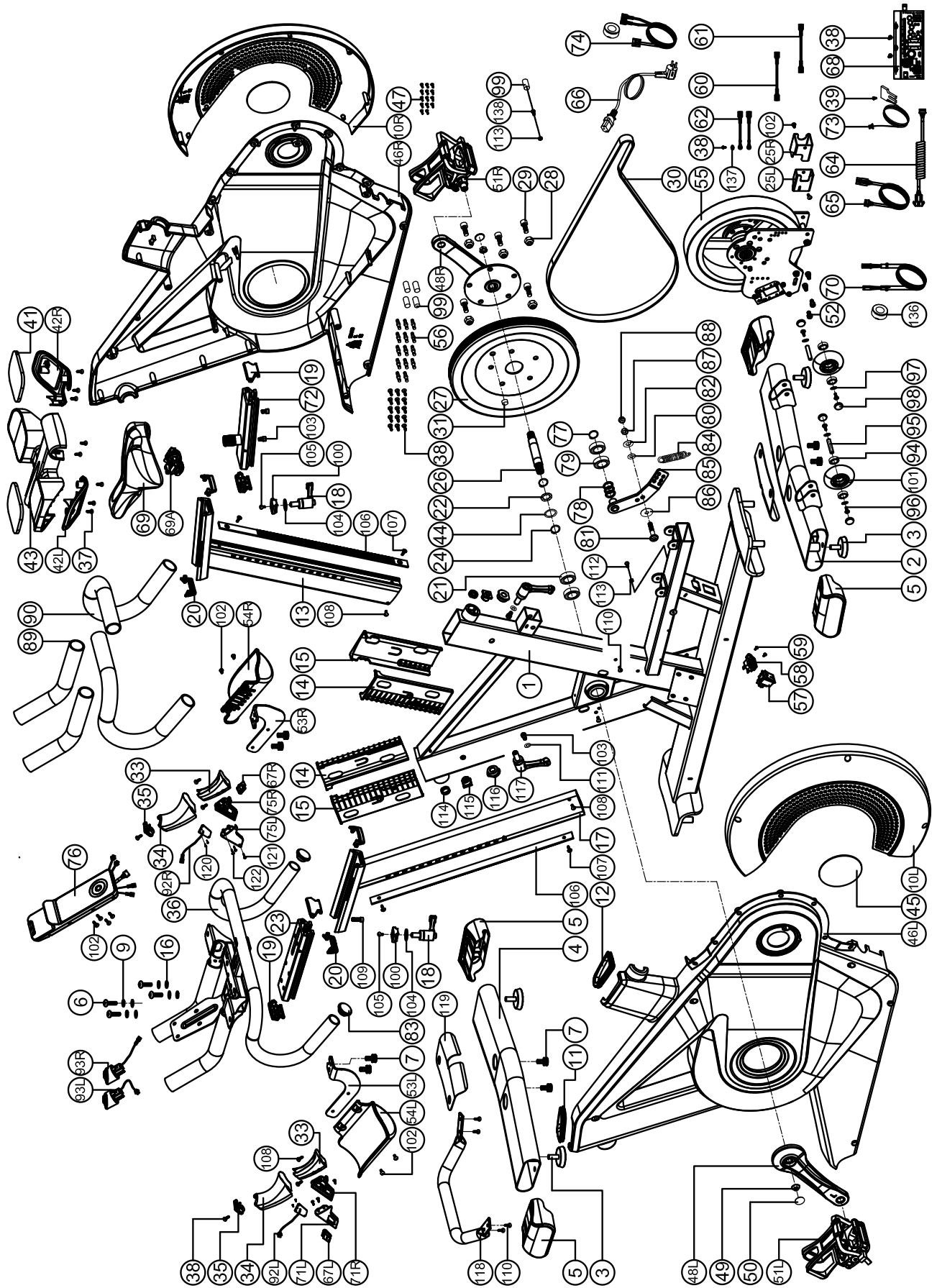

Training equipment from Taurus® is subject to strict quality control. However, if a fitness equipment purchased from us does not work perfectly, we take it very seriously and ask you to contact our customer service as indicated. We are happy to help you by phone via our service hotline.

Error Descriptions

Your fitness equipment is developed for long-term, high-quality training. However, should a problem arise, please first read the operating instructions. For further assistance, please contact your contract partner or call our service hotline. To ensure your problem is solved as quickly as possible, please describe the defect as exactly as possible.

In addition to the statutory warranty, we provide a warranty for every fitness equipment purchased from us according to the following provisions.

Your statutory rights are not affected.

Warranty

The warranty is the first/original buyer and/or any person who received a newly purchased product as a gift from the original buyer.

Warranty period

The warranty periods, shown on our web shop, begin on delivery of the fitness equipment. The respective warranty periods for your equipment can be found on its product website.

Repair Costs

According to our choice, there will either be a repair, a replacement of individual damaged parts or a complete replacement. Spare parts, that have to be mounted while assembling the equipment, have to be replaced by the warranty holder personally and are not a part of repair. After the expiration of the warranty period, the responsibility for parts costs, repair costs, installation costs and delivery costs lies with the warranty holder.

The terms of use are defined as follows:

- + Home use: solely for private use in private households up to 3 hours per day
- + Semi-professional use: up to 6 hours per day (e. g. rehabilitation centres, hotels, clubs, company gyms)
- + Professional use: more than 6 hours per day (e. g. commercial gyms)

Warranty Service

Within the warranty period, equipment which develops faults as a result of material or manufacturing defects, will be repaired or replaced at our discretion. Ownership of equipment or parts of equipment which have been replaced is transferred to us. The warranty period is not extended nor does a new warranty period begin following repair or replacement under the warranty.

Warranty Conditions

For the warranty to be valid, the following steps must be taken:

Please contact our customer service by email or phone. If the product under warranty has to be sent in for repair, the seller bears costs. After expiry of the warranty, the buyer bears the costs of transport and insurance. If the fault is covered by our warranty, you will receive a new or repaired equipment in return.

Warranty claims are invalid in case of damage resulting from:

- + misuse or improper handling
- + environmental influences (moisture, heat, electrical surge, dust, etc.)
- + failure to follow the current safety measures for the equipment
- + failure to follow the operating instructions
- + use of force (e. g. hitting, kicking, falling)
- + interventions which were not carried out by one of our authorized service centres
- + unauthorised repair attempts

Proof of Purchase and Serial Number

Please make sure that you are able to provide the appropriate receipt when claiming on your warranty. So that we can clearly identify the model of your equipment, and for the purposes of our quality control, you will need to give the serial number of your equipment, when contacting the service team. Where possible please have your serial number and your customer number ready when you call our service hotline. It will help us to deal with your request swiftly.

If you cannot find the serial number on your fitness equipment, our service team is at your disposal to offer further information.

Service outside of the Warranty Period

We are also happy to issue an individual cost estimate if there is a problem with your fitness equipment after the warranty has expired, or in cases which do not fall under the terms of the warranty, e. g. normal wear and tear. Please contact our customer service team to find a quick and cost-effective solution to your problem. In such a case you will be responsible for the delivery costs.

Communication

Many problems can be solved just by speaking to us as your specialist supplier. We know how important it is to you as a user of the fitness equipment to have problems solved quickly and simply, so you can enjoy working out with minimal interruption. For that reason, we also want to resolve your queries quickly and in a straightforward manner. Thus, please always keep your customer number and the serial number of the faulty equipment handy.

10 CONTACT

DE	DK	FR
<p>TECHNIK</p> <p>☎ +49 4621 4210-900 ☎ +49 4621 4210-698 ✉ technik@sport-tiedje.de 🕒 Öffnungszeiten entnehmen Sie unserer Homepage.</p> <p>SERVICE</p> <p>☎ 0800 20 20277 (kostenlos) ☎ 04621 4210 - 0 ✉ info@sport-tiedje.de 🕒 Öffnungszeiten entnehmen Sie unserer Homepage.</p>	<p>TEKNIK OG SERVICE</p> <p>☎ 80 90 16 50 +49 4621 4210-945 ✉ info@fitshop.dk 🕒 Åbningstider kan findes på hjemmesiden.</p>	<p>TECHNIQUE & SERVICE</p> <p>☎ +33 (0) 189 530984 +49 4621 42 10 933 ✉ info@fitshop.fr 🕒 Vous trouverez les heures d'ouverture sur notre site Internet.</p>
	PL	BE
	<p>DZIAŁ TECHNICZNY I SERWIS</p> <p>☎ 22 307 43 21 +49 4621 42 10-948 ✉ info@fitshop.pl 🕒 Godziny otwarcia można znaleźć na stronie głównej.</p>	<p>TECHNIQUE & SERVICE</p> <p>☎ 02 732 46 77 +49 4621 4210 933 ✉ info@fitshop.be 🕒 Vous trouverez les heures d'ouverture sur notre site Internet.</p>
UK	NL	INT
<p>CUSTOMER SUPPORT</p> <p>☎ 00800 2020 2772 +494621 4210 944 ✉ info@sport-tiedje.co.uk 🕒 You can find the opening hours on our homepage.</p>	<p>TECHNISCHE DIENST & SERVICE</p> <p>☎ +31 172 619961 ✉ service@fitshop.nl 🕒 De openingstijden vindt u op onze homepage.</p>	<p>TECHNICAL SUPPORT & SERVICE</p> <p>☎ +49 4621 4210-944 ✉ service-int@sport-tiedje.de 🕒 You can find the opening hours on our homepage.</p>
ES	AT	CH
<p>TECNOLOGÍA Y SERVICIOS</p> <p>☎ 911 238 029 ✉ info@fitshop.es 🕒 Consulta nuestro horario de apertura en la página web.</p>	<p>TECHNIK & SERVICE</p> <p>☎ 0800 20 20277 (Freecall) +49 4621 42 10-0 ✉ info@sport-tiedje.at 🕒 Öffnungszeiten entnehmen Sie unserer Homepage.</p>	<p>TECHNIK & SERVICE</p> <p>☎ 0800 202 027 +49 4621 42 10-0 ✉ info@fitshop.ch 🕒 Öffnungszeiten entnehmen Sie unserer Homepage.</p>

Please find a detailed overview including address and opening hours for all stores of the Sport-Tiedje Group in Germany and abroad on the following website:

www.sport-tiedje.com/en/stores

WE LIVE FITNESS

WEBSHOP AND SOCIAL MEDIA

Sport-Tiedje is Europe's largest specialist store for home fitness equipment with currently over 70 stores and one of the world's most renowned online mail order companies for fitness equipment. Private customers order via the 25 web shops in the respective national language or have their desired equipment assembled on site. In addition, the company supplies fitness studios, hotels, sports clubs, companies and physio practices with professional equipment for endurance and strength training.

Sport-Tiedje offers a wide range of fitness equipment from renowned manufacturers, high-quality in-house developments and comprehensive services, such as a build-up service and sports scientific advice before and after the purchase. The company employs numerous sports scientists, fitness trainers and competitive athletes.

Visit us also on our social media platforms or our blog!



www.sport-tiedje.co.uk
www.sport-tiedje.de/blog



www.facebook.com/SportTiedje



www.instagram.com/sporttiedje



www.youtube.com/user/sporttiedje

TAURUS

 cardiostrong 

BODYCRAFT

 cardio**jump**

 **DUKEFITNESS**

DARWIN

Notes

Notes

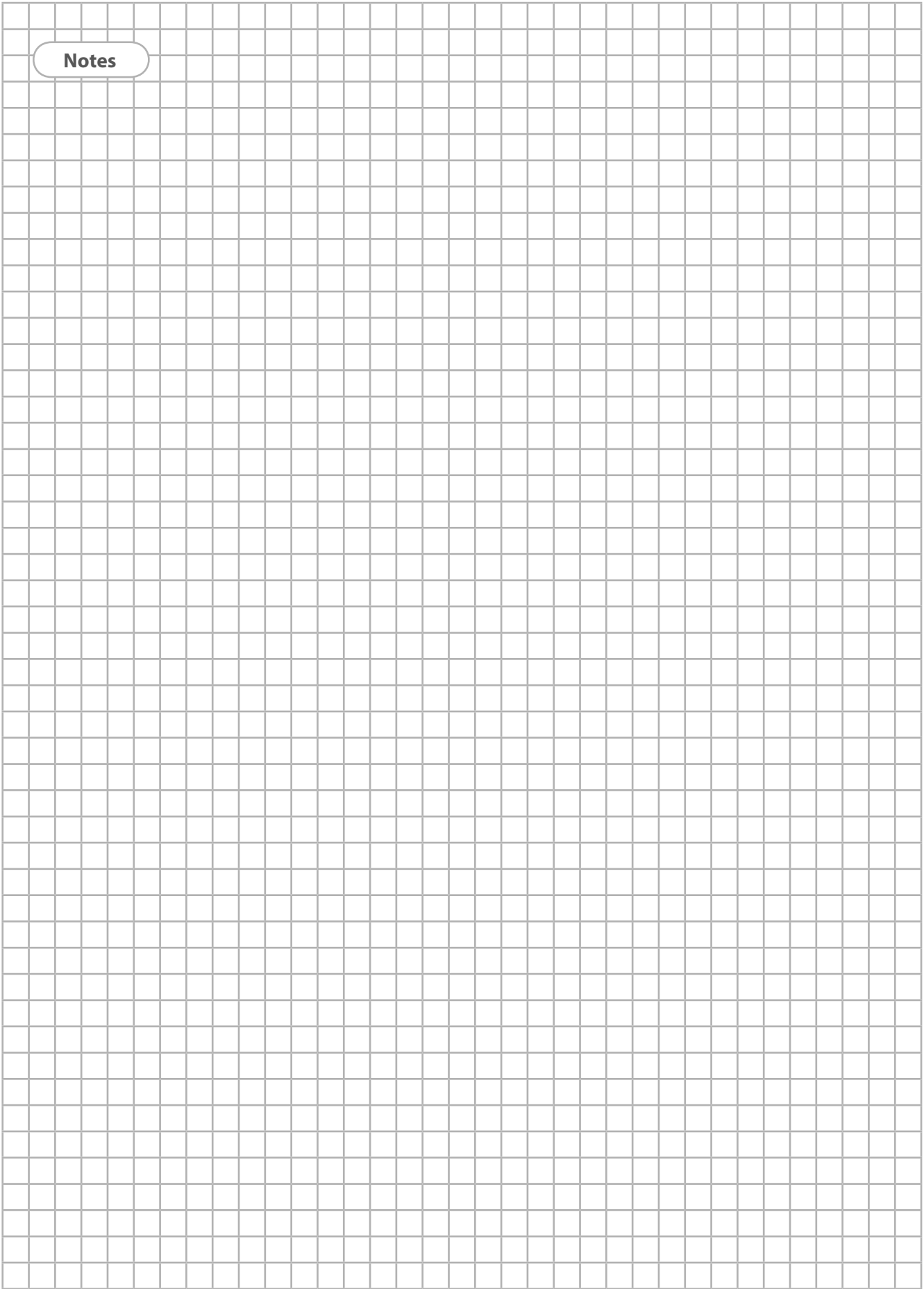

Notes

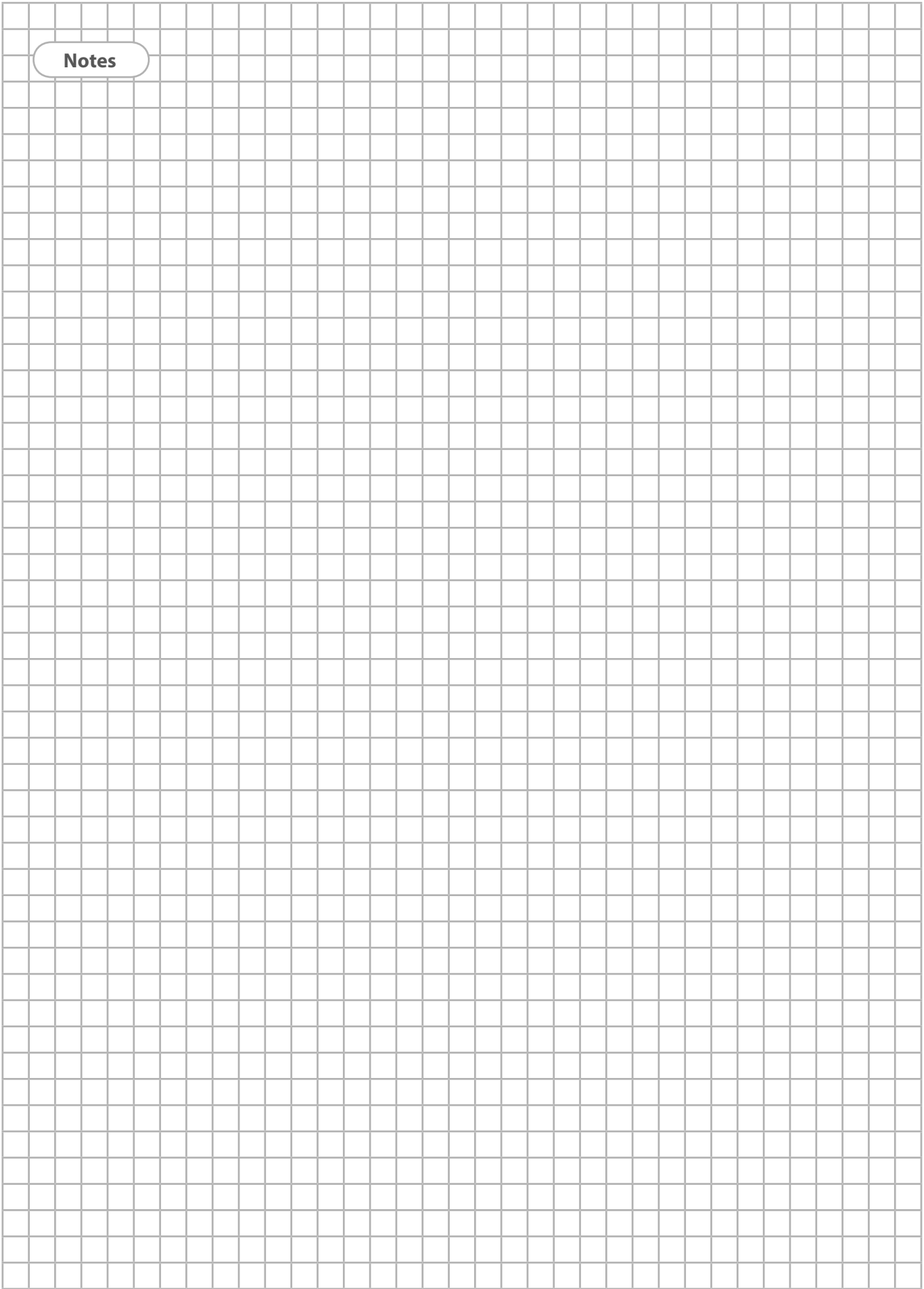

Notes

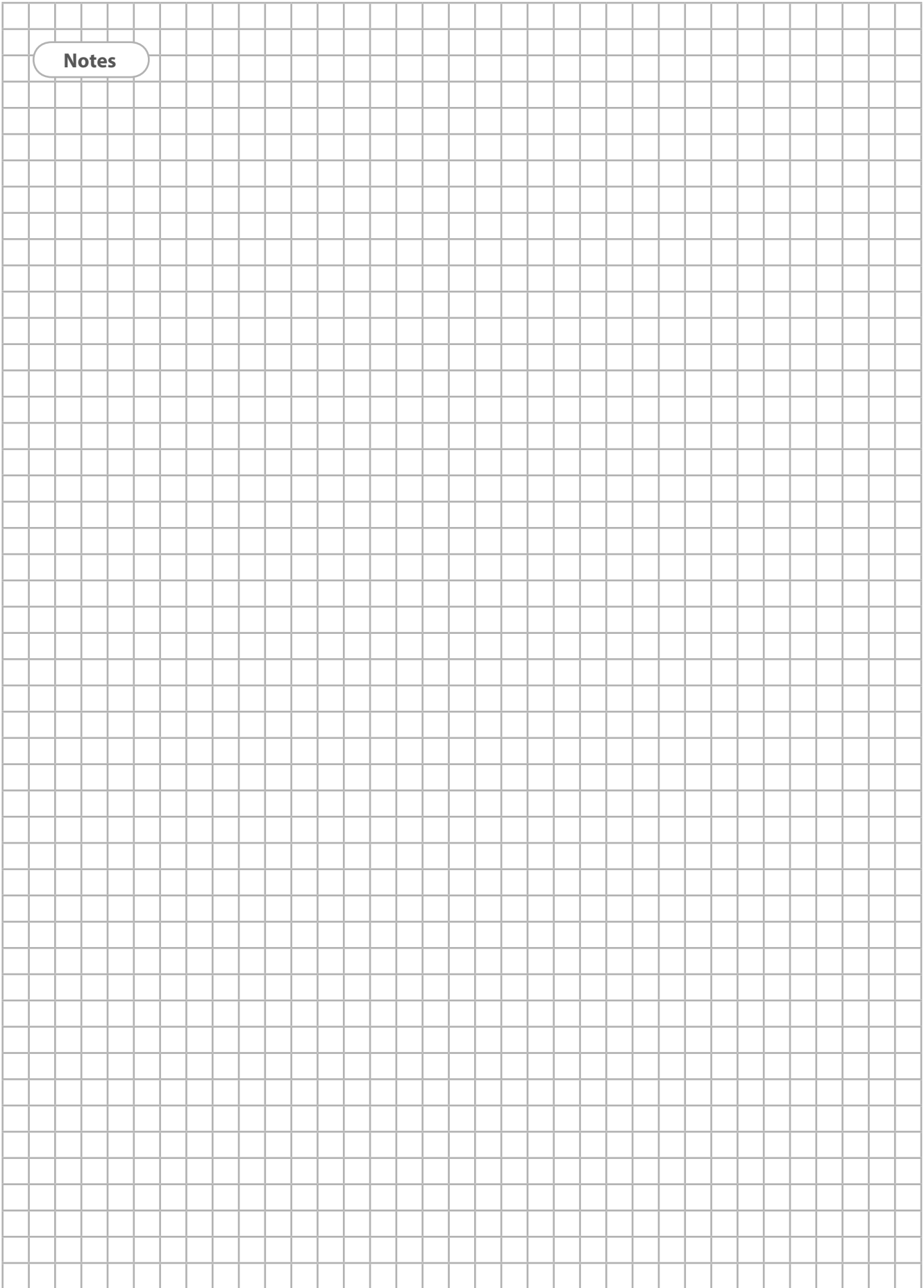

TAURUS[®]

Taurus Racer Pro