

TAURUS®

Assembly and Operating Instructions

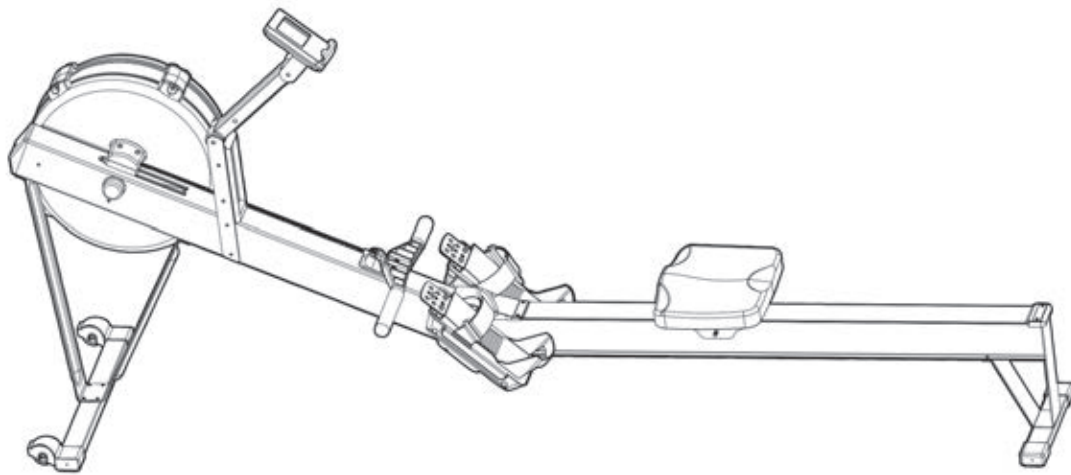

max. 150 kg



~10-15 Min.



34 kg
L 142 | W 61 | H 102

CVRM2550.01.01

SKU Code: CVRM2550

Taurus Elite Rower

Content

1	GENERAL INFORMATION	7
1.1	Technical Data	7
1.2	Personal Safety	8
1.3	Set-Up Place	9
2	ASSEMBLY	10
2.1	General Instructions	10
2.2	Scope of Delivery	11
2.3	Assembly	12
2.4	Adjustments	14
3	OPERATING INSTRUCTIONS	15
3.1	Console Display	15
3.2	Key Functions	16
3.3	Operation Instructions	17
3.4	Notes on Correct Rowing	27
4	STORAGE AND TRANSPORT	30
4.1	General Instructions	30
4.2	Transportation Wheels	30
5	TROUBLESHOOTING, CARE AND MAINTENANCE	31
5.1	General Instructions	31
5.2	Faults and Fault Diagnosis	31
5.3	Maintenance and Inspection Calendar	32
6	DISPOSAL	32
7	RECOMMENDED ACCESSORIES	33
8	ORDERING SPARE PARTS	34
8.1	Serial Number and Model Name	34
8.2	Parts List	35
8.3	Exploded Drawing	36

Dear customer,

Thank you for choosing a high-quality equipment of the brand Taurus®. Taurus® offers sports and fitness equipment for the sophisticated home sport and the equipment of fitness studios and business customers. With Taurus® fitness equipment, the focus is on what sport is all about: maximum performance! Therefore, the equipment is developed in close consultation with athletes and sports scientists. Because athletes know best what makes perfect fitness equipment.

Further information can be found at www.sport-tiedje.com.

Intended Use

The equipment may only be used for its intended purpose.

This fitness equipment is suitable for home use, semi-professional use and commercial or professional use. The semi-professional sector includes, for example, institutional facilities such as hospitals, schools, hotels and associations. Professional use refers to commercial use, e.g. in a fitness studio.

Legal Notice

Sport-Tiedje GmbH
Europe's No. 1 for home fitness

International Headquarters
Flensburger Straße 55
24837 Schleswig
Germany

Management:
Christian Grau
Sebastian Campmann
Dr. Bernhard Schenkel
No. HRB 1000 SL
Local Court Flensburg
European VAT Number: DE813211547

Disclaimer



©2011 Taurus® is a registered brand of the company SportTiedje GmbH. All rights reserved. Any use of this trademark without the explicit written permission of Sport-Tiedje is prohibited.

Product and manual are subject to change. Technical data can be changed without advance notice.

ABOUT THIS MANUAL

Please carefully read the entire manual before installation and first use. The manual will help you to quickly set up the system and explains how to safely use it. Make sure that all persons exercising with the equipment (especially children and persons with physical, sensory, mental or motor disabilities) are informed about this manual and its contents in advance. In case of doubt, responsible persons must supervise the use of the equipment.



Due to ongoing changes and software optimisations, the manual may have to be updated. If you notice any discrepancies during assembly or use, please refer to the manual uploaded to the webshop. The latest manual is always available there.

This equipment has been manufactured according to the latest safety knowledge. As far as possible, potential safety hazards which could cause injury have been eliminated. Make sure to carefully follow the instructions and that all parts are securely in place. If required, read through the instructions again to correct any mistakes.

Please pay close attention to the safety and maintenance instructions given here. The contract partner cannot be held liable for damage to health, accidents or damage to the equipment when it is not used in accordance with these instructions.

The following safety instructions may appear in this manual:

► **ATTENTION**

This notice indicates potentially hazardous situations which, if not avoided, may result in property damage.

⚠ **CAUTION**

This notice indicates potentially hazardous situations which, if not avoided, may result in slight or minor injuries!

⚠ **WARNING**

This notice indicates potentially hazardous situations which, if not avoided, may result in death or serious injuries!

⚠ **DANGER**

This notice indicates potentially hazardous situations which, if not avoided, will result in death or serious injuries!

ⓘ **NOTICE**

This notice indicates further useful information.

Retain these instructions in a safe place for future reference, maintenance or when ordering replacement parts.

1.1 Technical Data

LCD display of

- + strokes, strokes per minute
- + training time in min
- + distance in m
- + time/500 m: average / current
- + calorie consumption in kcal
- + heart rate (when using a chest strap)
- + Watt

Resistance system: air resistance

Total number of training programs: 9

Weight and dimensions:

Article weight (gross, including packaging): 39.0 kg

Article weight (net, without packaging): 33.3 kg

Packaging dimensions (L x W x H): approx. 142 cm x 40 cm x 55 cm

Set-up dimensions (L x W x H): approx. 242 cm x 61 cm x 102 cm

User weight: 150 kg

1.2 Personal Safety

DANGER

- + Before you start using the equipment, you should consult your physician that this type of exercise is suitable for you from a health perspective. Particularly affected are persons who: have a hereditary disposition to high blood pressure or heart disease, are over the age of 45, smoke, have high cholesterol values, are overweight and/or have not exercised regularly in the past year. If you are under medical treatment that affects your heart rate, medical advice is absolutely essential.
- + Note that excessive training can seriously endanger your health. Please also note that heart rate monitoring systems can be inaccurate. If you notice any signs of weakness, nausea, dizziness, pain, shortness of breath, or other abnormal symptoms, stop exercising immediately and seek advice from your doctor if necessary.

WARNING

- + This equipment may not be used by children under the age of 14.
- + Children should not be allowed unsupervised access to the equipment.
- + Persons with disabilities must have a medical license and must be under strict observation when using the equipment.
- + The equipment is strictly for use by one person at a time.
- + If your equipment provides a safety key, the clip of the safety key must be attached to your clothing before starting your training. In the event of a fall, the EMERGENCY STOP of the equipment can be initiated.
- + Keep your hands, feet and other body parts, hair, clothing, jewellery and other objects well clear of moving parts.
- + During use, wear suitable sports clothing rather than loose or baggy clothing. When wearing sports shoes, make sure they have suitable soles, preferably made of rubber or other non-slip materials. Shoes with heels, leather soles, studs or spikes are unsuitable. Never exercise barefoot.

CAUTION

- + If your equipment needs to be connected to the power supply with a mains cable, make sure that the cable is not a potential tripping hazard.
- + Make sure that nobody is within the range of motion of the equipment during training so as not to endanger you or other persons.

ATTENTION

- + Do not insert any objects of any kind into the openings of the device.

1.3 Set-Up Place

⚠ WARNING

- + Do not place the equipment in main corridors or escape routes.

⚠ CAUTION

- + Choose a location in which to place the equipment such that there is enough free space/ clearance to the front, the rear and to the sides of the equipment. Make sure that you leave at least 30 cm on each side of the equipment and at least 15 cm in front of and behind the equipment as a training zone. This is the minimum required area in order to safely use the equipment. The recommended free zone around the equipment should be at least 60 cm on each side and 45 cm in front of and behind the equipment.
- + The training room should be well ventilated during training and not be exposed to any draughts.
- + Choose the place in which to set up the equipment such that there is enough free space/ clearance to the front, the rear and to the sides of the equipment.
- + The set-up and mounting surface of the equipment should be flat, loadable and solid.

▶ ATTENTION

- + The device may only be used in one building, in sufficiently tempered and dry rooms (ambient temperatures between 10°C and 35°C). The equipment should not be used outdoors or in rooms with high humidity (over 70%) like swimming pools.
- + A floor protective mat/equipment underlay can help to protect high-quality floor coverings (parquet, laminate, cork, carpets) from dents and sweat and can help to level out slight unevenness.

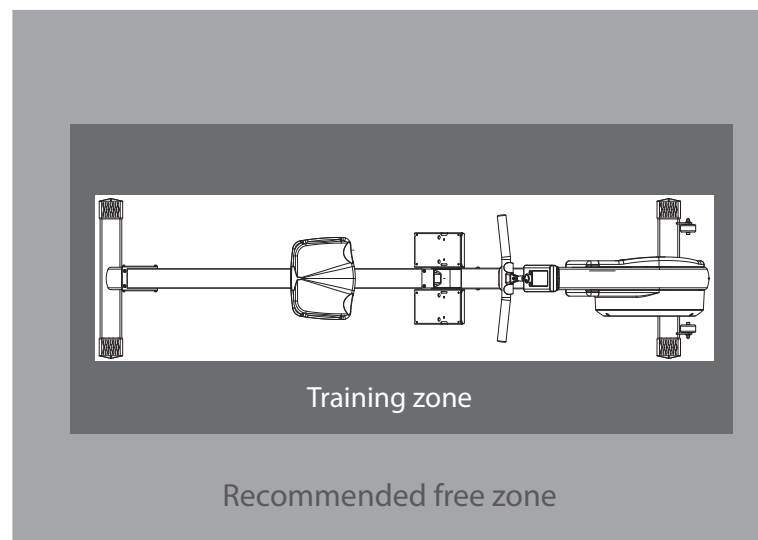

2.1 General Instructions

DANGER

- + Do not leave any tools, packaging materials such as foils or small parts lying around, as otherwise there is a danger of suffocation for children. Keep children away from the equipment during assembly.

WARNING

- + Pay attention to the instructions attached to the equipment in order to reduce the risk of injuries.

CAUTION

- + Do not open the packaging when it is lying on its side.
- + Ensure to have sufficient room for movement in each direction during assembly.
- + The assembly of the equipment must be carried out by at least two adults. If in doubt, seek the help of another technically skilled person.

ATTENTION

- + To prevent damage to the equipment and the floor, assemble the equipment on a mat or packaging board.

NOTICE

- + In order to make the assembly as simple as possible, some screws and nuts to be used can already be pre-assembled.
- + Ideally, assemble the equipment at its later set-up place.



2.2 Scope of Delivery

The scope of delivery consist of the following parts. At the beginning, check whether all parts and tools belonging to the device are included in the scope of delivery and whether damage has occurred. In the event of complaints, the contractual partner must be contacted directly.



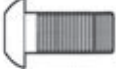

CAUTION

If parts of the scope of delivery are missing or damaged, the assembly must not be carried out.

Package contents

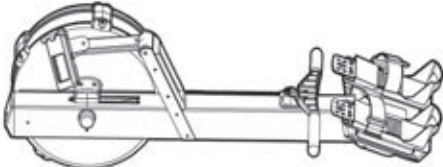
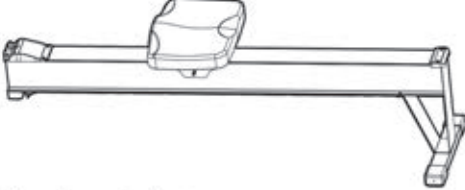
<p>No.92</p>  <p>Flat Head Hex Socket Bolt (M6x15) x 4pcs</p>	<p>No.93</p>  <p>Flat Head Hex Socket Bolt (M6x12) x 4pcs</p>
---	---

Components

<p>No.1</p>  <p>Main Frame x 1pc</p>		<p>No.11</p>  <p>Aluminum Rail x 1pc</p>
<p>No.2</p>  <p>Front Stabilizer x 1pc</p>	<p>No.3</p>  <p>Leg Front (Long) x 1pc</p>	<p>No.4</p>  <p>Leg Front (Short) x 1pc</p>

Tools

No. 125

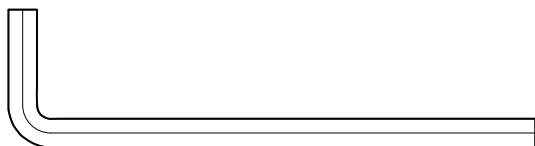

Allen Wrench (S4) x 1pc

2.3 Assembly

Before assembly, take a close look at the individual assembly steps shown and carry out the assembly in the order given.

① NOTICE

First loosely screw all parts together and check that they fit properly. Then tighten the screws using the tool only when you are instructed to do so.

Step 1:

1. Attach the Leg Front Long (3) and Leg Front Short (4) to the Front Stabilizer (2) with 4pcs Flat Head Hex Socket Screw (92).
2. Notice that the Leg Front Long (3) is under the Leg Front Short (4).

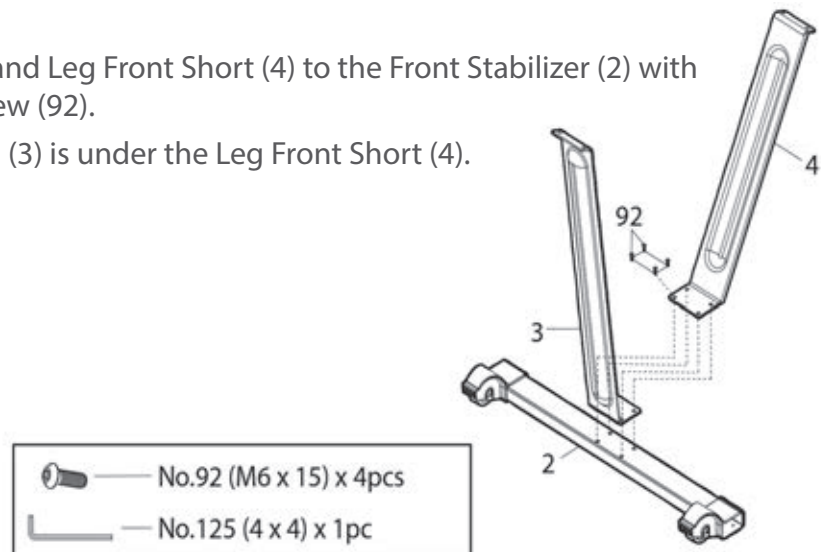

Step 2:

Attach the Front Stabilizer (2) to the Main Frame (1) with 4pcs Flat Head Hex Socket Screw (93).

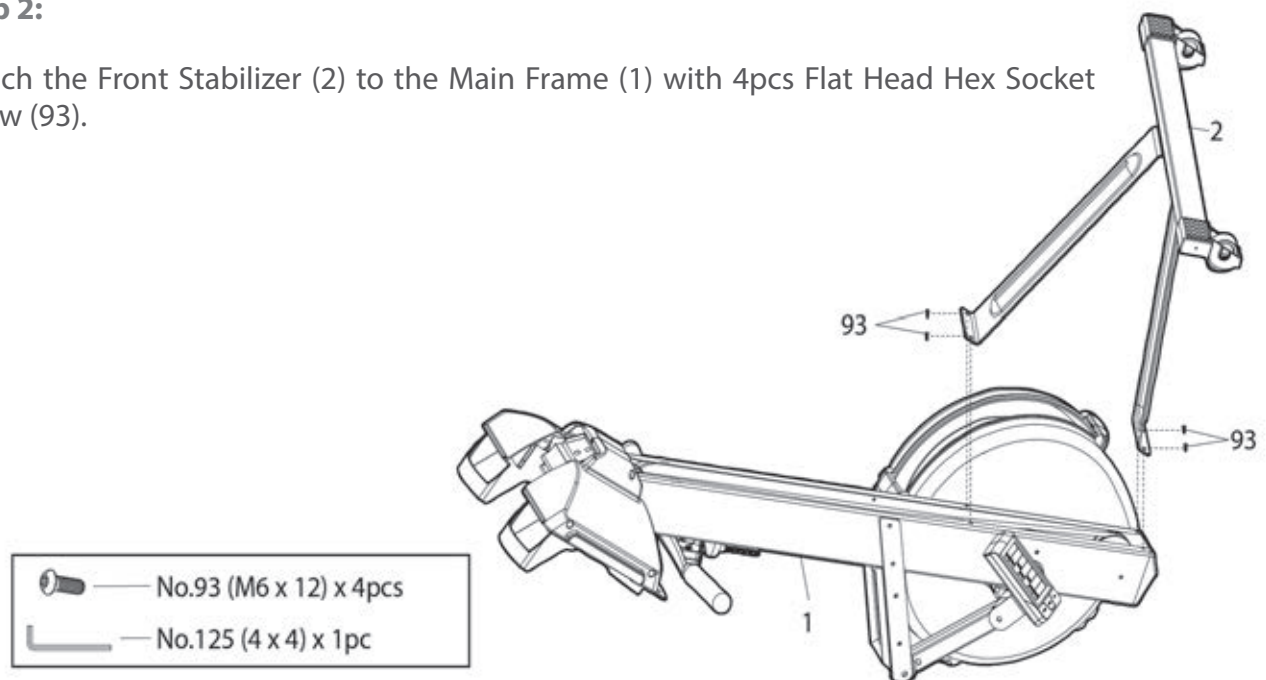

Step 3:

⚠ WARNING

At least two people are required when disconnecting or connecting the monorail. Do not attempt to lift the main frame if you have limitations in the musculoskeletal system. To prevent injury, keep fingers and hands away from the folding mechanism.

⚠ WARNING

+ Do not attempt to operate the unit when it is disassembled.

⚠ CAUTION

Do not lean on or lay anything on the product, as this may cause the product to become unstable and fall over.

ⓘ NOTICE

The rowing machine can be disassembled to save space during storage. This also facilitates transport.

When connecting the Aluminum Rail (11) to the Main Frame (1), please note that the groove at the bottom of Lower Hanger Plastic (38), is aligned with Hanger Shaft Threaded (59) between the foot pedals, and then press down to complete the installation.

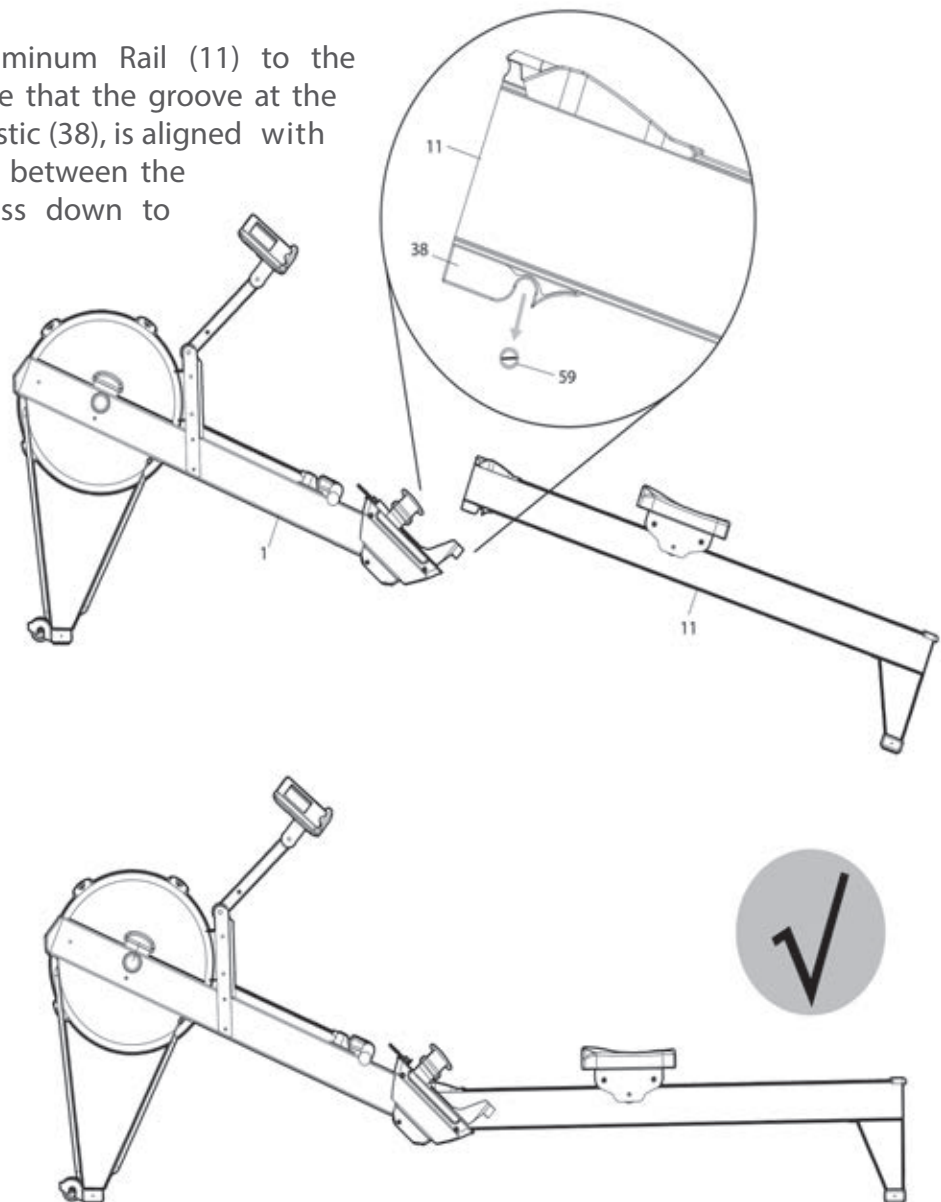

2.4 Adjustments

Damper

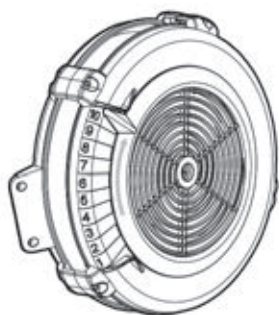

moving upwards - the gear is increased

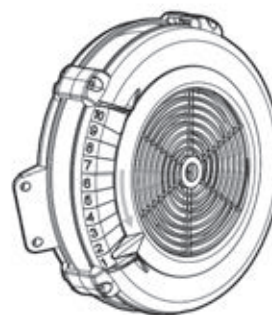

moving downwards - the gear is decreased

Heel Rest and Strap

There are several settings for the heel rest. Before you start with your training, adjust the heel rests correctly.

1. Loosen the strap by opening the Velcro fastener and place your foot on the heel rest through the strap.
2. Tighten the strap of the heel rest so far upwards that your heel is supported and the foot strap lies over the widest part of your foot.
3. Tighten the strap at the loosened end of the Velcro fastener and press the Velcro fastener back on.

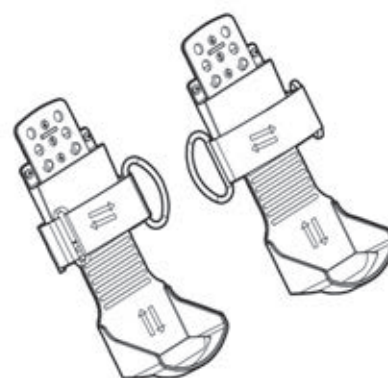

3 OPERATING INSTRUCTIONS

① NOTICE

Familiarise yourself with all the functions and setting options of the device before starting training. Have the proper use of this product explained to you by a specialist.

3.1 Console Display



TIME	User exercise time. Without setting, it will count up, setting range: 0:00 ~ 99:00 (\pm 1:00)
TIME/500	Display its value according to the signal input.
DIST	User exercise distance. Without setting, it will count up, setting range: 0 ~ 9990 (\pm 10)
CAL	User exercise calorie. Without setting, it will count up, setting range: 0 ~ 9990 (\pm 10)
SPM	Display its value according to the signal input
STROKES	Display its value according to the count input.
TOTAL STROKES	Display its value according to the cumulative count input.
WATT	Display its value according to the signal input.
PULSE	Current user exercise pulse. Setting range: 0 - 30 ~ 240 (\pm 1) BPM

MANUAL PROGRAM	Do Manual Program when RPM signal is detected without entering any mode.
INTERVAL 20-10	Interval exercise mode, exercise 20s, rest 10s.
INTERVAL 10-20	Interval exercise mode, exercise 10s, rest 20s.
INTERVAL CUSTOM	Interval exercise mode. The exercise time and rest time will be set by user.
TARGET TIME	The exercise time will be set by user.
TARGET DISTANCE	The exercise distance will be set by user.
TARGET CALORIES	The CALORIES will be set by user.
TARGET STROKES	The STROKES will be set by user.
TARGET PULSE	The heart rate will be set by user.

3.2 Key Functions

SET KEY	Press once to increase once, and long press to set rapid increase
MODE KEY	<ol style="list-style-type: none"> 1. Press this key to confirm and setting. 2. During exercise mode, set this key to pause.
RESET KEY	<ol style="list-style-type: none"> 1. In function selection mode, you can return to the previous function. 2. In setting mode, you can clear current setting value. 3. In pause mode, you can return to standby mode. 4. Long press this key for 3s to do TOTAL RESET, the console will clear current exercise value, except TOTAL STROKES value. <p>* TOTAL STROKES value will be cleared automatically, when the power supply is removed.</p>

3.3 Operation Instructions

1. Power On:

When power is on (or Press MODE/RESET for 3s), the BUZZER will beep for 2s, then LCD will display in full for 2s and then enter into the standby mode.

2. Standby Mode:

2-1 After powering on, the console will enter into standby mode MANUAL ("*" "8" display), INTERVAL ("*" "8" display), TARGET ("*" "8" display), TIME, TIME/500m, DISTANCE, CALORIE, PULSE, SPM, WATT, TOTAL STROKES, STROKES, will display circularly 1 second in turn in SCAN mode.

2-2 In standby mode, if no input is received either by; key operation, RPM signal or pulse input for 4mins the LCD will enter into Sleeping mode.

3. Exercise End Screen:

3-1 When the exercise ends, the console will display STOP by flashing ("*" "8" display), will display the finished exercise value. The window will then switch for 5s between the finished value and pulse value. The pulse value is the current value.

3-2 When the exercise ends, press the MODE key to continue.

3-3 When the exercise ends, press RESET key to enter into standby mode.

3-4 When the exercise ends, if no key is pressed or exercise is completed for 4 minutes, the console will enter into standby mode.

4. Exercise Stop Screen:

4-1 During exercising, press the MODE key to pause exercising and stop counting all values, PULSE will display the current value (picture 4-5).

4-2 When the exercise is paused, press MODE key to continue exercising again. Pressing the RESET key will enter into standby mode during the pause mode. Without pressing any key or finishing the exercise for 4 minutes in the pause mode, will also enter the console into standby mode.

5. The display screen of VR adjustment:

5-1 For standby mode and exercise mode, press SET key to enter the LEVEL display screen and display the current LEVEL value "LEVEL 01~10" (LEVEL 01, "*" "8" display), the LEVEL value will change with VR adjustment (LEVEL 05), press SET key again to exit the LEVEL adjustment screen and return to standby or exercise screen.

5-2 During exercising, the LEVEL adjustment does not affect the exercise function, and the exercise value continues to count.

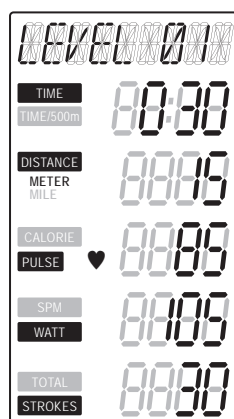

Level 01

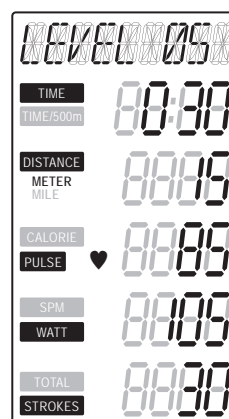

Level 05

6. Manual:

6-1 If there is RPM signal input in standby mode, the console will QUICK START immediately. (picture 2~3).

6-2 Or in standby mode, press MODE key twice to start MANUAL function.

6-3 The value of all functions will begin to accumulate according to the operation value, and switch display every 5s (picture 2~3).

6-4 During exercising, without pressing any key or if no signal is received for 4 minutes, then the console enters into the standby mode.



Picture 1

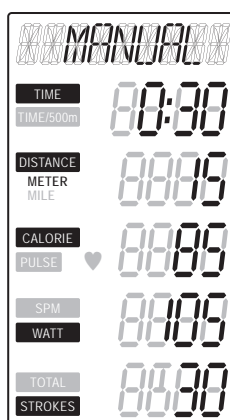

Picture 2

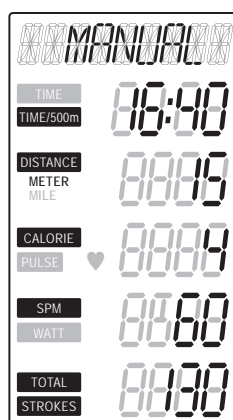

Picture 3

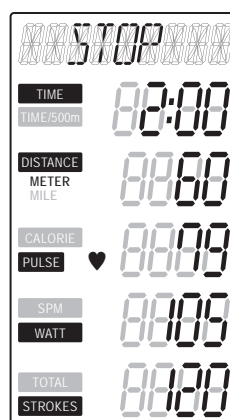

Picture 4

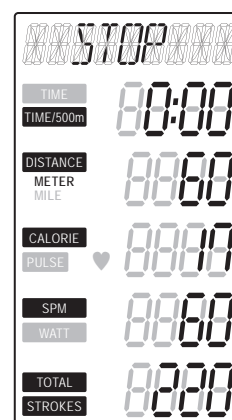

Picture 5

7.Interval:

In standby mode, press MODE key, and press SET KEY to select INTERVAL function (picture 6). Pressing MODE key to enter into INTERVAL the function selection.

7-1 INTERVAL 10/20

7-1-1 Pressing the SET key to select 10/20 (picture 7). To start 10/20 function press the MODE key. "READY" will flash on screen and the TIME window will display a 3-second countdown (picture 8).

7-1-2 "After "READY" displays for 3s, the LCD will display "WORK 01/08" ("*" "8" display) (picture 9), TIME begins to count down 20s. All function value will accumulate according to the operation values and switch display every 5 seconds.

7-1-3 When LCD displays the "REST 01/08" ("*" "8" display) (picture 10), TIME begins to count down 20s. All function value will accumulate according to the operation value and will switch display every 5 seconds. For the last 3s the LCD will flash and display "READY" ("*" "8" display) (picture 11).

7-1-4 7-1-3 and 7-1-4 will perform tautologically and circularly with each cycle counting plus 1 until displaying "WORK 08/08" after each exercise and then enter the end screen.

7-1-5 When doing the WORK function, if no signal is detected or any key is pressed for 4 minutes, the console will enter into standby mode.

7-1-6 The REST function does not enter into the Sleeping mode without pressing any key or a signal input.

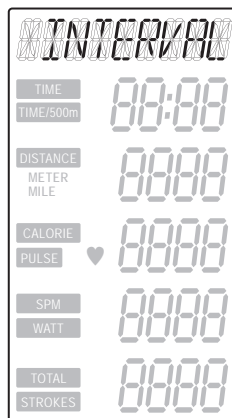

Picture 6



Picture 7

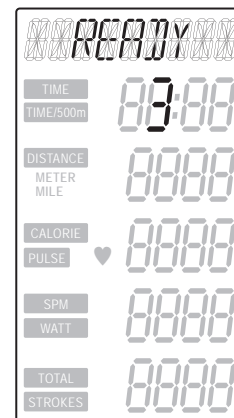

Picture 8

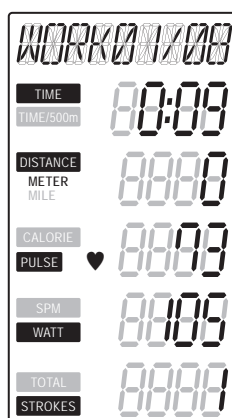

Picture 9

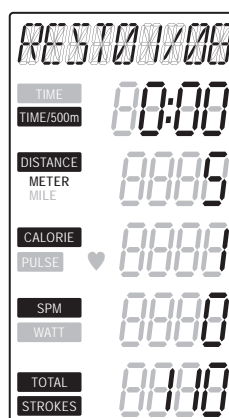

Picture 10

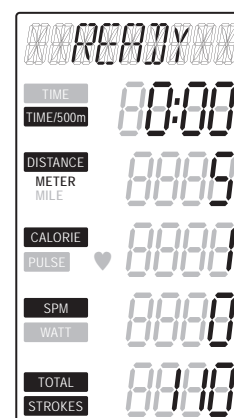

Picture 11

7-2 Interval 20/10

7-2-1 Pressing SET key to select 20/10 (Picture 12), press MODE key to start 20/10 function, "READY" flashing and TIME window displays a 3s countdown and the buzzer sounds 0.5s per seconds.

7-2-2 After "READY" 3s, LCD displays the "WORK 01/08" ("*" "8" display) the TIME will begin to count down 20s (picture 13). All function values will accumulate according to the operation value and switch display every 5s.

7-2-3 When the LCD displays the "REST 01/08" ("*" "8" display) the TIME will begin to count down 10s (picture 14). All function values will accumulate according to the operation value and switch display every 5 seconds. At the last 3s the LCD will flash and display "READY" ("*" "8" display).

7-2-4 7-2-3 and 7-2-4 will perform tautologically and circularly with each cycle count plus 1 until displaying "WORK 08/08" after each exercise then enter into the end screen and the buzzer sounds 0.5s.

7-2-5 When doing the WORK function if no signal is detected or any key is pressed for 4 minutes, the console will enter into standby mode.

7-2-6 The REST function does not enter into the Sleeping mode without pressing any key or a signal input.

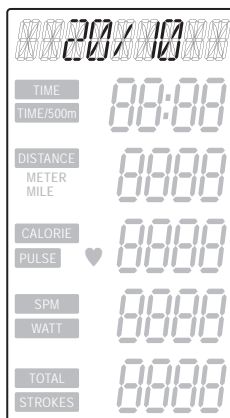

Picture 12

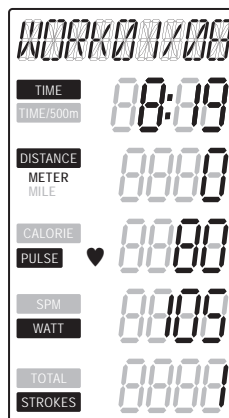

Picture 13

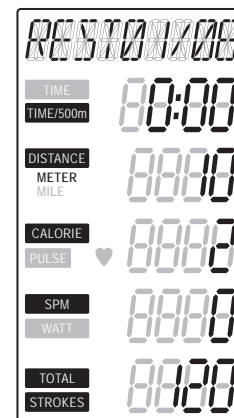

Picture 14

7-3 Interval Custom

7-3-1 Pressing the SET key to select CUSTOM function, once the display flashes with "CUSTOM", press the MODE key to set the CUSTOM function (picture 15).

7-3-2 When the LCD displays "SET ROUND" ("*" "8" display) the TIME window will display 01 and then flash (Picture 16). Press the SET button to set ROUND (the ROUND setting range is 01~99) which can be set circularly. After press MODE key, the buzzer beeps 0.5s, and then enters into the next setting.

7-3-3 When the LCD displays "SET WORK" ("*" "8" display) the TIME window will display 0:05 and then flash. Press the SET button to then set the WORK TIME (the setting range is 0:05-10:00), which can be set circularly. After pressing the MODE key, the buzzer will beep for 0.5s and then enter into the next setting.

7-3-4 When the LCD displays "SET REST" ("*" "8" display) the TIME window will display 0:05 and then flash. Press the SET button to then set the REST TIME (the setting range is 0:05-10:00), which can be set circularly. After pressing the MODE key, the buzzer will beep for 0.5s and then enter into the exercise screen (picture 18).

7-3-5 When the LCD flashes "READY", the TIME will count down 3s and the buzzer will beep for 0.5s every second.

7-3-6 After displaying READY for 3s, the LCD will display "WORK 01/XX" ("*" "8" display), the TIME will begin to count down according to the set time. All function values will accumulate according to the operation values and switch display every 5 seconds. (Picture 19~20).

7-3-7 When the LCD displays "REST 01/XX" ("*" "8" display) the TIME begins to count down according to the REST time. All function values will accumulate according to the operation values and switch display every 5 seconds. For the last 3s the LCD will flash and display "READY" ("*" "8" display).

7-3-8 7-3-3 and 7-3-4 will perform tautologically and circularly with each cycle count plus 1 until displaying "WORK XX/XX" after the last exercise then enter into the end screen.

7-3-9 When doing the WORK function if no signal is detected or any key is pressed for 4 minutes, the console will enter into standby mode.

7-3-10 The REST function does not enter into the Sleeping mode without pressing any key or a signal input.



Picture 15

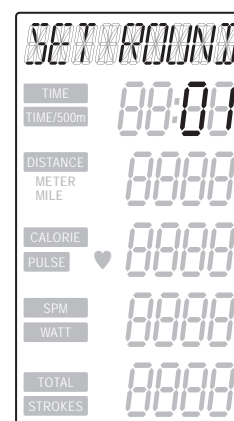

Picture 16

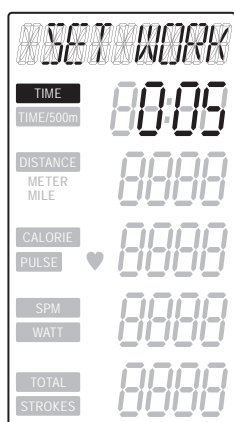

Picture 17



Picture 18

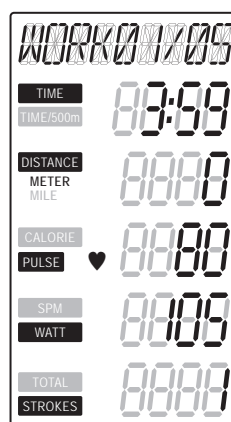

Picture 19

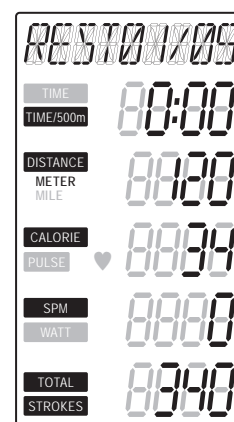

Picture 20

8. Target:

In standby mode, press the MODE and SET keys to select TARGET function. The LCD displays TARGET flashing ("*" "8" display) (picture 21). Pressing MODE key to enter into TARGET FUNCTION SELECTION.

8-1 Target Time

8-1-1 Toggle the TARGET TIME function (picture 22) and press the MODE key to start the TIME setting function.

8-1-2 When the LCD displays "SET" by flashing ("*" "8" display), 0:00 flashes in the TIME window (picture 23), press the SET key to set the target time (the setting range is 0:00~99:00) which can be set circularly. Press the MODE key to confirm and the console will enter into the exercise mode.

8-1-3 When the LCD displays the "TARGET" and "TIME" ("*" "8" display) the display will switch every 2s (picture 24~25). All function values will accumulate according to the operation values and switch display every 5s.

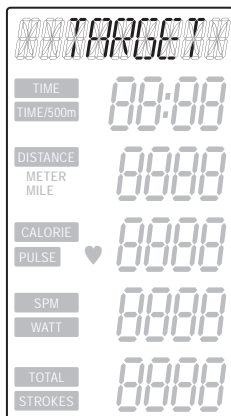

Picture 21

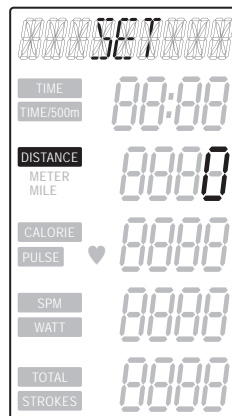

Picture 22



Picture 23

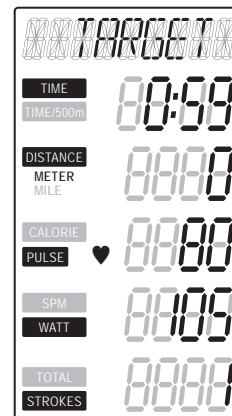

Picture 24

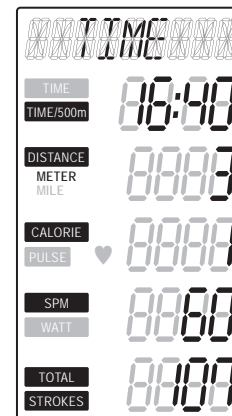

Picture 25

8-2 Target Distance

8-2-1 Toggle the TARGET DISTANCE function until the LCD flashes and displays "TARGET" ("*" "8" display). The DISTANCE window will flash and display the DISTANCE (picture 26) and then press the MODE key to start setting the DISTANCE function.

8-2-2 When the LCD displays and flashes "SET" ("*" "8" display), and 0 flashes in the DISTANCE window (picture 27), press the SET key to set the target distance (the setting range is 0~9990) which can be set circularly. Press the MODE key to confirm and the console will enter into exercise mode and a 0.5s buzzer will sound.

8-2-3 When the LCD displays the "TARGET" and "DISTANCE" ("*" "8" display) it will switch display every 2s (picture 28~29). All function values will accumulate according to the operation values and switch display every 5s.

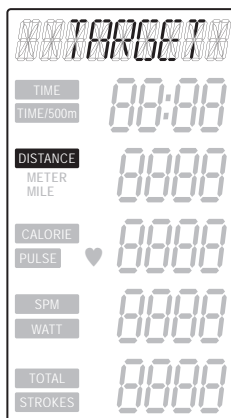

Picture 26

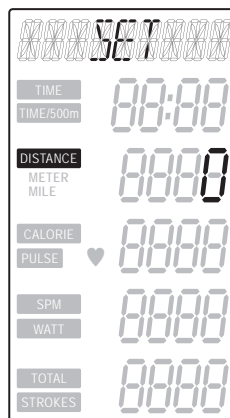

Picture 27

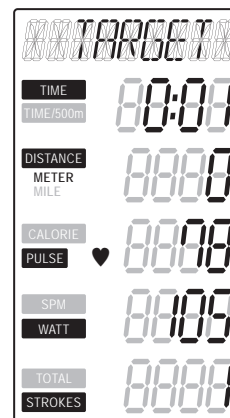

Picture 28

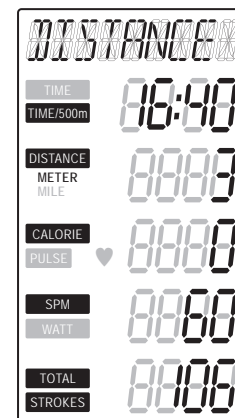

Picture 29

8-3 Target Calories

8-3-1 Toggle the TARGET CALORIES function and once the LCD flashes and displays "TARGET" ("*" "8" display). The CALORIES window will display with CALORIES flashing (picture 30).

Press the MODE key to start setting the CALORIES function.

8-3-2 When LCD flashes and display "SET" ("*" "8" display), and 0 will flash in the CALORIES window (picture 31). Press the SET key to set target CALORIES (the setting range is (0~9990) which can be set circularly. Press MODE key to confirm and the console will enter into the exercise mode.

8-3-3 When the LCD displays the "TARGET" and "CALORIES" ("*" "8" display) it will switch display every 2s (picture 32~33). All function values will accumulate according to the operation values and the display will switch every 5s.

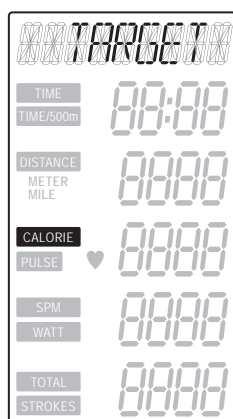

Picture 30

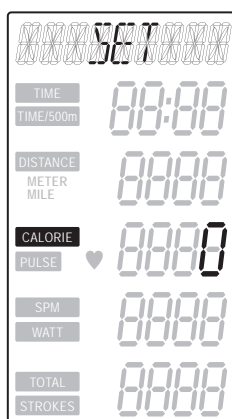

Picture 31

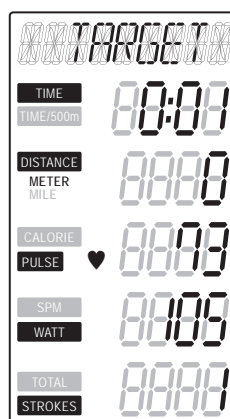

Picture 32

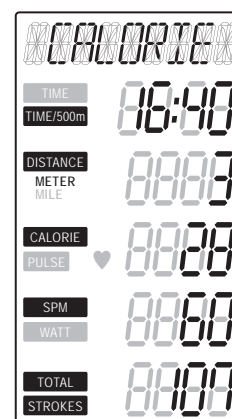

Picture 33

8-4 Target Strokes

8-4-1 Toggle the TARGET DISTANCE function until the LCD flashes and displays "TARGET" ("*" "8" display). The STROKES window will flash and display STROKES (picture 34). Press the MODE key to start setting the STROKES function.

8-4-2 When the LCD display keeps flashing with "SET" ("*" "8" display) (picture 35) and 0 flashes in the STROKES window, press the SET key to set target STROKES (the setting range is 0~9990), which can be set circularly. Press the MODE key to confirm and the console will enter into the exercise mode.

8-4-3 When the LCD displays the "TARGET" and "STROKES" ("*" "8" display) it will switch display every 2s (picture 36~37). All function values will accumulate according to the operation values and the display will switch every 5s.

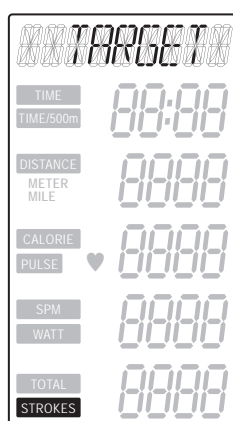

Picture 34



Picture 35

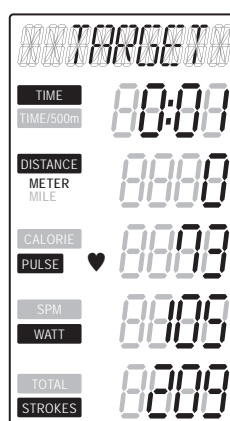

Picture 36

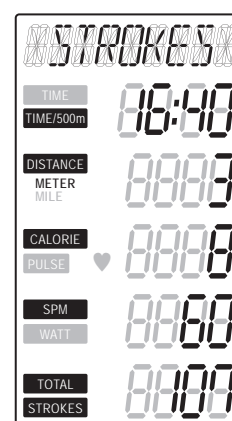

Picture 37

8-5 Target Pulse

8-5-1 Toggle the TARGET DISTANCE function until the LCD flashes and displays "TARGET" ("****8" display). The PULSE window will flash and display PULSE (picture 38). Press the MODE key to start setting the PULSE function.

8-5-2 When the LCD flashes and displays "SET" ("****8" display) (picture 39), 100 will flash in the PULSE window. Press the SET key to set the target PULSE (the setting range is 30-230) which can be set circularly. Press the MODE key to confirm and the console will enter into the exercise mode.

8-5-3 When the LCD displays the "TARGET" and "PULSE" ("****8" display) it will switch display every 2s (picture 40~41). All function values will accumulate according to the operation values and switch display in every 5s.

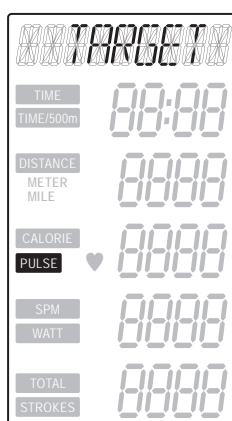

Picture 38

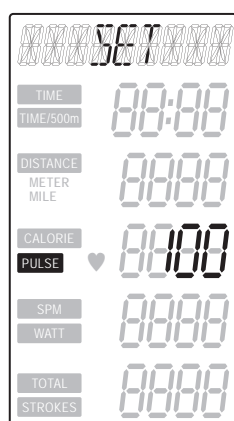

Picture 39

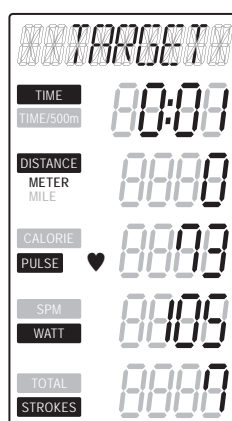

Picture 40

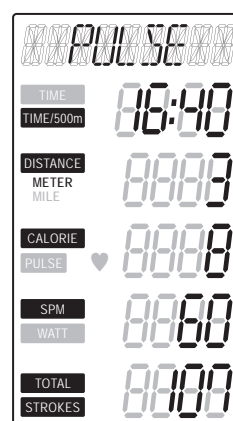

Picture 41

9. Special Mode

9-1 Switch KM/ ML

9-1-1 Pressing MODE+SET for 2s to enter into switch KM/ML mode.

9-1-2 LCD displays "CLIENT ID" and program version ("*" "8" display), TIME window shows console model name (picture 42).

9-1-3 In the switch KM/ML mode, press SET to adjust the KM/ML,

press MODE to confirm the setting, and RESET is invalid KEY.

9-1-4 The console has no storage function, so when the battery is removed it reverts to the preset value.

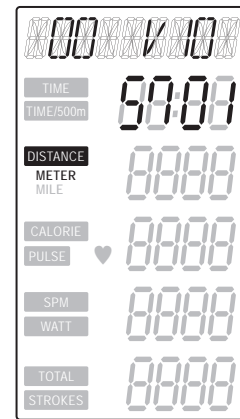

Picture 42

9-2 Bluetooth Connection Mode

9-2-1 The console can connect to APP and bluetooth heartbeat in any mode except sleeping mode.

9-2-2 After the console connected APP, LCD will display "BT" ("*" "8" display) (picture 43).

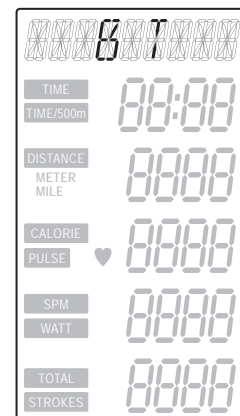

Picture 43

10. VR Correction Mode :

10-1 During the standby mode, press MODE+RESET KEY for 3s to enter into VR correction mode.

10-2 TIME window will display "L", DISTANCE window displays the current the AD value of VR (Picture 44). Adjust Damper (Picture 45) to the first level and press ENTER KEY to confirm.

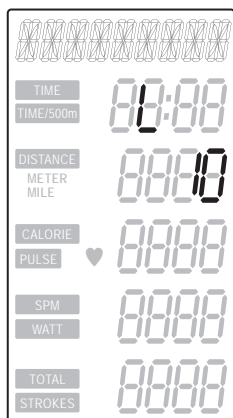

Picture 44

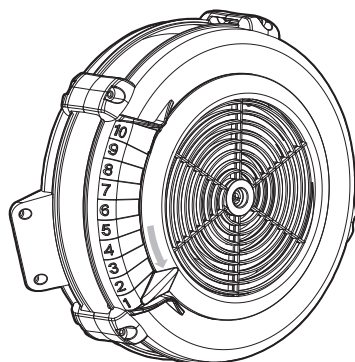

Picture 45



Picture 45

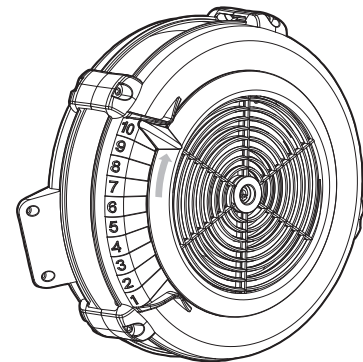

Picture 47

10-3 After confirming the first level value of VR , "H" will be displayed in the TIME window, and the actual AD value of VR will be displayed in the DISTANCE window (Picture 46). Adjust Damper (Picture 47) to the highest level and press ENTER KEY to confirm after the adjustment.

10-4 After setting the first and highest level values of VR, the console will restart and cut the set values into 10 segments on average.

10-5 When adjusting Damper, attach the pointer to the baffle plate.

3.4 Notes on Correct Rowing

Body moves towards the handle

Wrong

At the end of the movement, the body will be pulled forwards towards the handles instead the handles to the body.

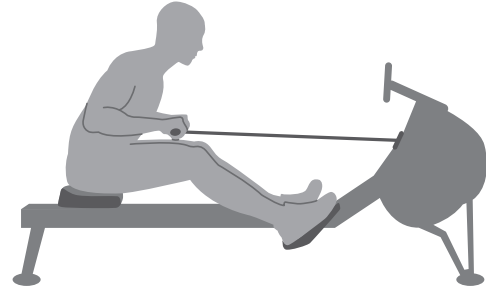

Right

At the end of the movement, the user slightly leans back, holds the legs down, keeps the upper body straight and pulls the handle to the body.

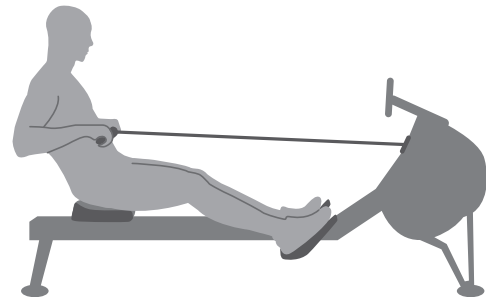

Straddled elbows

Wrong

The user's elbows are straddled from the body at the end of the movement and the handle is at the height of the breast.



Right

Pull the handle to the body with straight wrists and the elbows close to the body. The elbows are brought behind the head while the handle is pulled to your waist.



Do not completely extend

Wrong

At the end of the movement, the user completely stretches the leg and knee.

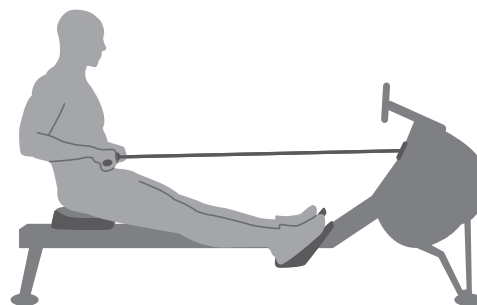

Right

Keep your knee slightly bent at all times even at the end of the movement instead of stretching it completely.

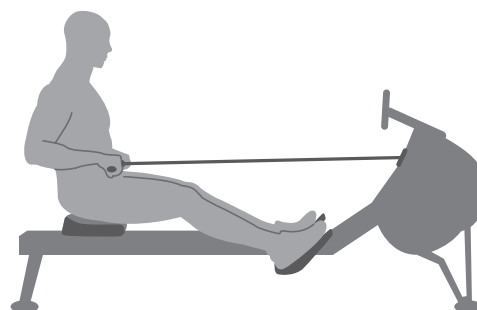

Leaning too far forward

Wrong

The body is bent too far forward. The shins are no longer vertical. The head and shoulders are facing the feet. The body is therefore in a weak position to execute the movement.

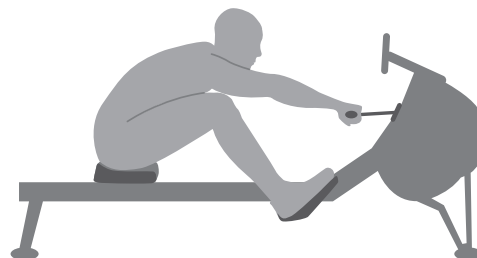

Right

The shins are vertical. The body is pressed against the legs, the arms are completely stretched out in front and the body is slight bent forward. This position should be pleasant.

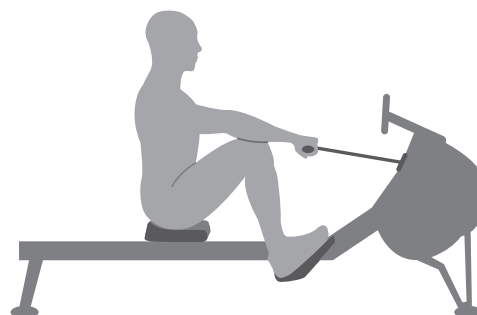

Rowing with bent arms

Wrong

The user begins the movement with the arms instead of first pressing with the legs.



Right

The user begins by stretching out the legs, relaxing the back and stretching the arms.



Bent wrists

Wrong

The user bends the wrists during the movement.

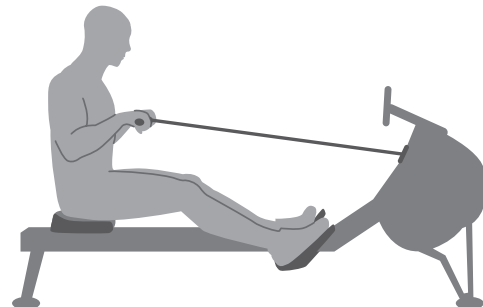

Right

Always execute the rowing movement with straight wrists.

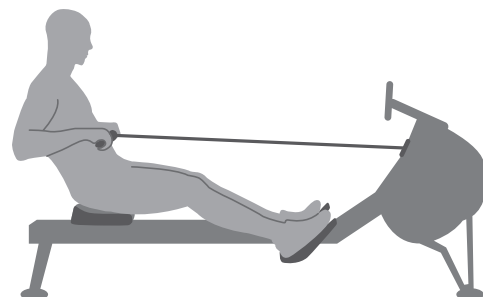

4.1 General Instructions

► **ATTENTION**

- + Make sure that the equipment is protected from moisture, dust and dirt in the selected storage location. The storage location should be dry and well ventilated and have a constant ambient temperature between 5°C and 45°C.

⚠ **WARNING**

- + The storage location should be chosen so that improper use by third parties or children can be prevented.

4.2 Transportation Wheels

► **ATTENTION**

If you want to transport your equipment over particularly sensitive and soft floor coverings, such as parquet, planks or laminate, lay out the transport route with cardboard or similar to avoid possible floor damage.

1. Stand behind the equipment and lift it until the weight is transferred to the transportation wheels. After that, you easily can move the equipment to a new position. For long transport distances the equipment should be disassembled and safely packed.
2. Select the new location by following the instructions in the section 1.3 of this manual.

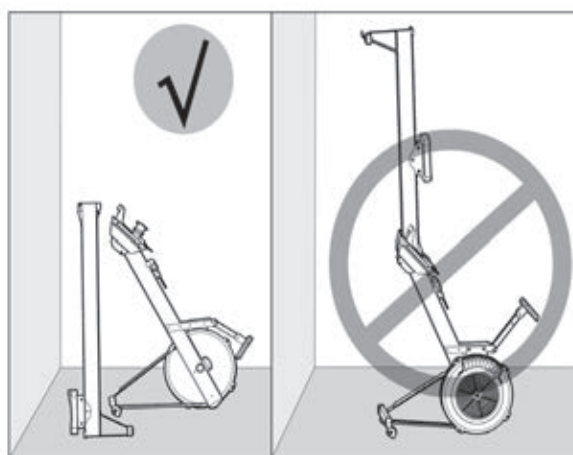
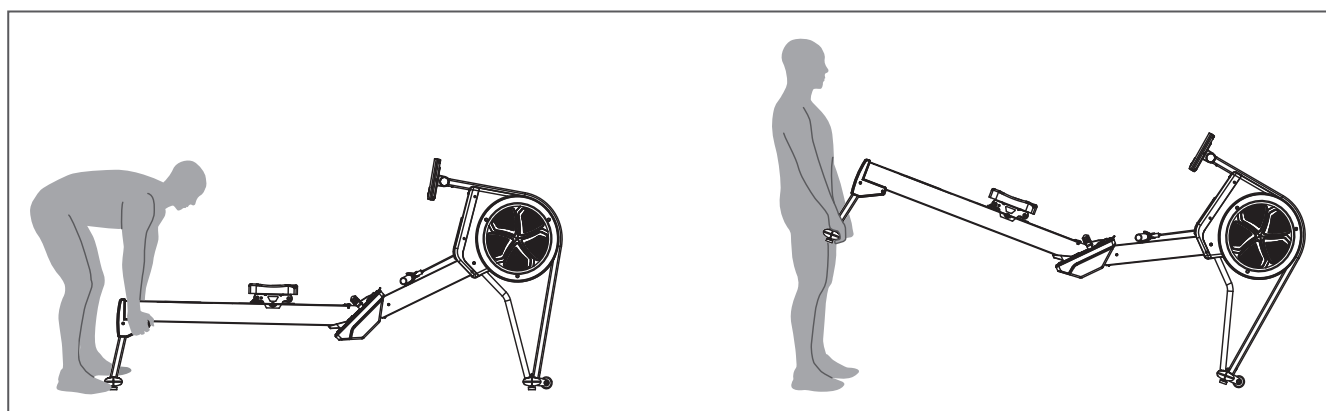

5.1 General Instructions

⚠ WARNING

- + Do not make any improper changes to the equipment.

⚠ CAUTION

- + Damaged or worn components may affect your safety and the life of the equipment. Therefore, immediately replace damaged or worn components. In such a case, contact the contract partner. The equipment must not be used until it has been repaired. If necessary, use only original spare parts.

▶ ATTENTION

- + In addition to the instructions and recommendations for maintenance and care given here, additional service and/or repair work may be necessary; this must only be carried out by authorised service technicians.

5.2 Faults and Fault Diagnosis

The equipment undergoes regular quality controls during production. Nevertheless, faults or malfunctions may occur. Frequently, individual parts are responsible for these disturbances, an exchange is usually sufficient. Please refer to the following overview for the most common errors and how to correct them. If the equipment still does not function properly, contact your contract partner.

Fault	Cause	Solution
Heart rate is not received	<ul style="list-style-type: none"> + Sources of interference in the room + unsuitable chest strap + Wrong position of chest strap + Batteries empty 	<ul style="list-style-type: none"> + Eliminate sources of interference (e.g. mobile phones, loudspeakers, WLAN, lawn mower and vacuum cleaner robots ...) + Use a suitable chest strap (see recommended accessories). + Reposition chest strap and/or moisten electrodes + Changing batteries
LCD error – software error etc.	<ul style="list-style-type: none"> + Batteries empty + Console has no power supply 	<ul style="list-style-type: none"> + Hold Reset to start the console again. + Disconnect and connect again all cable connections. + Changing batteries + Contact a service technician of your contract partner.

5.3 Maintenance and Inspection Calendar

To avoid damage from body sweat, the equipment must be cleaned with a damp towel (no solvents!) after each training session.

The following routine tasks must be performed at the specified intervals:

Part	Weekly	Monthly	Quarterly	Half-yearly	Yearly
Display console	C	I			
Lubrication of the moving parts				I	
Plastic covers	C	I			
Screws and cable connections		I			
Legend: C = clean; I = inspect					

Lubrication of the chain

Lubricate the chain at least every six months or even better after approx. 50 operating hours. Use a non-fraying cloth as well as 20W motor or multi-purpose oil. Drop approx. one teaspoon of the oil on the cloth. Then pull out carefully the chain on the handle to the fence. Wipe along the chain with the cloth several times. Then remove the remaining oil with a dry cloth.

Cleaning the rail

Before the training, wipe the rail with a damped cloth to remove any dust.

6 DISPOSAL

At the end of its operational life, this equipment cannot be disposed of in normal household waste. Instead, it must be disposed of via an electricals recycling centre. Further information can be obtained from your local authority's recycling service.



The materials can be recycled as per their symbols. Through the reuse, recycling of materials or other forms of recovery of old equipment, you make an important contribution to the protection of the environment.

7 RECOMMENDED ACCESSORIES

To make your training experience even more efficient and pleasant, we recommend that you add suiting accessories to your fitness equipment. This could be a floor mat, for example, which makes your fitness equipment stand more securely and also protects the floor from falling sweat, but it could also be additional handrails on some treadmills or silicone spray to keep moving parts in good shape.

If you have purchased a fitness machine with pulse training and want to train your heart rate, we strongly recommend that you use a compatible chest strap, as this ensures optimum transmission of the heart rate. You may want to buy additional grips or weights for multi gyms.

Our range of accessories offers the highest quality and makes training even better. If you would like to find out more about compatible accessories, please go to the detail page of the product in our webshop (the easiest way is to enter the article number in the search field above) and go to the recommended accessories on this page. Alternatively, you can use the QR code provided. Of course, you can also contact our customer service: by telephone, e-mail, in one of our branches or via our social media channels. We will be happy to advise you!



floor mat



chest strap



chest strap contact gel



towels



silicone spray

8.1 Serial Number and Model Name

In order to provide you with the best possible service, please have the model name, article number, serial number, exploded drawing and parts list ready. The corresponding contact options can be found in chapter 10 of this operating manual.

ⓘ NOTICE

The serial number of your equipment is unique. It's located on a black sticker.

Enter the serial number in the appropriate field.

Serial number:

Brand / Category:

Model Name:

Article Number:

8.2 Parts list

No.	Description	Qty.	No.	Description	Qty.	No.	Description	Qty.
1	Main Frame	1	53	Bearing	1	105	Nut	4
2	Front Stabilizer	1	54	Bearing	4	106	Nut	4
3	Leg Front Long	1	55	Console	1	107	Acorn Nut	1
4	Leg Front Short	1	56	Spacer for Seat Roller	4	108	Washer	2
5	Guide Bracket	2	57	Spacer for Seat Roller	2	109	Washer	4
6	Console Support Plate	1	58	Long Spacer for Guide Wheel	3	110	Washer	1
7	Pedal Support Plate L	1	59	Hanger Shaft Threaded	2	111	Washer	5
8	Pedal Support Plate R	1	60	Axle	1	112	Washer	4
9	Pedal Joint Pipe	2	61	Short Spacer for Guide Wheel	1	113	Inner Circlip	4
10	Counterweight Disk	1	62	Washer	4	114	Inner Circlip	1
11	Aluminum Rail	1	63	Pulley	2	115	Sensor Wire	1
12	Rear Stabilizer	1	64	Spacer Sleeve	1	116	VR	1
13	Front End cap L	1	65	Chain	1	117	Sensor Wire	1
14	Front End cap R	1	66	Bearing Sleeve	1	118	Sensor Screw	4
15	Rear End cap	2	67	Gear wheel	1	119	Rubber Band	2
16	Pedal Support	2	68	Swivel Bushing	1	120	Cross Head Screw	3
17	Pedal Cap	2	69	Stator	1	121	Acorn Nut	4
18	Flywheel Cover Back	1	70	Connecting Sheet	2	122	Damper Plate	1
19	Flywheel Cover Front	1	71	Chain Connector	2	123	VR Plate	1
20	Damper	1	72	U Bolt	1	124	With Cross Allen Wrench	1
21	Chain Guide	1	73	U-Block	1	125	Allen Wrench	1
22	Console Holder	2	74	Bungee Cord hook	2	126	Nut	1
23	Cover For Pedals	2	75	Magnet	1	127	Thin Nut	4
24	Elastic Piece	1	76	Pedal Strap	2			
25	Upper Hanger Plastic	1	77	Seat	1			
26	Handlebar Seat	1	78	Bungee Cord	1			
27	End Cap	1	79	Axis Of Connection	1			
28	Perf Connector	2	80	Lower Die Cast Hanger	1			
29	Sensor Cover	1	81	Upper Die Cast Hanger	1			
30	Sensor Base	1	82	Plastic Sleeve For 6003 Bearing	1			
31	Bearing Cover	1	83	Plastic Sleeve For 6001 Bearing	1			
32	Spacer	1	84	Cross Head Self Tapping Screw	14			
33	Seat Carriage	2	85	Cross Head Self Tapping Screw	4			
34	Outlet Perf	1	86	Cross Flat Head Self Tapping Screw	1			
35	Stainless Plate	1	87	Hexagon Socket Screws With Cylindrical Head	1			
36	Rear Bumper	1	88	Cross Head Screw	16			
37	Rail Support	1	89	Cross Head Bolt	4			
38	Lower Hanger Plastic	1	90	Flat Head Hex Socket Bolt	2			
39	Flywheel	1	91	Flat Head Hex Socket Bolt	2			
40	Seat Roller	2	92	Flat Head Hex Socket Screw	8			
41	Spacer below seat	2	93	Flat Head Hex Socket Screw	30			
42	Wheel For Moving	2	94	Flat Head Hex Socket Bolt	2			
43	Guide Wheel	2	95	Flat Head Hex Socket Screw	8			
44	Pulley	4	96	Flat Head Hex Socket Bolt	2			
45	Pulley Short Bushing	6	97	Flat Head Hex Socket Bolt	1			
46	Pulley Long Bushing	2	98	Flat Head Hex Socket Bolt	1			
47	Gasket	1	99	Outer Hexagonal Bolt	2			
48	Handlebar	1	100	Outer Hexagonal Screw	4			
49	Handlebar Grips	2	101	Hex Nut	1			
50	Bearing	8	102	Hex Nut	4			
51	Bearing	3	103	Hex Nut	4			
52	One-way Bearing	1	104	Nut	6			

8.3 Exploded Drawing

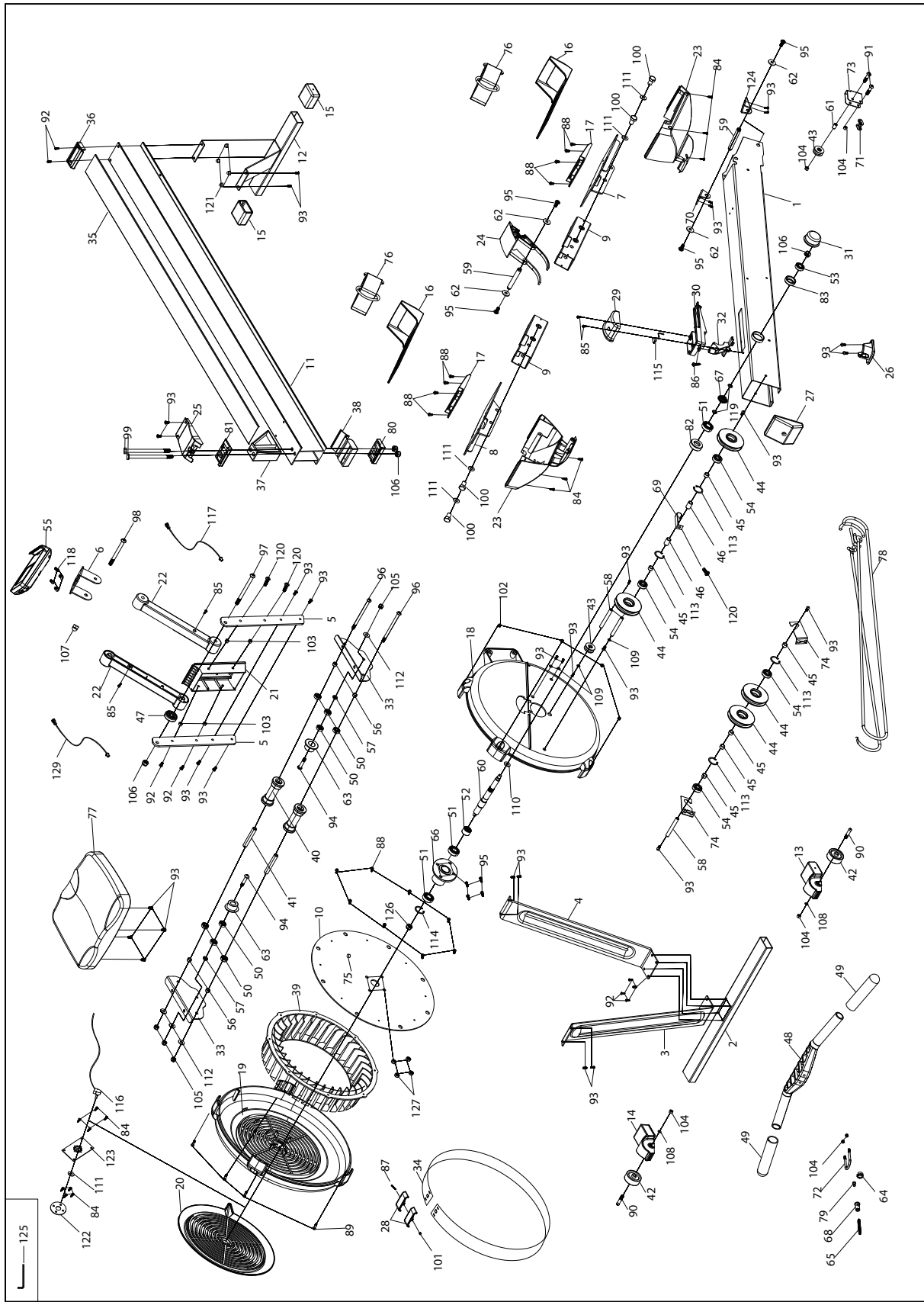

Training equipment from Taurus® is subject to strict quality control. However, if a fitness equipment purchased from us does not work perfectly, we take it very seriously and ask you to contact our customer service as indicated. We are happy to help you by phone via our service hotline.

Error Descriptions

Your fitness equipment is developed for long-term, high-quality training. However, should a problem arise, please first read the operating instructions. For further assistance, please contact your contract partner or call our service hotline. To ensure your problem is solved as quickly as possible, please describe the defect as exactly as possible.

In addition to the statutory warranty, we provide a warranty for every fitness equipment purchased from us according to the following provisions.

Your statutory rights are not affected.

Warrantee

The warrantee is the first/original buyer.

Warranty periods

The following warranty periods begin on delivery of the fitness equipment.

Warranty period

The warranty periods, shown on our web shop, begin on delivery of the fitness equipment. The respective warranty periods for your equipment can be found on its product website.

Repair Costs

According to our choice, there will either be a repair, a replacement of individual damaged parts or a complete replacement. Spare parts, that have to be mounted while assembling the equipment, have to be replaced by the warrantee personally and are not a part of repair. After the expiration of the warranty period for repair costs, a pure parts warranty applies, which does not include the repair, installation and delivery costs.

The terms of use are defined as follows:

- + Home use: solely for private use in private households up to 3 hours per day
- + Semi-professional use: up to 6 hours per day (e. g. rehabilitation centres, hotels, clubs, company gyms)
- + Professional use: more than 6 hours per day (e. g. commercial gyms)

Warranty Service

Within the warranty period, equipment which develops faults as a result of material or manufacturing defects, will be repaired or replaced at our discretion. Ownership of equipment or parts of equipment which have been replaced is transferred to us. The warranty period is not extended nor does a new warranty period begin following repair or replacement under the warranty.

Warranty Conditions

For the warranty to be valid, the following steps must be taken:

Please contact our customer service by email or phone. If the product under warranty has to be sent in for repair, the seller bears costs. After expiry of the warranty, the buyer bears the costs of transport and insurance. If the fault is covered by our warranty, you will receive a new or repaired equipment in return.

Warranty claims are invalid in case of damage resulting from:

- + misuse or improper handling
- + environmental influences (moisture, heat, electrical surge, dust, etc.)
- + failure to follow the current safety measures for the equipment
- + failure to follow the operating instructions
- + use of force (e. g. hitting, kicking, falling)
- + interventions which were not carried out by one of our authorized service centres
- + unauthorised repair attempts

Proof of Purchase and Serial Number

Please make sure that you are able to provide the appropriate receipt when claiming on your warranty. So that we can clearly identify the model of your equipment, and for the purposes of our quality control, you will need to give the serial number of your equipment, when contacting the service team. Where possible please have your serial number and your customer number ready when you call our service hotline. It will help us to deal with your request swiftly.

If you cannot find the serial number on your fitness equipment, our service team is at your disposal to offer further information.



































Service outside of the Warranty Period

We are also happy to issue an individual cost estimate if there is a problem with your fitness equipment after the warranty has expired, or in cases which do not fall under the terms of the warranty, e. g. normal wear and tear. Please contact our customer service team to find a quick and cost-effective solution to your problem. In such a case you will be responsible for the delivery costs.

Communication

Many problems can be solved just by speaking to us as your specialist supplier. We know how important it is to you as a user of the fitness equipment to have problems solved quickly and simply, so you can enjoy working out with minimal interruption. For that reason, we also want to resolve your queries quickly and in a straightforward manner. Thus, please always keep your customer number and the serial number of the faulty equipment handy.

10 CONTACT

DE	DK	FR
<p>TECHNICAL SUPPORT</p> <p> +49 4621 4210-900</p> <p> +49 4621 4210-698</p> <p> technik@sport-tiedje.de</p> <p> Mo - Fr 08:00 - 18:00 Sa 09:00 - 18:00</p> <p>SERVICE</p> <p> 0800 20 20277 (Freecall)</p> <p> info@sport-tiedje.de</p> <p> Mo - Fr 08:00 - 21:00 Sa 09:00 - 21:00 So 10:00 - 18:00</p>	<p>TECHNICAL SUPPORT & SERVICE</p> <p> 80 90 16 50</p> <p>+49 4621 4210-945</p> <p> info@fitshop.dk</p> <p> Mo - Fr 08:00 - 18:00 Sa 09:00 - 18:00</p>	<p>TECHNICAL SUPPORT & SERVICE</p> <p> +33 (0) 172 770033</p> <p>+49 4621 4210-933</p> <p> service-france@fitshop.fr</p> <p> Mo - Fr 08:00 - 18:00 Sa 09:00 - 18:00</p>
	PL	BE
	<p>TECHNICAL SUPPORT & SERVICE</p> <p> 22 307 43 21</p> <p>+49 4621 42 10-948</p> <p> info@fitshop.pl</p> <p> Mo - Fr 08:00 - 18:00 Sa 09:00 - 18:00</p>	<p>TECHNICAL SUPPORT & SERVICE</p> <p> 02 732 46 77</p> <p>+49 4621 42 10-932</p> <p> info@fitshop.be</p> <p> Mo - Fr 08:00 - 18:00 Sa 09:00 - 18:00</p>
UK	NL	INT
<p>CUSTOMER CARE</p> <p> +44 141 737 2249</p> <p> customercare@powerhouse-fitness.co.uk</p> <p> Mo - Fr 10am - 6pm</p>	<p>TECHNICAL SUPPORT & SERVICE</p> <p> +31 172 619961</p> <p> info@fitshop.nl</p> <p> Ma - Do 09:00 - 17:00 Vr 09:00 - 21:00 Za 10:00 - 17:00</p>	<p>TECHNICAL SUPPORT & SERVICE</p> <p> +49 4621 4210-944</p> <p> service-int@sport-tiedje.de</p> <p> Mo - Fr 8am - 6pm Sat 9am - 6pm</p>
	AT	CH
	<p>TECHNICAL SUPPORT & SERVICE</p> <p> 0800 20 20277 (Freecall)</p> <p>+49 4621 42 10-0</p> <p> info@sport-tiedje.at</p> <p> Mo - Fr 08:00 - 18:00 Sa 09:00 - 18:00</p>	<p>TECHNICAL SUPPORT & SERVICE</p> <p> 0800 202 027</p> <p>+49 4621 42 10-0</p> <p> info@sport-tiedje.ch</p> <p> Mo - Fr 08:00 - 18:00 Sa 09:00 - 18:00</p>

Please find a detailed overview including address and opening hours for all stores of the Sport-Tiedje Group in Germany and abroad on the following website:

www.sport-tiedje.com/en/stores

WE LIVE FITNESS

WEBSHOP AND SOCIAL MEDIA

Sport-Tiedje is Europe's largest specialist store for home fitness equipment with currently 80 stores and one of the world's most renowned online mail order companies for fitness equipment. Private customers order via the 25 web shops in the respective national language or have their desired equipment assembled on site. In addition, the company supplies fitness studios, hotels, sports clubs, companies and physio practices with professional equipment for endurance and strength training.

Sport-Tiedje offers a wide range of fitness equipment from renowned manufacturers, high-quality in-house developments and comprehensive services, such as a build-up service and sports scientific advice before and after the purchase. The company employs numerous sports scientists, fitness trainers and competitive athletes.

Visit us also on our social media platforms or our blog!



www.sport-tiedje.co.uk
www.sport-tiedje.de/blog



www.facebook.com/SportTiedje



www.instagram.com/sporttiedje



www.youtube.com/user/sporttiedje

TAURUS

cardiostrong

BODYCRAFT

cardiojump



Notes

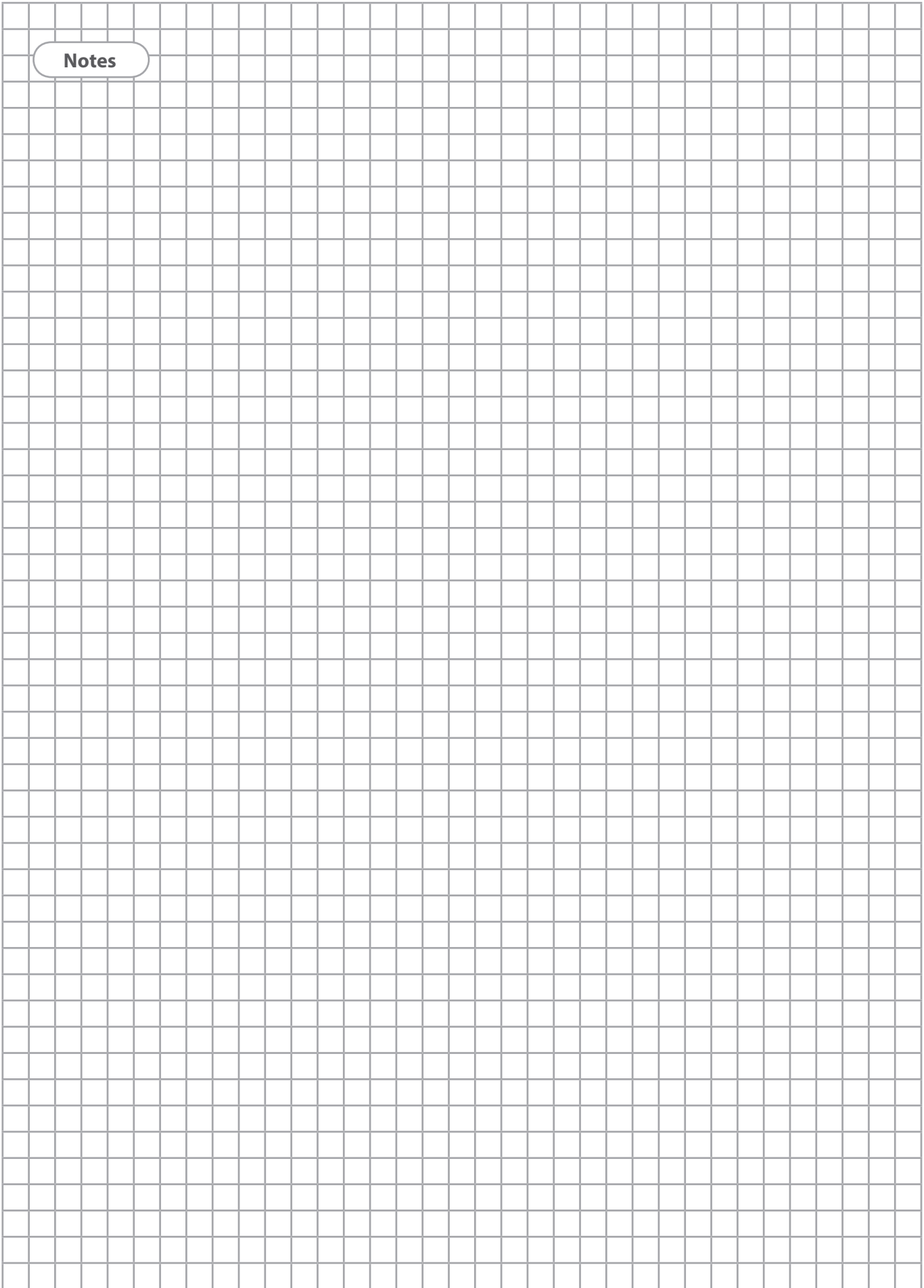

Notes

A large grid of graph paper for taking notes, consisting of 20 columns and 30 rows of small squares.

TAURUS®

Taurus Elite Rower