

SPIRIT

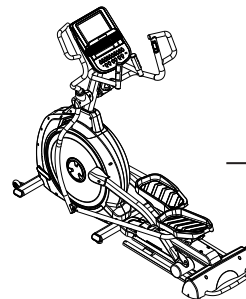

XE395ENT ELLIPTICAL TRAINER
OWNER'S MANUAL

TABLE OF CONTENTS

5	PRODUCT REGISTRATION
6	IMPORTANT SAFETY INSTRUCTIONS
7	IMPORTANT ELECTRICAL INSTRUCTIONS
9	IMPORTANT OPERATION INSTRUCTIONS
10	XE395ENT ASSEMBLY INSTRUCTIONS
18	CONSOLE OPERATION
31	PROGRAMS
43	USING HEART RATE TRANSMITTER
46	USING THE SPIRIT+ APP
47	GENERAL MAINTENANCE
48	MANUFACTURER'S LIMITED WARRANTY
50	EXPLODED VIEW
51	PARTS LIST

Thank you for purchasing our product, please save these instructions. Please do not perform or attempt any customizing, adjustments, repair or maintenance that is not described in this manual.

SPIRIT

Congratulations on your new elliptical trainer and welcome to the Spirit Fitness family!

Thank you for your purchase of this quality elliptical trainer from Spirit Fitness. Your new elliptical trainer was manufactured by one of the leading fitness manufacturers in the world and is backed by one of the most comprehensive warranties available. Through your dealer, Spirit Fitness will do all we can to make your ownership experience as pleasant as possible for many years to come. If not purchased direct from Spirit Fitness, the local dealership where you purchased this elliptical trainer is your administrator for all Spirit Fitness warranty and service needs. Their responsibility is to provide you with the technical knowledge and service personnel to make your experience more informed and any difficulties easier to remedy.

Please take a moment at this time to record the name of the dealer, their telephone number, and the date of purchase below to make any future, needed contact easy. We appreciate your support and we will always remember that you are the reason that we are in business.

Yours in Health,
Spirit Fitness

NAME OF DEALER _____

DEALER PHONE # _____

PURCHASE DATE _____

Record Your Serial Number

Please record the serial number of this fitness product in the space provided below.

Serial Number:

Register Your Purchase

The self-addressed product registration card must be completed in full and returned to Spirit Fitness. You can also go to www.spiritfitness.com/warranty under the Support tab to register online.

Important Safety Instructions

WARNING

When using an electrical appliance, basic precautions should always be followed, including the following: Read all instructions before using this appliance.

DANGER - To reduce the risk of electric shock: Always unplug this appliance from the electrical outlet immediately after using and before cleaning.

WARNING - To reduce the risk of burns, fire, electric shock, or injury to persons, install the elliptical on a flat level surface with access to a 115-volt, 15-amp grounded outlet with only the elliptical plugged into the circuit.

DO NOT USE AN EXTENSION CORD UNLESS IT IS A 18AWG OR BETTER, WITH ONLY ONE OUTLET ON THE END:

- To reduce the risk of burns, fire electric shock, or injury to persons:
- An appliance should never be left unattended when plugged in. Unplug from outlet when not in use, and before putting on or taking off parts.
- Do not operate under blanket or pillow. Excessive heating can occur and cause fire, electric shock, or injury to persons.
- Close supervision is necessary when this appliance is used by, on, or near children, invalids, or disabled persons.
- Use this appliance only for its intended use as described in this manual. Do not use attachments not

recommended by the manufacturer.

- Never operate this appliance if it has a damaged cord or plug, if it is not working properly, if it has been dropped or damaged, or dropped into water. Return the appliance to a service center for examination and repair.
- Do not carry this appliance by supply cord or use cord as a handle.
- Keep the cord away from heated surfaces.
- Never operate the appliance with the air openings blocked. Keep the air openings free of lint, hair, and the like.
- Never drop or insert any object into any opening.
- Do not use outdoors.
- Do not operate where aerosol (spray) products are being used or where oxygen is being administered.
- Connect this appliance to a properly grounded outlet only.
- The appliance is intended for household use.
- This exercise equipment is not intended for use by persons with reduced physical, sensory or mental capabilities, or lack of experience and knowledge.
- Keep children under the age of 13 away from this machine.

SAVE THESE INSTRUCTIONS - THINK SAFETY!

Fitness Equipment Safety Instructions

To disconnect turn all controls to the off position, then remove the plug from the outlet.

- Do not operate equipment on deeply padded, plush or shag carpet. Damage to both carpet and equipment may result.
- Before beginning this or any exercise program, consult a physician. This is especially important for persons over the age of 35 or persons with pre-existing health conditions.
- Do not attempt to use your equipment for any purpose other than for the purpose it is intended.
- Keep hands away from all moving parts.
- The pulse sensors are not medical devices. Their purpose is to provide you with an approximate measurement in relation to your target heart rate. Use of a chest transmitter strap (sold separately) is a much more accurate method of heart rate analysis. Various factors, including the user's movement, may affect the accuracy of heart rate readings. The pulse sensors are intended only as exercise aids in determining heart rate trends in general.
- Wear proper shoes. High heels, dress shoes, sandals or bare feet are not suitable for use on your equipment. Quality athletic shoes are recommended to avoid leg fatigue.

Failure to follow all guidelines may compromise the effectiveness of the exercise experience, expose yourself (and possibly others) to injury, and reduce the longevity of the equipment.

 **WARNING:** This product can expose you to chemicals including Toluene and Acrylamide which are known to the State of California to cause cancer and birth defects or other reproductive harm.

For more information go to www.P65Warnings.ca.gov

Important Electrical Instructions

 **WARNING**

NEVER remove any cover without first disconnecting AC power. If voltage varies by ten percent (10%) or more, the performance of your Elliptical may be affected. Such conditions are not covered under your warranty. If you suspect the voltage is low, contact your local power company or a licensed electrician for proper testing.

NEVER expose this elliptical to rain or moisture. This product is **NOT** designed for use outdoors, near a pool or spa, or in any other high humidity environment. The operating temperature specification is 40 to 120 degrees Fahrenheit, and humidity is 95% non-condensing (no water drops forming on surfaces).

Circuit Breakers: Some circuit breakers used in homes are not rated for high inrush currents that can occur when an elliptical is first turned on or even during use. If your elliptical is tripping the house circuit breaker (even though it is the proper current rating) but the circuit breaker on the elliptical itself does not trip, you will need to replace the home breaker with a high inrush type. This is not a warranty defect. This is a condition we as a manufacture have no ability to control. This part is available through most electrical supply stores. *Examples: Grainger part # 1D237, or available online at www.squared.com part #QO120HM.* The electrical outlet used should have a dedicated 15 amp circuit breaker.

Grounding Instructions

This product must be grounded. If the your equipment should malfunction or breakdown, grounding provides a path of least resistance for electric current, reducing the risk of electric shock. This product is equipped with a cord having an equipment-grounding plug. The plug must be plugged into an appropriate outlet that is properly installed and grounded in accordance with all local codes and ordinances.

DANGER - Improper connection of the equipment-grounding conductor can result in a risk of electric shock. Check with a qualified electrician or serviceman if you are in doubt as to whether the product is properly grounded. Do not modify the plug provided with the product if it will not fit the outlet; have a proper outlet installed by a qualified electrician.

This product is for use on a nominal 110-volt/15 amp dedicated circuit, and has a grounding plug that looks like the plug illustrated below. A temporary adapter that looks like the adapter illustrated below may be used to connect this plug to a 2-pole receptacle as shown below if a properly grounded outlet is not available. The temporary adapter should be used only until a properly grounded outlet, (shown below) can be installed by a qualified electrician. The green colored rigid ear-lug, or the like, extending from the adapter, must be connected to a permanent ground such as a properly grounded outlet box cover. Whenever the adapter is used, it must be held in place by a metal screw.

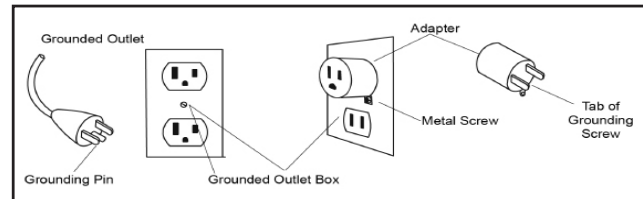

Important Operation Instructions

- **NEVER** operate this elliptical trainer without reading and completely understanding the results of any operational change you request from the computer.
- Understand that changes in resistance do not occur immediately. Set your desired resistance level on the computer console and release the adjustment key. The computer will obey the command gradually.
- **NEVER** use your elliptical during an electrical storm. Surges may occur in your household power supply that could damage elliptical components. Unplug the elliptical during an electrical storm as a precaution.
- Use caution while participating in other activities while pedaling on your elliptical trainer; such as watching television, reading, etc. These distractions may cause you to lose balance which may result in serious injury.
- Do not use excessive pressure on console control keys. They are precision set to function properly with little finger pressure.

XE395ENT PRE ASSEMBLY

UNPACKING

1. Cut the straps, then lift the box over the unit and unpack.
2. Carefully remove all parts from the carton and inspect for any damage or missing parts. If parts are damaged or missing, contact your dealer immediately.
3. Locate the hardware package. Remove the tools first. Remove the hardware for each step as needed to avoid confusion. The numbers in the instructions that are in parenthesis (#) are the item number from the assembly drawing for reference.

TOOLS INCLUDED:

- 13/14mm Wrench
- Phillips Head Screwdriver
- 12/14mm Wrench
- Combination M5 Allen Wrench & Phillips Head Screw Driver

PARTS INCLUDED:

- 1 Main Frame
- 1 Console Mast
- 1 Console Mast Cover
- 2 Swing Arms
- 2 Connecting Arms
- 6 Levelers
- 1 Console
- 2 Foot Pedals
- 1 Power Cord
- 1 Audio Cable
- 2 Transport Wheels
- 1 Hardware Kit

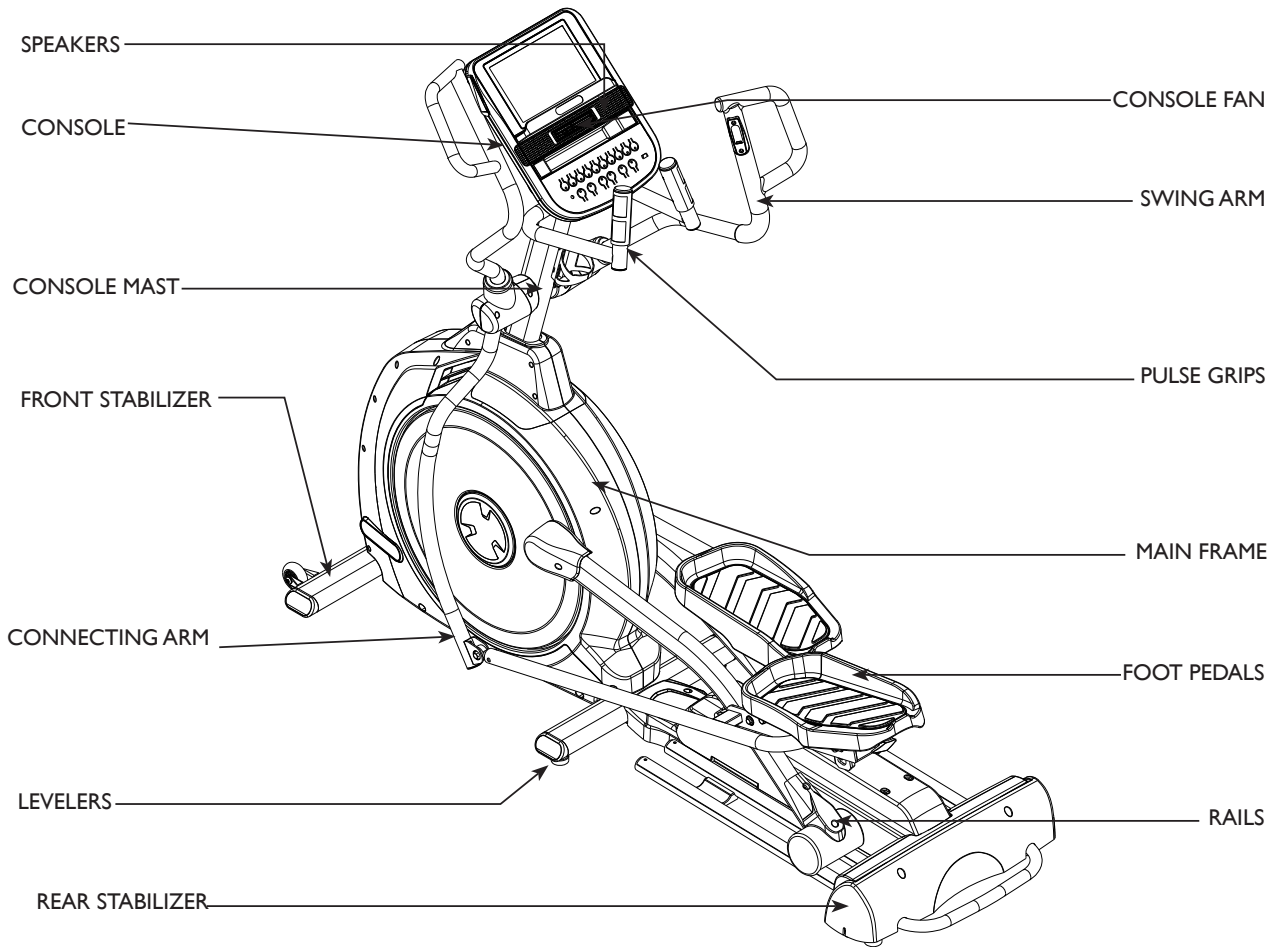

XE395ENT STEP ONE-A

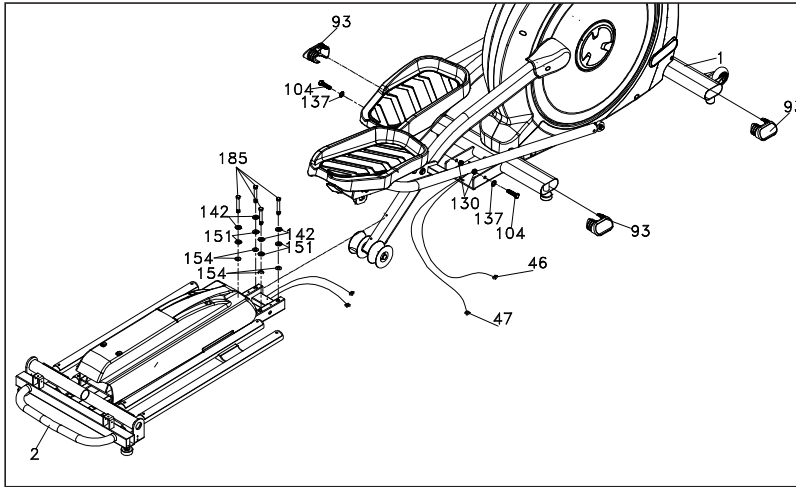

HARDWARE FOR STEP I				
PART	TYPE	DESCRIPTION	QTY	
104	HEX HEAD BOLT	3/8" X UNC16 X 1-1/2"	2	
130	NYLOC NUT	3/8" X 7T	2	
137	FLAT WASHER	3/8" x Ø19 x 1.5T	2	
142	FLAT WASHER	5/16" X 20 X 1.5T	4	
151	SPLIT WASHER	8 X 1.5T (5/16" X 1.5T)	4	
154	STAR WASHER	5/16"	4	
185	HEX HEAD BOLT	5/16" X 2 - 1/4"	4	

1. Gather **HARDWARE FOR STEP I**.
2. Slide the **INCLINE RAIL ASSEMBLY (2)** into the U channel of the **MAIN FRAME (1)**. Be very careful not to damage the wires that exit each part.
3. Connect the **INCLINE RAIL ASSEMBLY (2)** horizontally to the U channel of the **MAIN FRAME (1)** with 2 **HEX HEAD BOLTS (104)**, 2 **FLAT WASHERS (137)**, and 2 **NYLOC NUTS (130)**. Secure it vertically with 4 **HEX HEAD BOLTS (185)**, 4 **SPLIT WASHERS (142)**, 4 **FLAT WASHERS (151)**, and 4 **STAR WASHERS (154)**. Tighten using the **WRENCHES** provided (**155 & 158**).
4. Connect the **INCLINE MOTOR WIRES (46 & 47)** to the wiring harness & black wire that exits the **INCLINE RAIL ASSEMBLY (2)**. Push the excess cable inside the U channel.

XE395ENT STEP ONE-B

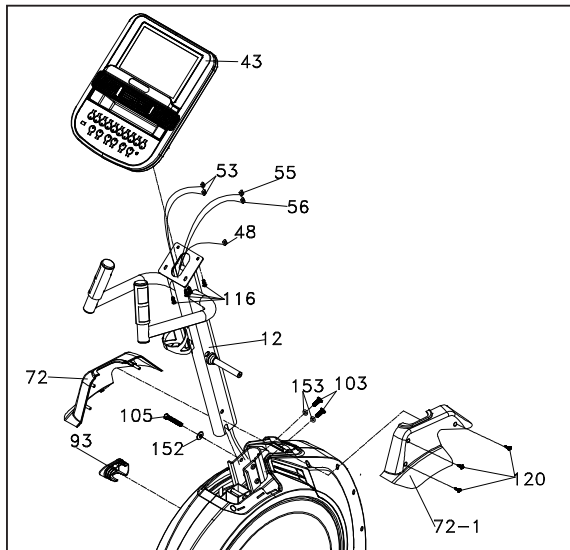

1. Gather **HARDWARE FOR STEP 1-B**.
2. Locate the **CONSOLE MAST (12)** and **CONSOLE MAST COVER (72)**; slide the Cover onto the mast as far as it will go. Make sure the **CONSOLE MAST COVER (72)** is facing the correct way. Tighten 3 **SHEET METAL SCREWS (120)** on the **CONSOLE MAST COVER (72/72-1)** with the **SCREW DRIVER (157)**.
3. At the top opening of the **MAIN FRAME (1)**, there is a **COMPUTER CABLE (48)** tied to a twist tie wire. Feed the twist tie wire and **COMPUTER CABLE (48)** into the bottom of the **CONSOLE MAST (12)** and out of the opening at the top.
4. Install the **CONSOLE MAST (12)** into the receiving bracket on the

HARDWARE FOR STEP I			
PART	TYPE	DESCRIPTION	QTY
103	HEX HEAD BOLT	3/8"X3/4"	2
105	HEX HEAD BOLT	3/8" X 2-1/4"	1
116	PHILLIPS HEAD SCREW	M5 X 10mm	4
120	SHEET METAL SCREW	3.5 X16mm	3
130	NYLOC NUT	3/8" X 7T	2
137	FLAT WASHER	3/8" x Ø19 x 1.5T	2
142	FLAT WASHER	5/16" X 20 X 1.5T	4
152	SPLIT WASHER	Ø10 x 2T	1
153	CURVED WASHER	Ø3/8" x 23 x 2T	2

top of the **MAIN FRAME (1)**. Be extremely careful not to pinch the cables between the tubing. If the cable gets pinched, this may affect the electrical functions of the console.

NOTE: There is one bolt already installed in the receiving bracket that will engage with the slot at the bottom of the Console Mast. This needs to be tightened last, after the three other Console Mast bolts.

5. Place a **SPLIT WASHER (152)** onto the **HEX HEAD BOLT (105)** and hand tighten through the left side of the Console Mast. Place a **CURVED WASHER (153)** onto each **HEX HEAD BOLT (103)** and thread both into the front of the Console Mast tube. Fasten these front bolts as tight as possible with the **WRENCH (155)**. Next firmly tighten the two left side bolts with the same wrench.
6. Connect the 2 **HAND PULSE CABLES (53)**, **RESISTANCE CABLE (55)**, and **INCLINE CABLE (56)** to the back of the **CONSOLE (43)**. Do not force the connectors; they will only fit one way and are different sizes to prevent confusion. Store the excessive cable in the **CONSOLE MAST TUBE (12)**.
7. Attach the **CONSOLE (43)** to the bracket of the Console Mast tube with 4 **PHILLIPS HEAD SCREWS (116)**. Tighten the screws with the **PHILLIPS HEAD SCREW DRIVER (157)**.
8. Insert 4 **OVAL END CAPS (93)** into the **MAIN FRAME (1)**.

XE395ENT STEP TWO

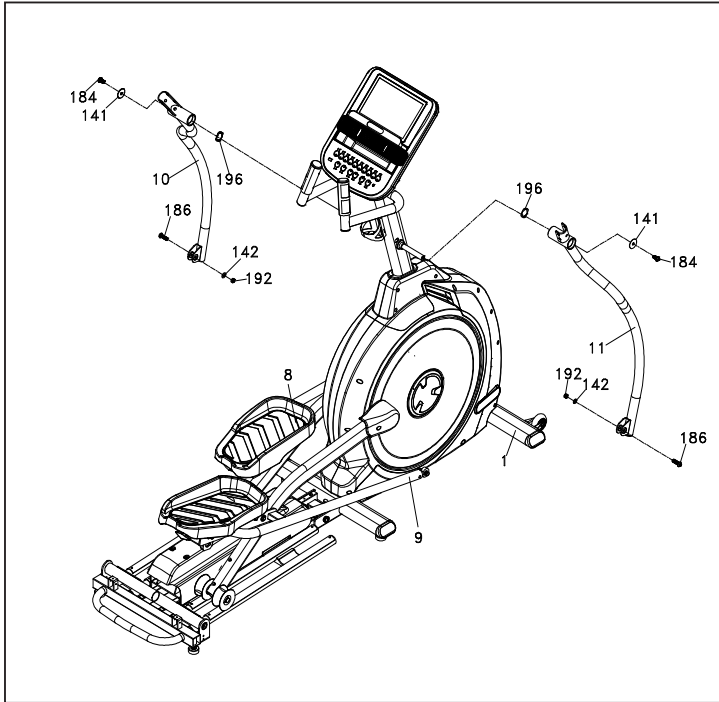

HARDWARE FOR STEP 2

PART	TYPE	DESCRIPTION	QTY
141	FLAT WASHER	5/16" X 23 X 1.5T	2
142	FLAT WASHER	5/16" X 20 X 1.5T	2
196	WAVE WASHER	Ø17	4
184	HEX HEAD BOLT	5/16" X 15L	2
186	HEX HEAD BOLT	5/16" X 1 - 1/4"	2
192	NYLOC NUT	5/16" X 9T	2

1. Gather **HARDWARE FOR STEP 2**.
2. Slide 2 **WAVE WASHERS (196)** onto each side of the Swing Arm Axle. Slide the **LOWER SWING ARMS (10 LEFT, 11 RIGHT)** onto the axles and secure with the 2 **BOLTS (184)** and **FLAT WASHERS (141)**. Do not force the Swing Arms onto the axle. They should slide on, but you may need to jiggle them to get them lined up properly. The Swing Arms have been previously installed at the factory so they do fit properly.
3. Remove the tie that holds the spacer in the rod end located at the end of the **RIGHT CONNECTING ARM (9)** and line up the rod end with the bracket at the bottom of the **LOWER RIGHT SWING ARM (11)**. Slide the **BOLT (186)** through the bracket of the Lower Swing Arm and then through the rod end and spacer. Install the **FLAT WASHER (142)** and **NYLOC NUT (192)** on the bolt and tighten as much as possible. Repeat this step for the left side. Tighten using the **WRENCHES (155 & 158)**.

XE395ENT STEP THREE

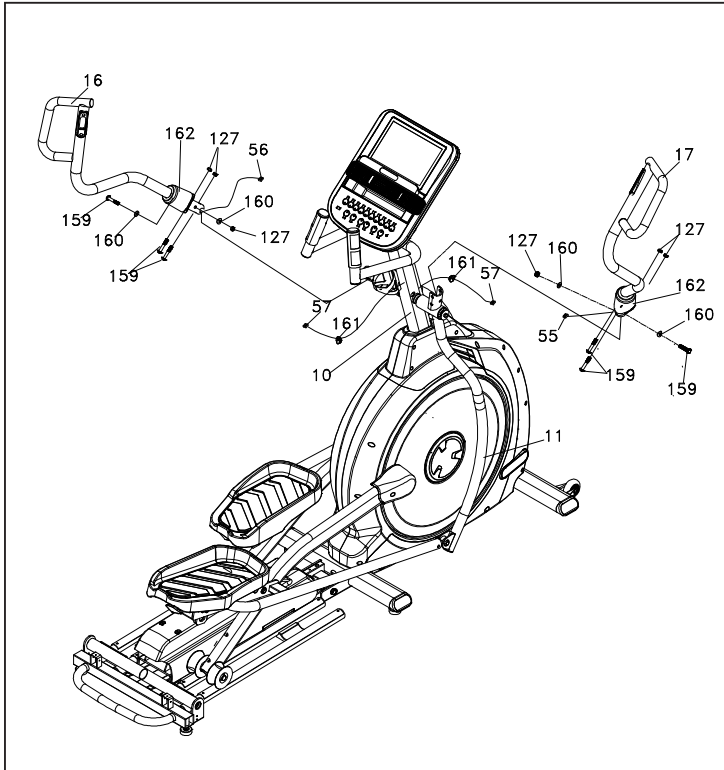

HARDWARE FOR STEP 3			
PART	TYPE	DESCRIPTION	QTY
127	NYLOC NUT	5/16" X 7T	6
159	HEX HEAD BOLT	5/16" X 1-3/4"	6
160	CURVED WASHER	8 X 23 X 1.5T	4
161	SWITCH WIRE CAP		2

1. Gather **HARDWARE FOR STEP 3**.
2. Slide the **RUBBER SLEEVE (162)** onto the **LEFT (16)** and **RIGHT (17)** Upper Swing Arms. Make sure the wide part is at the bottom.
3. Attach the **RESISTANCE CABLE (55)** from the **RIGHT UPPER SWING ARM (17)** and the **INCLINE CABLE (56)** from the **LEFT UPPER SWING ARM (16)** to 2 **HANDLE CABLES (57)** that exit the **CONSOLE MAST TUBE (12)**. Slide the 2 **SWITCH WIRE CAPS (161)** onto the wire with the wide side facing the Swing Arm.
4. Insert the **UPPER SWING ARM (17)** into the Lower Swing Arm. Fasten together with 3 **HEX HEAD BOLTS (159)**, 2 **CURVED WASHERS (160)**, and 3 **NYLOC NUTS (127)**.
5. Repeat steps from above on the left side.

XE395ENT STEP FOUR

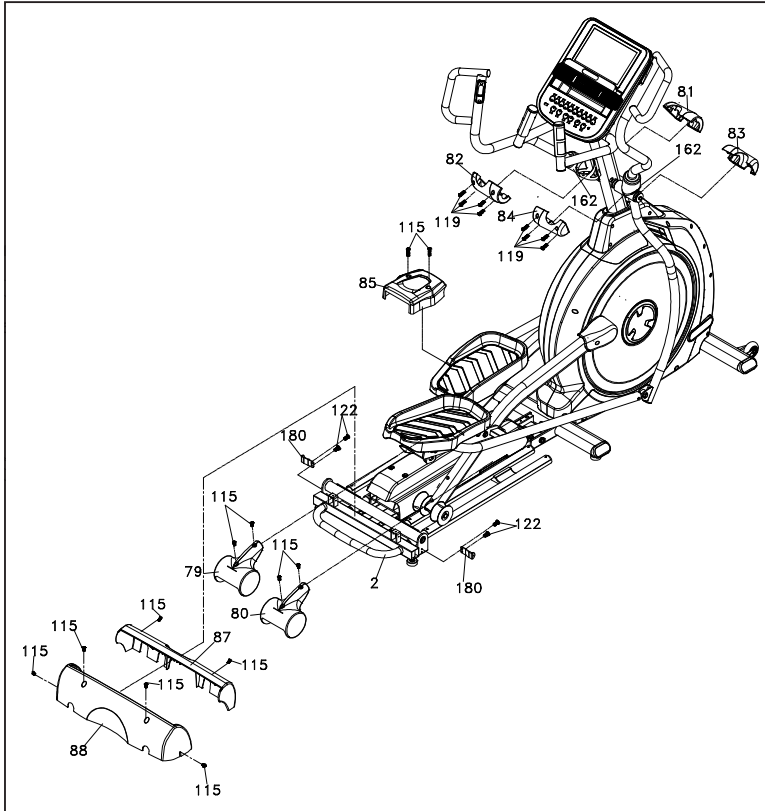

HARDWARE FOR STEP 4			
PART	TYPE	DESCRIPTION	QTY
115	PHILLIPS HEAD SCREW	M5 X 12MM	12
119	SHEET METAL SCREW	3.5 X 12MM	8
122	PHILLIPS HEAD SCREW	M6 X 10MM	4

1. Gather **HARDWARE FOR STEP 4**.
2. Fasten the 2 **WHEEL COVERS (79 & 80)** above the rollers with 4 **PHILLIPS HEAD SCREWS (115)**. Tighten with the **PHILLIPS HEAD SCREW DRIVER (157)**.
3. Plug the power cord into the machine and a grounded wall outlet. Turn the power switch on. Press the start button and elevate the incline to level 8. Attach the **COVER (85)** to the mid-stabilizer tube with 2 **PHILLIPS HEAD SCREWS (115)**. Tighten the screws with the **PHILLIPS HEAD SCREW DRIVER (157)**.
4. Install the **LEFT HANDLE BAR COVERS (81 & 82)** and **RIGHT HANDLE BAR COVERS (83 & 84)** over the Handle Bars axle connections with 4 **SHEET METAL SCREWS (119)** on each side. Tighten with the **PHILLIPS HEAD SCREW DRIVER (157)**.

Continued on next page...

5. Attach a **STEEL BRACKET (180)** to the Rear Stabilizer Tube on the left and right sides (with the single hole facing the rear), and secure them with 4 **PHILLIPS HEAD SCREWS (122)**. Tighten using the **PHILLIPS HEAD SCREW DRIVER (157)**.
6. Attach the front **REAR STABILIZER COVER (87)** to the **REAR STABILIZER TUBE (2)** with 2 **PHILLIPS HEAD SCREWS (115)**. Secure with the **PHILLIPS HEAD SCREW DRIVER (157)**. Attach the back **REAR STABILIZER COVER (88)** onto the Rear Stabilizer Tube with 4 **PHILLIPS HEAD SCREWS (115)**. Secure using the **PHILLIPS HEAD SCREW DRIVER (157)**.
7. Look closely at the four floor levelers underneath the middle and rear of the elliptical. If any of these aren't in contact with the floor, use the **WRENCH (109)** to loosen the top nut. Once the nut has been loosened, turn the rubber caster clockwise until it makes solid contact with the floor. Retighten the top nut to prevent it from moving.
8. Return the elevation to the flat position using the Incline down key.

XE395ENT CONSOLE OPERATION



POWER

When the power cord is connected to the elliptical, the console will automatically power up.

QUICK START

This is the quickest way to start a workout. After the console powers up you just press the **Start Workout** on the screen, or press the **START** key to begin. This will initiate Quick Start the Time will count up from zero and the workload may be adjusted manually by pressing the **Level Up/Down** keys.

There are 20 levels of resistance available for plenty of variety. The first 5 levels are very easy workloads and the changes between levels are set to a good progression for de-conditioned users. Levels 6-10 are more challenging, but the increases in resistance from one level to the next remain small. Levels 11-15 start getting tough as the levels jump more dramatically. Levels 16-20 are extremely hard and are good for short interval peaks and elite athletic training.

BASIC INFORMATION

The **Stop** key actually has several functions. Pressing the **Stop** key once during a program will pause the program for 5 minutes. If you need to get a drink, answer the phone or any of the many things that could interrupt your workout, this is a great feature. To resume your workout during Pause, just press the **Start** key. If the **Stop** key is pressed twice during a workout, the program will end and the console will display your Workout Summary (Total time, Avg. Speed, Avg. Power, Avg. HR, total Laps).

PROGRAMMING THE CONSOLE

Each of the programs can be customized with your personal information and changed to suit your needs. Some of the information asked for is necessary to ensure the readouts are correct. You will be asked for your Age and Weight. Entering your Age is necessary during the Heart Rate programs to ensure the correct settings are in the program for your Age. Otherwise the work settings could be too high or low for you. Entering your Weight aides in calculating a more correct Calorie reading. Although we cannot provide an exact calorie count, we do want to be as close as possible.

CALORIE NOTE: Calorie readings on every piece of exercise equipment, whether it is in a gym or at home, are not accurate and tend to vary widely. They are meant only as a guide to monitor your progress from workout to workout. The only way to measure your calorie burn accurately is in a clinical setting connected to a host of machines. This is because every person is different and burns calories at a different rate. Some good news is that you will continue to burn calories at an accelerated rate for at least an hour after you have finished exercising!

CHARGE PORTABLE DEVICES WITH USB PORT

You can charge your personal device during your workout using the fitness equipment's on-console USB port. To charge your mobile electronics make sure the fitness equipment power is on.

Step 1: Connect your USB charging cable (not included) to the USB Power Port and to your device.

Step 2: Check to make sure your device icon indicates it is charging.

NOTE:

- USB charging cable is not included, make sure compatible USB charging cable is being used.
- The USB port on the console is capable of powering USB devices. It provides up to 5Vdc/1.0 amp of power and meets USB 2.0 regulations. You will not be able to save your workout data to a USB via this port; it is used for charging purposes only.

WIFI SETUP

Once the console is powered on, connect to the available WiFi network either by pressing the Signal icon on the top right corner or from the SETTINGS menu on the bottom right corner. Without WiFi, saving workout data to the cloud, using apps and casting content will not work. If WiFi connection is not set up, please set data and time manually. If you change your mind later, you can always find WiFi settings in the bottom right corner on the screen.

Choose "Guest" user or create yourself a profile to get more personalized experience. Maximum of 9 profiles can be created. Learn more about profiles in "Profile".

SETTINGS

- Tap on **DISPLAY BRIGHTNESS** to adjust the brightness of the screen.
- Tap on **WIFI** for internet connection settings.
- Tap on **BLUETOOTH** to pair with the Bluetooth devices including the Bluetooth type of chest straps, earphones, or speakers.
- Tap on **SOFTWARE** to check the current software version or to update, if a new one is available. Press Update to upload and install the latest version. Be sure to be connected to the Internet.
- Tap on **DATE** or **TIME** to change the machine time settings. The time and date settings define the time information in the workout summary. Both 12 and 24 hours formats are available.
- Tap on **CHILD LOCK** to lock the screen.
- Tap on **UNITS** to switch between imperial and metric system.
- Tap on **DISPLAY MODE** to turn ON/OFF the screen.

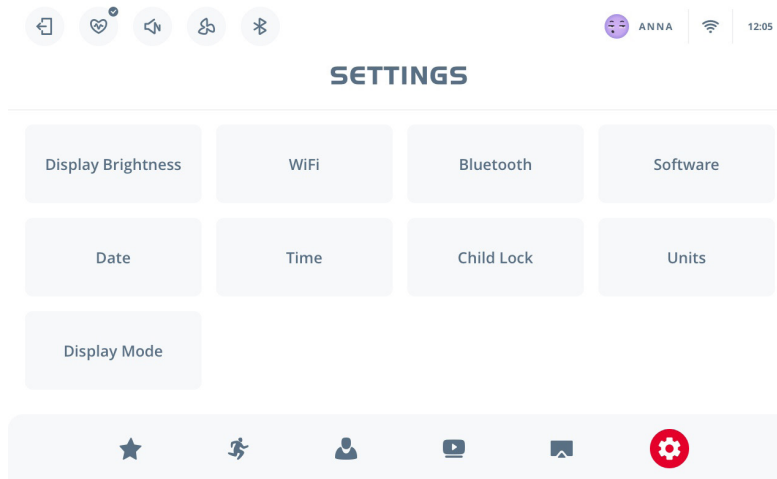

PROFILE

To create a new profile, press **+** button on the starting screen. If you already have a Spirit APP account, open the app and select **CONNECT TO MACHINE**. Then use your phone's camera to scan the QR code that appears on the screen. This action will not only upload your already existing personal info to the machine, but also link two profiles together, so your workout history will be fully displayed in the Spirit app. One Spirit app account cannot be linked to multiple profiles on one machine.

If you do not have a Spirit account, press the **I DON'T** button to continue and build one by filling in the form.

There are 3 tabs in the Profile section: **Info**, **History**, and **Favorites**. Creating a profile lets your machine remember your physical data, so you don't need to provide it every time you want to work out. Your personal data can be found in the **INFO** tab. To edit, tap on any information field and make changes, then press **Save**. If you haven't linked your Spirit account to the local machine profile, you can also do it here by pressing "Spirit Account" field.



Ten records of the latest activity can be found in **HISTORY** tab. Workout history only shows work-outs that were completed by the current user. Tap on the record preview for details. All the records are available in the Spirit app account, if the profile is linked to the Spirit app account. **FAVORITES** tab is where all the programs that were labeled as favorites by the current user can be seen and deleted.

Different users can choose different unit systems, select their personal favorite programs and save their own templates.

Navigation icons: Home, Heart, Speaker, Share, Bluetooth

Profile: ANNA | Signal strength | 12:05

Menu: INFO (selected), HISTORY, FAVORITES

 DELETE PROFILE	USERNAME Anna	HEIGHT 170 cm	AGE 31
	GENDER Female	WEIGHT 70.0 kg	SPIRIT ACCOUNT  EMAIL@GMAIL.COM



Bottom navigation: Star, Jogging, Profile (selected), Video, Messages, Settings

HOMESCREEN

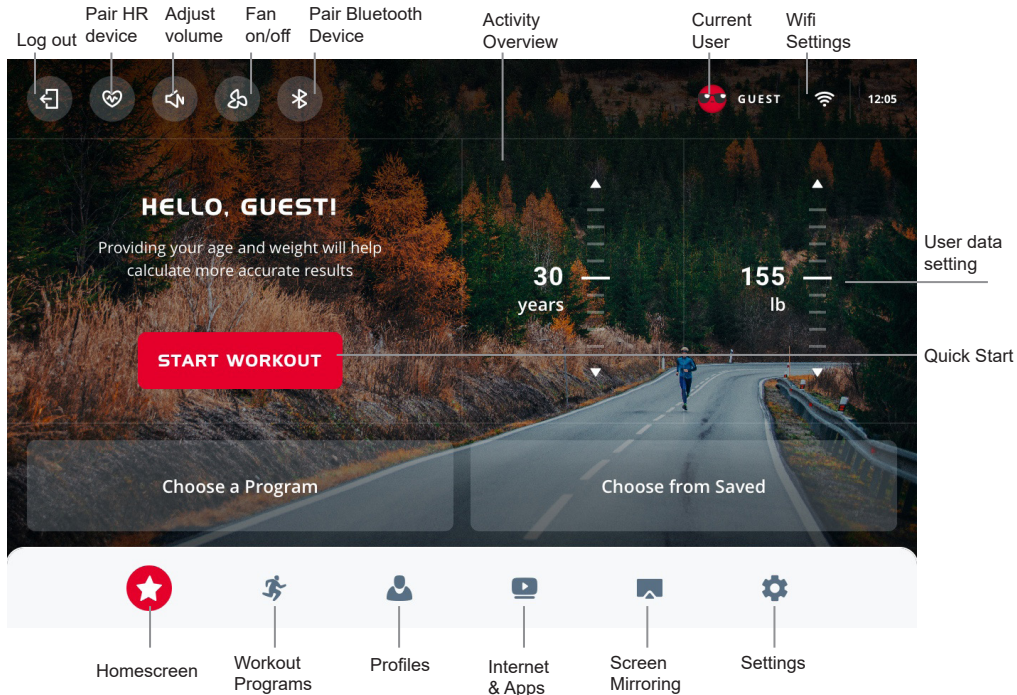
The Homescreen provides activity overview and suggests shortcuts to the training options. If in Guest mode, you can provide your physical data here, which will help the machine more accurately calculate your workout summary. Use scales or arrows to adjust your age and weight. Start Workout button starts the workout immediately.



INTERNET & APPS

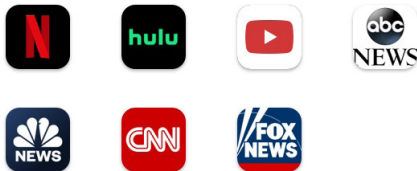

In this section there are a variety of third party apps to keep you entertained during your workout. To use them, make sure your machine is connected to WiFi (see page 21 for instructions). Then choose the app you want to use by clicking on it. Note that some apps may require a subscription to access. Press  to enter full screen mode. Press  to exit full screen mode. Press  to choose another app.

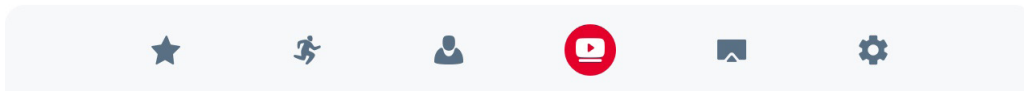

 WHEN CLOSING THE APP, YOU ARE NOT SIGNED OUT AUTOMATICALLY



SCREEN MIRRORING



To display various content from your smartphones or tablets on the machine console, open this section and follow the instructions provided, depending on whether you use an iOS or an Android device. Once the mirroring has started, press  to enter full screen mode. Press  to exit full screen mode.



IOS **ANDROID**

Connect your device to the same WiFi network as the equipment. Press the 'Screen Mirroring' button on your device, then select the SPIRIT device.

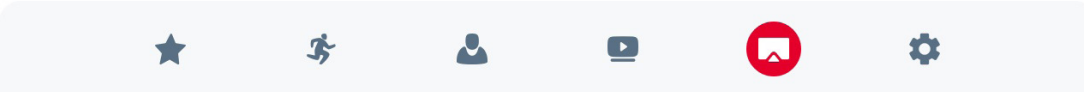
WIFI NAME: TP-LINK 40CF
(A STRONG CONNECTION IS REQUIRED)
DEVICE NAME: SPIRIT *MODEL*



WORKOUT VIEWS

Once the workout has started, after the short countdown the console will appear in its workout mode.

The panel on the left is fixed and shows your current **WORKOUT STATS**. More related stats can be revealed by pressing on the + icon. **LEVEL AND INCLINE CONTROLS** can be adjusted by tapping on arrows in the right panel. The icons on the top panel are the tools available during your workout: volume, fan and WiFi. When the workout is paused, you can also access HR device pairing settings.

The bottom panel is with 3 views from the left to the right:

- **GOAL VIEW** displays the parameter that defines your workout finish (for example, for profile programs it is time counting down; for distance programs it is distance left).
- **PROFILE VIEW** shows your workout profiles and your current position in them.
- **TRACK VIEW** helps to imagine yourself making laps on a 1/4 mile track and shows your progress depending on distance covered.

INTERNET and **SCREEN MIRRORING** work the same way as in non-workout mode. To pause or finish the workout, press Stop on the bottom right corner.

Goal View:



Profile View:



Track View

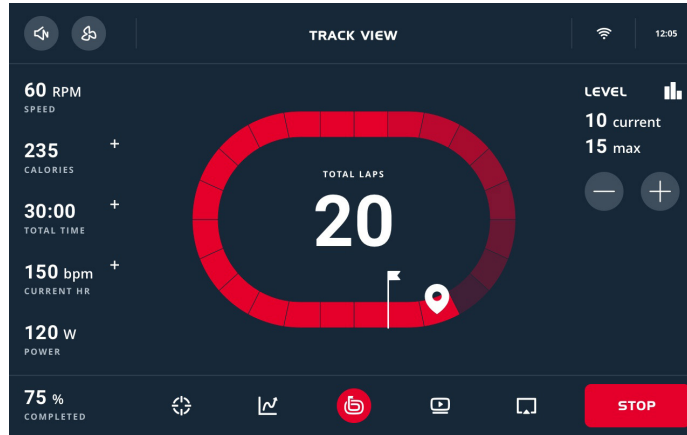

After the workout is finished, the workout summary will appear. Slide to the left to get more details or press **Done** to go back to the Home screen. You can also save the completed program as a template from here, if you press **Save** as button. The workout record will appear in History tab of the Profile section.

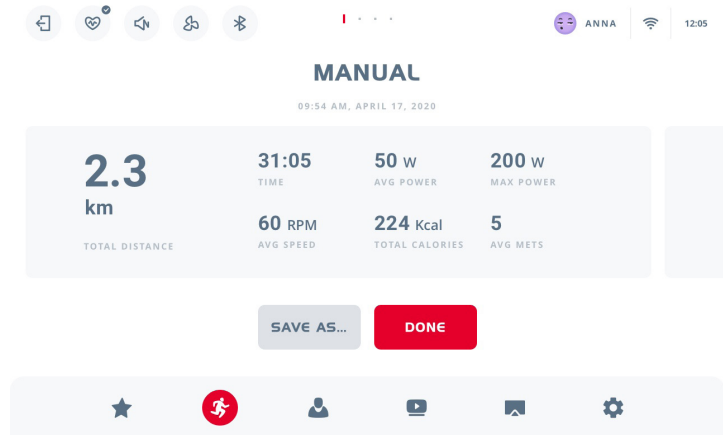

WORKOUT PROGRAMS

In this section, there are 2 program categories available: Programs (programs with predefined level and incline changing profiles) and Templates (regular programs, saved with your personal adjustments). Tap on the category names to switch between them.

To get more info on each program, tap on the program preview. In this view you can scroll to the side to see all the program descriptions of the selected category. Press **CHOOSE** to select and adjust a program.

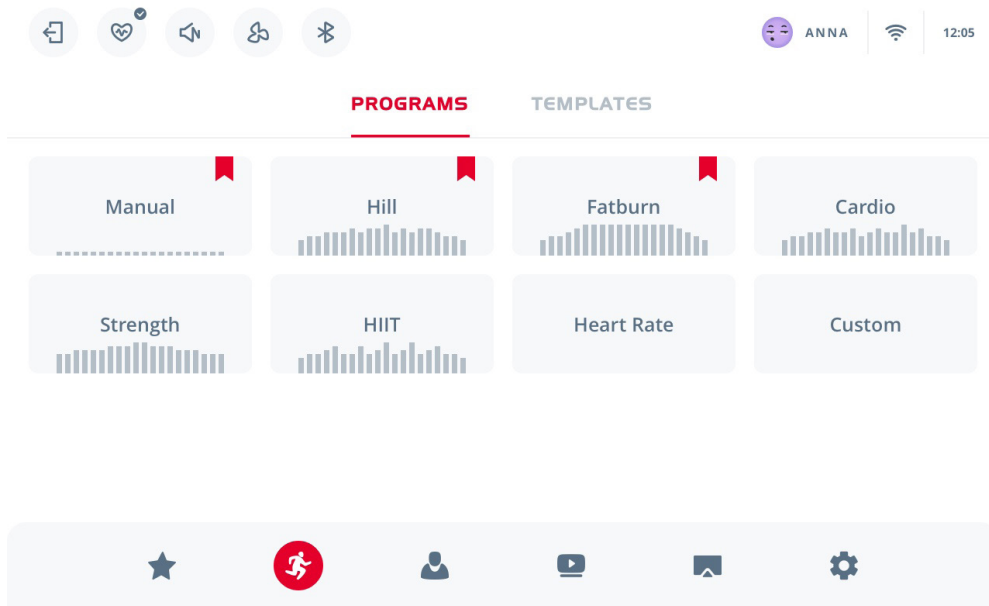

Any program can be labeled as FAVORITE.

Favorite programs appear on the Homescreen, so you can access them anytime you want.

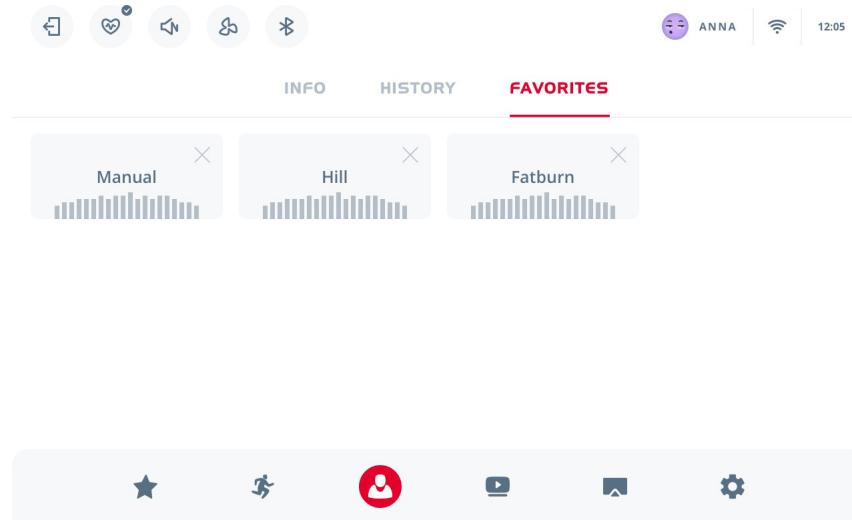

MANUAL program requires a time frame set before starting. Use the scale or arrows to adjust target time. Level and incline are adjusted manually while running. Press **START** to begin workout.

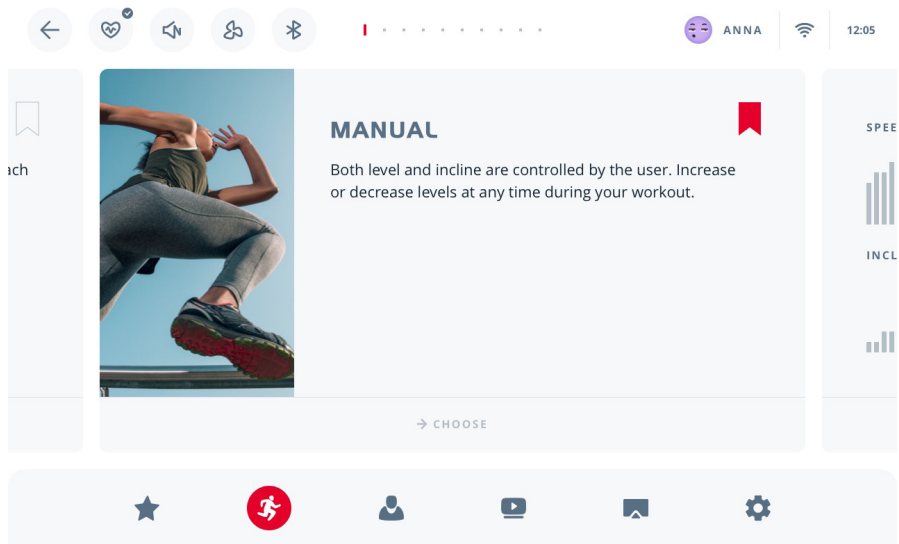

PRESET PROGRAMS

The elliptical has five different programs that have been designed for a variety of workouts. These five programs have factory preset work level profiles for achieving different goals.

HILL program follows a triangle or pyramid type of gradual progression from approximately 10% of maximum effort (the level that you chose before starting this program) up to a maximum effort which lasts for 10% of the total workout time, then a gradual regression of resistance back to approximately 10% of maximum effort. **Incline:** The pedal elevation is a more gradual and sustained progression. Maximum elevation is in the middle of the workout and lasts for 10% of the duration.

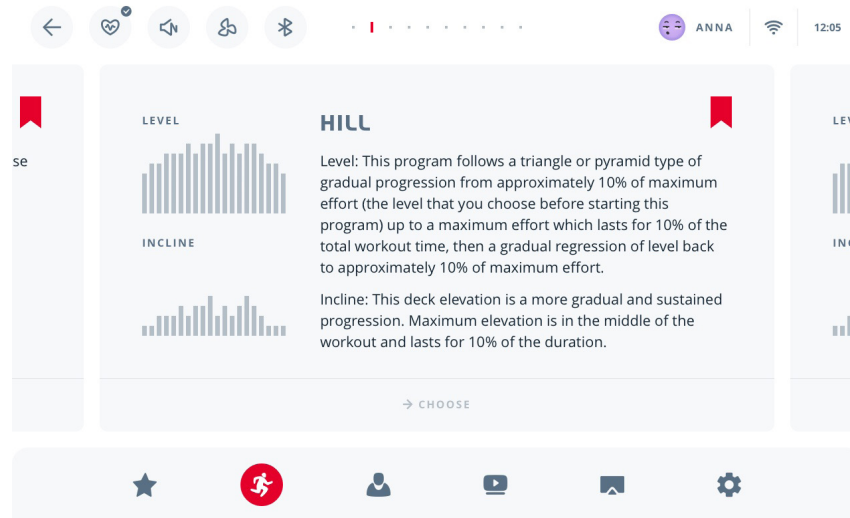

FAT BURN program follows a quick progression up to the maximum resistance level (default or user input level) that is sustained for 2/3 of the workout. This program will challenge your ability to sustain your energy output for an extended period of time. Incline: The pedal elevation is a quick and sustained progression up to the maximum value (default or user input) for 90% of the workout duration.

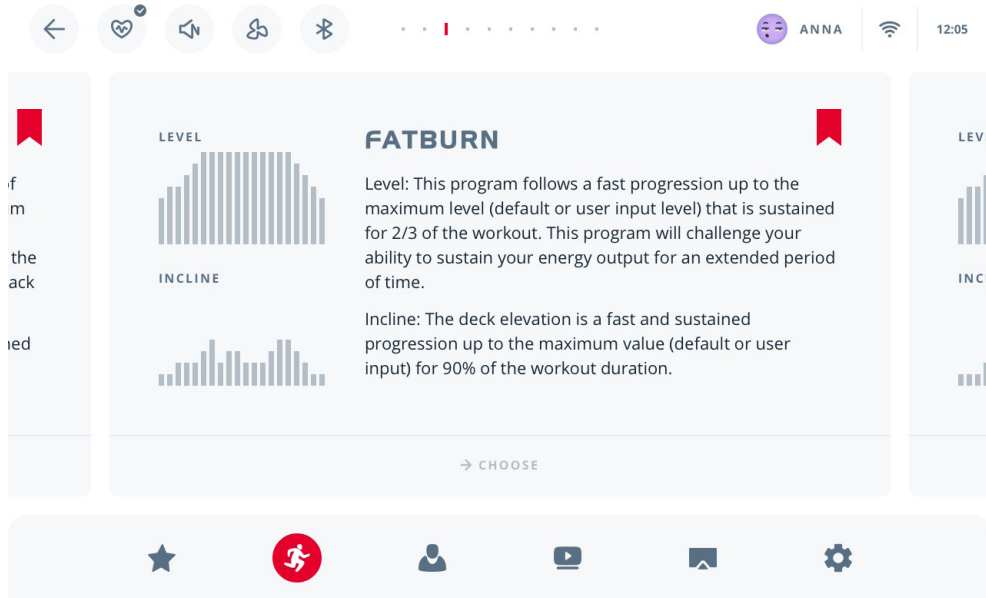

CARDIO program presents a quick progression up to near maximum resistance level (default or user input level). It has slight fluctuations up and down to allow your heart rate to elevate, and then recover repeatedly, before beginning a quick cool down. This will build up your heart muscle and increase blood flow and lung capacity. Incline: The elevation in this program is moderate. There are several elevation spikes at different points of the workout. Segments 4, 9, and 14 are maximum elevation for this program.

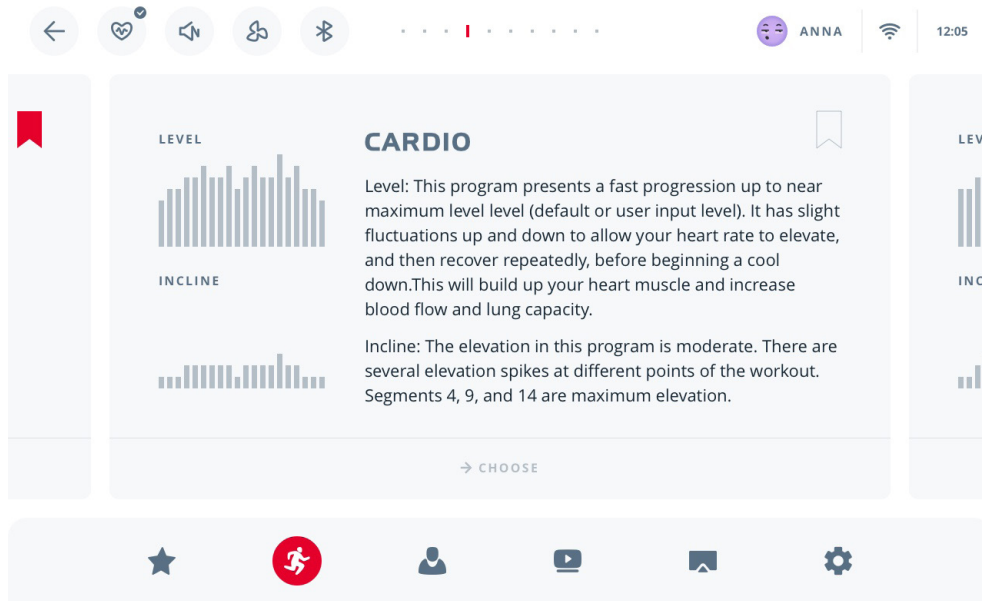

STRENGTH program has a gradual progression of resistance up to 100% of maximum effort that is sustained for 25% of workout duration. This will help build strength and muscular endurance in the lower body and glutes. A brief cool down follows. Incline: There is a quick climb to a moderate, sustained elevation that lasts the majority of the workout length.

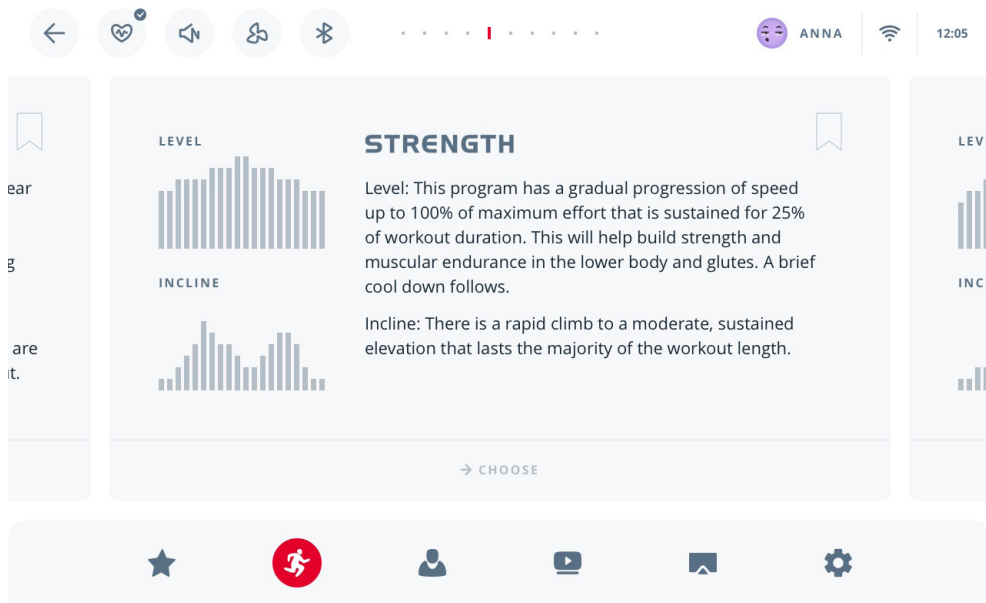

HIIT, OR HIGH INTENSITY INTERVAL Training, program takes you through high levels of intensity followed by recovery periods of low intensity. This program utilizes and develops your “Fast Twitch” muscle fibers which are used when performing tasks that are intense and short in duration. These deplete your oxygen level and spike your heart rate, followed by periods of recovery and heart rate drop to replenish oxygen. Your cardiovascular system gets programmed to use oxygen more efficiently. Incline: This program will spike similar to the speed profile, but in different segments (columns); this means that all of your lower extremity muscles will be equally challenged throughout this program. The incline alternates between 25 & 65 % of maximum elevation.

The screenshot shows a mobile application interface for selecting a HIIT program. At the top, there is a navigation bar with icons for back, heart, volume, share, and a red dot. The main content area features a central card for the 'HIIT' program. This card includes two bar charts: 'LEVEL' and 'INCLINE'. The 'LEVEL' chart shows a series of vertical bars of varying heights, representing intensity levels over time. The 'INCLINE' chart shows a similar pattern but with more pronounced peaks and troughs, indicating alternating elevation levels. To the right of these charts, the text describes the HIIT program: 'Level: This program takes you through high levels of intensity followed by recovery periods of low intensity. This program utilizes and develops your “Fast Twitch” muscle fibers which are used when performing tasks that are intense and short in duration.' Below this, it explains the incline: 'Incline: elevation will spike in different segments; this means that all of your lower extremity muscles will be equally challenged throughout this program.' At the bottom of the card is a '→ CHOOSE' button. The app's bottom navigation bar contains icons for a star, a running person (highlighted in red), a person icon, a video icon, a messages icon, and a settings icon. The top right corner shows the user's name 'ANNA', a Wi-Fi signal, and the time '12:05'.

CUSTOM program allows you to set the level and incline variations within a program profile. Once the profile is defined, choose target time and maximum level, so the intensity adapts accordingly. Every program can be saved as a template once adjusted or once completed. Press Save as to save the program with the current settings. You can manage saved programs in TEMPLATES. To delete a template, tap on it, then press Delete in the top right corner. Maximum of 12 template programs can be stored. A Template program is only available to a user who created it.

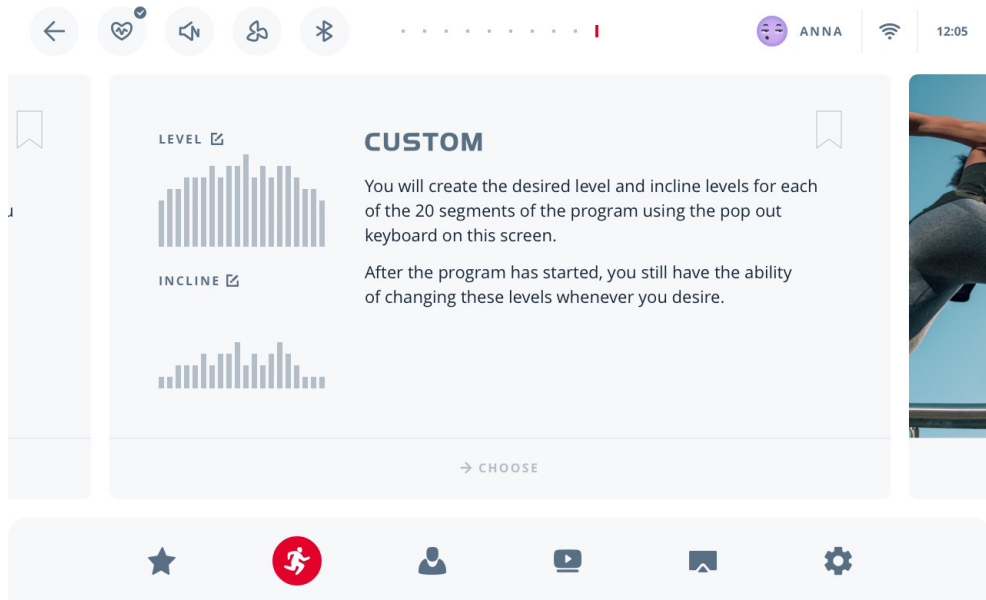

HEART RATE PROGRAMS

Note: You must wear a heart rate transmitter strap for these programs.

Both programs operate the same, the only difference is that HR1 is set to 60% and HR2 is set to 80% of the maximum heart rate. They both are programmed the same way. To start an HR program select the HR1 or HR2 program, then the Next button and follow the directions on the screen.

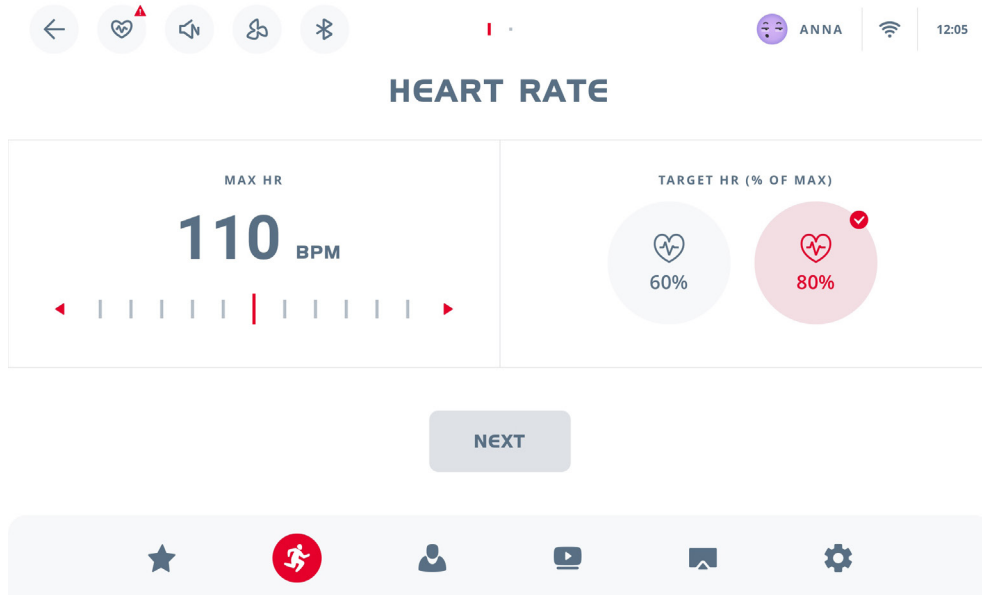

Heart Rate Programs

The old motto, “no pain, no gain”, is a myth that has been overpowered by the benefits of exercising comfortably. A great deal of this success has been promoted by the use of heart rate monitors. With the proper use of a heart rate monitor, many people find that their usual choice of exercise intensity was either too high or too low and exercise is much more enjoyable by maintaining their heart rate in the desired benefit range.

To determine the benefit range in which you wish to train, you must first determine your Maximum Heart Rate. This can be accomplished by using the following formula: 220 minus your age. This will give you the Maximum Heart Rate (MHR) for someone of your age. To determine the effective heart rate range for specific goals you simply calculate a percentage of your MHR. Your Heart rate training zone is 50% to 90% of your maximum heart rate. 60% of your MHR is the recommended for burning fat while 80% is recommended for strengthening the cardio vascular system. This 60% to 80% is the zone to stay in for maximum benefit.

For someone who is 40 years old their
target heart rate zone is calculated:

$$220 - 40 = 180 \text{ (maximum heart rate)}$$

$$180 \times .6 = 108 \text{ beats per minute (60\% of maximum)}$$

$$180 \times .8 = 144 \text{ beats per minute (80\% of maximum)}$$

So for a 40 year old the training zone would
be 108 to 144 beats per minute.

If you enter your age during programming the console will perform this calculation automatically. Entering your age is used for the Heart Rate programs. After calculating your MHR you can decide upon which goal you would like to pursue.

The two most popular reasons for, or goals, of exercise are cardiovascular fitness (training for the heart and lungs) and weight control. The black columns on the chart above represent the MHR for a person whose age is listed at the bottom of each column. The training heart rate, for either cardiovascular fitness or weight loss, is represented by two different lines that cut diagonally through the chart. A definition of the lines' goal is in the bottom left-hand corner of the chart. If your goal is cardiovascular fitness or if it is weight loss, it can be achieved by training at 80% or 60%, respectively, of your MHR on a schedule approved by your physician. Consult your physician before participating in any exercise program.

With all Spirit Fitness Heart Rate programs you may use the heart rate monitor feature without using the Heart Rate program. This function can be used during manual mode or during any of the nine different programs. The Heart Rate program automatically controls resistance at the pedals.

Rate of Perceived Exertion

Heart rate is important but listening to your body also has a lot of advantages. There are more variables involved in how hard you should workout than just heart rate. Your stress level, physical health, emotional health, temperature, humidity, the time of day, the last time you ate and what you ate, all contribute to the intensity at which you should workout. If you listen to your body, it will tell you all of these things.

The rate of perceived exertion (RPE), also known as the Borg scale, was developed by Swedish physiologist G.A.V. Borg.

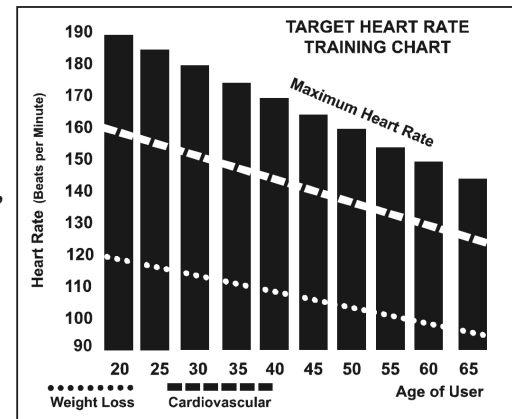

This scale rates exercise intensity from 6 to 20 depending upon how you feel or the perception of your effort.

The scale is as follows:

Rating Perception of Effort

6 Minimal	10 Very light +	14 Somewhat hard +	18 Very hard +
7 Very,very light	11 Fairly light	15 Hard	19 Very,very hard
8 Very,very light +	12 Comfortable	16 Hard +	20 Maximal
9 Very light	13 Somewhat hard	17 Very hard	

You can get an approximate heart rate level for each rating by simply adding a zero to each rating. For example a rating of 12 will result in an approximate heart rate of 120 beats per minute. Your RPE will vary depending up the factors discussed earlier. That is the major benefit of this type of training. If your body is strong and rested, you will feel strong and your pace will feel easier. When your body is in this condition, you are able to train harder and the RPE will support this. If you are feeling tired and sluggish, it is because your body needs a break. In this condition, your pace will feel harder. Again, this will show up in your RPE and you will train at the proper level for that day.

Wearing The Chest Strap

1. Attach the transmitter to the elastic strap using the interlocking key.
2. Adjust the strap as tightly as possible as long as the strap is not too tight to remain comfortable.
3. Position the transmitter with the logo centered in the middle of your torso facing away from your chest (some people must position the transmitter slightly left of center). Attach the final end of the elastic strap by inserting the round end and, using the locking parts, secure the transmitter and strap around your chest.
4. Position the transmitter directly below the pectoral muscles.

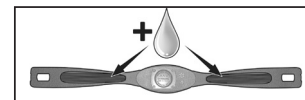
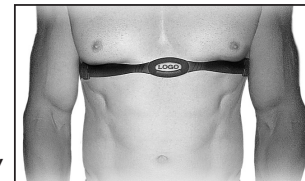

5. Sweat is the best conductor to measure very minute heart beat electrical signals. However, plain water can also be used to pre-wet the electrodes (2 ribbed oval areas on the reverse side of the belt and both sides of the transmitter). It's also recommended that you wear the transmitter strap a few minutes before your work out. Some users, because of body chemistry, have a more difficult time in achieving a strong, steady signal at the beginning. After "warming up", this problem lessens.
6. Your workout must be within range - distance between transmitter/receiver – to achieve a strong steady signal. The length of range may vary somewhat but generally stay close enough to the console to maintain good, strong, reliable readings. Wearing the transmitter directly on bare skin assures you of proper operation. If you wish, you may wear the transmitter over a shirt. To do so, wet the areas of the shirt that the electrodes will rest upon.

Note: The transmitter is automatically activated when it detects activity from the user's heart. Additionally, it automatically deactivates when it does not receive any activity. Although the transmitter is water resistant, moisture can have the effect of creating false signals, so you should take precautions to completely dry the transmitter after use to prolong battery life (estimated transmitter battery life is 2500 hours). The replacement battery is Panasonic CR2032.

ERRATIC OPERATION

Caution! Do not use this elliptical trainer for Heart Rate programs unless a steady, solid Actual Heart Rate value is being displayed. High, wild, random numbers being displayed indicate a problem.

Areas to look for interference which may cause erratic heart rate:

1. Microwave ovens, TV's, small appliances, etc.
2. Fluorescent lights.
3. Some household security systems.
4. Perimeter fence for a pet.
5. Some people have problems with the transmitter picking up a signal from their skin. If you have problems try

wearing the transmitter upside down. Normally the transmitter will be oriented so the Spirit Fitness logo is right side up.

6. The antenna that picks up your heart rate is very sensitive. If there is an outside noise source, turning the whole machine 90 degrees may de-tune the interference.
7. Another Individual wearing a transmitter within 3' of your machine's console.

If you continue to experience problems contact your dealer

Using the Spirit+ App

In order to help you achieve your exercise goals, your new exercise machine comes equipped with a Bluetooth® transceiver that will allow it to interact with selected phones or tablet computers via the Spirit+ App.

Scan the QR code on the screen or search Spirit+ in the App Store or Google Play to download.

The Spirit+ App also allows you to sync your workout data with one of many fitness cloud sites.

Syncing the App with your exercise machine:

1. Download the App.
2. Open the App on your device (phone or tablet) and make sure Bluetooth® is enabled on your device (phone or tablet).
3. In the App click the icon in the top right corner to search for your Spirit equipment (shown right).
4. After the equipment is detected, click the row on which the equipment is to connect Spirit+ app. Then click the “Display” icon to start the sync process.
5. When your workout is complete, the data is automatically saved and uploaded to a cloud site.

**Note: Your device will need to be running on a minimum operating system of iOS 13 or Android 8.0 for the Spirit+ App to operate properly.*



GENERAL MAINTENANCE

1. Wipe down all areas in the sweat path with a damp cloth after each workout.
2. If a squeak, thump, clicking or rough feeling develops the main cause is most likely one of several reasons:
 - I. The hardware was not sufficiently tightened during assembly. All bolts that were installed during assembly need to be tightened as much as possible. It may be necessary to use a larger wrench than the one provided if you cannot tighten the bolts sufficiently. I cannot stress this point enough; 90% of calls to the service department for noise issues can be traced to loose hardware.
 - II. Dirt build-up on the rear rails and polyurethane wheels are also a source of noise. Noise from build-up on the rails can cause a thumping sound that you would swear is coming from inside the main body of the machine because noise travels, and is amplified, in the tubing of the frame. Clean the rails and wheels with a lint free cloth and rubbing alcohol. Stubborn build-up can be removed with your thumbnail or a nonmetallic scraper, like the back edge of a plastic knife. After cleaning, apply a small amount of lubricant on the rails with your fingers or a lint free cloth. You only need a thin coat of lubrication, wipe off any excess.
 - III. The crank arm nut needs to be retightened
 - IV. If squeaks or other noises persist, check that the unit is properly leveled. There are 2 leveling pads on the bottom of the rear stabilizer, use a 14mm wrench (or adjustable wrench) to adjust the levelers.

Elliptical Trainer Warranty - Effective February 25, 2021

Spirit Fitness, Inc. (Spirit Fitness) warrants all its elliptical trainer parts for a period of time listed below from the date of retail sale, as determined by sale receipt, or in the absence of a sales receipt eighteen (18) months from the original factory shipping date. Spirit Fitness' responsibilities include providing new or remanufactured parts, at Spirit Fitness' option, and technical support to our independent dealers and servicing organizations. In the absence of a dealer or service organization, these warranties will be administered by Spirit Fitness directly to a consumer. The warranty period applies to the following components:

Warranty	Frame	Brake	Parts	Console	Labor
Residential	Lifetime	Lifetime	10 Years	2 Years	1 Year

NORMAL RESPONSIBILITIES OF THE CONSUMER

This warranty applies only to products in ordinary household use (see restrictions above), and the consumer/facility is responsible for the items listed below:

1. The warranty registration card must be completed and returned to the address listed on the card within 10 days of the original purchase to validate the manufacturer's limited warranty.
2. Proper use of the elliptical trainer in accordance with the instructions provided in this manual
3. Proper installation in accordance with instructions provided with the elliptical trainer and with all local electric codes.
4. Expenses for making the elliptical trainer accessible for servicing, including any item that was not part of the elliptical trainer at the time it was shipped from the factory.
5. Damages to the elliptical trainer finish during shipping, installation or following installation.
6. Routine maintenance of this unit as specified in this manual.

EXCLUSIONS

This warranty does not cover the following:

1. CONSEQUENTIAL, COLLATERAL, OR INCIDENTAL DAMAGES SUCH AS PROPERTY DAMAGE AND INCIDENTAL EXPENSES RESULTING FROM ANY BREACH OF THIS WRITTEN OR ANY IMPLIED WARRANTY.
Note: Some states do not allow the exclusion or limitation of incidental or consequential damages, so this limitation or exclusion may not apply to you.
2. Service call reimbursement to the consumer. Service call reimbursement to the dealer that does not involve malfunction or defects in workmanship or material, for units that are beyond the warranty period, for units that are beyond the service call reimbursement period, for elliptical trainer not requiring component replacement, or elliptical trainer not in ordinary household or light commercial use.
3. Damages caused by services performed by persons other than authorized Spirit Fitness service companies; use of parts other than original Spirit Fitness parts; or external causes such as corrosion, discoloration of paint or plastic, alterations, modifications, abuse, misuse, accident, improper maintenance, inadequate power supply, or acts of God.
4. Products with original serial numbers that have been removed or altered.

5. Products that have been: sold, transferred, bartered, or given to a third party.
6. Products that do not have a warranty registration card on file at Spirit Fitness. Spirit Fitness reserves the right to request proof of purchase if no warranty record exists for the product.
7. THIS WARRANTY IS EXPRESSLY IN LIEU OF ALL OTHER WARRANTIES EXPRESSED OR IMPLIED, INCLUDING THE WARRANTIES OF MERCHANTABILITY AND/OR FITNESS FOR A PARTICULAR PURPOSE.
8. Product use in any environment other than a residential setting or non-dues paying facility with 5 hours use or less per day.
9. Warranties outside of the United States may vary. Please contact your local dealer for details.

SERVICE

Keep your bill of sale. Twelve (12) months from the date on the bill of sale or eighteen (18) months from the date of factory shipping as determined by the serial number establishes the labor warranty period should service be required. If service is performed, it is in your best interest to obtain and keep all receipts. This written warranty gives you specific legal rights. You may also have other rights that vary from state to state. Service under this warranty must be obtained by following these steps, in order:

1. Contact your selling authorized Spirit Fitness dealer. OR
2. Contact your local authorized Spirit Fitness service organization.
3. If there is a question as to where to obtain service, contact our service department at (870) 935-1107.
4. Spirit Fitness' obligation under this warranty is limited to repairing or replacing, at Spirit Fitness' option, the product through one of our authorized service centers. All repairs must be preauthorized by Spirit Fitness. If the product is shipped to a service center freight charges to and from the service center will be the customer's responsibility. For replacement parts shipped while the product is under warranty, the customer will be responsible for shipping and handling charges. For in-home service, the customer will be responsible for a trip charge. There will be an additional trip charge if the customer is located over 100 miles from the nearest service center.
5. The owner is responsible for adequate packaging upon return to Spirit Fitness. Spirit Fitness is not responsible for damages in shipping. Make all freight damage claims with the appropriate freight carrier. **DO NOT SHIP ANY UNIT TO OUR FACTORY WITHOUT A RETURN AUTHORIZATION NUMBER.** All units arriving without a return authorization number will be refused.
6. For any further information, or to contact our service department by mail, send your correspondence to:

Spirit Fitness, Inc.
P.O. Box 2037
Jonesboro, AR 72402-2037

Product features or specifications as described or illustrated are subject to change without notice. All warranties are made by Spirit Fitness, Inc. This warranty applies only in the 48 contiguous United States. NOTE: This does not apply to Alaska or Hawaii.

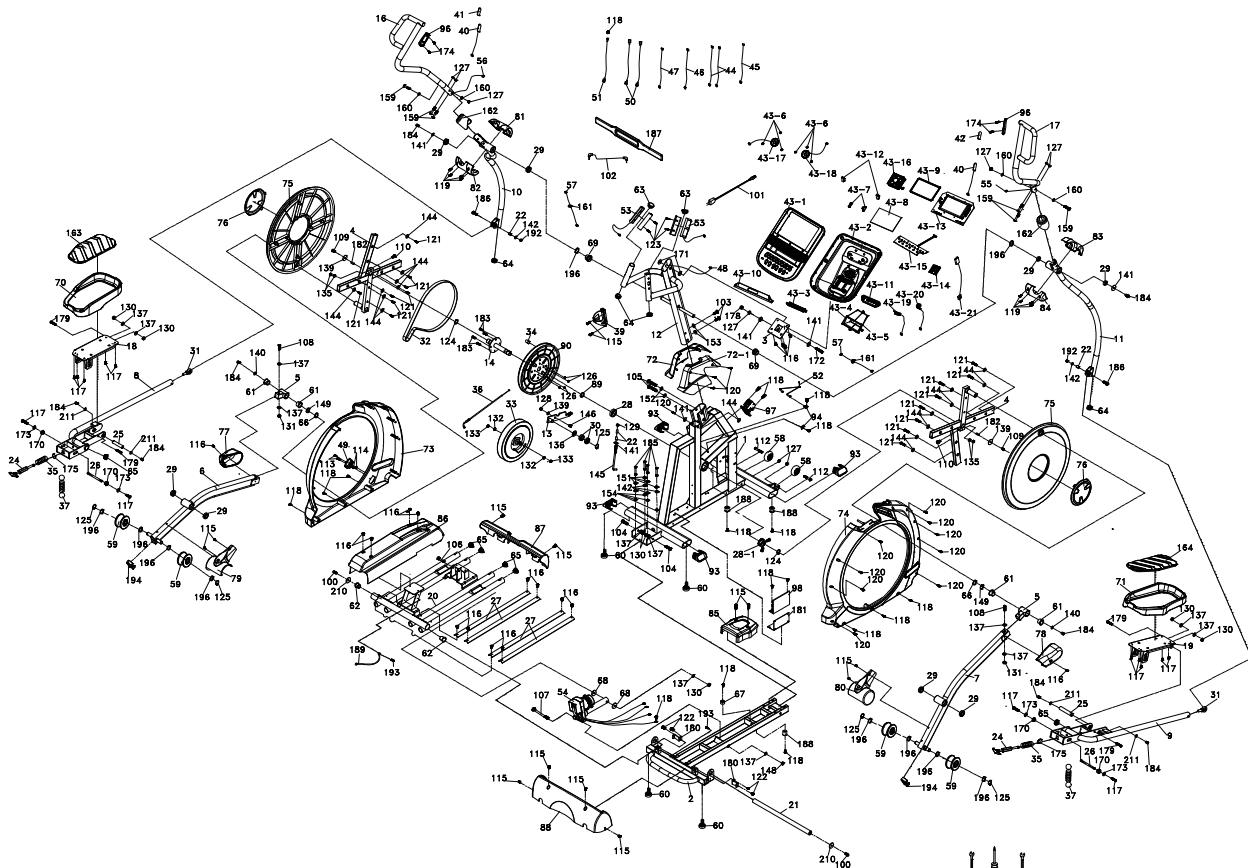

XE395ENT Parts List		
1	Main Frame	1
2	Rail Base Assembly	1
3	Console Holder Assembly	1
4	Cross Bar	2
5	Bushing Housing, Pedal Arm	2
6	Pedal Arm (L)	1
7	Pedal Arm (R)	1
8	Connecting Arm (L)	1
9	Connecting Arm (R)	1
10	Lower Handle Bar (L)	1
11	Lower Handle Bar (R)	1
12	Console Mast	1
13	Idler Bracket	1
14	Crank Axle	1
16	Swing Arm (L)	1
17	Swing Arm (R)	1
18	Adjustable Pedal (L)	1
19	Adjustable Pedal (R)	1
20	Rear Rail Assembly	1
21	Locking Tube Assembly	1
22	Rod End Sleeve	4
24	Locking Pin Assembly	2
25	Axle for Pedal	2
26	Axle Of Locking Pin	2
27	Aluminum Rail	4
28	6005_Bearing	1
28-1	6005-2RS_Bearing	1
29	6003_Bearing	8
30	6203_Bearing	2
31	M12 × P1.75_Rod End Bearing	2
32	Drive Belt	1
33	Flywheel	1

34	Magnet	1
35	Latch Spring	2
36	Steel Cable	1
37	Pedal Tension Spring	2
39	Drink Bottle Holder	1
40	Resistance Button W/Cable	2
41	Handgrip Resistance Label (INCLINE)	1
42	Handgrip Resistance Label (LEVEL)	1
43	Console Assembly	1
43~1	Console Top Cover	1
43~2	Console Bottom Cover	1
43~3	Deflector Fan Grill	1
43~4	Wind Duct (L)	1
43~5	Wind Duct (R)	1
43~6	Speaker Grill Anchor	6
43~7	Fan Grill Anchor	2
43~8	LCD Transparent Piece	1
43~9	Water-resist Rubber	1
43~10	Book Rack	1
43~11	Console Bottom Cover	1
43~12	Fan Fixing Plate	2
43~13	Console Display Board	1
43~14	Interface Board	1
43~15	Key Board	1
43~16	400m/m_Fan Assembly(White)	1
43~17	250m/m_Speaker W/Cable	1
43~18	460m/m_Speaker W/Cable	1
43~19	300m/m_W/Receiver, HR	1
43~20	350m/m_Earphone socket with cable and securing metal	1
43~21	USB Board	1
44	850m/m_Connecting Wire, Controller(Red)	2
45	650m/m_Computer Cable	1
46	500m/m_Connecting Wire, Incline Motor Power Cord	1
47	550m/m_Connecting Wire, Incline Motor	1

48	1600m/m_Computer Cable	1
49	AC Electronic Module	1
50	80m/m_Connecting Wire (White)	2
51	200m/m_Ground Wire	1
52	450m/m_Sensor W/Cable	1
53	850m/m_Handpulse W/Cable Assembly	2
54	Incline Motor	1
55	450m/m_Handle Wire (Upper), Resistance(White)	1
56	450m/m_Handle Wire (Upper), Incline(Red)	1
57	900m/m_Handle Wire (Lower), Resistance/Incline	2
58	Ø65_Transportation Wheel	2
59	Ø78_Slide Wheel , Urethane	4
60	Ø35 × 10m/m_Rubber Foot	4
61	WFM-2528-21_Bushing	4
62	Ø38 × Ø34 × Ø26 × 4 + 16T_Bushing	2
63	Ø32(1.8T)_Button Head Plug	2
64	Ø32 × 2.0T_Round Cap	4
65	32 × 2.5T_Round Cap	6
66	Ø25.5 × 33.5 × 1.5T_Nylon Wave Washer	2
67	Ø25 × Ø25 × 15T_Rubber Foot Pad	1
68	3/8" × 35 × 5T_Nylon Washer	2
69	Ø30 × 19m/m_Upright Bushing	2
70	Pedal (L)	1
71	Pedal (R)	1
72	Console Mast Cover(L)	1
72-1	Console Mast Cover(R)	1
73	Side Case(L)	1
74	Side Case (R)	1
75	Round Disk	2
76	Round Disk Cover	2
77	Pedal Arm Cover (L)	1
78	Pedal Arm Cover (R)	1
79	Slide Wheel Cover(L)	1

80	Slide Wheel Cover(R)	1
81	Front Handle Bar Cover (L)	1
82	Rear Handle Bar Cover (L)	1
83	Front Handle Bar Cover (R)	1
84	Rear Handle Bar Cover (R)	1
85	Bottom Cover	1
86	Incline Cover	1
87	Inclinable Rail Cover	1
88	Rear Bar Cover	1
89	Spacer Bushing	1
90	Ø330_Drive Pulley	1
93	Ø40 × Ø80_Oval End Cap	4
94	Sensor Rack	2
96	Handle Switch Bracket	2
97	Gear Motor	1
98	Incline Controller	1
100	5/16" × UNC18 × 1" _Hex Head Bolt	2
101	Power Cord	1
102	400m/m_Audio Cable	1
103	3/8" × 3/4" _Hex Head Bolt	2
104	3/8" × UNC16 × 1-1/2" _Hex Head Bolt	2
105	3/8" × 2-1/4" _Hex Head Bolt	2
106	3/8" × 2-1/2" _Hex Head Bolt	1
107	M10 × 130m/m_Hex Head Bolt	1
108	3/8" × 2-1/4" _Socket Head Cap Bolt	2
109	5/16" × UNC18 × 15L_Flat Head Socket Bolt	2
110	M8 × 1.25 × 40m/m_Socket Head Cap Bolt	2
112	5/16" × 1-3/4" _Button Head Socket Bolt	2
113	M4 × 12mm_Phillips Head Screw	2
114	M4 × P0.7 × 5T_Nyloc Nut	2
115	M5 × 15m/m_Phillips Head Screw	14
116	M5 × 10mm_Phillips Head Screw	18
117	M5 × 10mm_Phillips Head Screw(Nylock)	14

118	5 × 19m/m_Tapping Screw	18
119	3.5 × 12m/m_Sheet Metal Screw	8
120	3.5 × 16m/m_Sheet Metal Screw	13
121	5 × 16mm_Tapping Screw	16
122	M6 × 10m/m_Phillips Head Screw	4
123	3 × 20m/m_Tapping Screw	4
124	Ø25_C Ring	2
125	Ø17_C Ring	5
126	1/4" × 8T_Nyloc Nut	4
127	5/16" × 7T_Nyloc Nut	9
128	M8 × 7T_Nyloc Nut	1
129	M8 × 9T_Nyloc Nut	1
130	3/8" × 7T_Nyloc Nut	7
131	3/8" × 11T_Nyloc Nut	2
132	3/8" × UNF26 × 4T_Luck Nut	2
133	3/8" × UNF26 × 11T_Nut	2
135	M8 × 6.3T_Luck Nut	4
136	Ø17 × Ø23.5 × 1.0T_Flat Washer	1
137	Ø3/8" × Ø19 × 1.5T_Flat Washer	12
139	Ø5/16" × Ø35 × 1.5T_Flat Washer	3
140	Ø5/16" × 35 × 2.0T_Flat Washer	2
141	Ø5/16" × Ø23 × 1.5T_Flat Washer	6
142	Ø5/16" × Ø20 × 1.5T_Flat Washer	6
144	Ø1/4" × 19_Flat Washer	17
145	M8 × 170m/m_J Bolt	1
146	M8 × 20m/m_Carriage Bolt	1
148	M10 × 8T_Nyloc Nut	1
149	Ø25_Wave Washer	2
151	Ø8 × 1.5T_Spring Washer	4
152	Ø10 × 2T_Spring Washer	2
153	Ø3/8" × 23 × 2.0T_Curved Washer	2
154	Ø5/16" _Star Washer	4
155	13/14m/m_Wrench	1
157	Phillips Head Screw Driver	1

158	12/14m/m_Wrench	1
159	5/16" × 1-3/4" _Hex Head Bolt	6
160	Ø8 × 23 × 1.5T_Curved Washer	4
161	Switch Wire Cap	2
162	Swing Arm Bushing	2
163	Pedal Foam (L)	1
164	Pedal Foam (R)	1
170	Ø19 × Ø14 × Ø10 × (5+4)_Bushing	4
171	5/16" × 25 × 3T_Nylon Washer	2
172	5/16" × 2-1/2" _Hex Head Bolt	1
173	Ø5 × Ø15 × 1.5T_Flat Washer	4
174	M5 × 15m/m_Flat Head Socket Screw	4
175	Ø10_C Ring	2
178	13L_Bolt Cap	1
179	3/8" × 19m/m_Hex Head Bolt	4
180	Cover Holder(B)	2
181	Control Fixing Plate	1
182	Woodruff Key	2
183	1/4" × UNC20 × 3/4" _Hex Head Bolt	4
184	5/16" × UNC18 × 15L_Hex Head Bolt	8
185	5/16" × 2-1/4" _Hex Head Bolt	4
186	5/16" × 1-1/4" _Hex Head Bolt	2
187	Chest Strap (Optional)	1
188	Ø25 × 25mm_Rubber Foot Pad	3
189	250m/m_Ground Wire	1
192	5/16" × 9T_Nyloc Nut	2
193	Ø5 × 16L_Tapping Screw	2
194	Stabilizer End Cap	2
196	Ø17 × 0.5T_Wave Washer	10
210	Ø38 × Ø8.5 × 4T_Flat Washer	2
211	Ø5/16" × Ø23 × 3T_Flat Washer	4
210104		



800.258.4555
spiritservice@spiritfitness.com
www.spiritfitness.com



Spirit Fitness
3000 Nestle Road
Jonesboro, AR 72401

SPIRIT

XE395ENT Owners Manual
© 2021 All Rights Reserved
Revision: 02.25.2021