

PRO-FORM[®]

225 CSX

Model No. PFEX32925-INT.0

Serial No. _____

Write the serial number in the space above for reference.

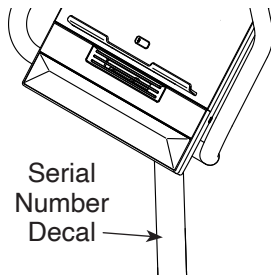

USER'S MANUAL

UNITED KINGDOM

Website: iconsupport.eu

E-mail: csuk@iconeurope.com

Write:

ICON Health & Fitness, Ltd.

Unit 4, Westgate Court

Silkwood Park

OSSETT

WF5 9TT

UNITED KINGDOM

AUSTRALIA

Call: 1800 993 770

E-mail: australiacc@iconfitness.com

Write:

iFIT Inc.

PO Box 635

WINSTON HILLS NSW 2153

AUSTRALIA

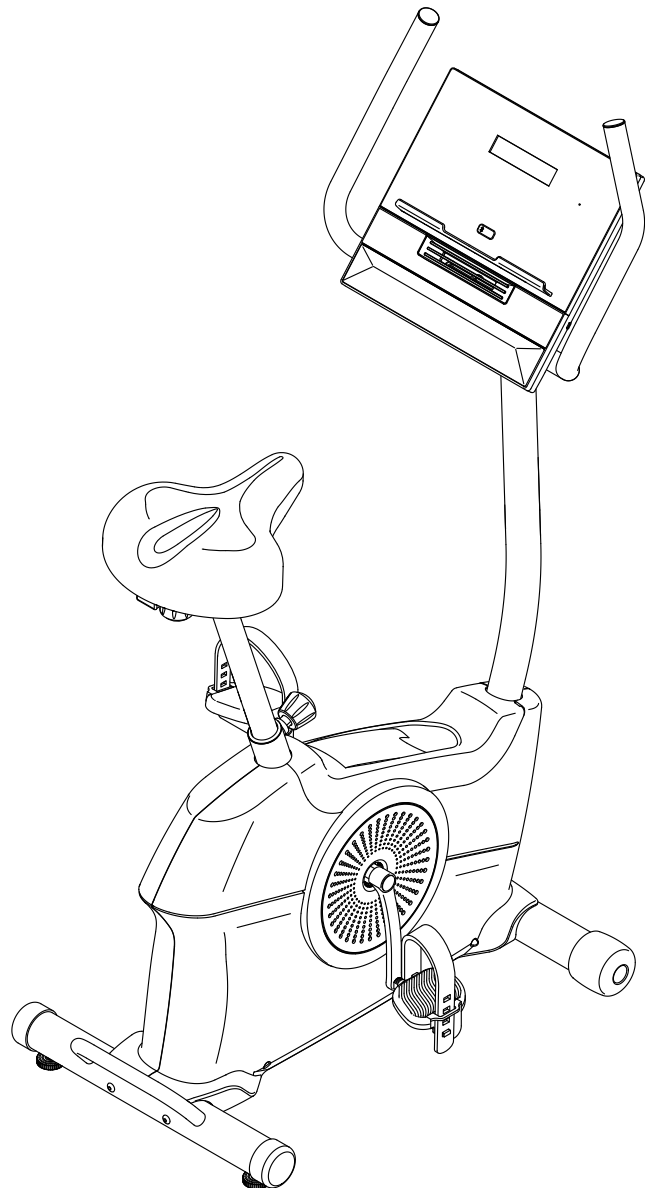

⚠ CAUTION

Read all precautions and instructions in this manual before using this equipment. Keep this manual for future reference.

TABLE OF CONTENTS

WARNING DECAL PLACEMENT	2
IMPORTANT PRECAUTIONS	3
BEFORE YOU BEGIN	4
PART IDENTIFICATION CHART	5
ASSEMBLY	6
HOW TO USE THE EXERCISE BIKE	14
HOW TO USE THE CONSOLE	15
MAINTENANCE AND TROUBLESHOOTING	23
EXERCISE GUIDELINES	25
PART LIST	26
EXPLODED DRAWING	27
ORDERING REPLACEMENT PARTS	Back Cover
RECYCLING INFORMATION	Back Cover
UK/EU DECLARATION OF CONFORMITY	Back Cover

WARNING DECAL PLACEMENT

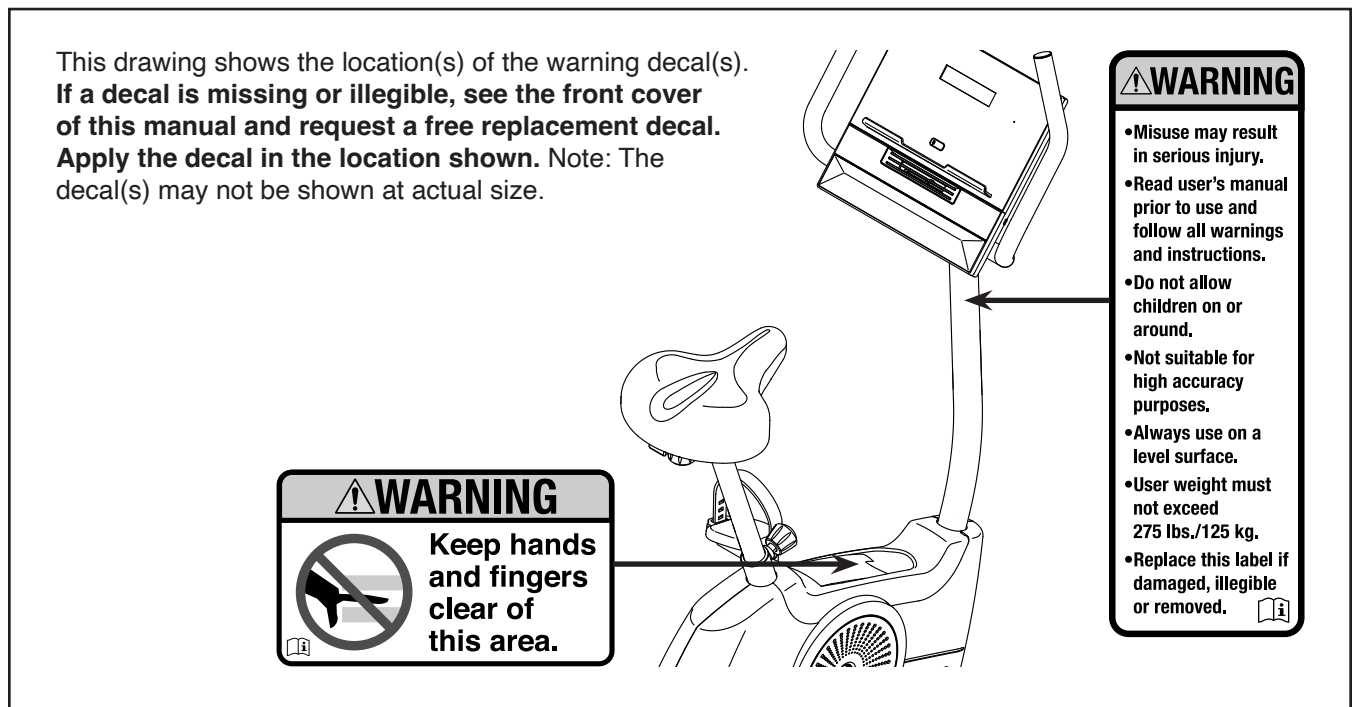

PROFORM and IFIT are registered trademarks of iFIT Inc. App Store is a trademark of Apple Inc., registered in the U.S. and other countries. Android and Google Play are trademarks of Google LLC. The Bluetooth® word mark and logos are registered trademarks of Bluetooth SIG, Inc. and are used under license. IOS is a trademark or registered trademark of Cisco in the U.S. and other countries and is used under license.

IMPORTANT PRECAUTIONS

⚠️ WARNING: To reduce the risk of serious injury, read all important precautions and instructions in this manual and all warnings on your exercise bike before using your exercise bike. IFIT assumes no responsibility for personal injury or property damage sustained by or through the use of this product.

1. It is the responsibility of the owner to ensure that all users of the exercise bike are adequately informed of all precautions.
2. Keep children under age 16 and pets away from the exercise bike at all times.
3. Consult your health care provider before beginning any exercise program. This is especially important for persons over age 35 or persons with pre-existing health problems.
4. Consult your health care provider before beginning or continuing any exercise program during pregnancy. Use the exercise bike only as authorized by your health care provider.
5. The exercise bike is not intended for use by persons with reduced physical, sensory, or mental capabilities or lack of experience and knowledge, unless they are given supervision or instruction about use of the exercise bike by someone responsible for their safety.
6. Use the exercise bike only as described in this manual.
7. The exercise bike is intended for home use only. Do not use the exercise bike in a commercial, rental, or institutional setting.
8. Keep the exercise bike indoors, away from moisture and dust. Do not put the exercise bike in a garage or covered patio, or near water.
9. Place the exercise bike on a level surface with at least 2 ft. (0.6 m) of clearance around the exercise bike. To protect the floor or carpet from damage, place a mat under the exercise bike.
10. Inspect and properly tighten all parts each time the exercise bike is used. Replace any worn parts immediately. Use only manufacturer-supplied parts.
11. Wear appropriate clothes while exercising; do not wear loose clothes that could become caught on the exercise bike. Always wear athletic shoes for foot protection.
12. The exercise bike should not be used by persons weighing more than 275 lbs. (125 kg).
13. Be careful when mounting and dismounting the exercise bike.
14. Always keep your back straight while using the exercise bike; do not arch your back.
15. Over exercising may result in serious injury or death. If you feel faint, if you become short of breath, or if you experience pain while exercising, stop immediately and cool down.

BEFORE YOU BEGIN

Thank you for selecting the revolutionary PROFORM® 225 CSX exercise bike. Cycling is an effective exercise for increasing cardiovascular fitness, building endurance, and toning the body. The 225 CSX exercise bike provides an impressive selection of features designed to make your workouts at home more effective and enjoyable.

reading this manual, please see the front cover of this manual. To help us assist you, note the product model number and serial number before contacting us (see the front cover of this manual).

Before reading further, please familiarize yourself with the parts that are labeled in the drawing below.

For your benefit, read this manual carefully before you use the exercise bike. If you have questions after

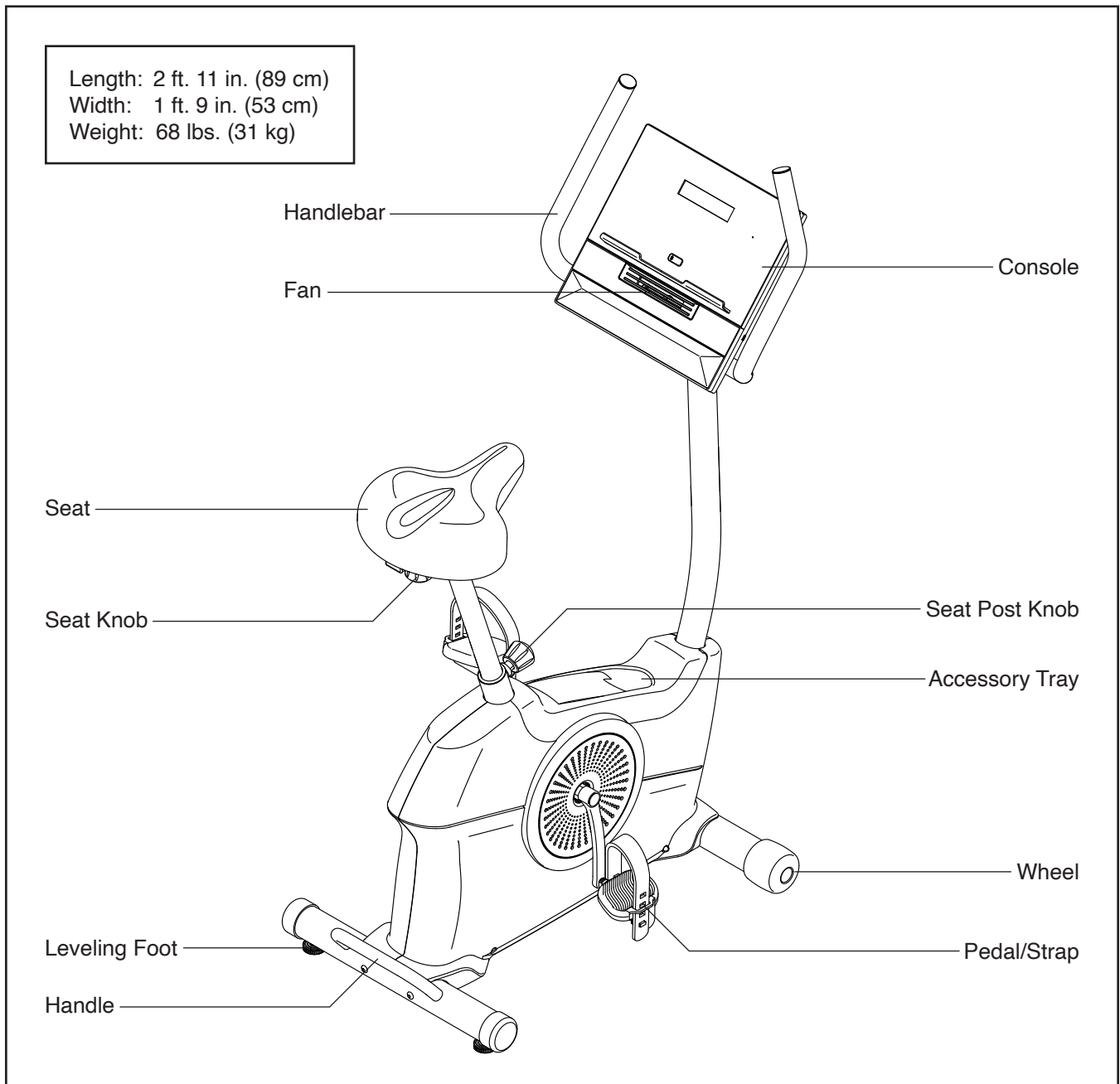

PART IDENTIFICATION CHART

Use the drawings below to identify the small parts used for assembly. The number in parentheses below each drawing is the key number of the part, from the PART LIST near the end of this manual. The number after the key number is the quantity used for assembly. **Note: If a part is not in the hardware kit, check to see whether it has been preassembled. Extra parts may be included.**

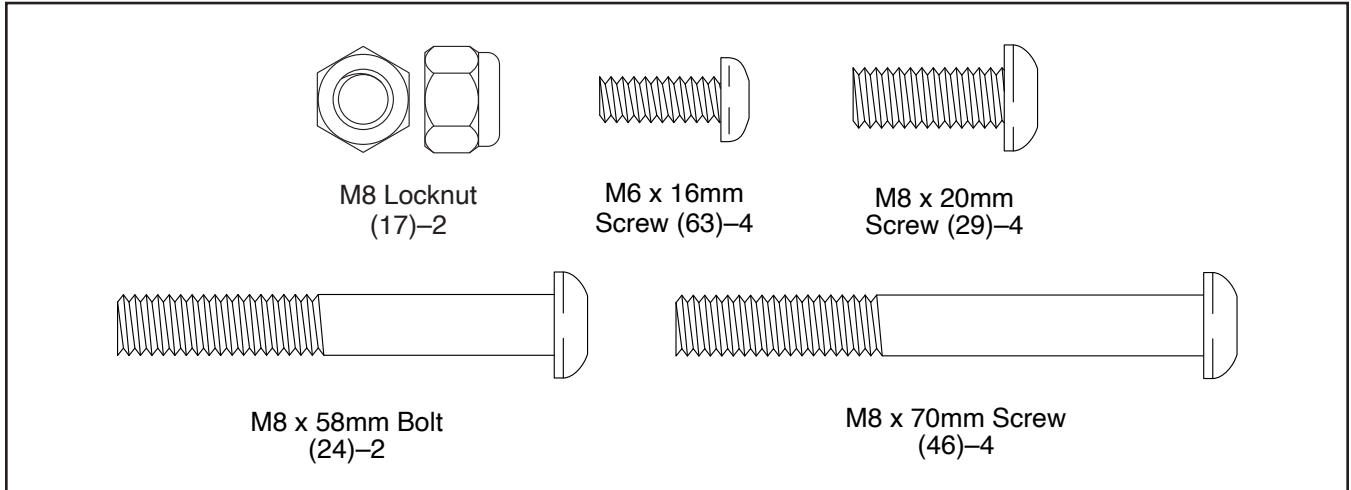

ASSEMBLY

- Assembly requires two persons.
- Place all parts in a cleared area and remove the packing materials. Do not dispose of the packing materials until you finish all assembly steps.
- Left parts are marked “L” or “Left” and right parts are marked “R” or “Right.”
- To identify small parts, see page 5.
- Assembly can be completed using the included tools. Note: **Keep the included tools.** One or more of the included tools may be needed to make adjustments in the future. To avoid damaging parts, do not use power tools for assembly or adjustment.

1. **To register your product and activate your warranty in the UK**, go to iconsupport.eu. If you do not have internet access, complete the warranty registration card in the warranty booklet and send it by registered post to the address on the back cover of the warranty booklet.

To register your product and activate your warranty in Australia, email or post the following information to the email address or postal address on the front cover of this manual.

- your receipt (make sure to keep a copy)
- your name, address, and telephone number
- the model number, serial number, and name of your product (see the front cover of this manual)

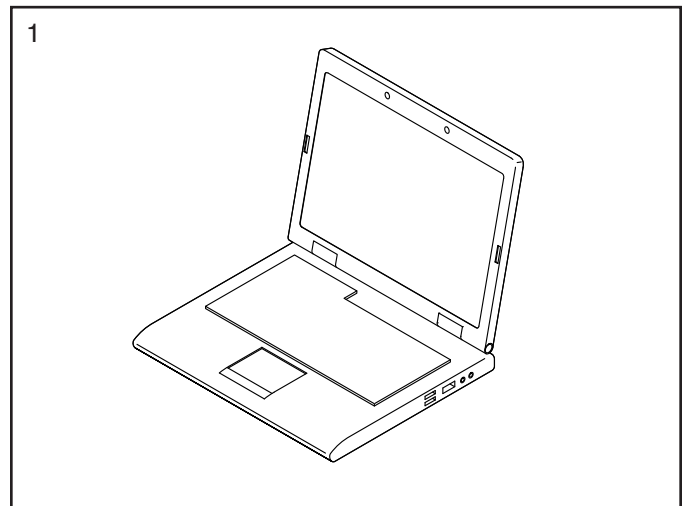

- Using a standard screwdriver, carefully pry the Shield Cover (26) off the Left and Right Shields (37, 58).

If there is a shipping tube (not shown) on the rear of the Frame (1), remove the screws from the shipping tube, and **discard the screws and the shipping tube.**

Next, set a sturdy piece of packing material under the rear of the Frame (1). **Have a second person hold the Frame to prevent it from tipping.**

Identify the Rear Stabilizer (44). Attach the Rear Stabilizer to the Frame (1) with two M8 x 70mm Screws (46).

Then, remove the packing material from under the rear of the Frame (1).

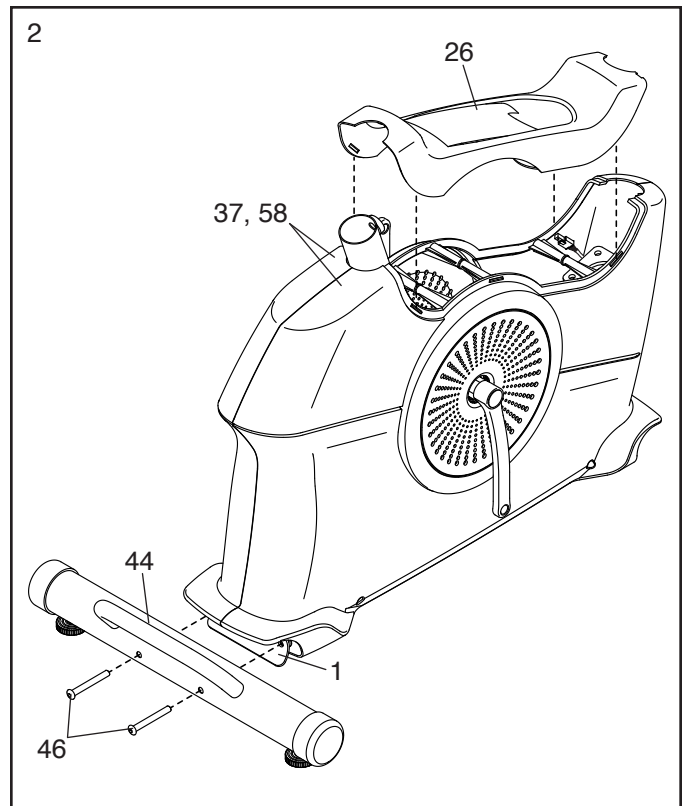

- If there is a shipping tube (not shown) on the front of the Frame (1), remove the screws from the shipping tube and **discard the screws and the shipping tube.**

Next, set a sturdy piece of packing material under the front of the Frame (1).

Attach the Front Stabilizer (8) to the Frame (1) with two M8 x 70mm Screws (46).

Then, remove the packing material from under the front of the Frame (1).

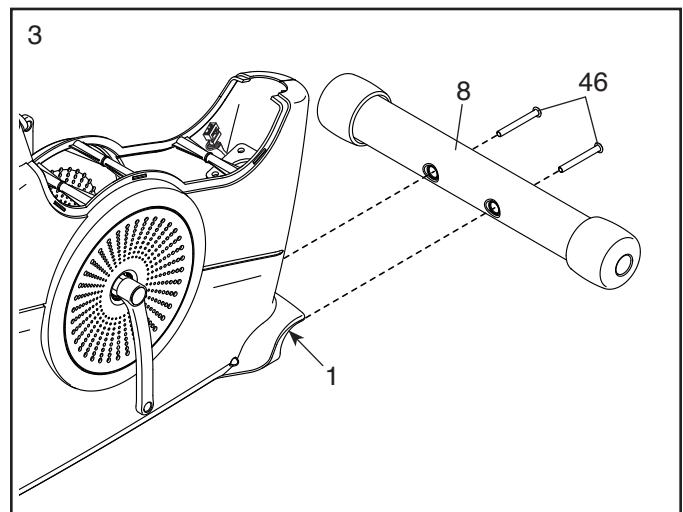

4. Set the Seat Carriage (15) on the Seat Post (18) and hold it in place.

Then, insert the Seat Knob (19) upward into the Seat Post (18), and tighten the Seat Knob into the Seat Bracket (14) inside of the Seat Carriage (15).

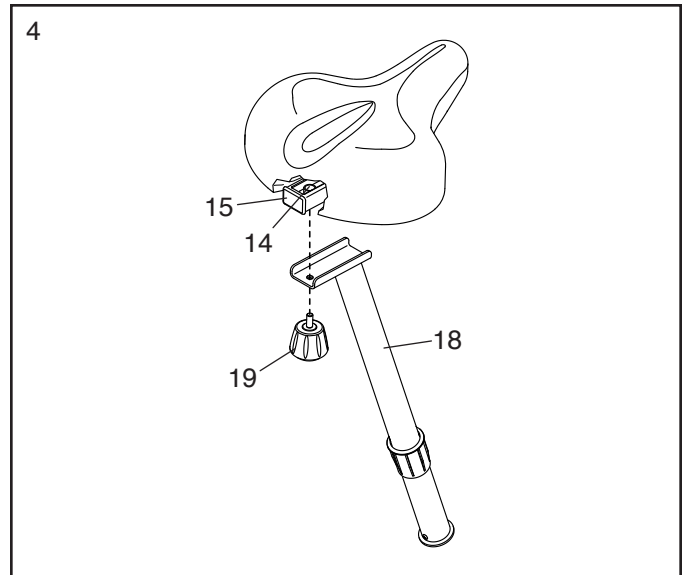

5. Hold the Seat Post (18) near the Frame (1), and position the Seat Post Bushing (21) so that the lock tab (A) is covering the oval hole (B) in the Seat Post.

Have a second person loosen the Seat Post Knob (28) a few turns and pull it outward.

Insert the Seat Post (18) and the Seat Post Bushing (21) into the Frame (1) until the lock tab (A) snaps into the indicated hole (C) in the Frame.

Next, slide the Seat Post (18) upward or downward to the desired position, and release the Seat Post Knob (28) into an adjustment hole (D) in the Seat Post. Then, tighten the Seat Post Knob.

Move the Seat Post (18) upward or downward slightly to make sure that the Seat Post Knob (28) is engaged in an adjustment hole (D).

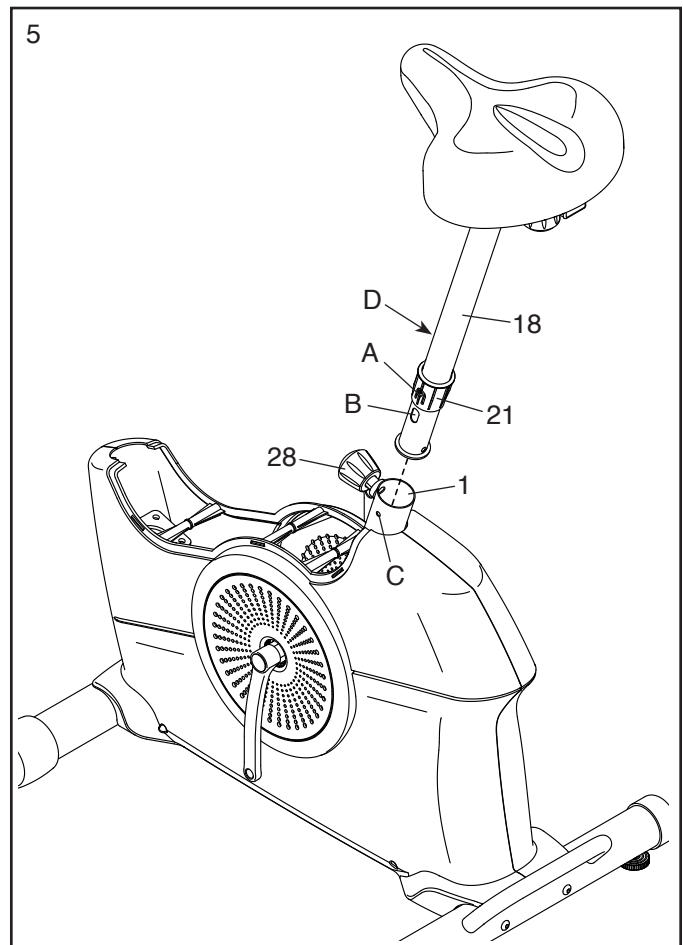

6. **Do not pinch the Main Wire (25).** Orient the Upright (27) as shown, and hold it on the Frame (1).

Attach the Upright (27) with four M8 x 20mm Screws (29); **start all four Screws, and then tighten them.**

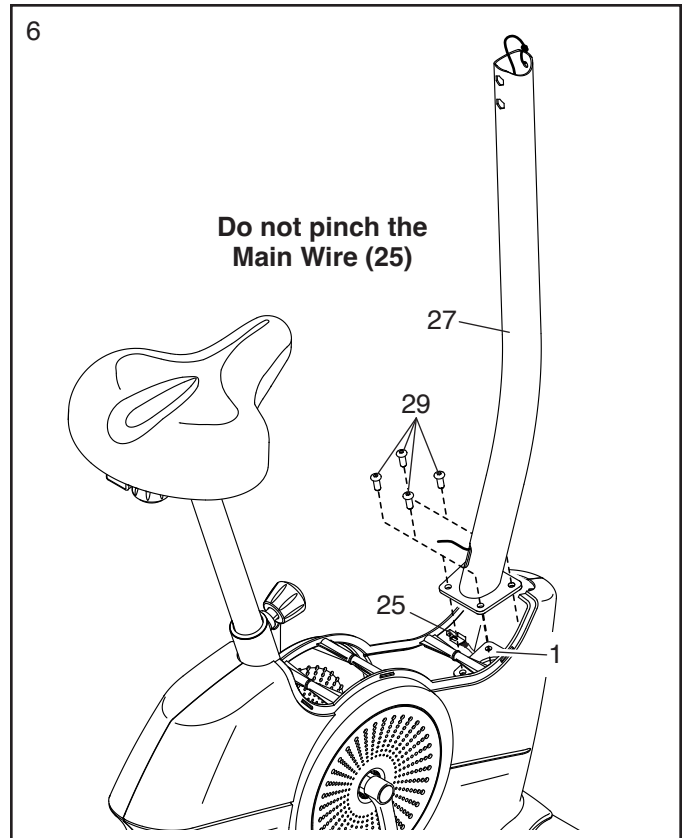

7. **See the inset drawing.** Locate the wire tie (E) in the Upright (27). Tie the wire tie (E) through the wire pull (F) on the Main Wire (25).

Then, pull the upper end of the wire tie (E) until the Main Wire (25) is routed through the Upright (27).

Do not untie the wire tie (E) yet.

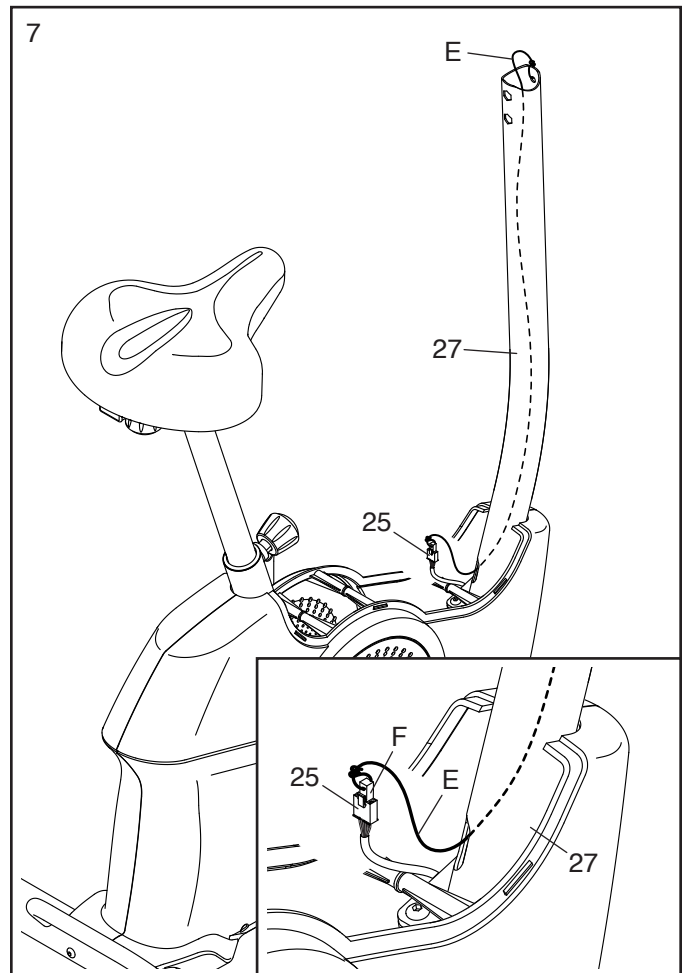

8. Orient the Shield Cover (26) as shown, and press it onto the Left and Right Shields (37, 58).

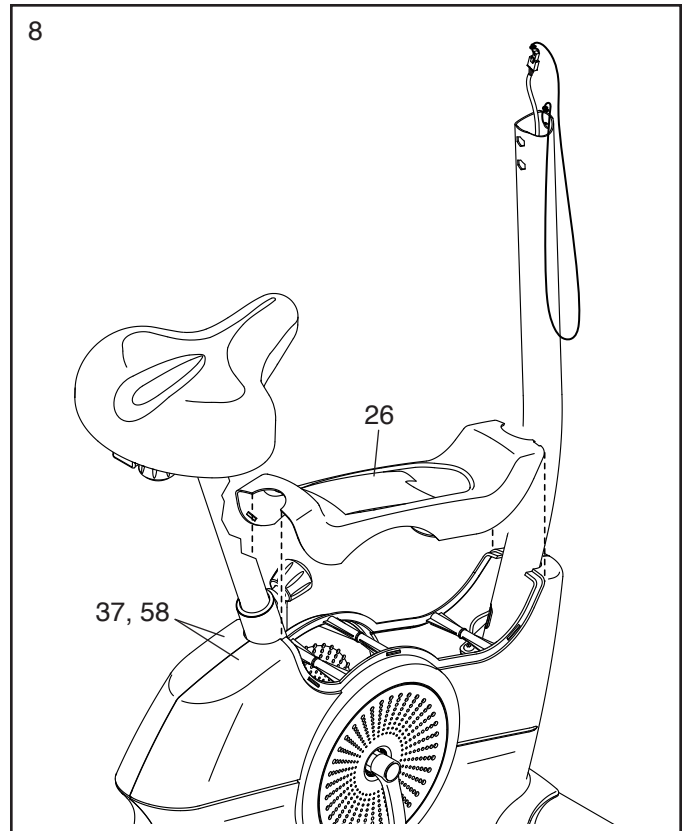

9. **See the inset drawing.** Grip the connector on the Main Wire (25). Then, press the small latch (G) on the wire pull (F), and remove the wire pull. **Discard the wire pull and the wire tie (E).**

Next, hold the Handlebar (4) near the Upright (27), and route the Main Wire (25) upward through the Handlebar and out of the indicated opening (H).

Do not pinch the Main Wire (25). Carefully insert the Handlebar (4) into the Upright (27). Attach the Handlebar (4) with two M8 x 58mm Bolts (24) and two M8 Locknuts (17). **Make sure that the Locknuts are in the hexagonal holes (I).**

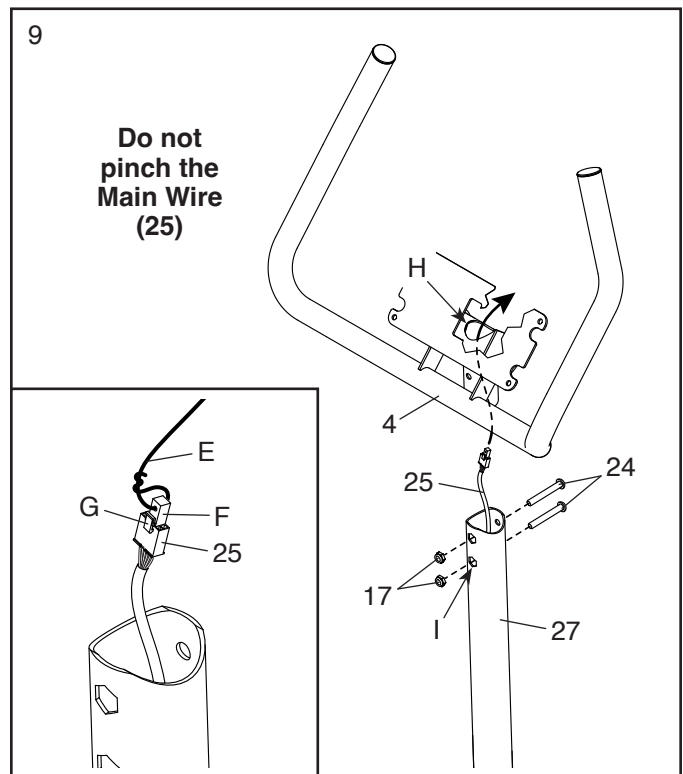

10. **See the upper drawing.** Hold the Console (7) near the Handlebar (4), and insert the console wire (J) through the indicated slot (K).

See the lower drawing. Do not pinch the wires. Attach the Console (7) to the Handlebar (4) with four M6 x 16mm Screws (63); **start all four Screws, and then tighten them.**

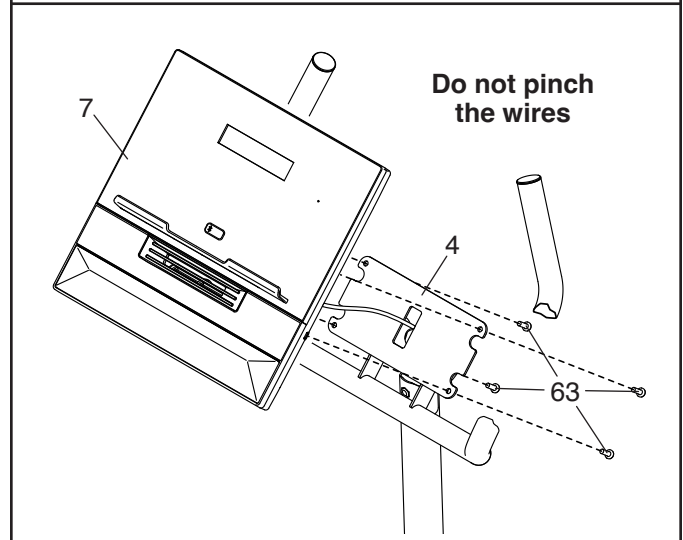
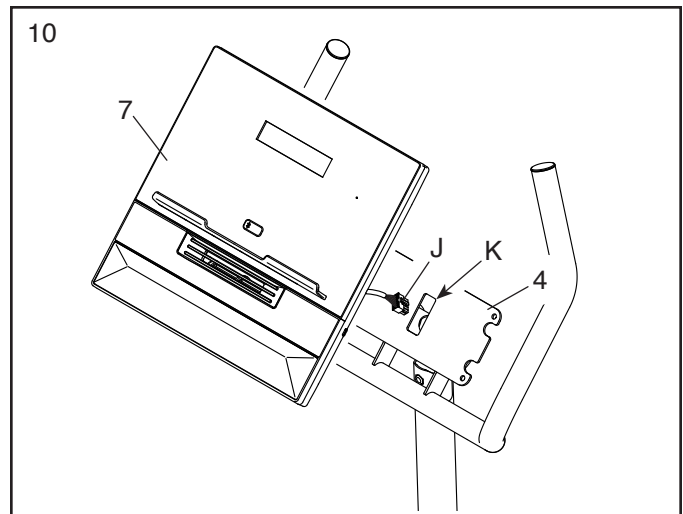

11. Connect the console wire (J) to the Main Wire (25).

IMPORTANT: The wire connectors should slide together easily and snap into place with an audible click. You must connect the wires properly for your exercise bike to function properly.

Then, insert the connectors and the excess wire downward into the indicated opening (H).

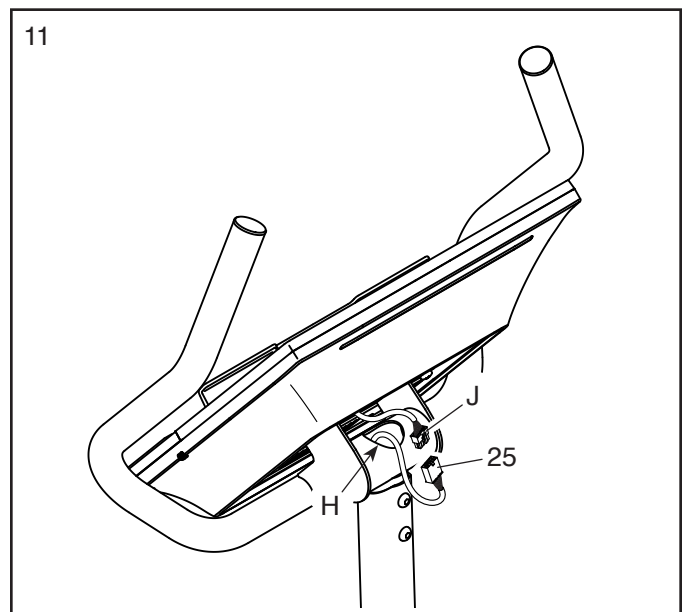

12. **Do not pinch the wires.** Slide the Console Cover (3) onto the Handlebar (4), and then press the Console Cover onto the back of the Console (7).

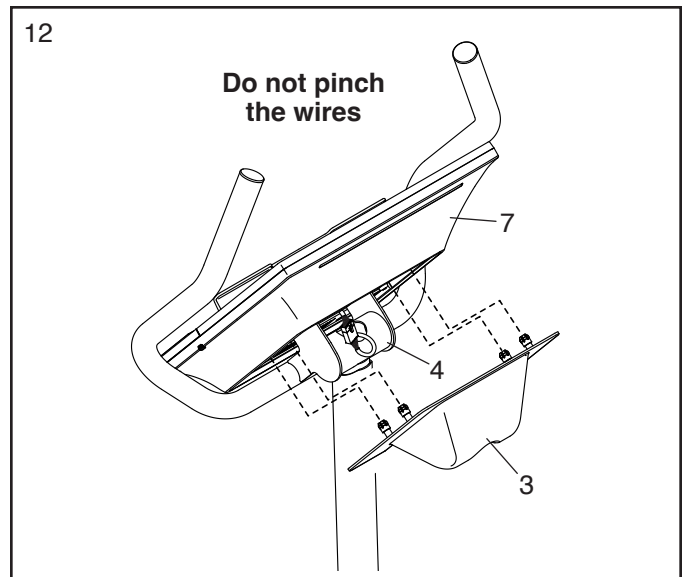

13. Identify the Right Pedal (60). Using your fingers, turn the Right Pedal about halfway into the Right Crank Arm (59). Then, use the included wrench to **firmly tighten** the Right Pedal.

Repeat this step with the Left Pedal (32).
IMPORTANT: You must turn the Left Pedal COUNTERCLOCKWISE to attach it.

Adjust the strap on the Right Pedal (60) to the desired position, and press the ends of the strap (L) onto the tabs (M) on the Right Pedal. **Adjust the strap on the Left Pedal (32) in the same way.**

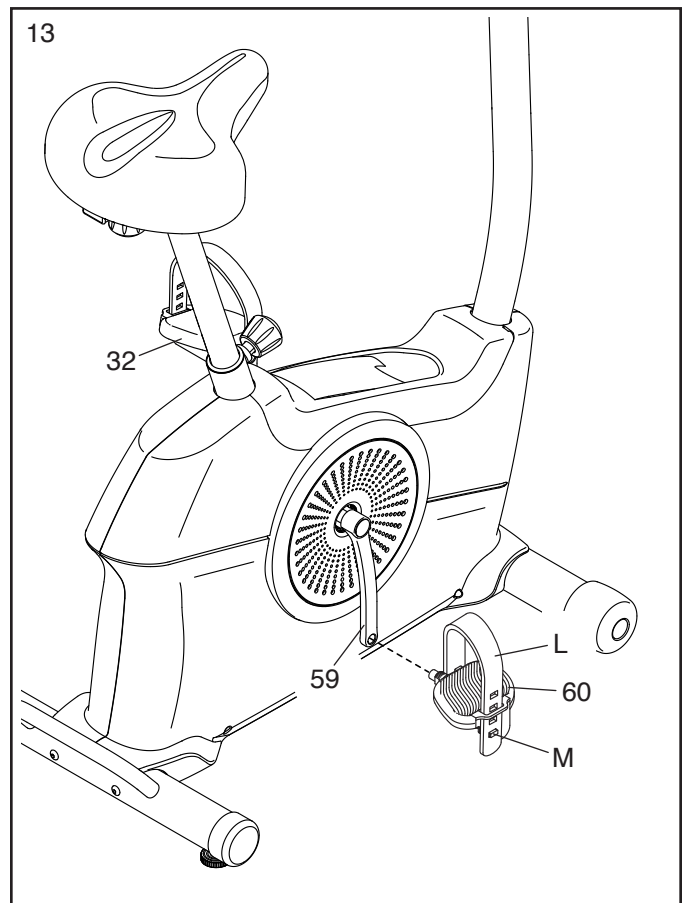

14. Plug the Power Adapter (30) into the receptacle on the front of the exercise bike.

Note: To plug the Power Adapter (30) into an outlet, see page 14.

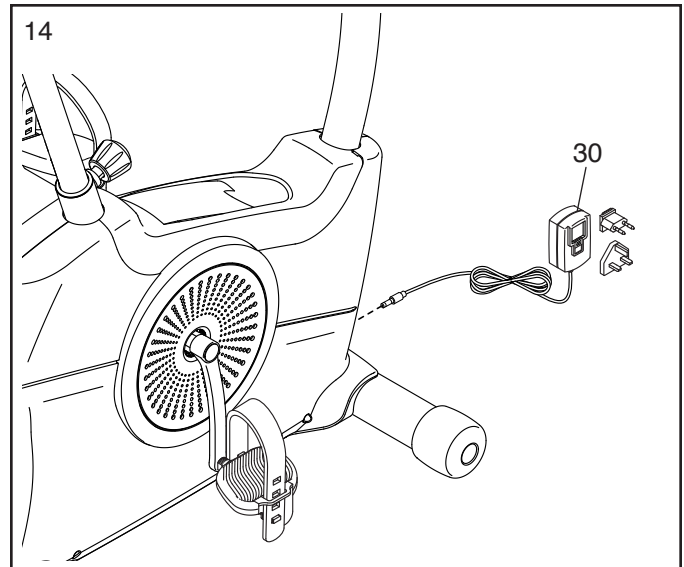

15. **Make sure that all parts are properly tightened before you use the exercise bike.** Extra parts may be included. Place a mat under the exercise bike to protect the floor or carpet. To avoid damage to the console, keep the exercise bike out of direct sunlight. Keep the included tools; one or more of the tools may be needed to make adjustments in the future.

HOW TO USE THE EXERCISE BIKE

HOW TO PLUG IN THE POWER ADAPTER

IMPORTANT: If the exercise bike has been exposed to cold temperatures, allow it to warm to room temperature before you plug in the power adapter (A). If you do not do this, you may damage the console displays or other electronic components.

Plug the power adapter (A) into the receptacle on the front of the exercise bike. Then, plug the power adapter into an appropriate outlet that is properly installed in accordance with all local codes and ordinances.

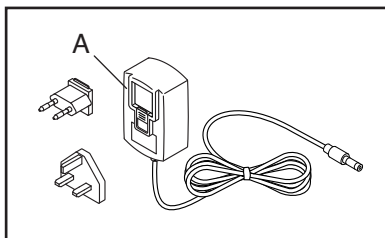

HOW TO LEVEL THE EXERCISE BIKE

If the exercise bike rocks slightly on your floor during use, turn one or both of the leveling feet (B) beneath the rear stabilizer until the rocking motion is eliminated.

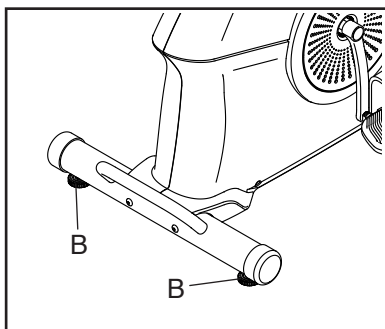

HOW TO ADJUST THE PEDAL STRAPS

To adjust the pedal straps, first pull the ends of the straps (E) off the tabs (F) on the pedals. Then, adjust the straps to the desired position, and press the ends of the straps onto the tabs.

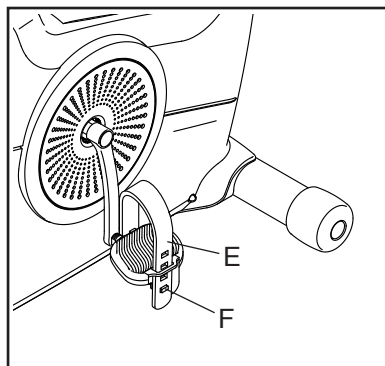

HOW TO ADJUST THE HEIGHT OF THE SEAT

For effective exercise, the seat should be at the proper height. As you pedal, there should be a slight bend in your knees when the pedals are in the lowest position.

To adjust the seat, first loosen the seat post knob (C) a few turns and pull it outward. Next, slide the seat post upward or downward to the desired position, and release the seat post knob into an adjustment hole in the seat post. Then, tighten the seat post knob. **Move the seat post upward or downward slightly to make sure that the seat post knob is engaged in one of the adjustment holes.**

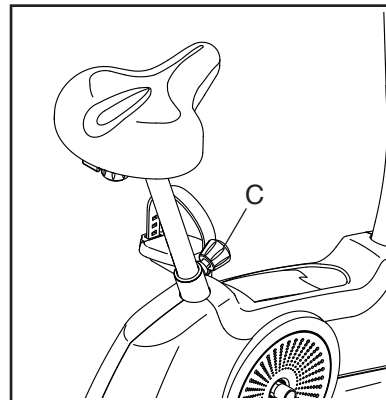

HOW TO ADJUST THE HORIZONTAL POSITION OF THE SEAT

To adjust the horizontal position of the seat, loosen the seat knob (D) a few turns, move the seat forward or backward to the desired position, and then firmly tighten the seat knob.

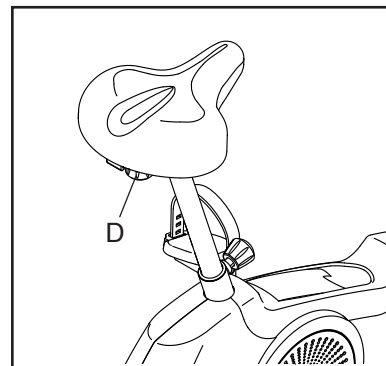

HOW TO USE THE CONSOLE

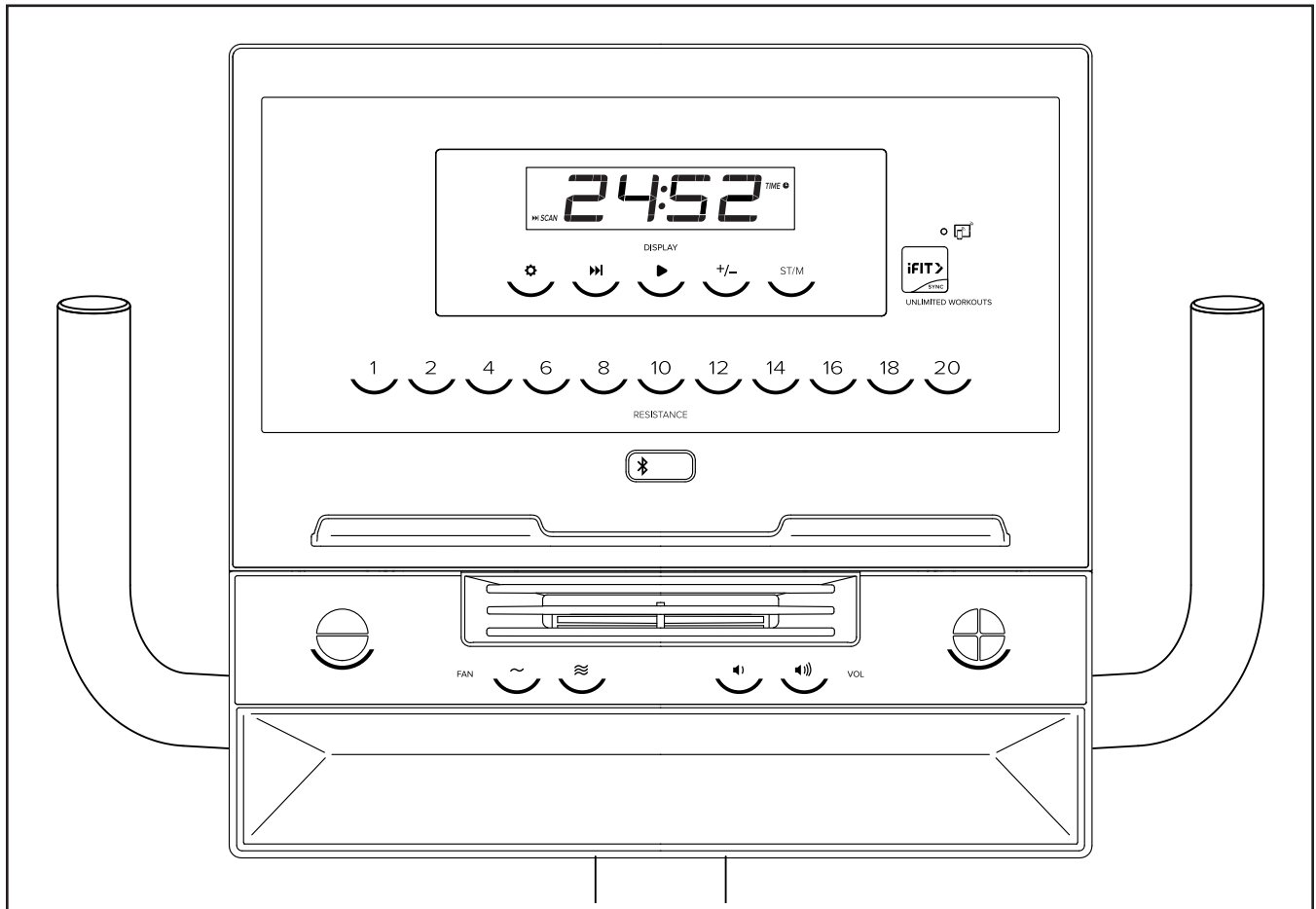

FEATURES OF THE CONSOLE

The console offers a selection of features designed to make your workouts more effective and enjoyable.

When you use the manual mode of the console, you can change the resistance of the pedals with a touch of a button. As you exercise, the console will display continuous exercise feedback.

The console also features wireless technology that enables the console to connect to iFIT®. With the iFIT app, you can choose from a rotating selection of featured workouts that automatically control the resistance of the pedals as iFIT trainers guide you through immersive exercise sessions.

With an iFIT subscription, you can access a large and varied library of thousands of destination and studio workouts, create your own workouts, track your workout results, and access many other features.

You can also use the charging port on the console to charge your USB-C compatible device while you exercise (see page 21).

To use the manual mode, see page 16. **To use an iFIT workout**, see page 18. **To change console settings**, see page 19.

Note: If there is a sheet of plastic on the display, remove the plastic.

HOW TO USE THE MANUAL MODE

1. Turn on the console.

To turn on the console, press any button on the console or simply begin pedaling.

2. Get ready for the workout.

To use the fan, see page 21.

To use the sound system, see page 21.

To use an optional heart rate monitor, see page 22.

3. Change the resistance of the pedals as desired.

To change the resistance of the pedals as you exercise, press one of the numbered Resistance buttons or press the Resistance increase and decrease buttons.

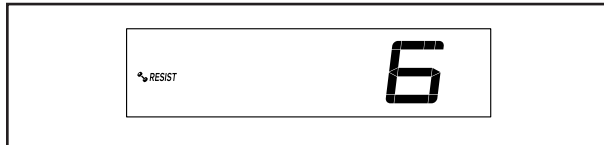

Note: After you press a button, it will take a moment for the pedals to reach the selected resistance level.

4. Follow your progress with the display.

The display can show the following workout information:

Calories (CALs)—The approximate number of calories you have burned.

Calories per Hour (CALs/HR)—The approximate number of calories you are burning per hour.

Distance (MI or KM)—The distance that you have pedaled in miles or kilometers. To change the unit of measurement, press the St/M button.

Pace—Your pedaling speed in minutes per mile or minutes per kilometer. To change the unit of measurement, press the St/M button.

Pulse (BPM and heart symbol)—Your heart rate when you use a compatible heart rate monitor (see page 22).

Resistance (RESIST)—The resistance level of the pedals.

RPM—Your pedaling speed in revolutions per minute (RPM).

Speed (MPH or KPH)—Your pedaling speed in miles per hour or kilometers per hour. To change the unit of measurement, press the St/M button.

Time—The elapsed time.

Press the Display button (B) repeatedly to view the desired workout information in the display.

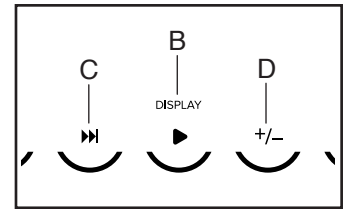

Scan mode—The console also has a scan mode that will display workout information in a repeating cycle. To turn on the scan mode, press the Scan button (C); the scan indicator (E) and the word SCAN will turn on in the display.



To manually advance the scan cycle, press the Scan button (C) repeatedly.

To turn off the scan mode, press the Display button (B); the scan indicator and the word SCAN will turn off.

You can also customize the scan mode to display only the desired workout information in the repeating cycle.

To customize the scan mode, first press the Display button (B) repeatedly until the workout information that you want to add to or remove from the scan cycle appears in the display.

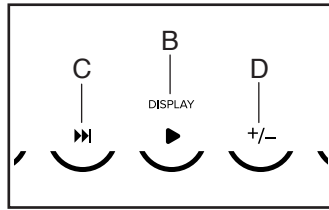

Next, press the Add/Remove button (D) to add or remove that workout information from the scan cycle. **When workout information is added**, its indicator will turn on in the display. **When workout information is removed**, its indicator will turn off.

Then, press the Scan button (C) to turn on the scan mode.

Note: The console will show your heart rate in the scan cycle automatically whenever it detects a pulse from a compatible heart rate monitor.

To change the volume level of the console, press the volume increase and decrease buttons.

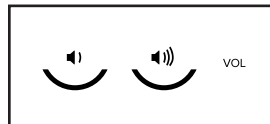

5. Pause or end the workout.

To pause the workout, simply stop pedaling. When the workout is paused, the time will flash in the display. To continue the workout, simply resume pedaling.

To end the workout, simply stop pedaling and wait for a few minutes for the console display to reset.

6. When you are finished exercising, the console will turn off automatically.

If the pedals are not moved and the console buttons are not pressed for a few seconds, the console will pause.

If the pedals are not moved and the console buttons are not pressed for a few minutes, the console will turn off automatically.

Note: The console features a demo mode designed to be used if the exercise bike is displayed in a store. If the demo mode is turned on, the console will not turn off and the display will not be reset when you finish exercising. To turn off the demo mode, see HOW TO CHANGE CONSOLE SETTINGS on pages 19 and 20.

HOW TO USE AN iFIT WORKOUT

The console offers access to a large and varied library of iFIT workouts when you download the iFIT app to your smart device and connect it to the console.

Note: The console supports Bluetooth® connections to smart devices via the iFIT app and to compatible heart rate monitors. Other Bluetooth connections are not supported.

1. Download and install the iFIT app on your smart device.

On your iOS® or Android™ smart device, open the App StoreSM or the Google Play™ store, search for the free iFIT app, and then install the app on your smart device. **Make sure that the Bluetooth option is enabled on your smart device.**

Then, open the iFIT app and follow the instructions to set up an iFIT account and customize settings.

Take time to explore the iFIT app and learn about its features and settings.

2. Get ready for the workout.

To use the fan, see page 21.

To use the sound system, see page 21.

To use an optional heart rate monitor, see page 22. Note: If you are connecting both your heart rate monitor and your smart device to the console, **you must connect your heart rate monitor before you connect your smart device.**

3. Connect your smart device to the console.

Press the iFIT Sync button on the console; the console pairing number will appear in the display. Then, follow the instructions in the iFIT app to connect your smart device to the console.

When a connection is established, the LED on the console will turn solid blue or the Bluetooth symbol will appear in the display.

4. Select an iFIT workout.

In the iFIT app, touch the buttons at the bottom of the screen to select either the home screen (Home button) or the workout library (Browse button).

To select a workout from the home screen or the workout library, simply touch the desired workout button on the screen. Slide or flick the screen to scroll as necessary.

When you select a workout, the screen will show an overview of the workout that includes details such as the duration and distance of the workout and the approximate number of calories you will burn during the workout.

5. Start the workout.

Touch *Start Workout* to start the workout.

During some workouts, an iFIT trainer will guide you through an immersive video workout. Touch the screen in any open space to view and select music, trainer voice, and volume options for the workout.

During some workouts, the screen will show a map of the route and a marker indicating your progress. Touch the buttons on the screen to select the desired map options.

If the resistance setting for the current segment of the workout is too high or too low, you can manually override the setting by pressing the Resistance buttons on the console.

To return to the programmed resistance settings of the workout, touch *Follow Trainer*.

Note: The calorie goal shown in the workout description is an estimate of the number of calories that you will burn during the workout. The actual number of calories that you burn will depend on various factors, such as your weight. In addition, if you manually change the resistance level during the workout, the number of calories you burn will be affected.

6. Pause or end the workout.

To pause the workout, simply touch the screen or stop pedaling. To continue the workout, simply resume pedaling.

To end the workout, touch the screen to pause the workout, and then follow the prompts on the screen to end the workout and return to the home screen.

When the workout ends, a workout summary will appear on the screen. If desired, you can select options such as adding the workout to your schedule or adding the workout to your favorites list. Then, touch *Finish* to return to the home screen.

7. Disconnect your smart device from the console.

To disconnect your smart device from the console, first select the disconnect option in the iFIT app. Then, press and hold the iFIT Sync button on the console until the LED on the console turns solid green or the Bluetooth symbol disappears from the display.

Note: All Bluetooth connections between the console and other devices (including any smart devices, heart rate monitors, and so forth) will be disconnected.

6. When you are finished exercising, the console will turn off automatically.

See step 6 on page 17.

HOW TO CHANGE CONSOLE SETTINGS

1. Select the settings mode.

To select the settings mode, press the settings button (E). The first settings screen will appear in the display.

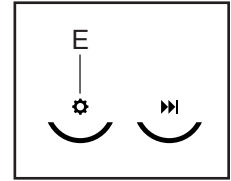

2. Navigate the settings mode.

While the settings mode is selected, you can navigate through several settings screens. Press the Display button repeatedly to select the desired settings screen.

3. Change settings as desired.

Software Version Number—The software version number will appear in the display.

Unit of Measurement—The currently selected unit of measurement will appear in the display. The console can show speed and distance in standard or metric units of measurement. To change the unit of measurement, press the St/M button repeatedly. To view workout information in standard units, select STD. To view workout information in metric units, select MET.

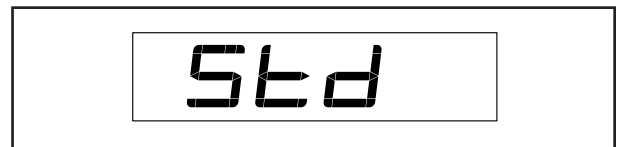

Display Test—This screen is intended to be used by service technicians to identify whether the display is working correctly.

Button Test—This screen is intended to be used by service technicians to identify whether a certain button is working correctly.

Total Time—The word TIME will appear in the display. The display will show the total number of hours that the exercise bike has been used.

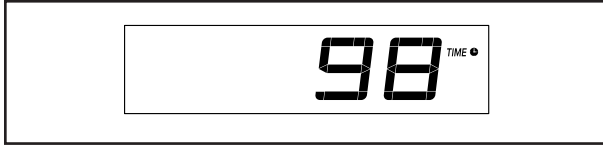

Total Distance—The letters MI or KM will appear in the display. The display will show the total distance (in miles or kilometers) that the exercise bike has been pedaled.

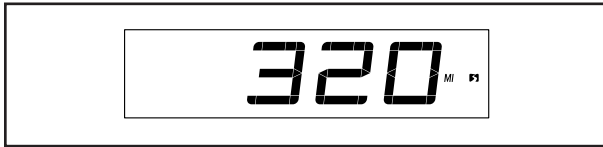

Contrast Level—The currently selected contrast level will appear in the display. Press the Resistance increase and decrease buttons to adjust the contrast level.

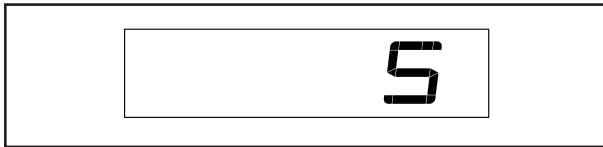

Demo Mode—The currently selected demo mode option will appear in the display. The console features a demo mode, designed to be used if the exercise bike is displayed in a store. If the demo mode is turned on, the console will not become inactive and the display will not be reset when you finish exercising. Press the Resistance increase button repeatedly to select a demo mode option. To turn on the demo mode, select DON. To turn off the demo mode, select DOFF.



4. Exit the settings mode.

Press the settings button (E) to exit the settings mode.

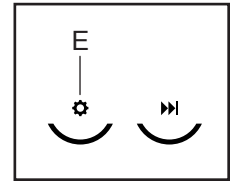

HOW TO USE THE CHARGING PORT

The console features a charging port to charge USB-C compatible devices, such as smartphones and tablets, while you exercise.

To use the charging port, plug a USB-C charging cable (not included) into the charging port on the right side of the console and into the receptacle on your device; **make sure that the USB-C charging cable is fully plugged in.** Note: The charging port cannot be used to view or transfer data or to play music through the console sound system.

HOW TO USE THE FAN

The fan has multiple speed settings. Press the Fan increase and decrease buttons on the console repeatedly to select a fan speed or to turn off the fan.



Note: If the pedals are not moved for a while when the home screen is selected, the fan will turn off automatically.

HOW TO USE THE SOUND SYSTEM

1. **Make sure that your device's Bluetooth setting is turned on, and hold your device near the console.**
2. **Press and hold the Bluetooth Audio button on the console for 3 seconds.**

A tone will sound and the Bluetooth button will begin flashing to indicate that the console has entered pairing mode.

3. **Pair your device to the console.**

Once your device and the console pair successfully, the audio from your device will play through the console speakers. To adjust the volume, press the Vol increase and decrease buttons on the console or the use the volume control on your personal audio player.

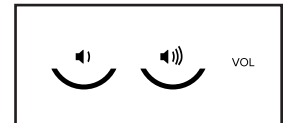

Note: The console can save multiple devices in its memory. If you have previously paired your device to the console, you can simply press the Bluetooth Audio button to connect your device to the console.

4. **Erase the console's device memory if necessary.**

If you need to erase all of the Bluetooth-enabled devices saved in the console's memory, press and hold the Bluetooth Audio button for 10 seconds

HOW TO USE AN OPTIONAL HEART RATE MONITOR

Whether your goal is to burn fat or to strengthen your cardiovascular system, the key to achieving the best results is to maintain the proper heart rate during your workouts.

The optional heart rate monitor will enable you to continuously monitor your heart rate while you exercise, helping you to reach your personal fitness goals. The console is compatible with all Bluetooth® Smart heart rate monitors.

To purchase an optional heart rate monitor, please see the front cover of this manual.

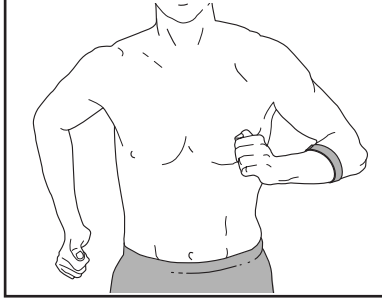

To connect your Bluetooth Smart heart rate monitor to the console, press the iFIT Sync button on the console; the console pairing number will appear in the display. When your heart rate monitor is connected, the LED on the console will flash red twice. Note: If there is more than one compatible heart rate monitor near the console, the console will connect to the heart rate monitor with the strongest signal.

To disconnect your heart rate monitor from the console, press and hold the iFIT Sync button on the console until the LED on the console turns solid green. Note: All Bluetooth connections between the console and other devices (including any smart devices, heart rate monitors, and so forth) will be disconnected.

MAINTENANCE AND TROUBLESHOOTING

MAINTENANCE

Regular maintenance is important for optimal performance and to reduce wear. Inspect and properly tighten all parts each time the exercise bike is used.

Replace any worn parts immediately. Use only manufacturer-supplied parts.

To clean the exercise bike, use a damp cloth and a small amount of mild soap. **IMPORTANT: To avoid damage to the console, keep liquids away from the console and keep the console out of direct sunlight.**

PEDAL MAINTENANCE

Tighten the pedals weekly. Tighten the **right** pedal **clockwise**, and tighten the **left** pedal **counterclockwise**.

TROUBLESHOOTING

Many problems can be solved with the simple steps in this section. If further assistance is needed, please see the front cover of this manual.

CONSOLE TROUBLESHOOTING

If the console does not turn on, make sure that the power adapter is fully plugged in.

If a replacement power adapter is needed, please see the front cover of this manual to order one. IMPORTANT: To avoid damaging the console, use only a manufacturer-supplied regulated power adapter.

HOW TO ADJUST THE REED SWITCH

If the console does not display correct feedback, the reed switch should be adjusted.

To adjust the reed switch, **first unplug the power adapter.** Using a standard screwdriver, carefully pry the Shield Cover (26) off the Left and Right Shields (37, 58).

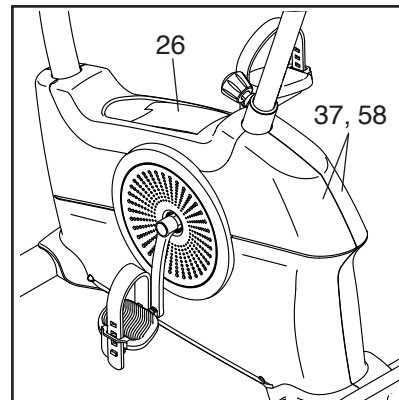

Next, locate the Reed Switch (23). Slightly loosen the M4 x 19mm Screw (50).

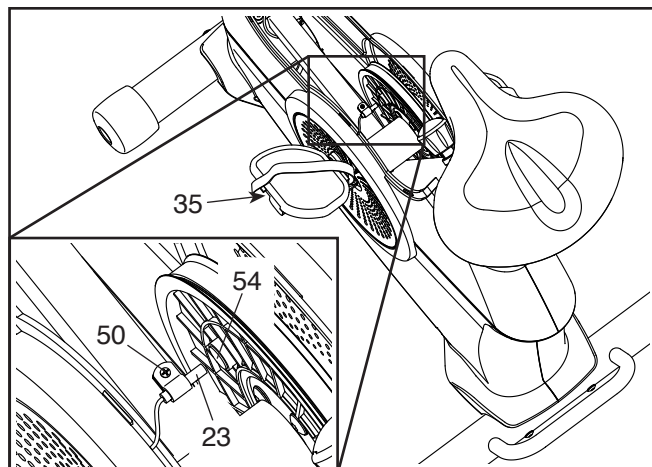

Next, rotate the Left Crank Arm (35) until a Magnet (54) is aligned with the Reed Switch (23). Slide the Reed Switch slightly toward or away from the Magnet. Then, retighten the M4 x 19mm Screw (50).

Plug in the power adapter and rotate the Left Crank Arm (35) for a moment. Repeat these actions until the console displays correct feedback.

When the reed switch is correctly adjusted, reattach the shield cover.

HOW TO ADJUST THE DRIVE BELT

If you can feel the pedals slip while you are pedaling, even when the resistance is adjusted to the highest level, the drive belt may need to be adjusted.

To adjust the drive belt, **first unplug the power adapter**. Next, carefully tip the exercise bike onto its left side as shown.

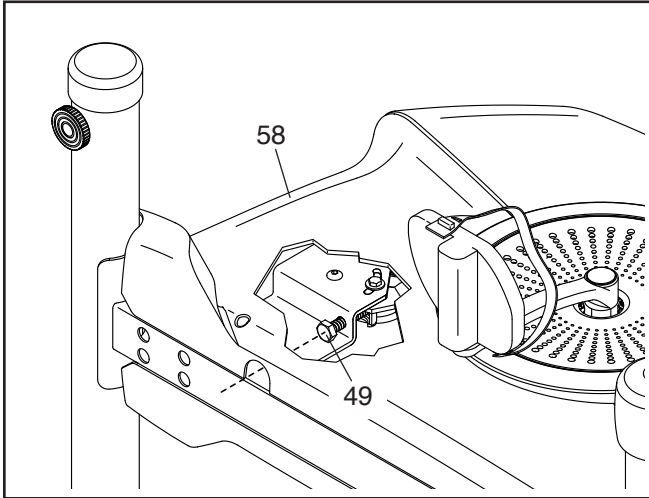

Using an M10 socket wrench with an extension (not included), reach into the opening in the bottom of the Right Shield (58) and tighten the M10 x 50mm Screw (49) a few turns until the Drive Belt (not shown) is tight; **do not overtighten the Drive Belt**.

Then, tip the exercise bike upright, plug in the power adapter, and pedal the exercise bike to test the drive belt. Repeat this process, if necessary, until the pedals no longer slip.

EXERCISE GUIDELINES

⚠️ WARNING: Before beginning this or any exercise program, consult your physician. This is especially important for persons over age 35 or persons with pre-existing health problems.

These guidelines will help you to plan your exercise program. For detailed exercise information, obtain a reputable book or consult your physician. Remember, proper nutrition and adequate rest are essential for successful results.

EXERCISE INTENSITY

Whether your goal is to burn fat or to strengthen your cardiovascular system, exercising at the proper intensity is the key to achieving results. You can use your heart rate as a guide to find the proper intensity level. The chart below shows recommended heart rates for fat burning and aerobic exercise.

165	155	145	140	130	125	115	♥️
145	138	130	125	118	110	103	♥️
125	120	115	110	105	95	90	♥️
<hr/>							
20	30	40	50	60	70	80	

To find the proper intensity level, find your age at the bottom of the chart (ages are rounded off to the nearest ten years). The three numbers listed above your age define your “training zone.” The lowest number is the heart rate for fat burning, the middle number is the heart rate for maximum fat burning, and the highest number is the heart rate for aerobic exercise.

Burning Fat—To burn fat effectively, you must exercise at a low intensity level for a sustained period of time. During the first few minutes of exercise, your body uses carbohydrate calories for energy. Only after the first few minutes of exercise does your body begin to use stored fat calories for energy. If your goal is to burn fat, adjust the intensity of your exercise until your heart rate is near the lowest number in your training zone. For maximum fat burning, exercise with your heart rate near the middle number in your training zone.

Aerobic Exercise—If your goal is to strengthen your cardiovascular system, you must perform aerobic exercise, which is activity that requires large amounts of oxygen for prolonged periods of time. For aerobic exercise, adjust the intensity of your exercise until your heart rate is near the highest number in your training zone.

HOW TO MEASURE YOUR HEART RATE

To measure your heart rate, exercise for at least four minutes. Then, stop exercising and place two fingers on your wrist as shown. Take a six-second heartbeat count, and multiply the result by 10 to find your heart rate. For example, if your six-second heartbeat count is 14, your heart rate is 140 beats per minute.

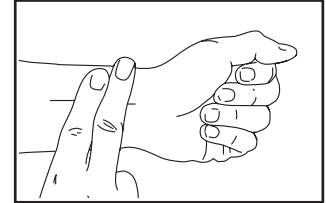

WORKOUT GUIDELINES

Warming Up—Start with 5 to 10 minutes of stretching and light exercise. A warm-up increases your body temperature, heart rate, and circulation in preparation for exercise.

Training Zone Exercise—Exercise for 20 to 30 minutes with your heart rate in your training zone. (During the first few weeks of your exercise program, do not keep your heart rate in your training zone for longer than 20 minutes.) Breathe regularly and deeply as you exercise; never hold your breath.

Cooling Down—Finish with 5 to 10 minutes of stretching. Stretching increases the flexibility of your muscles and helps to prevent post-exercise problems.

EXERCISE FREQUENCY

To maintain or improve your condition, complete three workouts each week, with at least one day of rest between workouts. After a few months of regular exercise, you may complete up to five workouts each week, if desired. Remember, the key to success is to make exercise a regular and enjoyable part of your everyday life.

PART LIST

Model No. PFEX32925-INT.0 R0724A

Key No.	Qty.	Description	Key No.	Qty.	Description
1	1	Frame	34	2	Crank Nut
2	2	M4 x 16mm Screw	35	1	Left Crank Arm
3	1	Console Cover	36	4	M4 x 19mm Self-tapping Screw
4	1	Handlebar	37	1	Left Shield
5	2	Handlebar Cap	38	2	Snap Ring
6	2	Wheel	39	2	Bearing
7	1	Console	40	4	M4 x 12mm Screw
8	1	Front Stabilizer	41	1	Resistance Cable
9	3	Fastener	42	1	Resistance Motor
10	1	M4 x 19mm Bright Screw	43	2	Stabilizer Cap
11	1	Clamp	44	1	Rear Stabilizer
12	1	Seat	45	2	Leveling Foot
13	2	Carriage Cap	46	4	M8 x 70mm Screw
14	1	Seat Bracket	47	2	M10 Flange Nut
15	1	Seat Carriage	48	1	Eddy Mechanism
16	8	M8 Split Washer	49	1	M10 x 50mm Screw
17	10	M8 Locknut	50	2	M4 x 19mm Screw
18	1	Seat Post	51	1	Idler
19	1	Seat Knob	52	1	M6 Washer
20	2	#8 x 3/4" Screw	53	1	M6 x 20mm Screw
21	1	Seat Post Bushing	54	2	Magnet
22	1	Seat Post Cap	55	1	Pulley
23	1	Reed Switch/Wire	56	1	Crank
24	2	M8 x 58mm Bolt	57	1	Drive Belt
25	1	Main Wire	58	1	Right Shield
26	1	Shield Cover	59	1	Right Crank Arm
27	1	Upright	60	1	Right Pedal/Strap
28	1	Seat Post Knob	61	2	M10 x 41mm Screw
29	9	M8 x 20mm Screw	62	4	Mushroom Fastener/Screw
30	1	Power Adapter	63	4	M6 x 16mm Screw
31	1	Power Receptacle/Wire	*	–	Assembly/Adjustment Tool Kit
32	1	Left Pedal/Strap	*	–	User's Manual
33	2	Crank Cap			

Note: Specifications are subject to change without notice. For information about ordering replacement parts, see the back cover of this manual. *These parts are not illustrated.

EXPLODED DRAWING

Model No. PFEX32925-INT.0 R0724A

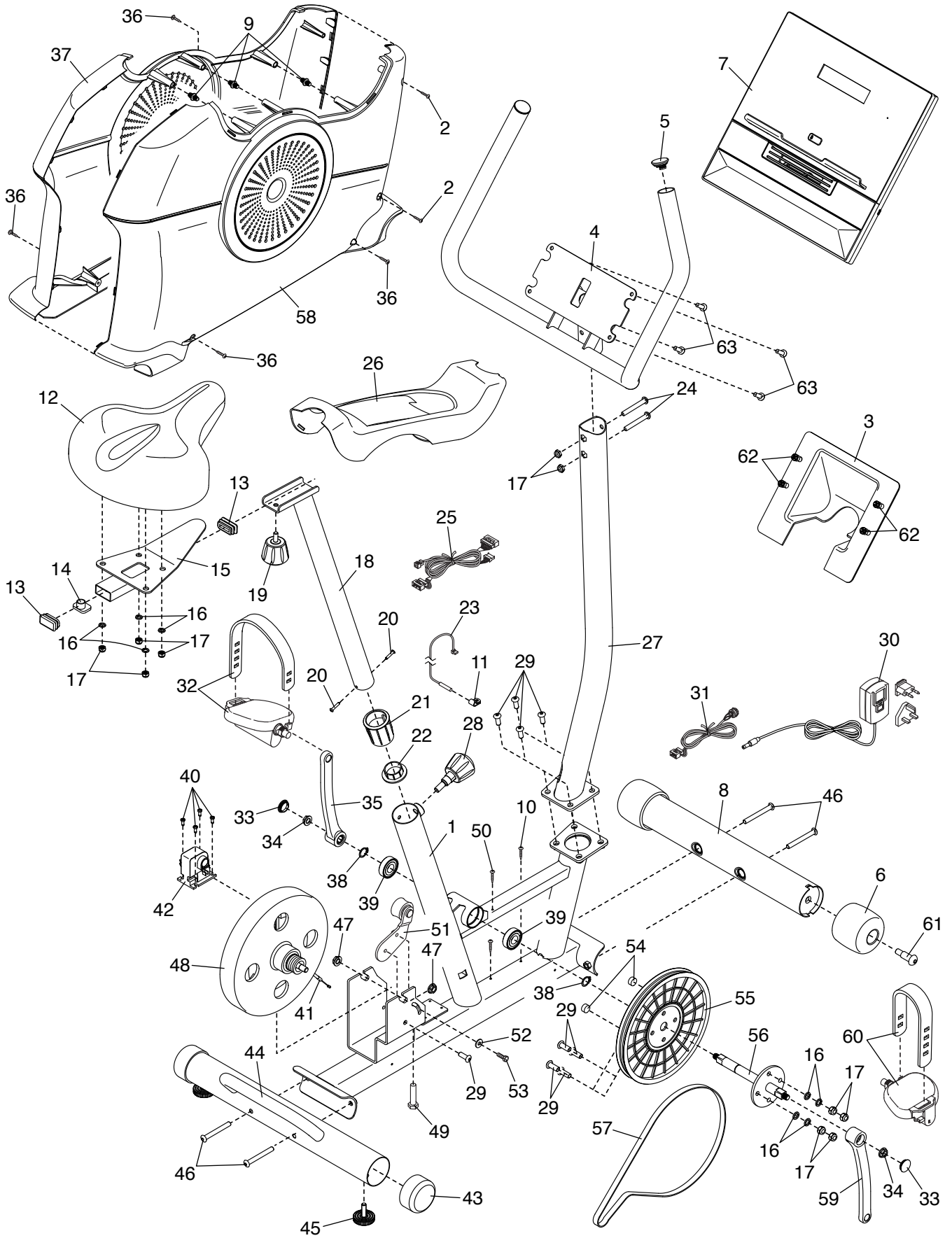

ORDERING REPLACEMENT PARTS

To order replacement parts, please see the front cover of this manual. To help us assist you, be prepared to provide the following information when contacting us:

- the model number and serial number of the product (see the front cover of this manual)
- the name of the product (see the front cover of this manual)
- the key number and description of the replacement part(s) (see the PART LIST and the EXPLODED DRAWING near the end of this manual)

RECYCLING INFORMATION

This electronic product must not be disposed of in municipal waste. To preserve the environment, this product must be recycled after its useful life as required by law.

Please use recycling facilities that are authorized to collect this type of waste in your area. In doing so, you will help to conserve natural resources and improve European standards of environmental protection. If you require more information about safe and correct disposal methods, please contact your local city office or the establishment where you purchased this product.

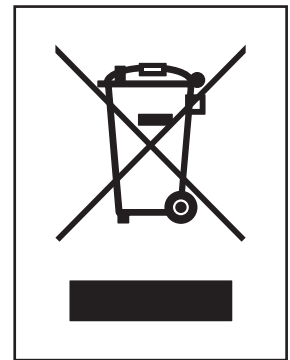

UK/EU DECLARATION OF CONFORMITY

PFEX32925-INT contains the BMD-ICN-1 Bluetooth module.

Hereby, iFIT Health & Fitness declares that the radio equipment type BMD-ICN-1 is in compliance with Directive 2014/53/EU and Radio Equipment Regulation 2017.

iFIT Health & Fitness, 1500 S 1000 W, Logan, UT 84320, USA

This declaration of conformity is issued under the sole responsibility of the manufacturer.

Object of the declaration: FCCID OMCBMD1 - Broadcast Frequency: 2.402GHz to 2.480GHz Transmit Power: +4dBm

Certification: Article 3.1a - Safety EN 62479:2010, EN 62368-1:2014/AC:2015, Article 3.1b – EMC EN 301 489-17 V3.2.4, Article 3.2 – Radio parameters EN 300 328 V2.2.2

UK Representative: ICON Health & Fitness Ltd, Unit 1D The Gateway, Fryers Way, Silkwood Park, Ossett, WF5 9TJ, United Kingdom

EU Representative: iFIT Health & Fitness SAS Business Park, 5 rue Alfred de Vigny
78112 Fourqueux, France

