

NordicTrack®

T SERIES 10

Model No. NTL15425-INT.3

Serial No. _____

Write the serial number in the space above for reference.

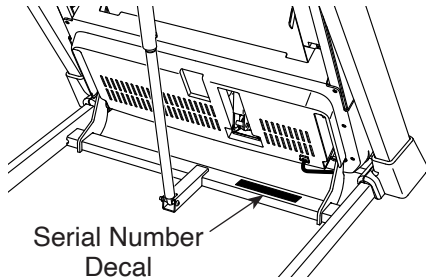

UNITED KINGDOM

Website: iFITsupport.eu

E-mail: csuk@iconeurope.com

Write:

iFIT Health & Fitness Limited
Unit 4, Westgate Court
Silkwood Park
OSSETT
WF5 9TT
UNITED KINGDOM

AUSTRALIA

Call: 1800 993 770

E-mail: australiacc@iFIT.com

Write:

iFIT Inc.
PO Box 635
WINSTON HILLS NSW 2153
AUSTRALIA

USER'S MANUAL

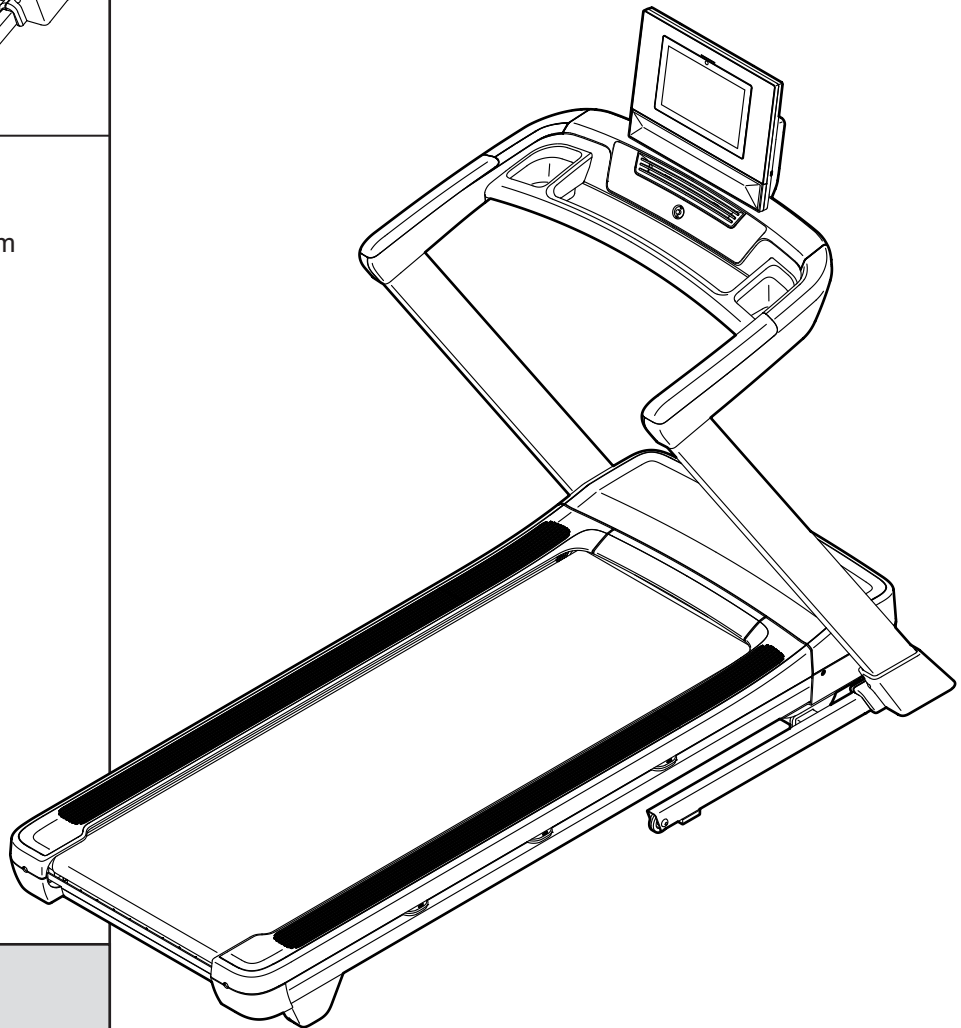

CAUTION

Read all precautions and instructions in this manual before using this equipment. Keep this manual for future reference.

TABLE OF CONTENTS

WARNING DECAL PLACEMENT 2

IMPORTANT PRECAUTIONS 3

BEFORE YOU BEGIN 5

PART IDENTIFICATION CHART 6

ASSEMBLY 7

HOW TO PLUG IN THE POWER CORD 15

HOW TO USE THE TREADMILL 16

HOW TO FOLD AND MOVE THE TREADMILL 25

MAINTENANCE AND TROUBLESHOOTING 26

EXERCISE GUIDELINES 29

PART LIST 30

EXPLODED DRAWING 32

ORDERING REPLACEMENT PARTS Back Cover

RECYCLING INFORMATION Back Cover

UK/EU DECLARATION OF CONFORMITY Back Cover

WARNING DECAL PLACEMENT

This drawing shows the locations of the warning decals. **If a decal is missing or illegible, see the front cover of this manual and request a free replacement decal. Apply the decal in the location shown.** Note: The decals may not be shown at actual size.

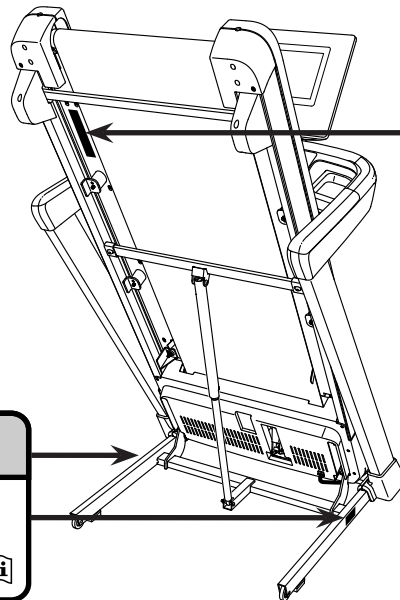

WARNING

To reduce the risk of serious injury, read user's manual and:

- Stand only on foot rails when starting or stopping.
- Never allow children on or around.
- Keep clothing, fingers, and hair away from moving parts.
- Change speed in small increments.
- Hold handrails to reduce risk of falling.
- Always wear clip while operating.
- Stop if you feel faint, dizzy, or short of breath.
- Set incline to zero before folding (power incline only).
- Fully engage the safety latch before moving or storing.
- Always remove key when not in use.
- Never adjust or fix the belt while it is moving.
- Always wear athletic shoes while operating. ⓘ

NORDICTRACK and IFIT are registered trademarks of iFIT Inc. The Bluetooth® word mark and logos are registered trademarks of Bluetooth SIG, Inc. and are used under license. Google Maps is a trademark of Google LLC. Wi-Fi is a registered trademark of Wi-Fi Alliance. WPA and WPA2 are trademarks of Wi-Fi Alliance.

IMPORTANT PRECAUTIONS

⚠️ WARNING: To reduce the risk of burns, fire, electric shock, or injury to persons, read all important precautions and instructions in this manual and all warnings on your treadmill before using your treadmill. iFIT assumes no responsibility for personal injury or property damage sustained by or through the use of this product.

1. It is the responsibility of the owner to ensure that all users of the treadmill are adequately informed of all warnings and precautions.
2. Keep children under age 16 and pets away from the treadmill at all times.
3. Consult your health care provider before beginning any exercise program. This is especially important for persons over age 35 or persons with pre-existing health problems.
4. Consult your health care provider before beginning or continuing any exercise program during pregnancy. Use the treadmill only as authorized by your health care provider.
5. The treadmill is not intended for use by persons with reduced physical, sensory, or mental capabilities or lack of experience and knowledge, unless they have been given supervision or instruction concerning the use of the treadmill by someone responsible for their safety.
6. Use the treadmill only as described in this manual.
7. The treadmill is intended for home use only. Do not use the treadmill in any commercial, rental, or institutional setting.
8. Keep the treadmill indoors, away from moisture and dust. Do not put the treadmill in a garage or covered patio, or near water.
9. Place the treadmill on a level surface, with at least 8 ft. (2.4 m) of clearance behind it and 2 ft. (0.6 m) on each side. Do not place the treadmill on any surface that blocks air openings. To protect the floor or carpet from damage, place a mat under the treadmill.
10. Do not operate the treadmill where aerosol products are used or where oxygen is being administered.
11. The treadmill should be used only by persons weighing 325 lbs. (148 kg) or less.
12. Never allow more than one person on the treadmill at a time.
13. Wear appropriate exercise clothes while using the treadmill. Do not wear loose clothes that could become caught in the treadmill. Athletic support clothes are recommended for both men and women. Always wear athletic shoes. Never use the treadmill with bare feet, wearing only stockings, or in sandals.
14. When connecting the power cord (see page 15), plug the power cord into an earthed circuit. No other appliance should be on the same circuit. When replacing the fuse in the power cord adapter, insert an ASTA-approved BS1362, 13-amp fuse into the fuse carrier.
15. If an extension cord is needed, use only a 3-conductor, 14-gauge (2 mm²) cord that is no longer than 5 ft. (1.5 m).
16. Keep the power cord away from heated surfaces.
17. Never move the walking belt while the power is turned off. Do not operate the treadmill if the power cord or plug is damaged, or if the treadmill is not working properly. (See MAINTENANCE AND TROUBLESHOOTING on page 27 if the treadmill is not working properly.)
18. Read, understand, and test the emergency stop procedure before using the treadmill (see HOW TO TURN ON THE CONSOLE on page 17). Always wear the clip while using the treadmill.
19. Be careful when mounting and dismounting the treadmill. Always stand on the foot rails when starting or stopping the walking belt. Always hold the handrails while using the treadmill.

20. When a person is walking on the treadmill, the noise level of the treadmill will increase.
21. Keep fingers, hair, and clothing away from the moving walking belt.
22. The treadmill is capable of high speeds. Adjust the speed in small increments to avoid sudden jumps in speed.
23. Never leave the treadmill unattended while it is running. Always remove the key, press the power switch into the off position (see the drawing on page 5 for the location of the power switch), and unplug the power cord when the treadmill is not in use.
24. Do not attempt to move the treadmill until it is properly assembled. (See ASSEMBLY on page 7 and HOW TO FOLD AND MOVE THE TREADMILL on page 26.) You must be able to safely lift 45 lbs. (20 kg) to move the treadmill.
25. When folding or moving the treadmill, make sure that the storage latch is holding the frame securely in the storage position. Do not operate the treadmill while it is folded.
26. Do not change the incline of the treadmill by placing objects under the treadmill.
27. Never insert any object into any opening on the treadmill.
28. Inspect and properly tighten all parts each time the treadmill is used. Replace any worn parts immediately. Use only manufacturer-supplied parts.
29. **DANGER:** Always unplug the power cord immediately after use, before cleaning the treadmill, and before performing the maintenance and adjustment procedures described in this manual. Never remove the motor hood unless instructed to do so by an authorized service representative. Servicing other than the procedures in this manual should be performed by an authorized service representative only.
30. Over exercising may result in serious injury or death. If you feel faint, if you become short of breath, or if you experience pain while exercising, stop immediately and cool down.

SAVE THESE INSTRUCTIONS

BEFORE YOU BEGIN

Thank you for selecting the new NORDICTRACK® T SERIES 10 treadmill. The T SERIES 10 treadmill provides an impressive selection of features designed to make your workouts at home more effective and enjoyable.

For your benefit, read this manual carefully before you use the treadmill. If you have questions after

reading this manual, please see the front cover of this manual. To help us assist you, note the product model number and serial number before contacting us (see the front cover of this manual).

Before reading further, please familiarize yourself with the parts that are labeled in the drawing below.

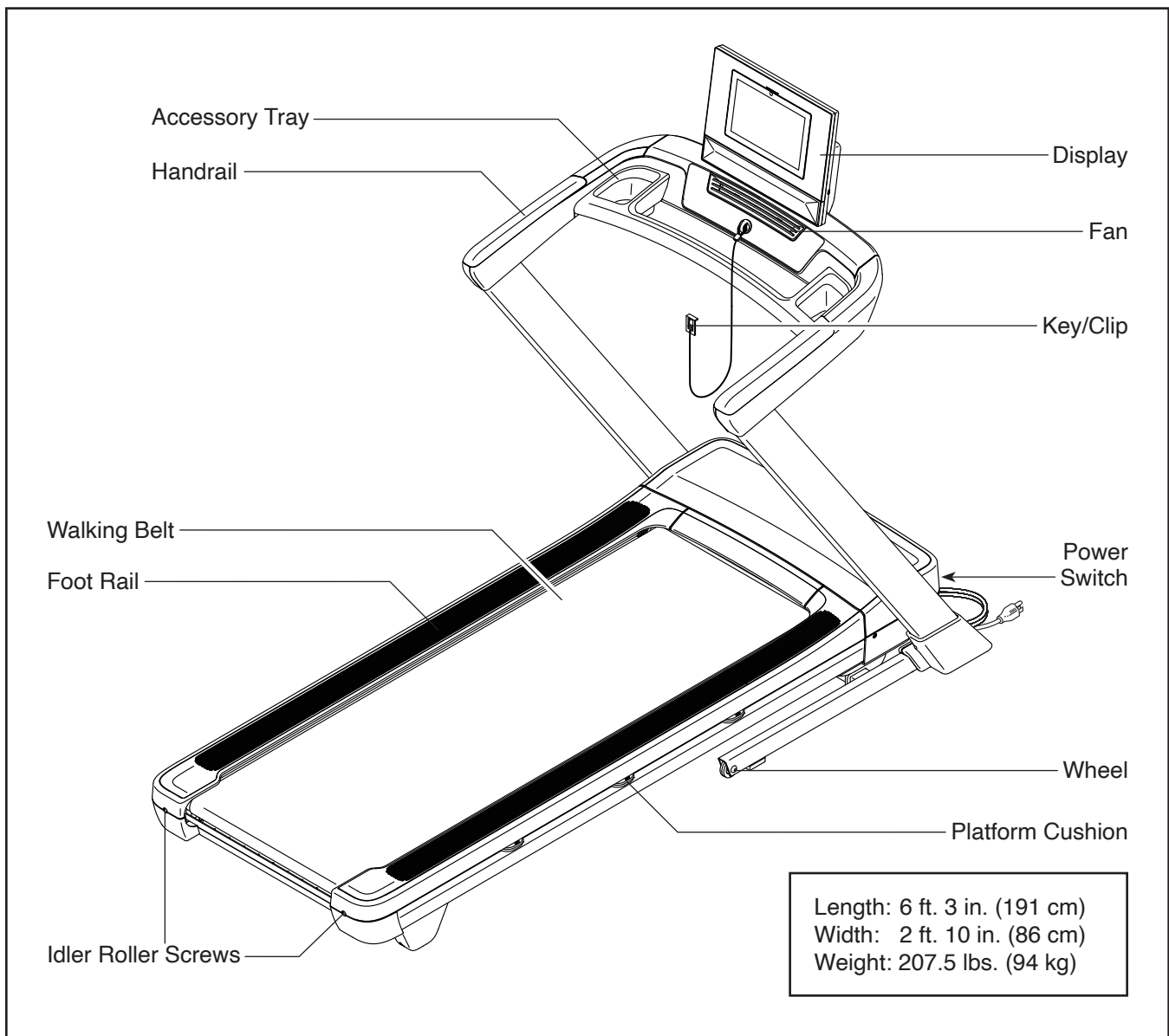

PART IDENTIFICATION CHART

Use the drawings below to identify small parts used for assembly. The number in parentheses below each drawing is the key number of the part, from the PART LIST near the end of this manual. The number after the key number is the quantity used for assembly. **Note: If a part is not in the hardware kit, check to see whether it is preattached. Extra parts may be included.**

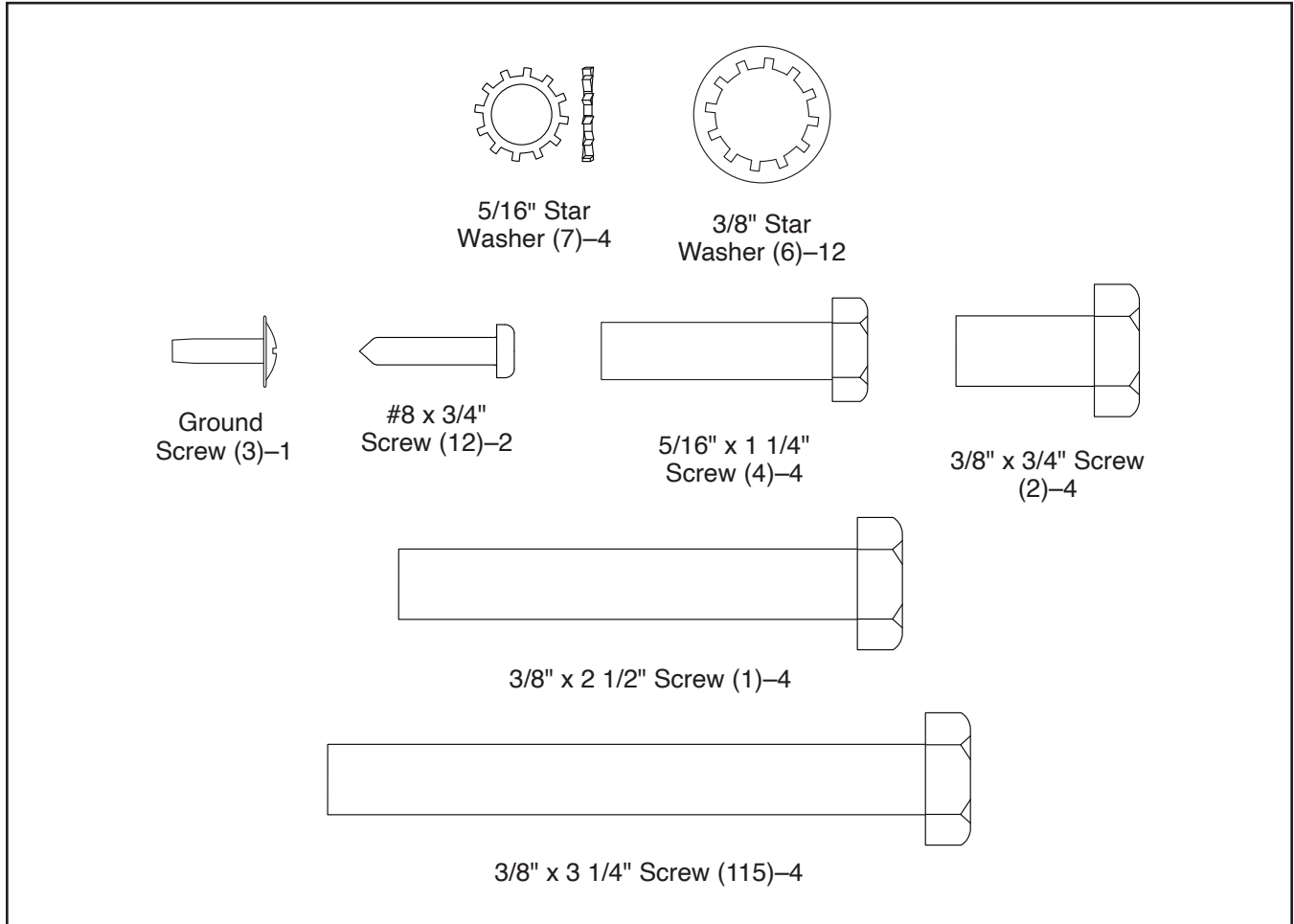

ASSEMBLY

- Assembly requires two persons.
- Place all parts in a cleared area and remove the packing materials. Do not dispose of the packing materials until you finish all assembly steps.
- After shipping, there may be an oily substance on the exterior of the treadmill. This is normal. If there is an oily substance on the treadmill, wipe it off with a soft cloth and a mild, non-abrasive cleaner.
- Left parts are marked “L” or “Left” and right parts are marked “R” or “Right.”
- To identify small parts, see page 6.
- Assembly can be completed using the included tools. Note: Keep the included tools. One or more of the tools may be needed to make adjustments in the future. To avoid damaging parts, do not use power tools for assembly or adjustment.

1. **To register your product and activate your warranty in the UK**, go to iFITsupport.eu. If you do not have internet access, complete the warranty registration card in the warranty booklet and send it by registered post to the address on the back cover of the warranty booklet.

To register your product and activate your warranty in Australia, email or post the following information to the email address or postal address on the front cover of this manual.

- your receipt (make sure to keep a copy)
- your name, address, and telephone number
- the model number, serial number, and name of your product (see the front cover of this manual)

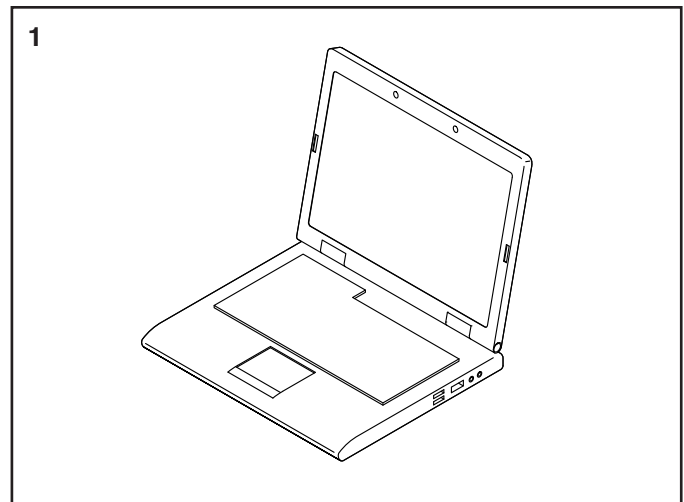

2. Make sure that the power cord is unplugged.

Identify the Right Upright (85) and the Right Base Cover (89), **orient them as shown**, and slide the Right Base Cover onto the Right Upright.

Slide the Left Base Cover (not shown) onto the Left Upright (not shown) in the same way.

Next, remove the tie securing the Upright Wire (82) on the right side of the Base (94).

See the inset drawing. Locate the wire tie (A) in the Right Upright (85). Tie the wire tie through the wire pull (B) on the Upright Wire (82). Then, insert the wire pull and the Upright Wire into the Right Upright.

Then, pull the upper end of the wire tie (A) until the Upright Wire (82) is routed through the Right Upright (85). **Do not untie the wire tie yet.**

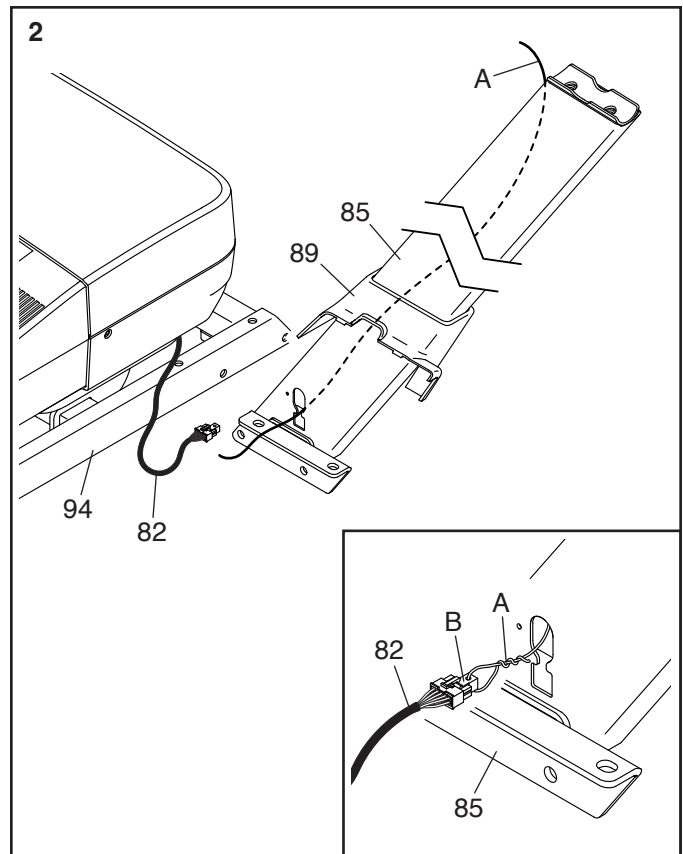

3. Remove and discard the indicated screw (C) in the Right Upright (85). Then, attach the ground wire (D) to the Right Upright with a Ground Screw (3).

See the inset drawing. Locate the small ear (E) on the Grommet (86) on the Upright Wire (82). Insert the ear into the square hole (F) in the Right Upright (85), and then press the Grommet into the square hole.

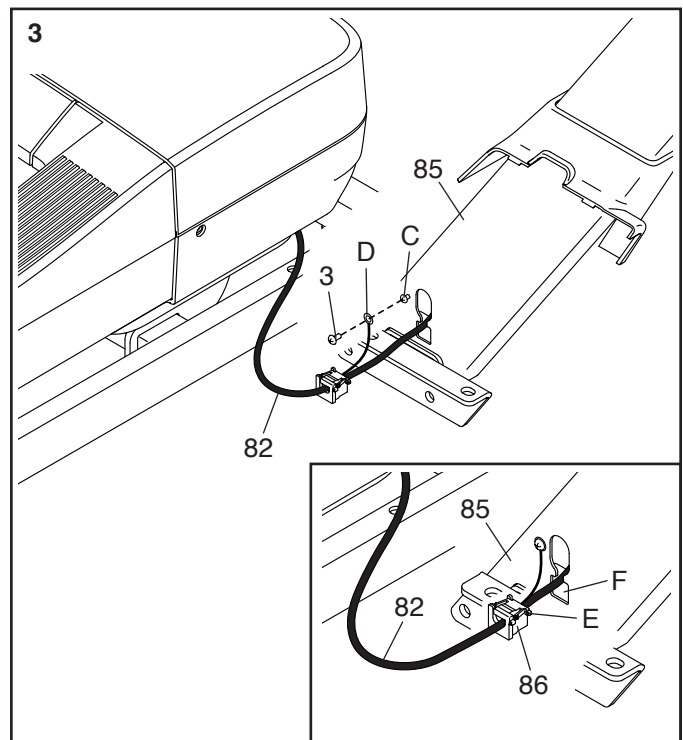

4. Have a second person hold the Right Upright (85) against the Base (94).

Insert two 3/8" x 3/4" Screws (2) with two 3/8" Star Washers (6) into the top of the bracket on the Right Upright (85), and partially tighten the Screws into the Base (94); **do not fully tighten the Screws yet.**

Finish attaching the Right Upright (85) with two 3/8" x 2 1/2" Screws (1) and two 3/8" Star Washers (6); **do not fully tighten the Screws yet.**

Attach the Left Upright (not shown) in the same way.

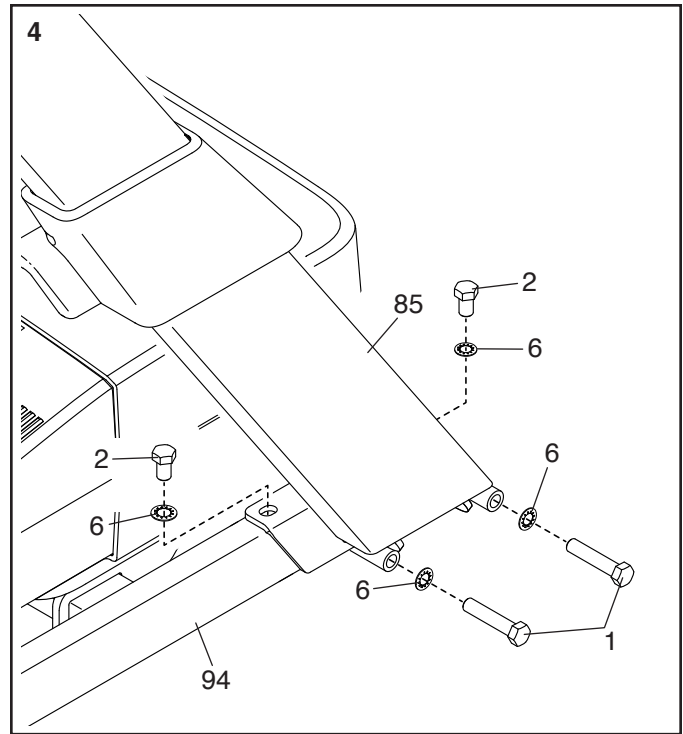

5. **Do not pinch the Upright Wire (82) during this step.** With the help of a second person, hold the handrail assembly (G) on the Left and Right Uprights (84, 85). Attach the handrail assembly with four 3/8" x 3 1/4" Screws (115) and four 3/8" Star Washers (6); **start all four Screws, and then tighten them.**

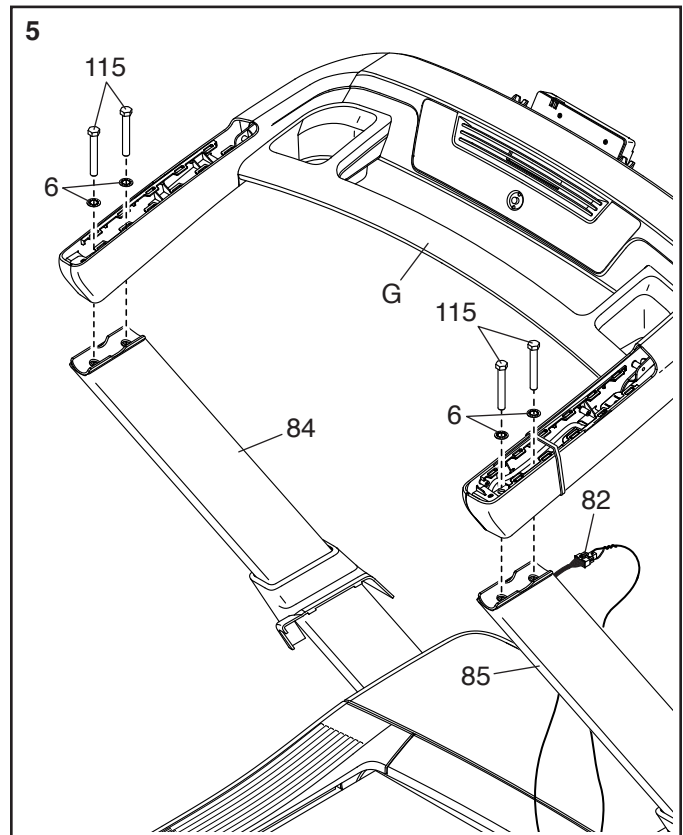

6. **See the inset drawing.** Press the small latch (H) on the connector on the Upright Wire (82), and remove and discard the wire pull (B). Then, cut and discard the plastic tie (I) securing the Handrail Wire (83).

Next, connect the Upright Wire (82) to the Handrail Wire (83). **IMPORTANT: The wire connectors should slide together easily and snap into place with an audible click. You must connect the wires properly for your treadmill to function properly.**

Then, insert the connectors and the excess wire into the Right Upright (85).

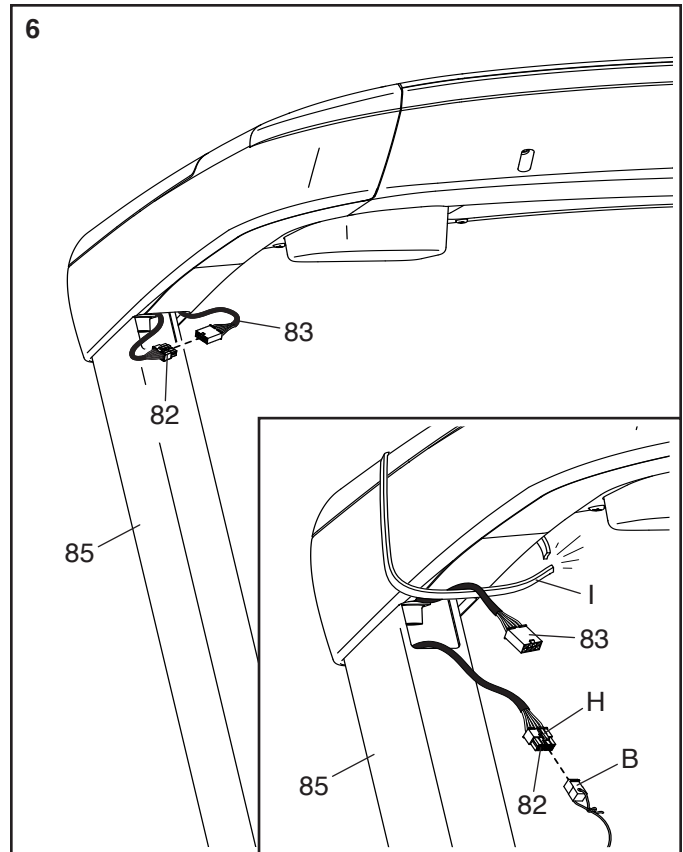

7. Identify the Right Handrail Cover (75). Insert the front edge of the Right Handrail Cover into the top of the handrail assembly (G) as shown. Then, press down on the top of the Right Handrail Cover until it snaps into place.

Attach the Left Handrail Cover (74) to the handrail assembly (G) in the same way.

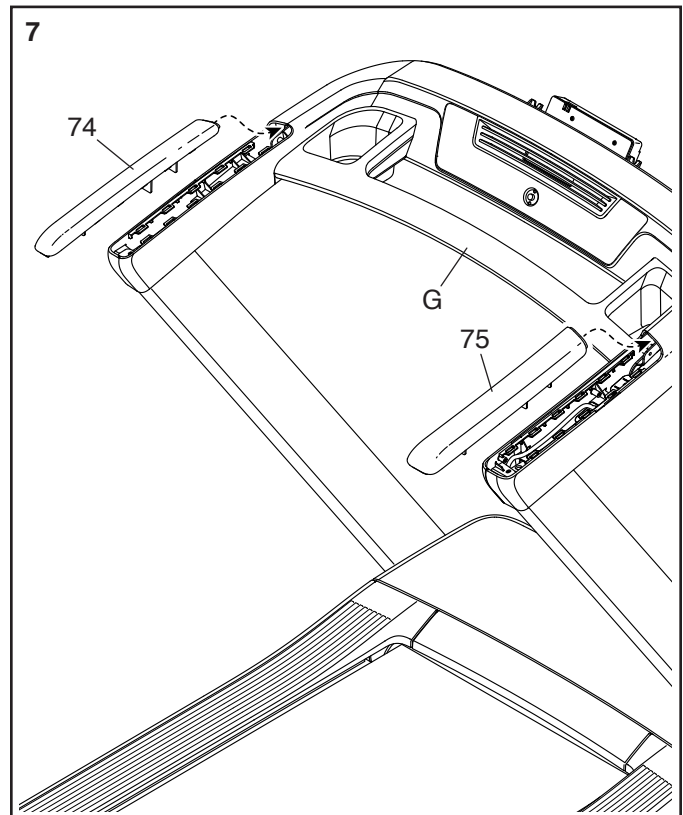

8. Do not pinch any wires during this step.

Have a second person hold the display assembly (J) in the location shown.

See the inset drawing. Locate the two Mounting Spacers (100) on the Display Frame (97). Have the second person slide the Display Frame onto the Handrail Frame (81), with the Mounting Spacers in the indicated slots (K).

Attach the Display Frame (97) with four 5/16" x 1 1/4" Screws (4) and four 5/16" Star Washers (7); **start all four Screws, and then tighten them.**

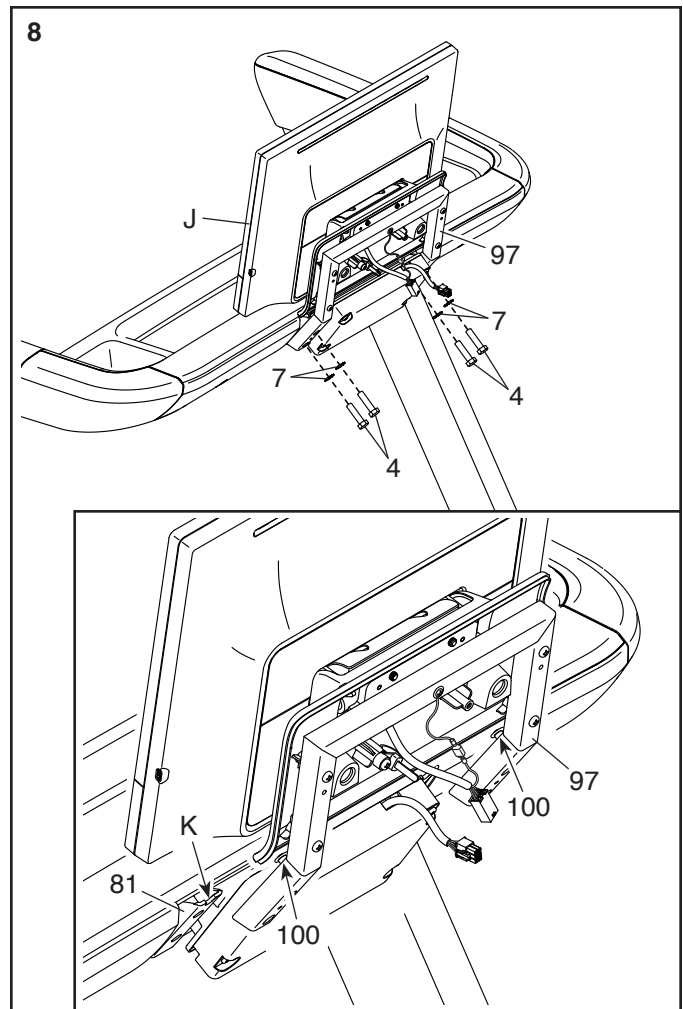

9. Connect the display wire (N) to the wire (O) extending from the Circuit Board Cover (50). IMPORTANT: The wire connectors should slide together easily and snap into place with an audible click. You must connect the wires properly for your treadmill to function properly.

Then, route the display wire (N) through the indicated Cable Tie (105), close the Cable Tie, and cut off the end of the Cable Tie.

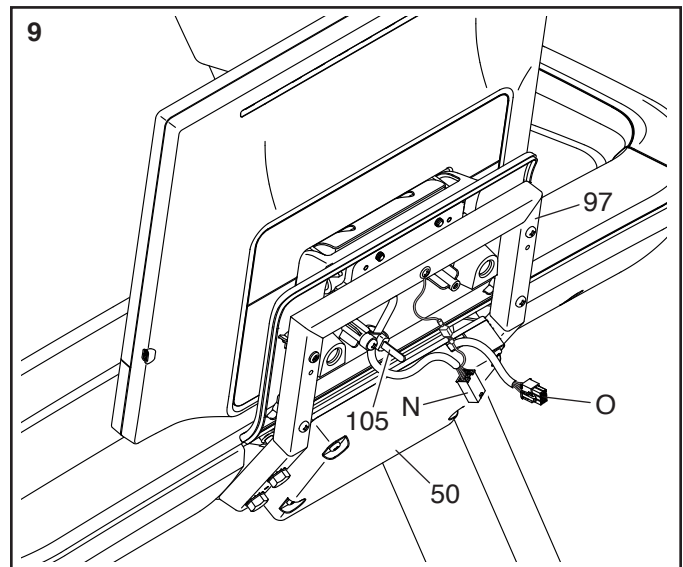

10. Do not pinch the wires during this step.

Attach the Large Pivot Cover (102) to the Display Frame (97) with two #8 x 3/4" Screws (12).

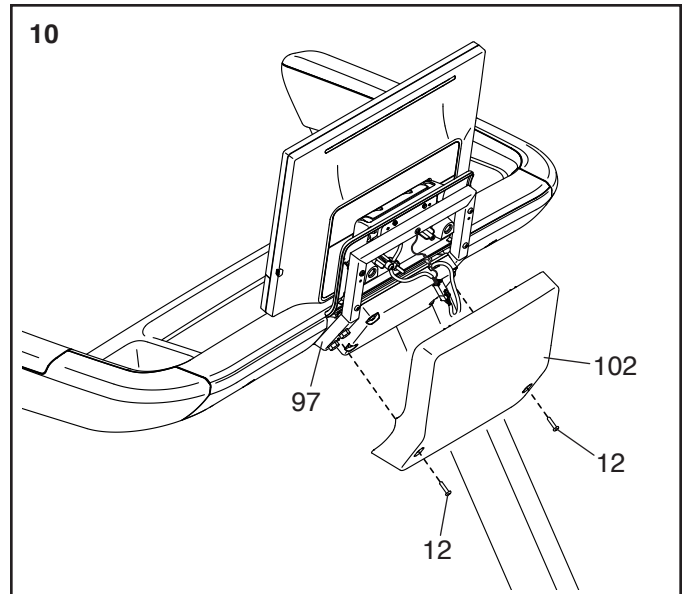

11. Raise the Frame (57) to the position shown. IMPORTANT: Have a second person hold the Frame until step 13 is completed.

See the inset drawing. Remove the two 5/16" x 3/4" Screws (8) from the Latch Crossbar (53).

Then, orient the Latch Crossbar (53) as shown, with the “This side toward belt” sticker (R) facing the treadmill. Attach the Latch Crossbar to the Frame (57) with the two 5/16" x 3/4" Screws (8) that you just removed.

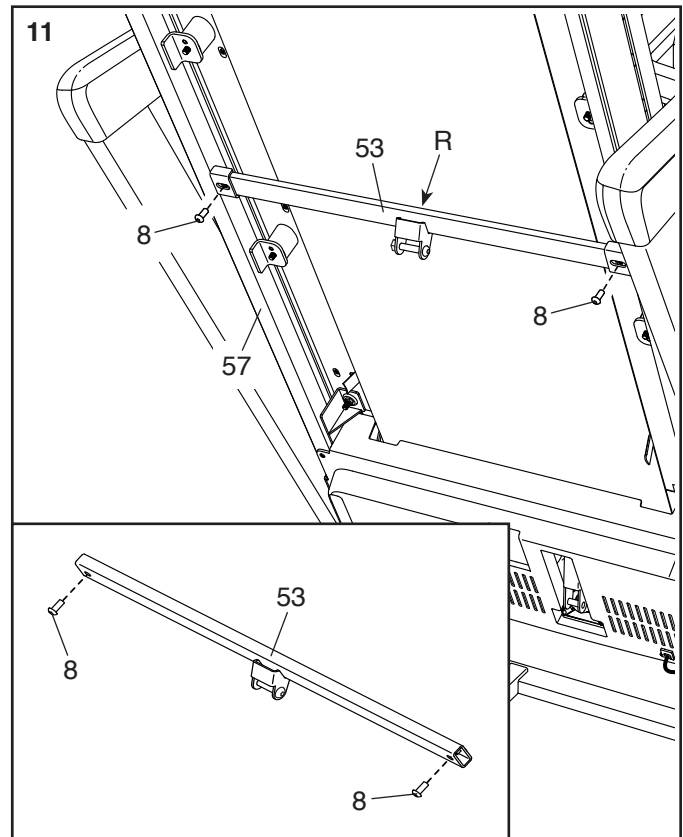

12. Remove the 5/16" Nut (34), the two 3/8" Thrust Washers (29), and the 5/16" x 1 3/4" Bolt (22) from the bracket on the Base (94). **Note: If one of the 5/16" Bushings (108) comes out, reinsert it.**

Next, orient the Storage Latch (56) as shown.

Attach the Storage Latch (56) to the Base (94) with the 5/16" x 1 3/4" Bolt (22), the two 3/8" Thrust Washers (29), and the 5/16" Nut (34) that you just removed.

Then, raise the Storage Latch (56) to a vertical position, and remove the tie (P).

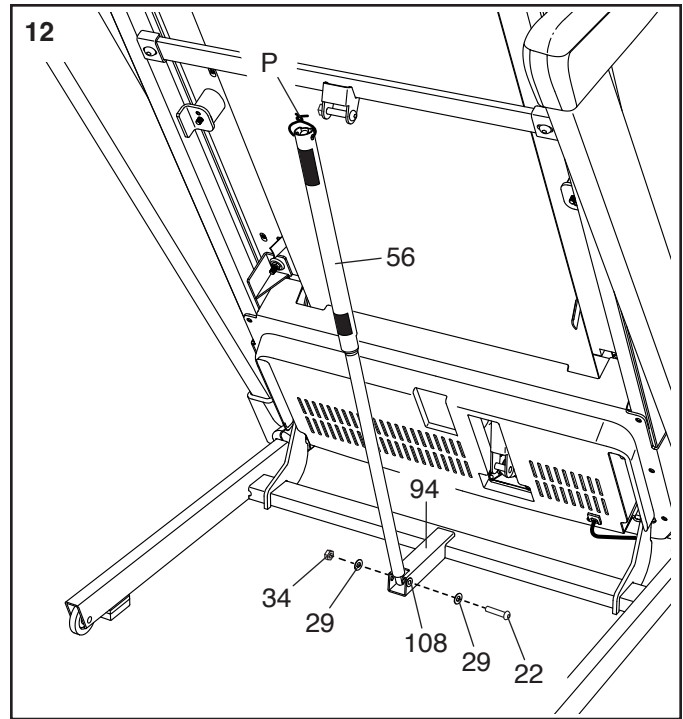

13. Remove the 5/16" Nut (34) and the 5/16" x 2 1/4" Bolt (23) from the bracket on the Latch Crossbar (53).

Next, align the upper end of the Storage Latch (56) with the bracket on the Latch Crossbar (53), and insert the 5/16" x 2 1/4" Bolt (23) through the bracket and the Storage Latch. **This will push a spacer (Q) out of the Storage Latch; discard the spacer. Note: If one of the 5/16" Bushings (108) comes out, reinsert it.**

Next, tighten the 5/16" Nut (34) onto the 5/16" x 2 1/4" Bolt (23). **Do not overtighten the Nut; the Storage Latch (56) must be able to pivot.**

Then, lower the Frame (57) (see HOW TO LOWER THE TREADMILL FOR USE on page 25).

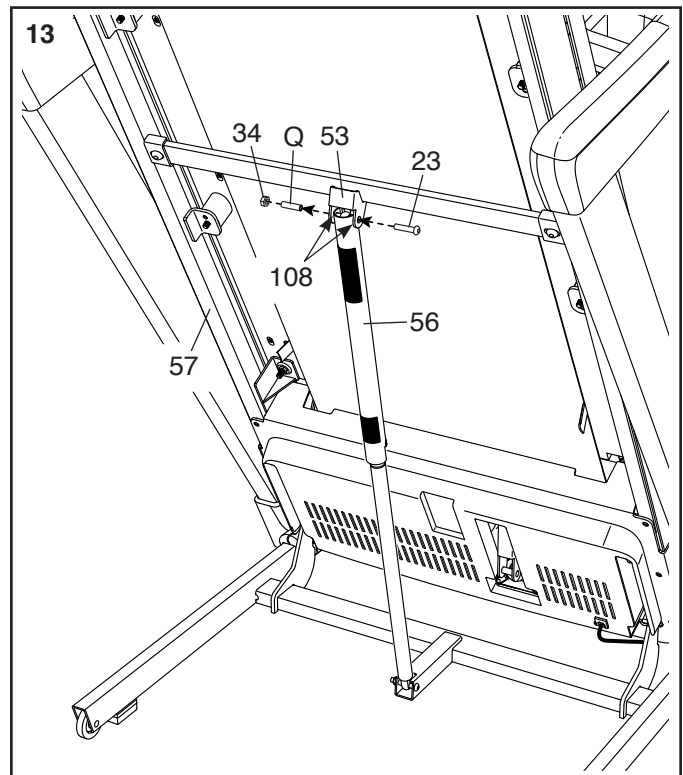

14. Firmly tighten the two 3/8" x 3/4" Screws (2) and the two 3/8" x 2 1/2" Screws (1) in the Right Upright (85).

Repeat this step on the left side of the treadmill.

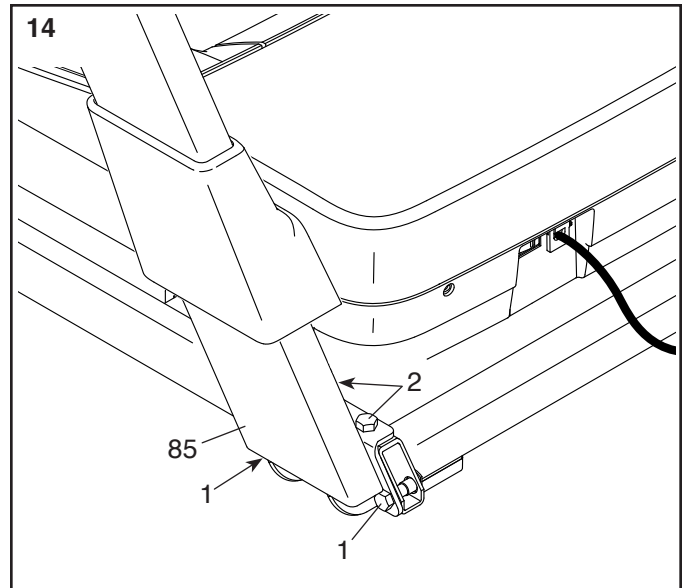

15. Identify the Right Inner Base Cover (91). Slide the Right Inner Base Cover onto the Base (94), under the Upright Wire (82), as shown in the inset drawing. **Make sure that the Upright Wire is in the notch (R) in the Right Inner Base Cover as shown.**

Then, slide the Right Base Cover (89) downward onto the Right Inner Base Cover (91).

Repeat this step on the left side of the treadmill with the Left Inner Base Cover (not shown) and the Left Base Cover (not shown).
Note: There is not a wire on the left side of the treadmill.

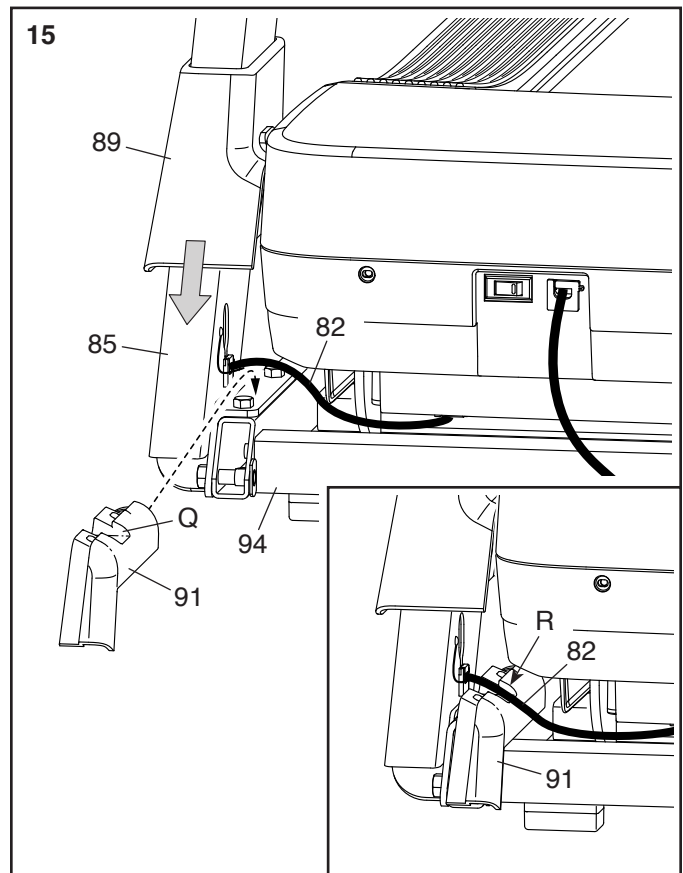

16. **Make sure that all parts are properly tightened before you use the treadmill.** If there are sheets of plastic on the treadmill decals, remove the plastic. To protect the floor or carpet, place a mat under the treadmill. To avoid damage to the console, keep the treadmill out of direct sunlight. Keep the included tools in a secure place; one or more of the tools may be needed to make adjustments to the treadmill in the future. Note: Extra hardware may be included.

HOW TO PLUG IN THE POWER CORD

This product must be earthed. If it should malfunction or break down, earthing provides a path of least resistance for electric current to reduce the risk of electric shock. This product's power cord has an equipment-earthing conductor and an earthing plug. **IMPORTANT: If the power cord is damaged, it must be replaced with a manufacturer-recommended power cord.**

⚠ DANGER: Improper connection of the equipment-earthing conductor can result in an increased risk of electric shock. Check with a qualified electrician or serviceman if you are in doubt as to whether the product is properly earthed. Do not modify the plug provided with the product—if it will not fit the outlet, have a proper outlet installed by a qualified electrician.

Follow the steps below to plug in the power cord.

1. Plug the indicated end of the power cord (A) into the socket (B) on the treadmill.

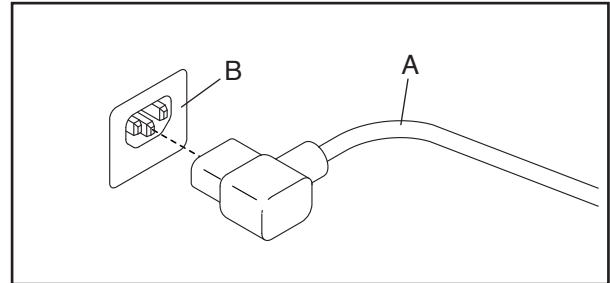

2. Plug the other end of the power cord (A) into an appropriate outlet (C) that is properly installed and earthed in accordance with all local codes and ordinances.

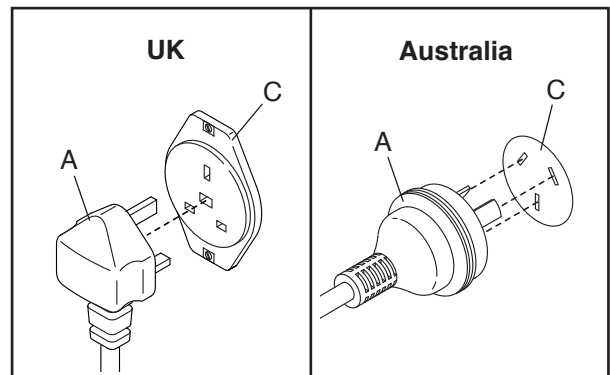

HOW TO USE THE TREADMILL

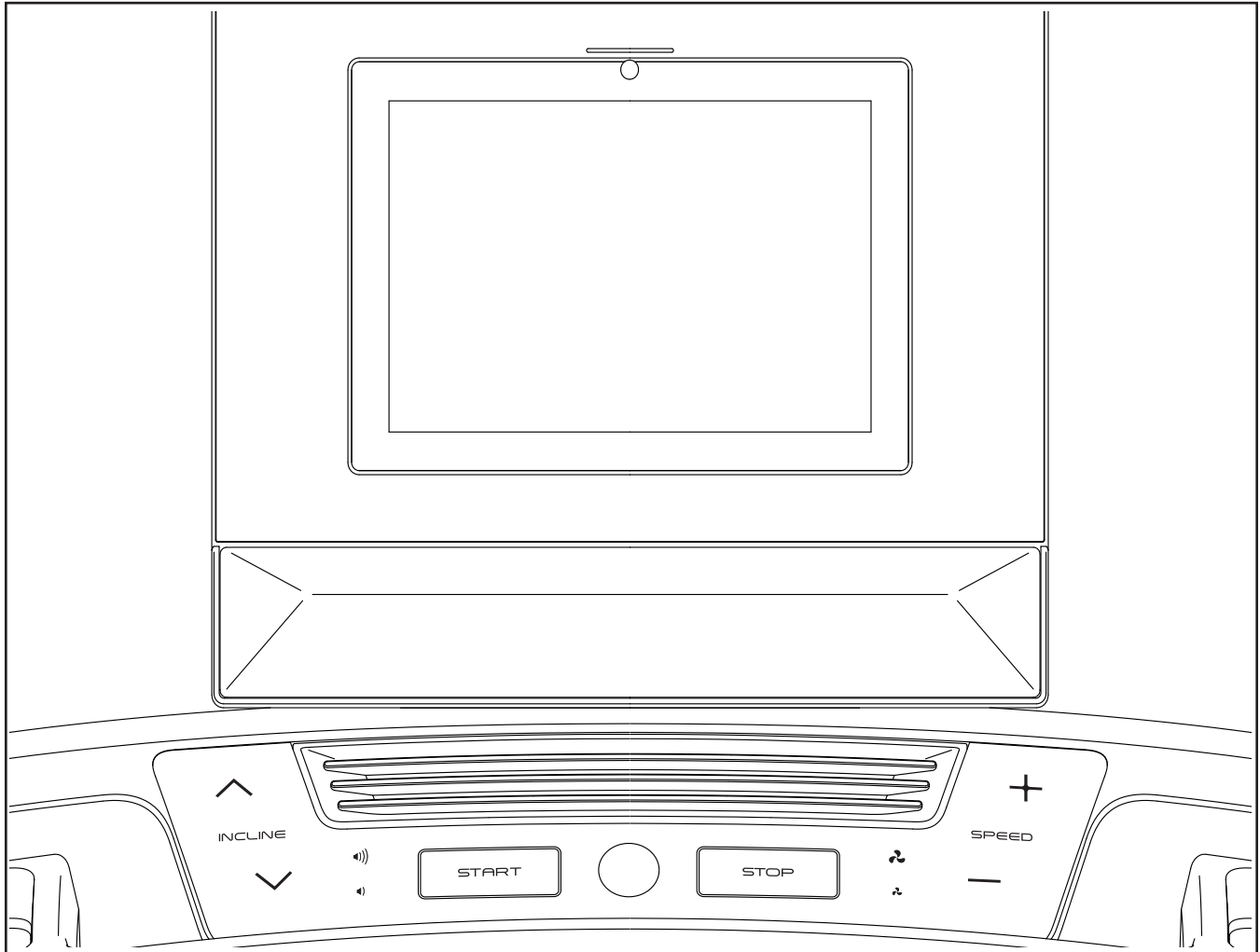

IMPORTANT: iFIT will periodically update your console's software to improve your workout experience. After a software update, some settings and features described in this manual may no longer apply to your console, and your console may have new settings and features. Take time to explore your console's settings and features. **If you have questions, please visit my.iFIT.com or contact Member Care.**

FEATURES OF THE CONSOLE

The advanced console offers a selection of features designed to make your workouts more effective and exciting.

When you use the manual mode of the console, you can change the speed and incline of the treadmill with a touch of a button. As you exercise, the console will display instant exercise feedback.

The console also features wireless technology that enables the console to connect to iFIT®. With iFIT, you can choose from a changing selection of featured workouts that automatically control the speed and incline of the treadmill as iFIT trainers guide you through immersive exercise sessions.

With an iFIT subscription, you can access a library of thousands of on-demand destination and studio workouts, create your own workouts, track your workout results, and access many other features. Go to iFIT.com to learn more.

HOW TO TURN ON THE CONSOLE

IMPORTANT: If the treadmill has been exposed to cold temperatures, allow it to warm to room temperature before you turn on the console. If you do not do this, you may damage electrical components.

Plug in the power cord. Next, locate the power switch on the treadmill frame near the power cord. Press the power switch into the reset position (A).

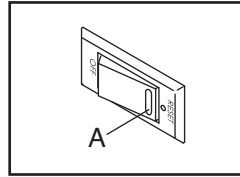

Next, **stand on the foot rails of the treadmill.** Locate the clip (B) attached to the key (C), and slide the clip securely onto the waistband of your clothes. Then, insert the key into the console. **IMPORTANT:** In an emergency, the

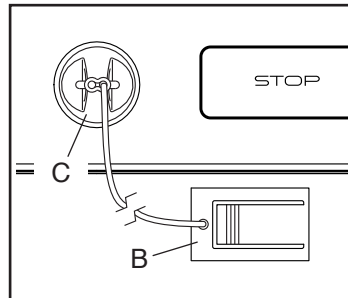

key can be pulled from the console, causing the walking belt to slow to a stop. Test the clip by taking a few steps backward; if the key is not pulled from the console, adjust the position of the clip.

HOW TO TURN OFF THE CONSOLE

When you finish using the treadmill, remove the key from the console and put it in a secure place. Then, press the power switch into the off position and unplug the power cord. **IMPORTANT:** If you do not do this, the electrical components of the treadmill may wear prematurely.

IMPORTANT: To avoid damaging the treadmill, adjust the incline to 0% before you fold the treadmill.

HOW TO USE THE TOUCH SCREEN

The console features an advanced tablet with a full-color touch screen. You can slide or flick your finger against the screen to move images on the screen, such as the displays in a workout. Note: The screen is not pressure sensitive; you do not need to press hard.

To type information into a text box, touch the text box to view the keyboard. To use numbers or other characters, touch **?123**. To view more characters, touch **~<**. To return to the letter keyboard, touch **ABC**. To use a capital character, touch the shift button (upward-facing arrow symbol). To clear text, touch the clear button (backward-facing arrow with an X).

HOW TO SET UP THE CONSOLE

Before you use the treadmill for the first time, set up the console.

1. Choose your time zone.

2. Connect to a wireless network.

To use iFIT workouts and several other features of the console, the console must be connected to a wireless network. If necessary, see page 23 for detailed instructions.

3. Create or sign in to your iFIT account.

Follow the prompts on the screen to create an iFIT account or to log in to your iFIT account. Available subscription options will be shown.

4. Check for software updates.

Touch the console settings button (gear icon) on the screen. Next, touch *Equipment* and then touch *Software update*. Software updates will begin automatically. **IMPORTANT: To avoid damaging the treadmill, do not press the power switch or unplug the power cord while the software is being updated.** See page 22 for detailed instructions.

The console is now ready for you to begin working out. Take a moment to explore the settings and features of the console.

IMPORTANT: To prevent damage to the treadmill, wear clean athletic shoes while using the treadmill. The first time you use the treadmill, observe the alignment of the walking belt, and center it if necessary (see page 28).

HOW TO USE THE MANUAL MODE

1. Select the home screen.

When you turn on the console, the home screen will appear after the console boots up. If you have already selected a workout, touch the screen and follow the prompts to end the workout and return to the home screen.

2. Get ready for the workout.

Touch *Quick start* on the screen or press the Start button on the console. The walking belt will start to move at a slow speed.

To use the fan, your Bluetooth headphones, or an optional heart rate monitor, see page 24.

3. Change the speed of the walking belt as desired.

You can change the speed of the walking belt in the following ways:

Speed buttons on the console—Each time you press a button, the speed setting will change; if you hold down a button, the speed setting will change more quickly.

Numbered speed buttons on the right side of the screen—Each time you touch a button, the walking belt will gradually change speed until it reaches the selected speed setting.

Note: To turn on and turn off the numbered speed buttons on the screen, touch the workout settings icon in the lower-right corner of the screen and then touch *Controls*.

4. Change the incline of the treadmill as desired.

You can change the incline of the treadmill in the same way as the speed, using the Incline buttons on the console or the numbered incline buttons on the left side of the screen.

5. Follow your progress.

The console offers several display modes. Touch the workout settings icon in the lower-right corner of the screen to turn on and turn off options such as *Metrics* and *Charts*.

To adjust the volume level, touch the workout settings icon in the lower-right corner of the screen and then touch *Audio*. There may also be volume increase and decrease buttons on the console.

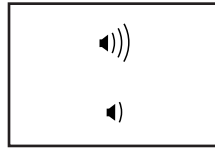

6. Pause or end the workout.

To pause the workout, first **step onto the foot rails**. Next, touch the pause symbol next to the word *Workout* at the bottom of the screen or press the Stop button on the console. To continue the workout, touch *Resume* on the screen or press the Start button on the console.

To end the workout, first **step onto the foot rails**. Next, touch the pause symbol next to the word *Workout* on the screen and then touch *End*, or press the Stop button on the console. A workout summary will appear. Touch the back arrow button in the upper-left corner of the screen to return to the home screen.

7. When you are finished using the treadmill, turn off the console (see page 17).

HOW TO USE A FEATURED WORKOUT

To use a featured workout, the console must be connected to a wireless network.

1. Select the home screen.

When you turn on the console, the home screen will appear after the console boots up. If you have already selected a workout, touch the screen and follow the prompts to end the workout and return to the home screen.

2. Select a workout.

To select a workout, slide or flick the screen to scroll vertically or horizontally to see all available workouts. You can also touch the *Search* icon on the left side of the screen and search for workouts by categories such as duration, location, trainer, and so forth. Then, touch the desired workout image on the screen.

The featured workouts on your console will change periodically. To save a featured workout for future use, add it as a favorite by touching the favorites button (heart symbol). Note: You must be logged in to your iFIT account to save a featured workout (see step 2 on page 21).

When you select a workout, the screen will show an overview of the workout with details such as the duration and distance of the workout and the estimated number of calories that you will burn during the workout.

3. Get ready for the workout.

Touch *Start workout*. The walking belt will start to move at a slow speed and a warm-up period will begin.

To use the fan, your Bluetooth headphones, or an optional heart rate monitor, see page 24.

4. Start the workout.

Walk until the warm-up period ends or touch *Skip warmup*.

During some workouts, an iFIT trainer will guide you through an immersive video workout. Touch the workout settings icon in the lower-right corner of the screen and then touch *Audio* to select music, trainer voice, and volume options for the workout.

During some workouts, the screen will show a map of the route and a marker indicating your progress. Touch the buttons on the screen to select the desired map options.

During the workout, the speed and incline of the treadmill will change automatically according to the settings of the workout. **If the speed and/or incline level is too high or too low**, you can manually override the setting (see steps 3 and 4 on page 18). To return to the programmed speed and/or incline settings of the workout, touch *Follow Trainer*.

If the SmartAdjust feature is enabled, the console will scale the intensity of the workout automatically based on your manual overrides of the speed and incline settings. **To enable the SmartAdjust feature**, touch the workout settings icon in the lower-right corner of the screen and then touch *Features*.

IMPORTANT: The calorie goal shown in the workout description is only an estimate. The actual number of calories that you burn will depend on various factors such as your weight. In addition, if you manually change the speed or incline level during the workout, the number of calories that you burn will be affected.

If the ActivePulse feature is enabled, the console will scale the intensity of the workout automatically based on your heart rate when you use a compatible heart rate monitor. **To enable the ActivePulse feature**, touch the workout settings icon in the lower-right corner of the screen and then touch *Features*.

To follow your progress, see step 5 on page 19.

To pause or end the workout, see step 6 on page 19.

5. When you are finished using the treadmill, turn off the console (see page 17).

HOW TO CREATE AND USE A CUSTOM WORKOUT

To create and use a custom workout, you must be logged in to your iFIT account and the console must be connected to a wireless network.

1. Select the home screen.

When you turn on the console, the home screen will appear after the console boots up. If you have already selected a workout, touch the screen and follow the prompts to end the workout and return to the home screen.

2. Create a custom workout.

First, touch the *Create* icon on the left side of the screen. Next, touch either *Workout builder* or *Set a goal*.

If you selected *Workout builder*, touch *Create your workout* and enter the desired time, speed, and incline settings and the desired number of sets to create an interval workout. To name the workout, touch the pencil icon next to *My Workout*. Then, touch *Save*.

If you selected *Set a goal*, enter the desired time, speed, and incline settings. To name the workout, touch the pencil icon next to *My Workout*. Then, touch *Save*.

3. Get ready for the workout.

Touch *Start Workout*. The walking belt will start to move at a slow speed and a warm-up period will begin.

To use the fan, your Bluetooth headphones, or an optional heart rate monitor, see page 24.

4. Start the workout.

Walk until the warm-up period ends or touch *Skip warmup*. The workout will function in the same way as a featured workout (see step 4 on page 20).

5. When you are finished using the treadmill, turn off the console (see page 17).

HOW TO USE AN iFIT WORKOUT

To use an iFIT workout, you must be logged in to your iFIT account and the console must be connected to a wireless network. **For more information about iFIT, go to iFIT.com.**

1. Select the home screen.

When you turn on the console, the home screen will appear after the console boots up. If you have already selected a workout, touch the screen and follow the prompts to end the workout and return to the home screen.

2. Log in to your iFIT account.

If you have not done so, touch the console settings button (gear icon) on the screen and then touch *Membership* to log in to your iFIT account. Follow the prompts on the screen to enter your username and password.

Note: To switch users within your iFIT account, select the home screen and then touch the circular icon in the lower-left corner of the screen. If more than one user is associated with the account, a list of users will appear. Touch the name of the desired user.

3. Select an iFIT workout from the home screen or the workout library.

To select an iFIT workout, slide or flick the screen to scroll vertically or horizontally to see all available workouts. You can also touch the *Search* icon on the left side of the screen and search for workouts by categories such as duration, location, trainer, and so forth. Then, touch the desired workout image on the screen.

When you select an iFIT workout, the screen will show an overview of the workout that includes details such as the duration and distance of the workout and the approximate number of calories that you will burn during the workout.

You can also select options such as adding the workout to your schedule (see step 4) or marking the workout as a favorite (see step 5).

4. Schedule an iFIT workout on the calendar if desired.

To schedule an iFIT workout for a future date, simply view the overview or workout summary of the desired iFIT workout, touch the calendar icon, and then select the desired date on the calendar. When the selected date arrives, the iFIT workout that you scheduled will appear on the home screen.

5. Create a list of favorite iFIT workouts if desired.

To mark an iFIT workout as a favorite, simply view the overview or workout summary of the desired iFIT workout and touch the favorites button (heart symbol).

To view a list of iFIT workouts that you have marked as favorites, touch the heart icon at the top of the home screen.

6. Get ready for the workout.

Touch *Start Workout*. The walking belt will start to move at a slow speed and a warm-up period will begin.

To use the fan, your Bluetooth headphones, or an optional heart rate monitor, see page 24.

7. Start the workout.

Walk until the warm-up period ends or touch *Skip warmup*. The workout will function in the same way as a featured workout (see step 4 on page 20).

8. When you are finished using the treadmill, turn off the console (see page 17).

HOW TO CHANGE CONSOLE SETTINGS

1. Select the console settings menu.

When you turn on the console, the home screen will appear after the console boots up. If you have already selected a workout, touch the screen and follow the prompts to end the workout and return to the home screen.

Then, touch the console settings button (gear icon) on the screen.

2. Navigate the console settings menu.

You may be able to view and change settings in the following settings menus:

Your account

- Account info, password
- Health details

Preferences

- Wi-Fi
- Units of measurement
- Time zone
- Language
- iFIT AI Coach

Workout

- ActivePulse
- Max speed

Equipment

- About
- Update Software
- Calibrate

Membership

- Manage membership
- Plan profiles

Support

- Report an issue
- Help
- Legal

3. Customize settings.

The console can display speed and distance in either Imperial (standard) or metric units of measurement. To change the unit of measurement or to change other settings, touch *Preferences* or *Equipment* and then touch the desired settings.

4. Update the console software.

For the best results, regularly check for software updates. Touch *Equipment* and then touch *Software update*. Software updates will begin automatically. **IMPORTANT: To avoid damaging the treadmill, do not press the power switch or unplug the power cord while the software is being updated.**

When the update is complete, the console will turn off and then turn back on. If it does not, press the power switch into the off position, wait for several seconds, and then press the power switch into the reset position. Note: Software updates are always designed to improve your workout experience. After a software update, some settings and features described in this manual may no longer apply to your console, and your console may have new settings and features.

5. Calibrate the incline system.

To calibrate the incline system, touch *Equipment*, touch *Calibrate*, and then touch *Calibrate*. The frame will rise to the maximum incline level, descend to the minimum incline level, and then return to the starting position. When the incline system is calibrated, touch *Finish*. **IMPORTANT: Keep pets, feet, and other objects away from the treadmill while the incline system is calibrating. In an emergency, remove the key from the console to stop the incline calibration.** Note: The incline system may occasionally calibrate automatically when you turn on the treadmill. Wait for the frame to stop moving before you attempt to use the treadmill.

6. Exit the console settings menu.

To exit the console settings menu, touch the X in the upper-left corner of the screen.

HOW TO CHANGE WORKOUT SETTINGS

1. Select the workout settings menu.

Touch the workout settings icon in the lower-right corner of the screen.

2. Navigate the workout settings menu and customize workout settings.

You may be able to view and change settings in the following menus:

Audio

- App volume
- Speaker volume

Fan

Bluetooth

Features

- SmartAdjust
- ActivePulse

Display

- iFIT Closed Captions
- Screen brightness

Note: Some workout controls are disabled when no workout is running.

3. Exit the workout settings menu.

To exit the workout settings menu, touch the X in the lower-right corner of the screen.

HOW TO CONNECT TO A WIRELESS NETWORK

1. Select the console settings menu.

With the home screen selected, touch the console settings button (gear icon) on the screen and then touch *Preferences*.

2. Set up and manage a wireless network connection.

Touch *Wi-Fi* to select the wireless network menu. If *Wi-Fi* is not enabled, touch the *Wi-Fi* toggle to enable it. When Wi-Fi is enabled, the screen will show a list of available networks. Note: It may take a moment for the list of wireless networks to appear.

Note: You must have your own wireless network and an 802.11b/g/n router with SSID broadcast enabled (hidden networks are not supported). The console supports unsecured and secured (WEP, WPA™, and WPA2™) encryption. A broadband connection is recommended; performance depends on connection speed.

When a list of networks appears, touch the desired network. Note: You will need to know your network name (SSID). If your network has a password, you will also need to know the password. Follow the prompts on the screen to enter your password and connect to the selected wireless network. Passwords are case-sensitive.

When the console is connected to your wireless network, a confirmation message will appear on the screen.

If you have problems connecting to an encrypted network, make sure that your password is correct. **If you have questions after following these instructions, please go to my.iFIT.com for assistance.**

3. Exit the console settings menu.

To exit the console settings menu, touch the X in the upper-left corner of the screen.

HOW TO USE THE CHARGING PORT

The console features a charging port to charge USB-C compatible devices, such as smartphones and tablets, while you exercise.

To use the charging port, plug a USB-C charging cable (not included) into the receptacle on your device and into the charging port on the right side of the console; **make sure that the USB-C charging cable is fully plugged in.** Note: The charging port cannot be used to view or transfer data or to play music through the console sound system.

HOW TO USE THE FAN

The fan has multiple speed settings, including an auto mode. While the auto mode is selected, the speed of the fan will automatically change as the speed of the walking belt changes. To control the fan, touch the workout settings icon in the lower-right corner of the screen and then touch *Fan* or press the fan buttons on the console.

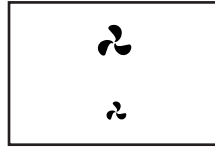

HOW TO CONNECT HEADPHONES

To connect your Bluetooth headphones to the console, first turn on your headphones, put them in pairing mode, and place them near the console. Next, start a workout. Then, touch the workout settings icon in the lower-right corner of the screen, touch *Bluetooth*, and select your headphones from the list on the screen.

When your headphones and the console pair successfully, the audio from the console will play through your headphones.

HOW TO USE AN OPTIONAL HEART RATE MONITOR

Whether your goal is to burn fat or to strengthen your cardiovascular system, the key to achieving the best results is to maintain the proper heart rate during your workouts. The optional heart rate monitor will enable you to continuously monitor your heart rate while you exercise, helping you to reach your personal fitness goals. The console is compatible with all Bluetooth® Smart heart rate monitors. **To purchase an optional heart rate monitor, please see the front cover of this manual.**

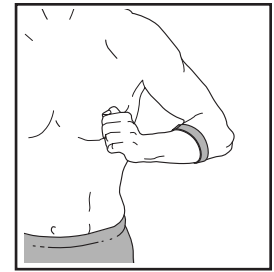

When your compatible heart rate monitor is turned on and placed in pairing mode, the console will connect to it automatically. When your heartbeat is detected, your heart rate will be shown on the screen.

HOW TO FOLD AND MOVE THE TREADMILL

HOW TO FOLD THE TREADMILL

To avoid damaging the treadmill, adjust the incline to 0% before you fold the treadmill. Then, remove the key and unplug the power cord. **CAUTION:** You must be able to safely lift 45 lbs. (20 kg) to raise, lower, or move the treadmill.

1. Hold the metal frame (A) firmly in the location shown by the arrow below. **CAUTION: Do not hold the frame by the plastic foot rails. Bend your legs and keep your back straight.**

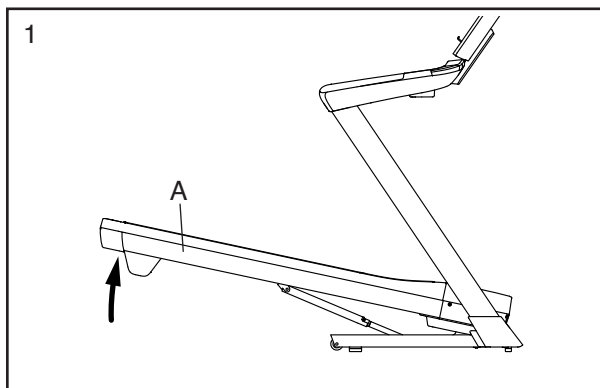

2. Raise the frame (A) until the storage latch (B) locks in the storage position. **CAUTION: Make sure that the storage latch locks.**

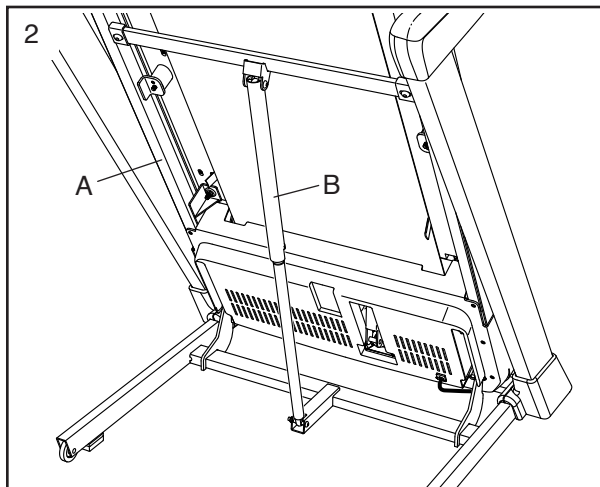

To protect the floor or carpet, place a mat under the treadmill. Keep the treadmill out of direct sunlight. Do not leave the treadmill in the storage position in temperatures above 85°F (30°C).

HOW TO MOVE THE TREADMILL

Before moving the treadmill, fold it as described at the left. **CAUTION: Make sure that the storage latch is in the locked position. Moving the treadmill requires two people. Take any necessary measures to avoid damaging your floor.**

1. Hold the frame (A) and one of the handrails (C), and place one foot against a wheel (D).

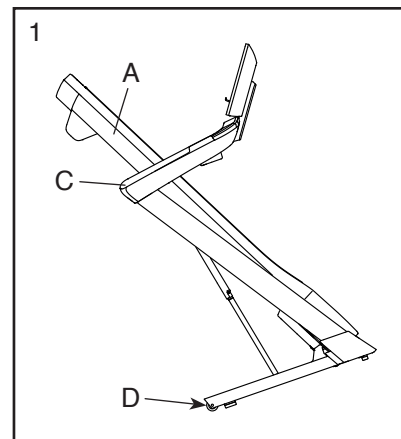

2. Pull back on the handrail (C) until the treadmill will roll on the wheels (D), and carefully move it to the desired location. **CAUTION: Do not move the treadmill without tipping it back, do not pull on the frame, and do not move the treadmill over an uneven surface.**
3. Place one foot against a wheel (D), and carefully lower the treadmill.

HOW TO LOWER THE TREADMILL FOR USE

1. Push the upper end of the frame forward, and gently press the upper part of the storage latch with your foot at the same time.
2. While pressing the storage latch with your foot, pull the upper end of the frame toward yourself.
3. Step back and let the frame descend to the floor.

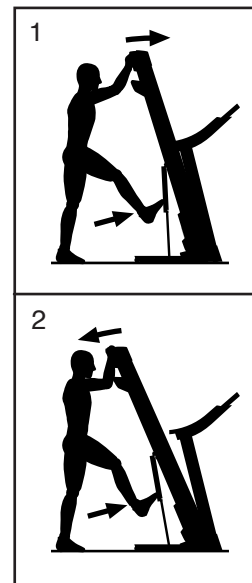

MAINTENANCE AND TROUBLESHOOTING

MAINTENANCE

Regular maintenance is important for optimal performance and to reduce wear. Inspect and properly tighten all parts each time the treadmill is used.

Replace any worn parts immediately. Use only manufacturer-supplied parts.

Regularly clean the treadmill and keep the walking belt clean and dry. First, **press the power switch into the off position and unplug the power cord.** Wipe exterior parts of the treadmill with a damp cloth and a small amount of mild soap. **IMPORTANT: Do not spray liquids directly onto the treadmill. To avoid damage to the console, keep liquids away from the console.** Then, thoroughly dry the treadmill with a soft towel.

TROUBLESHOOTING

Most treadmill problems can be solved by following the simple steps below. Find the symptom that applies, and follow the steps listed. If further assistance is needed, see the front cover of this manual.

SYMPTOM: The power does not turn on

- If an extension cord is needed, use only a 3-conductor, 14-gauge (2 mm²) cord that is no longer than 5 ft. (1.5 m).
- After the power cord has been plugged in, make sure that the key is inserted into the console.
- Check the power switch located on the treadmill frame near the power cord. If the switch protrudes as shown (A), the switch has tripped. To reset the power switch, wait for five minutes and then press the switch back in (B).

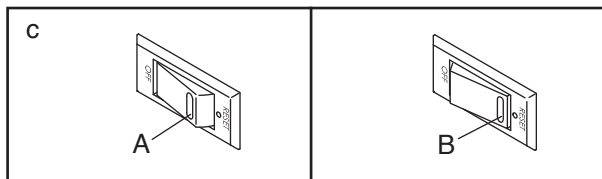

SYMPTOM: The power turns off during use

- Check the power switch (see drawing c above). If the switch has tripped, wait for five minutes and then press the switch back in.
- Make sure that the power cord is plugged in. If the power cord is plugged in, unplug it, wait for five minutes, and then plug it back in.
- Remove the key from the console, and then reinsert it.
- If the treadmill still will not run, please see the front cover of this manual.

SYMPTOM: The incline of the treadmill does not change correctly

- See step 5 on page 22 to calibrate the incline system.

SYMPTOM: The treadmill will not connect to the wireless network

- Make sure that the wireless settings on the console are correct (see page 23).
- Make sure that the settings for your wireless network are correct.
- If you still have questions, go to my.iFIT.com.

SYMPTOM: The walking belt slows when walked on

- a. If an extension cord is needed, use only a 3-conductor, 14-gauge (2 mm²) cord that is no longer than 5 ft. (1.5 m).
- b. If the walking belt is overtightened, treadmill performance may decrease and the walking belt may become damaged. Remove the key and **UNPLUG THE POWER CORD**. Using the hex key, turn both idler roller screws (C) counterclockwise, 1/4 of a turn. When the walking belt is properly tightened, you should be able to lift each edge of the walking belt 2 to 3 in. (5 to 7 cm) off the walking platform. **Be careful to keep the walking belt centered.** Then, plug in the power cord, insert the key, and walk on the treadmill for a few minutes. Repeat until the walking belt is properly tightened.

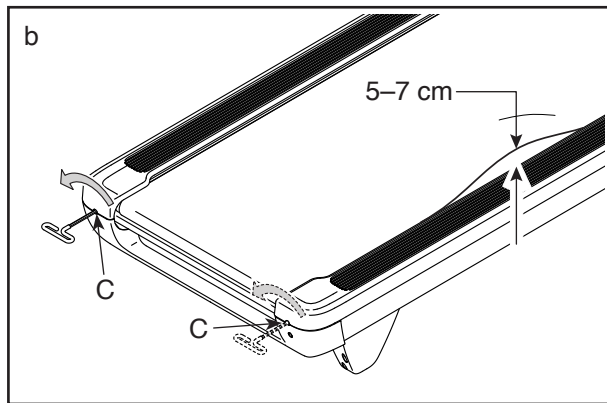

- c. Your treadmill features a walking belt coated with high-performance lubricant. **IMPORTANT: Never apply silicone spray or other substances to the walking belt or the walking platform unless instructed to do so by an authorized service representative. Such substances may deteriorate the walking belt and cause excessive wear.** If you suspect that the walking belt needs more lubricant, please see the front cover of this manual.
- d. If the walking belt still slows when walked on, please see the front cover of this manual.

SYMPTOM: The walking belt is off-center

- a. First, remove the key and **UNPLUG THE POWER CORD**. **If the walking belt has shifted to the left**, use the hex key to turn the left idler roller screw clockwise 1/2 of a turn; **if the walking belt has shifted to the right**, turn the left idler roller screw counterclockwise 1/2 of a turn. **Be careful not to overtighten the walking belt.** Then, plug in the power cord, insert the key, and walk on the treadmill for a few minutes. Repeat until the walking belt is centered.

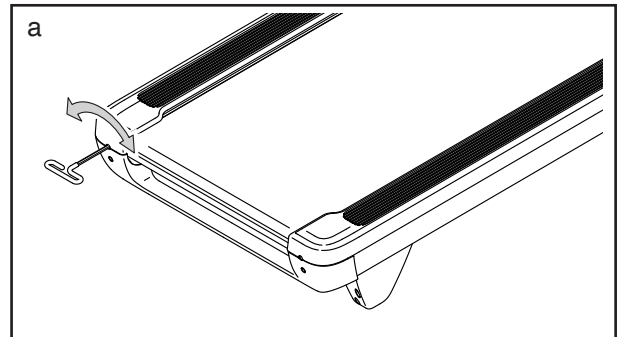

SYMPTOM: The walking belt slips when walked on

- a. First, remove the key and **UNPLUG THE POWER CORD**. Using the hex key, turn both idler roller screws clockwise, 1/4 of a turn. When the walking belt is correctly tightened, you should be able to lift each edge of the walking belt 2 to 3 in. (5 to 7 cm) off the walking platform. **Be careful to keep the walking belt centered.** Then, plug in the power cord, insert the key, and walk on the treadmill for a few minutes. Repeat until the walking belt is properly tightened.

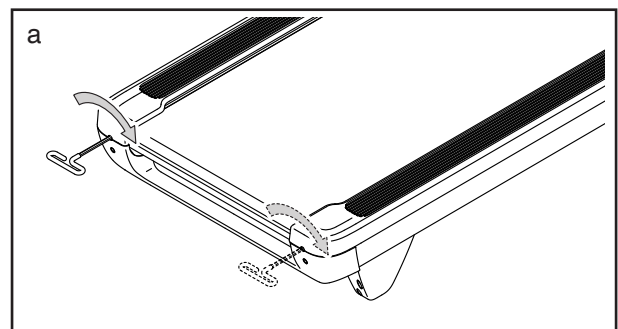

SYMPTOM: The displays of the console do not function properly

- a. If the console does not boot up properly, or if the console freezes and does not respond, reset the console to the factory default settings. **IMPORTANT: Doing this will erase all of the custom settings that you have made to the console. Resetting the console requires two people.** First, press the power switch into the off position. Next, locate the indicated small opening (D) on the left side of the console. Using a bent paper clip (E), press and hold the small button inside of the opening and have a second person press the power switch into the on/reset position. **Continue to hold the button inside of the opening until the console turns on.** When the reset operation is complete, the console will turn off and then turn back on. If it does not, use the power switch to turn the treadmill off and then on again. Once the console turns on, check for software updates (see step 4 on page 22). Note: It may take up to a few minutes for the console to be ready for use.

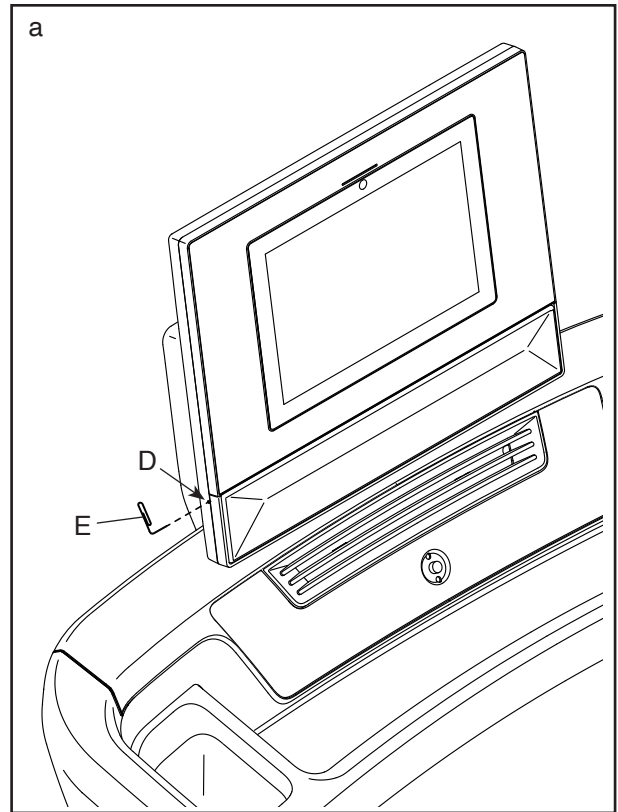

EXERCISE GUIDELINES

⚠️ WARNING: Before beginning this or any exercise program, consult your physician. This is especially important for persons over age 35 or persons with pre-existing health problems.

These guidelines will help you to plan your exercise program. For detailed exercise information, obtain a reputable book or consult your physician. Remember, proper nutrition and adequate rest are essential for successful results.

EXERCISE INTENSITY

Whether your goal is to burn fat or to strengthen your cardiovascular system, exercising at the proper intensity is the key to achieving results. You can use your heart rate as a guide to find the proper intensity level. The chart below shows recommended heart rates for fat burning and aerobic exercise.

165	155	145	140	130	125	115	♥️
145	138	130	125	118	110	103	♥️
125	120	115	110	105	95	90	♥️
<hr/>							
20	30	40	50	60	70	80	

To find the proper intensity level, find your age at the bottom of the chart (ages are rounded off to the nearest ten years). The three numbers listed above your age define your “training zone.” The lowest number is the heart rate for fat burning, the middle number is the heart rate for maximum fat burning, and the highest number is the heart rate for aerobic exercise.

Burning Fat—To burn fat effectively, you must exercise at a low intensity level for a sustained period of time. During the first few minutes of exercise, your body uses carbohydrate calories for energy. Only after the first few minutes of exercise does your body begin to use stored fat calories for energy. If your goal is to burn fat, adjust the intensity of your exercise until your heart rate is near the lowest number in your training zone. For maximum fat burning, exercise with your heart rate near the middle number in your training zone.

Aerobic Exercise—If your goal is to strengthen your cardiovascular system, you must perform aerobic exercise, which is activity that requires large amounts of oxygen for prolonged periods of time. For aerobic exercise, adjust the intensity of your exercise until your heart rate is near the highest number in your training zone.

HOW TO MEASURE YOUR HEART RATE

To measure your heart rate, exercise for at least four minutes. Then, stop exercising and place two fingers on your wrist as shown. Take a six-second heartbeat count, and multiply the result by 10 to find your heart rate. For example, if your six-second heartbeat count is 14, your heart rate is 140 beats per minute.

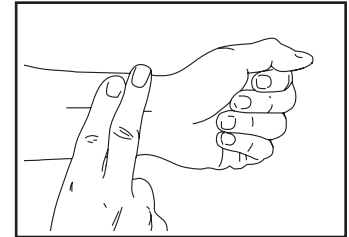

WORKOUT GUIDELINES

Warming Up—Start with 5 to 10 minutes of stretching and light exercise. A warm-up increases your body temperature, heart rate, and circulation in preparation for exercise.

Training Zone Exercise—Exercise for 20 to 30 minutes with your heart rate in your training zone. (During the first few weeks of your exercise program, do not keep your heart rate in your training zone for longer than 20 minutes.) Breathe regularly and deeply as you exercise; never hold your breath.

Cooling Down—Finish with 5 to 10 minutes of stretching. Stretching increases the flexibility of your muscles and helps to prevent post-exercise problems.

EXERCISE FREQUENCY

To maintain or improve your condition, complete three workouts each week, with at least one day of rest between workouts. After a few months of regular exercise, you may complete up to five workouts each week, if desired. Remember, the key to success is to make exercise a regular and enjoyable part of your everyday life.

PART LIST

Model No. NTL15425-INT.3 R1024A

Key No.	Qty.	Description	Key No.	Qty.	Description
1	4	3/8" x 2 1/2" Screw	51	1	Controller Plate
2	4	3/8" x 3/4" Screw	52	3	Wire Tie
3	1	Ground Screw	53	1	Latch Crossbar
4	4	5/16" x 1 1/4" Screw	54	1	Drive Motor
5	5	M4 x 10mm Screw	55	1	Motor Belt
6	12	3/8" Star Washer	56	1	Storage Latch
7	4	5/16" Star Washer	57	1	Frame
8	2	5/16" x 3/4" Screw	58	2	Rear Foot
9	2	3/8" x 1 3/8" Bolt	59	1	Right Rear Endcap
10	3	1/4" x 2 1/2" Screw	60	1	Left Rear Endcap
11	2	3/8" x 1 1/8" Screw	61	1	Idler Roller
12	48	#8 x 3/4" Screw	62	1	Motor Hood
13	2	1/4" x 1 1/4" Screw	63	2	Incline Frame Spacer
14	39	#8 x 3/4" Washer Head Screw	64	4	3/8" Plastic Bushing
15	12	#8 x 5/8" Screw	65	2	Frame Spacer
16	1	3/8" x 2 1/4" Bolt	66	1	Incline Frame
17	1	3/8" x 1 1/2" Bolt	67	1	Incline Motor
18	2	5/16" Motor Screw	68	2	Incline Motor Spacer
19	1	Saddle Bracket Cover	69	1	Controller
20	4	#8 Belt Guide Screw	70	1	Power Cord
21	4	5/16" x 1 3/4" Shoulder Bolt	71	1	Power Cord Grommet
22	1	5/16" x 1 3/4" Bolt	72	1	Power Switch
23	1	5/16" x 2 1/4" Bolt	73	1	Belly Pan
24	10	#8 x 1/2" Washer Head Screw	74	1	Left Handrail Cover
25	4	#4 x 1/4" Screw	75	1	Right Handrail Cover
26	6	Mushroom Fastener	76	1	Left Handrail Outer Cover
27	2	#8 Star Washer	77	1	Right Handrail Outer Cover
28	4	5/16" Flat Washer	78	1	Left Handrail Inner Cover
29	4	3/8" Thrust Washer	79	1	Right Handrail Inner Cover
30	12	Small Flat Washer	80	1	Tray
31	13	1/4" Nut	81	1	Handrail Frame
32	5	Hood Clip	82	1	Upright Wire
33	4	3/8" Nut	83	1	Handrail Wire
34	6	5/16" Nut	84	1	Left Upright
35	4	#3 x 3/16" Screw	85	1	Right Upright
36	2	#8 x 3/4" Truss Head Screw	86	1	Grommet
37	6	Large Cushion	87	1	Circuit Board
38	1	Rear Cover	88	4	Base Pad
39	4	M6 x 16mm Pan Head Screw	89	1	Right Base Cover
40	4	M6 x 25mm Screw	90	1	Left Base Cover
41	1	Walking Platform	91	1	Right Inner Base Cover
42	1	Walking Belt	92	1	Left Inner Base Cover
43	2	Belt Guide	93	1	Lower Display Cover
44	1	Left Foot Rail	94	1	Base
45	1	Right Foot Rail	95	1	Display
46	1	Drive Roller/Pulley	96	1	Upper Display Cover
47	4	Small Cushion	97	1	Display Frame
48	2	9/32" Plastic Bushing	98	2	Ground Wire
49	2	1/2" Pin	99	1	Key/Clip
50	1	Circuit Board Cover	100	2	Mounting Spacer

Key No.	Qty.	Description	Key No.	Qty.	Description
101	1	Small Pivot Cover	114	1	Large Saddle Bracket
102	1	Large Pivot Cover	115	4	3/8" x 3 1/4" Screw
103	1	Primary Control	116	–	(Not Used)
104	1	Fan Grill	117	1	Small Saddle Bracket
105	2	Cable Tie	118	4	#8 x 1/2" Screw
106	1	Primary Control Base	119	2	Motor Bushing
107	1	Display Back Plate	120	1	Motor Isolator
108	4	5/16" Bushing	121	2	#8 Nut
109	1	U-bracket	122	1	Filter
110	2	Wheel	123	2	#8 x 1/2" Bolt
111	2	3/8" Distorted Nut	124	2	3/8" Thrust Washer
112	1	Fan	*	–	Assembly/Adjustment Tool Kit
113	1	Circuit Board Plate	*	–	User's Manual

Note: Specifications are subject to change without notice. For information about ordering replacement parts, see the back cover of this manual. *These parts are not illustrated.

EXPLODED DRAWING A

Model No. NTL15425-INT.3 R1024A

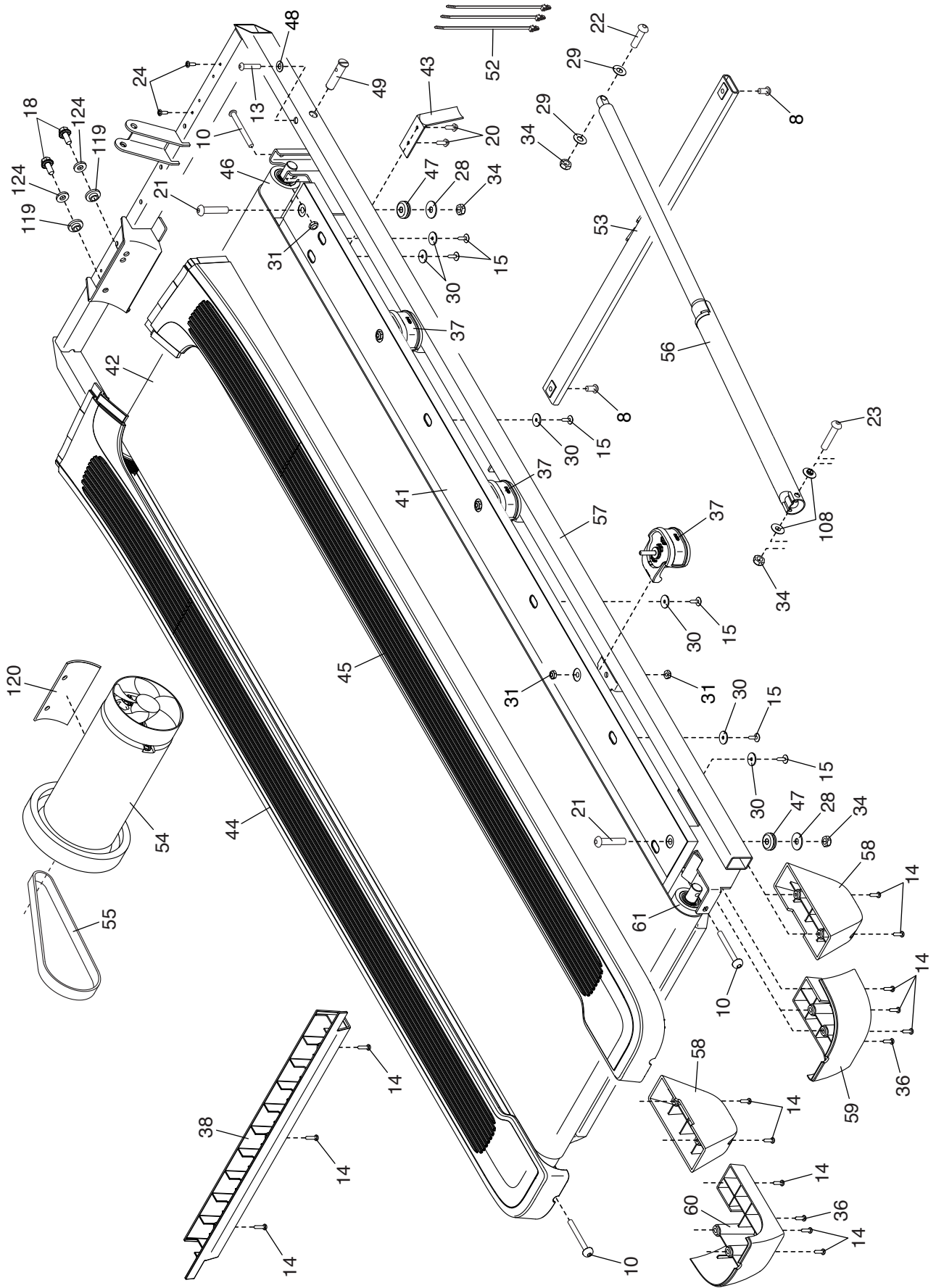

EXPLODED DRAWING B

Model No. NTL15425-INT.3 R1024A

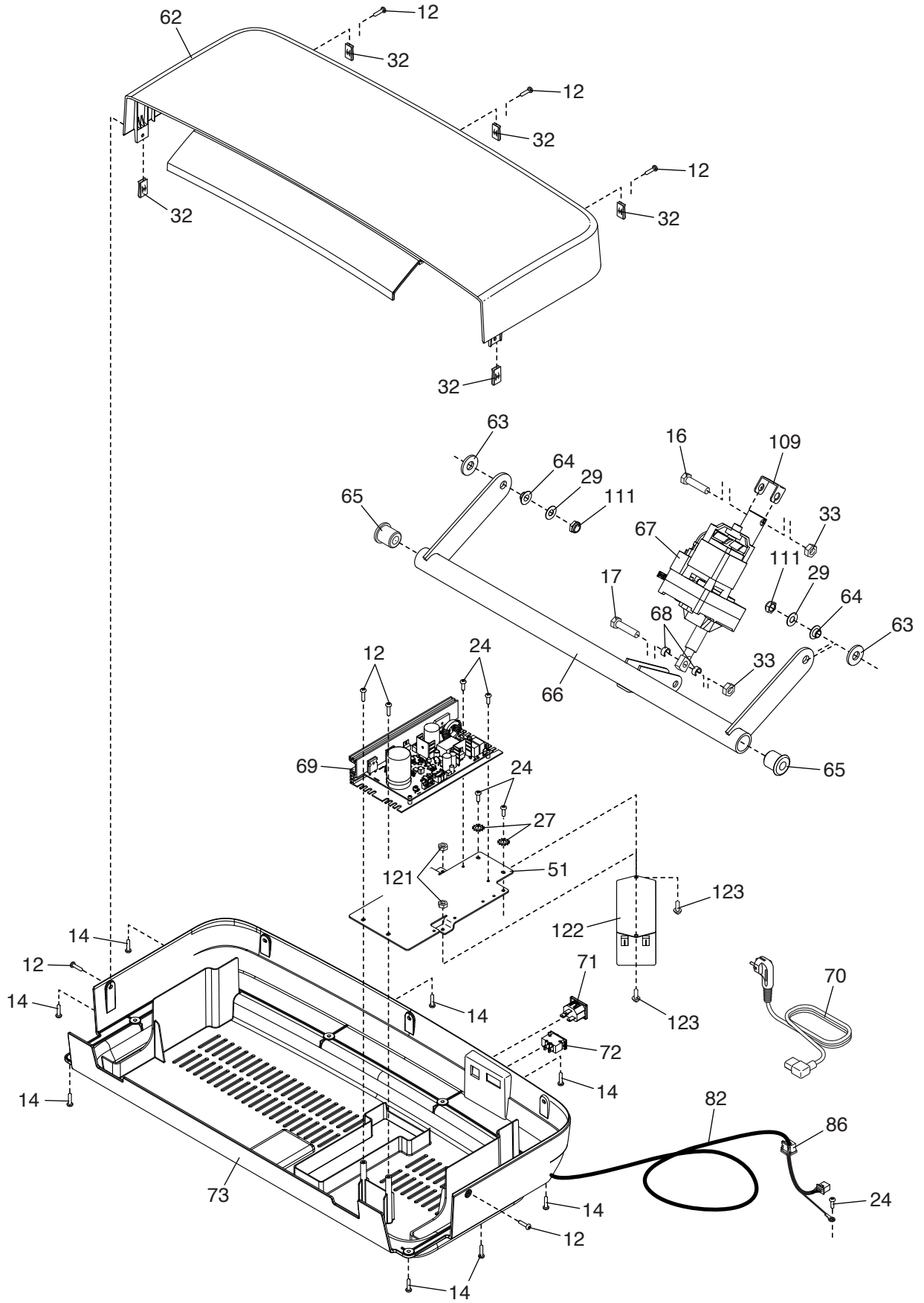

EXPLODED DRAWING C

Model No. NTL15425-INT.3 R1024A

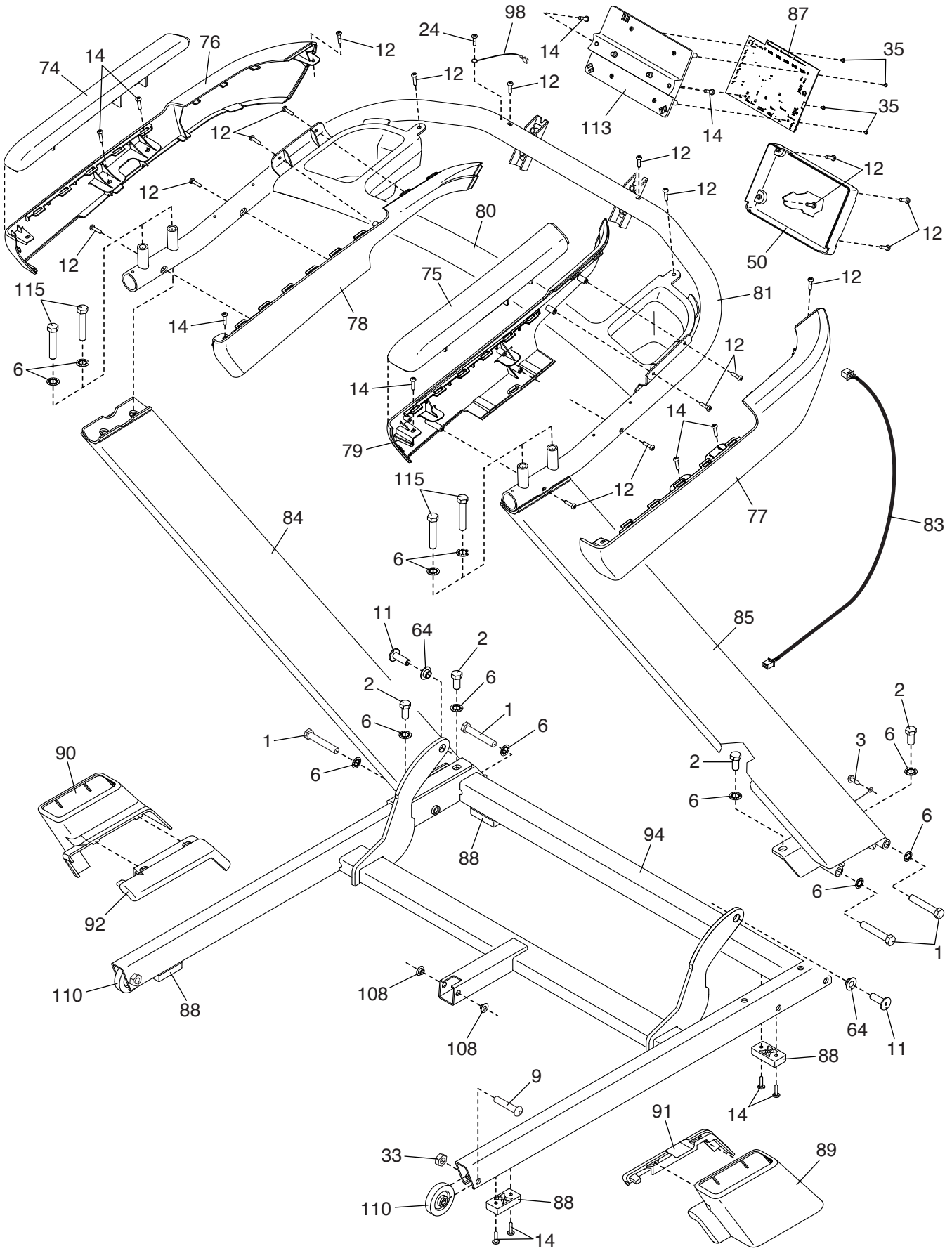

EXPLODED DRAWING D

Model No. NTL15425-INT.3 R1024A

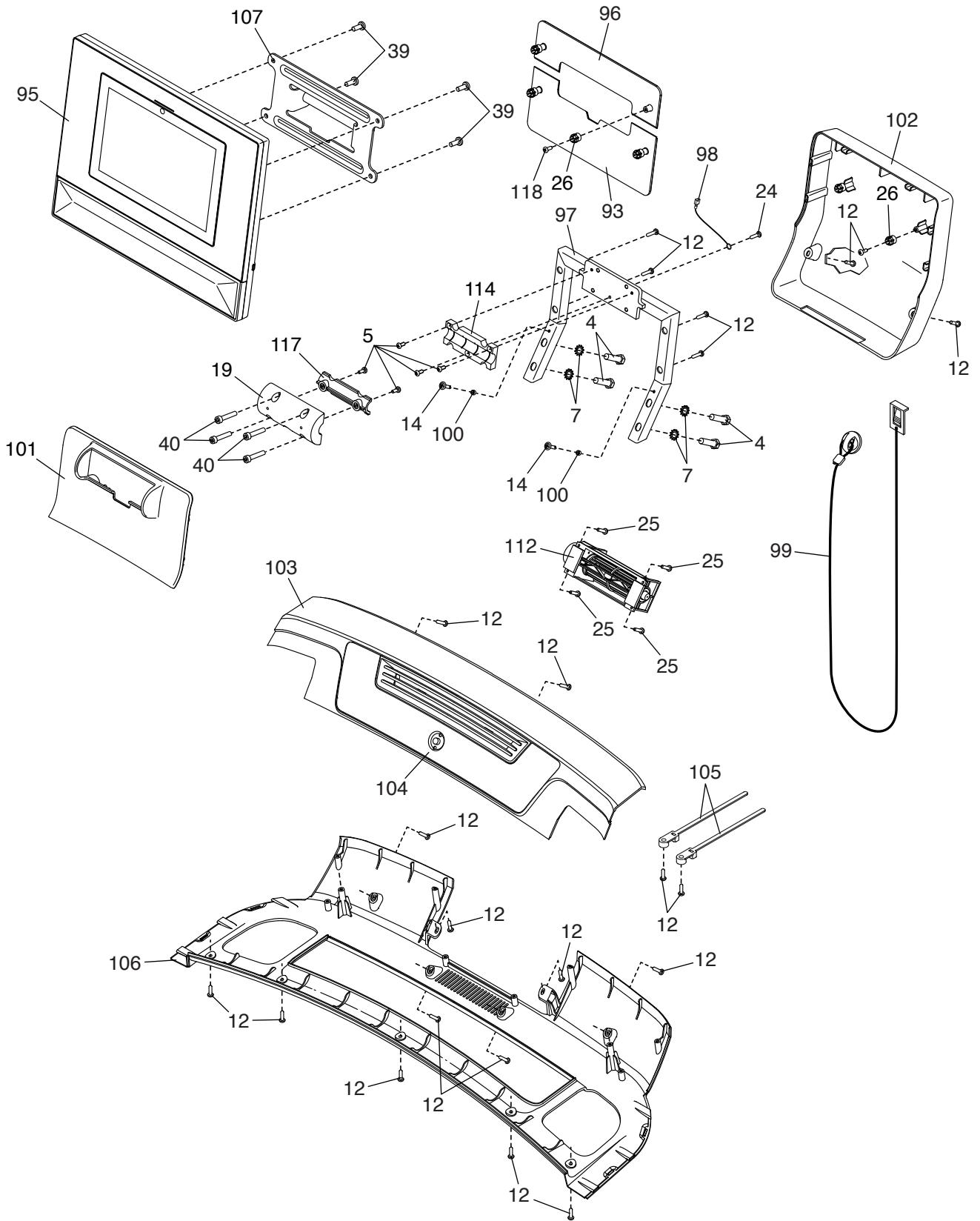

ORDERING REPLACEMENT PARTS

To order replacement parts, please see the front cover of this manual. To help us assist you, be prepared to provide the following information when contacting us:

- the model number and serial number of the product (see the front cover of this manual)
- the name of the product (see the front cover of this manual)
- the key number and description of the replacement part(s) (see the PART LIST and the EXPLODED DRAWING near the end of this manual)

RECYCLING INFORMATION

This electronic product must not be disposed of in municipal waste. To preserve the environment, this product must be recycled after its useful life as required by law.

Please use recycling facilities that are authorized to collect this type of waste in your area. In doing so, you will help to conserve natural resources and improve European standards of environmental protection. If you require more information about safe and correct disposal methods, please contact your local city office or the establishment where you purchased this product.

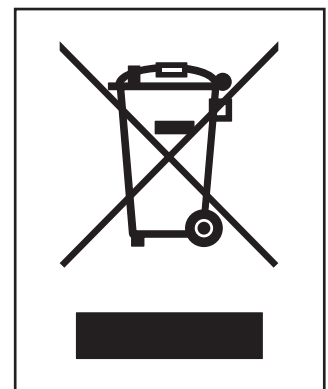

UK/EU DECLARATION OF CONFORMITY

NTL15425-INT contains the MP10-Xenon-C or MP10-Xenon-V Tablet.

Hereby, iFIT Health & Fitness declares that the radio equipment type MP10-Xenon-C or MP10-Xenon-V is in compliance with Directive 2014/53/EU and Radio Equipment Regulation 2017.

iFIT Health & Fitness, 1500 S 1000 W, Logan, UT 84320, USA

This declaration of conformity is issued under the sole responsibility of the manufacturer.

Object of the declaration: FCCID OMC453584C or OMC453584V - Broadcast Frequency Bands and Maximum EIRP power: 2.4GHz

WiFi:25.02dBm; 5GHz WiFi:22.89dBm; BT 2.4GHz:10.12dBm.

Operations in the 5.15-5.35GHz band are restricted to indoor usage only in following Countries:

Certification: Article 3.1a - Safety EN 62479:2010, EN 62368-1:2014/AC:2015,

Article 3.1b – EMC EN 301 489-1, 2.2.3, EN 301 489-17 V3.2.4, Article 3.2 –

Radio parameters EN 300 328 V2.2.2, EN 301 893 V2.1.1

UK Representative: ICON Health & Fitness Ltd, Unit 1D The Gateway,

Fryers Way, Silkwood Park, Ossett, WF5 9TJ, United Kingdom

EU Representative: iFIT Health & Fitness SAS Business Park, 5 rue Alfred de Vigny, 78112 Fourqueux, France

	BE	BG	CZ	DK	DE	EE	IE
	EL	ES	FR	HR	IT	CY	LV
	LT	LU	HU	MT	NL	AT	PL
	PT	RO	SI	SK	FI	SE	UK

