

NOBLE·PRO

ELITE E8i

USER'S MANUAL

noble-pro.com

Treadmill Base

Model No: NPE78846E8b

Serial No:

Locate the serial number on the front of the treadmill base.

Treadmill Screen

Model No: NPE78853E8is7

Serial No:

Locate the serial number on the back of the treadmill screen.

CUSTOMER CARE

**For technical support,
please visit:**

noble-pro.com/help

CAUTION

Read all precautions and instructions in this manual before using this equipment. Save this manual for future reference.

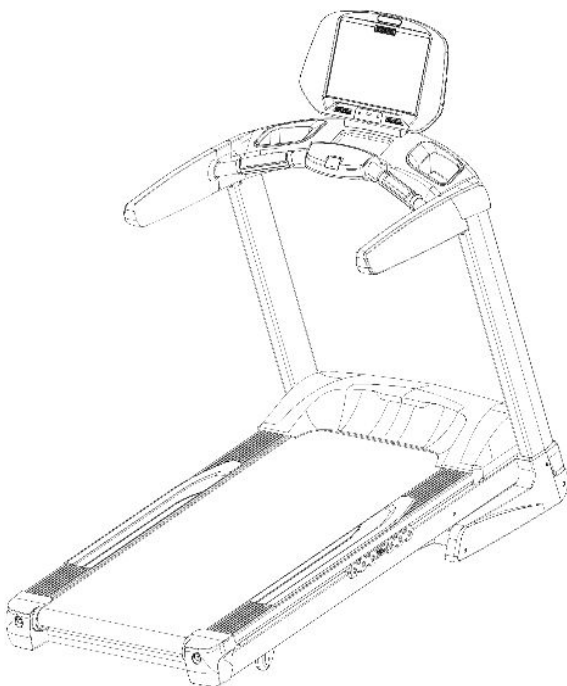

TABLE OF CONTENTS

ABOUT THE PRODUCT	5
ASSEMBLY	7
HOW TO USE THE TREADMILL	11
HOW TO FOLD AND MOVE THE TREADMILL	15
MAINTENANCE	16
TROUBLESHOOTING	18
EXPLODED DRAWING 1	19
EXPLODED DRAWING 2	21
PARTS LIST	22
ORDERING REPLACEMENT PARTS	24
WARRANTY	24

WARNING LABELS

CAUTION

Avoid Injury. Read User's Manual Before Use And:

- Stand on the side rails before you start or stop treadmill.
- Adjust speed in small increments.
- Hold handrails to avoid slipping and wear safety key before use.
- Causes use of feeling dizzy, have chest pains or shortness of breath.
- Ensure storage latch is locked before moving or storing.
- Incline to be returned to lowest level before folding or moving.

• Keep children away from this equipment.

• Remove safety key when not in use.

• Keep clothes, hair, fingers away from running belt.

• When the belt is running, do not adjust or assemble treadmill.

• Use correct shoes when using treadmill.

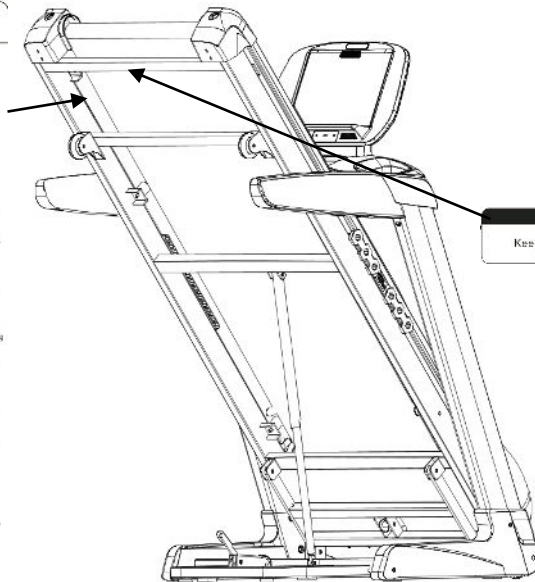

CAUTION
Keep clear under running deck when folded.

IMPORTANT PRECAUTIONS

WARNING: To reduce the risk of burns, fire, electric shock, or injury to persons, read all these **IMPORTANT** precautions and instructions in this manual and all warnings on your treadmill before using the treadmill. NoblePro Ltd assumes no responsibility for personal injury or property damage sustained by or using this product.

1. It is the owner's responsibility to ensure that all users of this treadmill are accurately informed of all warnings and precautions.
2. Before beginning any exercise program, consult your physician. This is **IMPORTANT** for persons over age 35 or persons with pre-existing health conditions.
3. Use the treadmill only as prescribed in this manual.
4. The treadmill is intended for home-use only. Do not use the treadmill in any commercial, rental or institutional setting.
5. Keep the treadmill in a secure, dry, well-ventilated area (above 5 °C) away from moisture and dust. Do not put the treadmill outside, under a covered patio or near water.
6. Place the treadmill on a level surface, with at least 8 ft. (2.4 m) of clearance behind it and 2 ft. (0.6 m) on either side. Do not place the treadmill on any surface that blocks air openings. To protect the floor or carpet from damage, place a mat under the treadmill.
7. Always keep pets and children under age 12 away from the treadmill.
8. The treadmill should be used only by persons weighing 297 lbs (135 kg) or less.
9. Never allow more than one person on the treadmill at a time.
10. Wear appropriate activewear and trainers while using the treadmill. Be aware that loose clothing could become caught on the treadmill. Never use the treadmill with bare feet, only socks or sandals.
11. Keep fingers, hair and clothing away from the moving walking belt.
12. Do not operate the treadmill where aerosol products are used or where oxygen is being administered.
13. Plug the power cord into a surge suppressor (not included), and plug the surge suppressor into an appropriate outlet. To avoid overloading the circuit, do not plug other electrical devices into the surge suppressor or an outlet on the same circuit (low-power devices such as phone chargers will not cause an issue).
14. Use only a surge suppressor / circuit breaker that meets all the specifications in this manual. Failure to use a properly functioning surge suppressor could result in damage to the control system of the treadmill. If the control system is damaged, the walking belt may slow, accelerate, or stop unexpectedly, resulting in a fall and severe injury.
15. Keep the power cord and the surge suppressor away from heated surfaces.
16. Never try to move the walking belt while the power is turned off. Do not operate the treadmill if the power cord or plug is damaged or if the treadmill is not working properly. (See MAINTENANCE AND TROUBLESHOOTING if there are issues with the treadmill.)
17. Read, understand, and test the emergency stop procedure before using the treadmill (see HOW TO TURN ON THE POWER). Always wear the safety clip while using the treadmill.
18. Always stand on the side rails when starting or stopping the walking belt. Always hold the handrails while using the treadmill
Note: When a person is walking on the treadmill, the treadmill's noise level will increase.
19. To avoid static shock, wear natural fabrics. If there is a build-up of static, check that the plug and electric are earthed correctly.
20. The treadmill is capable of high speeds. Adjust the speed in small increments to avoid sudden surges in speed.
21. The heart rate monitor is NOT a medical device. Various factors, including the user's movement, may affect the accuracy of heart rate readings. The heart rate monitor is intended only as an exercise aid in determining general heart rate trends.
22. Never leave the treadmill unattended while it is running. Always remove the safety key, press the red power switch into the off position, and unplug the power cord when the treadmill is not in use.
23. Do not attempt to move the treadmill until it is fully assembled. (See ASSEMBLY and HOW TO FOLD AND MOVE THE TREADMILL.) You must be able to safely lift 45 lbs. (20 kg) to raise, lower, or move the treadmill.

24. When folding or moving the treadmill, make sure that the storage latch is holding the frame securely in the storage position

25. Do not insert any objects into any openings on the treadmill.

26. Inspect and properly tighten all parts of the treadmill regularly.

27. Over-exercising may result in serious injury or death. If you feel faint if you become short of breath or experience pain while exercising, please stop immediately.

28. **DANGER:** Always unplug the power cord immediately after use, before cleaning the treadmill and before performing the maintenance and adjustment procedures described in this manual. Never remove the motor cover unless instructed to do so by an authorized NoblePro Ltd representative. Additional servicing, other than the procedures in this manual, should be performed by an authorized service representative only.

ABOUT THE PRODUCT

Thank you for selecting the revolutionary NoblePro® E8i treadmill. The NoblePro® E8i treadmill offers an impressive selection of features designed to make your workouts at home more effective and enjoyable. When not exercising, the treadmill can be folded up to save space.

For your benefit, read this manual carefully before using the treadmill. If you have questions after reading this manual, please see the front cover of this manual. To help us assist you, please make a note of the product model number(s) before contacting us. Before reading further, please review the drawing below and familiarize yourself with the labelled parts.

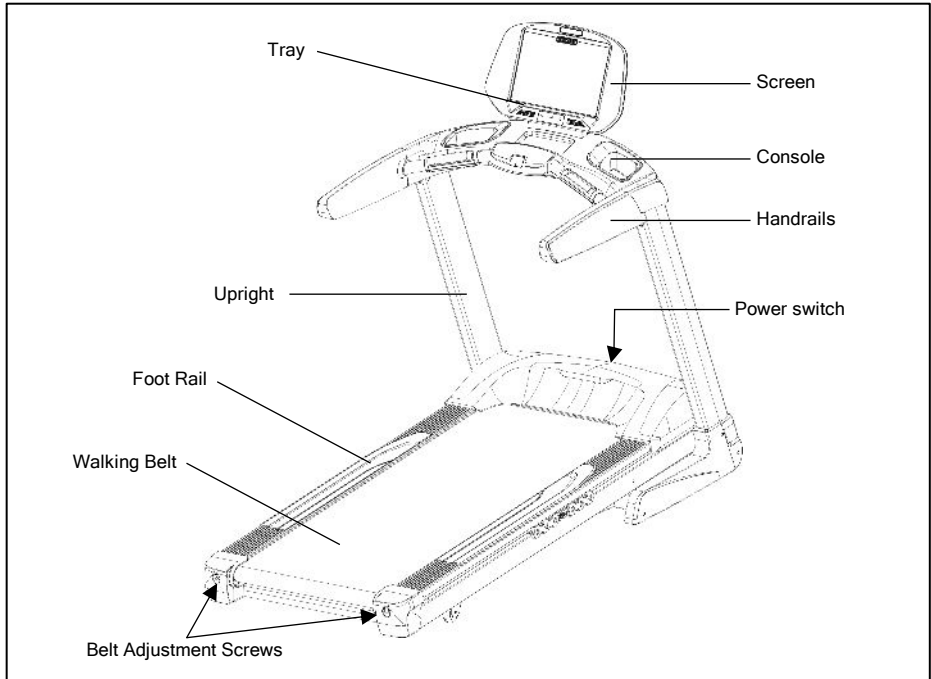

Max User Weight	135 kg
Dimensions (LxWxH)	Folded: 130 x 86 x 153cm
	Unfolded: 188 x 86 x 143cm
Running Area	150 x 52cm / 59" x 20.5
Speed Range	1.0-22km/h
Incline levels	0-20
Machine Weight	N.W.: 105kg / G.W. 115kg

Box content

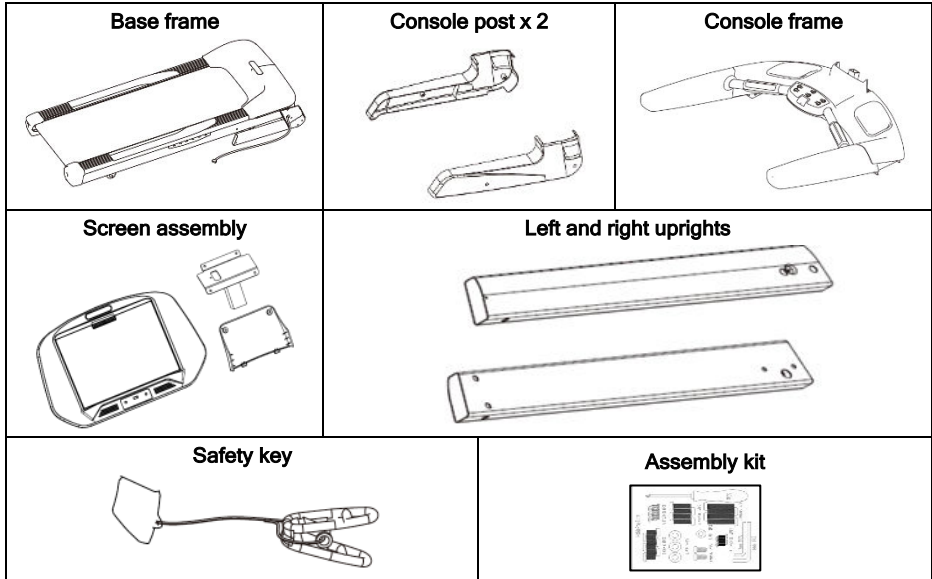

Assembly kit

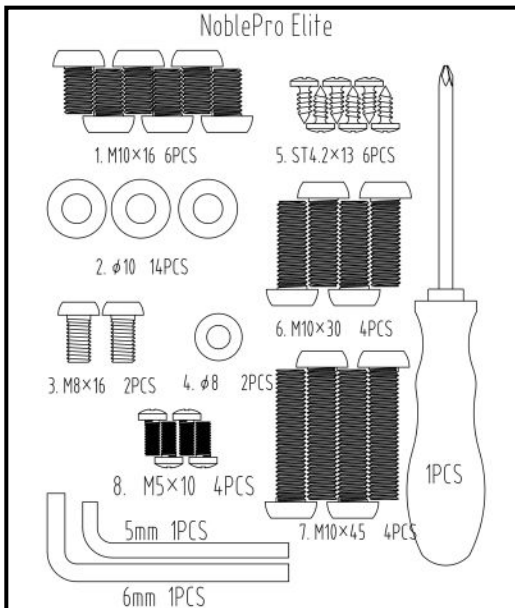

Description	QTY
1 M10*16 Screws	6
2 $\phi 10$ Washers	14
3 M8*16	2
4 $\phi 8$ Washers	2
5 ST 4.2*13	6
6 M10*30	4
7 M10*45	4
8 M5*10	4
5mm Allen Key	1
6mm Allen Key	1
Star Screwdriver	1

ASSEMBLY

ATTENTION

- Assembly requires two persons
- Assemble in a clean and level area
- Before assembly, take parts out but do not dispose of any material until complete
- Avoid using power tools
- Left parts are marked as "L". The right parts are marked as "R."
- The treadmill might be covered by light oil to preserve it from rusting

1. Register your product. Go to noble-pro.com/product-registration
2. Download the latest User's Manual from noble-pro.com/support

Note: If you are unable to register online, please submit a technical ticket with NoblePro technical support for assistance at noble-pro.com/technical-support-request/

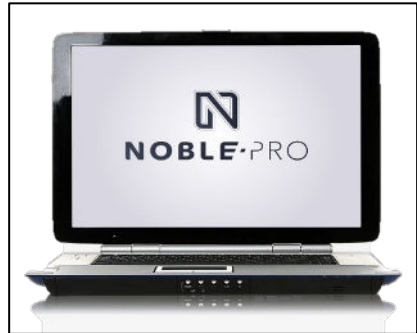

3. Identify the signal wire (163) located in the base frame (93). Feed the wire through the base frame hole as indicated (1)

Next, identify the right upright post (161). Have a second person hold the right upright post close to the base frame. (2)

Then, insert the signal wire into the right upright post while pulling the upper end of the wire tie. (3)

Place the right upright post into the base frame. **Make sure not to pinch any wires.**

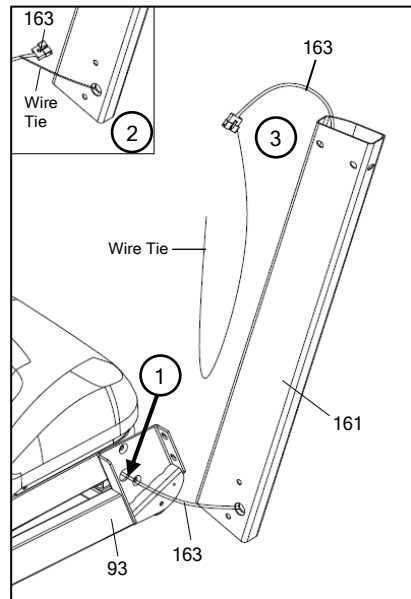

4. Loosely fasten the right upright post by using 2 x M10*45 (164) and 2 x M10*30 (167) screws with a flat washer (166) to the base frame.

Place the left upright post into the base frame. Then loosely fasten the post using 2 x M10*45 (164) and 2 x M10*30 (167) screws with a flat washer (166) to the base frame.

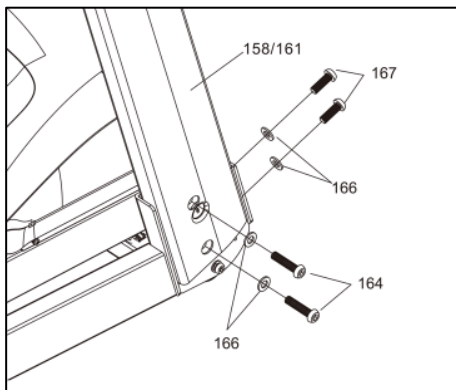

5. Locate the console signal wire (C) at the back of the Console on the right side of the console frame. Connect the signal wire (C) to the communication wire (163). Place the console frame over the uprights.

Note: Be careful not to crush the wire; it should be clear of edges.

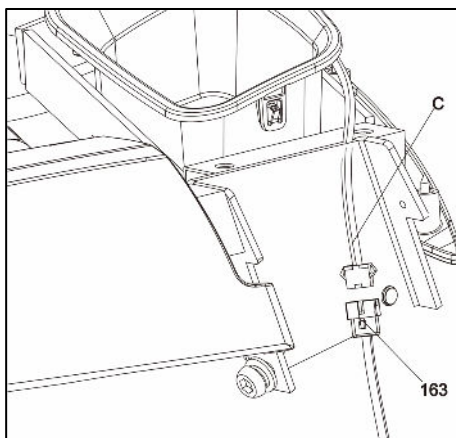

6. Use 6 x M10*16 (187) screws with a flat washer (189) to fasten the uprights to the Console. Lightly fasten all screws until all screws have been aligned. Then tighten all screws in step 4 and 6.

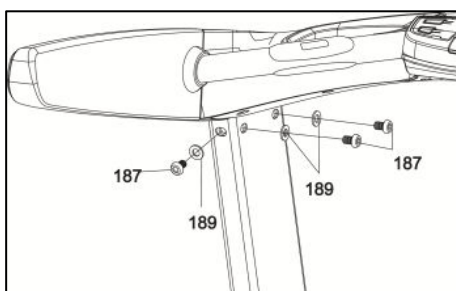

7. Feed the screen connection wires (A, B and C) through the hole in the mounting bracket (1).

Use 4 x M5*10 (8) screws to fasten the screen to the mounting bracket.

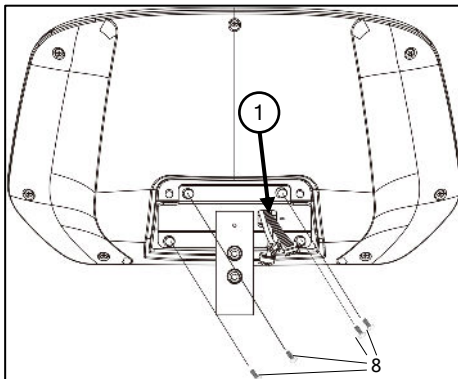

8. Place the console screen assembly on the console base. Connect the console connections A to A, B to B and C to C, respectively.

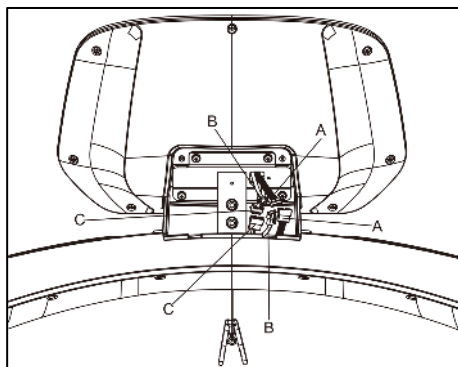

9. Use 2 x M8*16 (182) screws with flat washers (183) to fasten the console screen assembly to the console base.

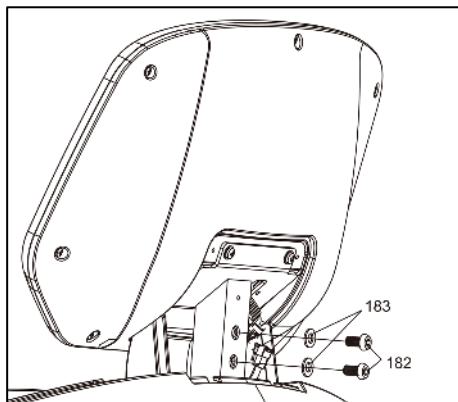

10. Use 2 x ST 4.2*13 (234) screws to fasten the screen cover panel to the back of the screen.

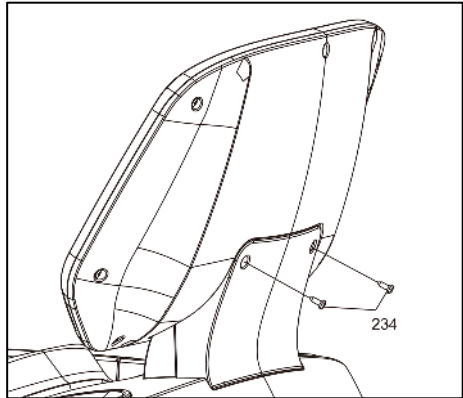

11. Place the base frame covers (123/124) in place.

Use the 4 x ST 4.2*13 (125) screws to fasten the covers to the base frame.

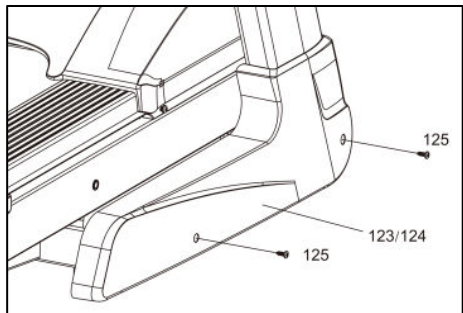

12. Remove the lock plate securing the base frame in the down position.

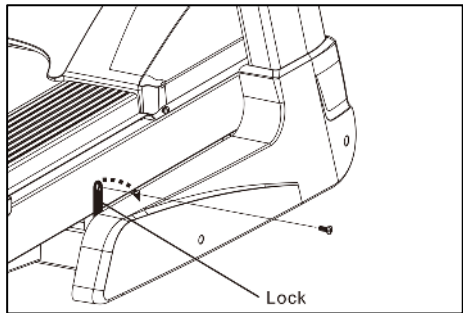

13. It is imperative to ensure that all parts are tightened before using the treadmill. It is advisable to place a protective mat under the treadmill and not onto a slippery, uneven surface.

Information: The tools provided can also be used for maintenance of the treadmill

HOW TO USE THE TREADMILL

CONNECTING THE POWER CORD

Use a Surge Suppressor

The treadmill can be damaged by sudden voltage changes in your home's power. Voltage surges, spikes, and noise interference can result from weather conditions or other appliances being turned on or off. To decrease the risk of damaging the treadmill, use a surge suppressor that complies with or exceeds UL 1449 or BS 1363 requirements. The surge suppressor must be electrically rated for 240 volts AC and a minimum of 13 amps.

Failure to use a properly functioning surge suppressor could result in damage to the control system of the treadmill and serious injury to users.

Plug in the power cord

The treadmill must be grounded. If it should malfunction or break down, grounding provides a path of least resistance for an electric current to reduce the risk of electric shock. Plug the power cord into a surge suppressor and plug the surge suppressor into an appropriate outlet that is properly installed and grounded in accordance with all local rules and regulations. The outlet must be on a nominal 240-volt circuit capable of carrying 16 or more amps. To avoid overloading the circuit, do not plug other electrical devices, except for low power devices such as cell phone chargers, into the surge suppressor or an outlet on the same circuit.

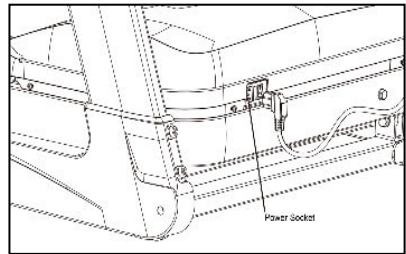

HOW TO TURN ON THE POWER

IMPORTANT: If the treadmill has been exposed to cold temperatures, allow it to warm to room temperature before turning on the power. If you do not do this, you may damage the console displays or other electrical components.

Plug in the power cord. Next, locate the power switch on the treadmill frame near the power cord. Press the power switch into the "on" position.

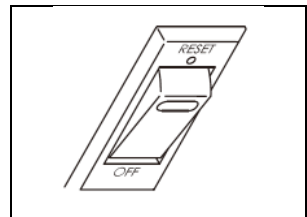

HOW TO USE THE SAFETY KEY

The safety key is designed to bring the treadmill to a stop if disconnected. Insert the key into the Console as indicated, and securely attach the clip to your clothing.

IMPORTANT: The treadmill will not function without the safety key being placed in the console.

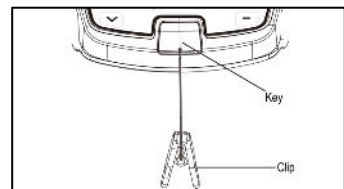

HOW TO USE THE CONSOLE

IMPORTANT Always keep your treadmill's software up to date. The latest user manual is available noble-pro.com/support

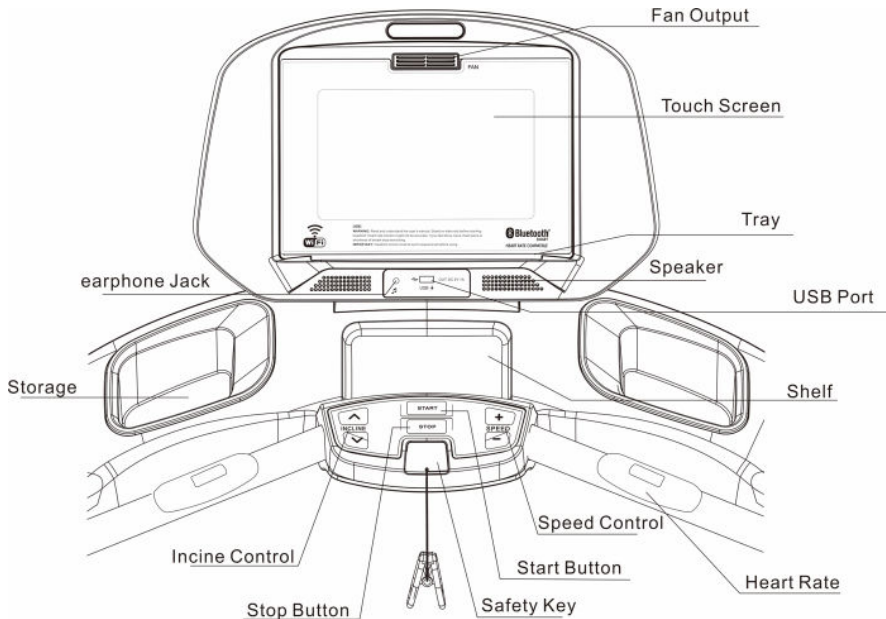

HOW TO SET UP YOUR TREADMILL

The treadmill console will require setting up before use. Follow the below instructions:

1. Connect the treadmill to Wi-Fi

The treadmill needs to be connected to Wi-Fi with internet access to ensure your software is up to date. To connect the treadmill to Wi-Fi, see page [13](#).

2. Update software

Once the treadmill is connected to the internet, it will download and update the treadmill to the newest software version. The software version will be checked every time the treadmill is turned on and goes into sleep mode.

3. Kinni App

To save workout history from your treadmill and have access to the latest features, use the Kinni mobile app or visit <https://kinni.co>



CONNECTING TO WIFI

The following steps will guide you through how to connect your treadmill to Wi-Fi.

1. On the home page, touch the Wi-Fi image.



2. Ensure the Wi-Fi is enabled

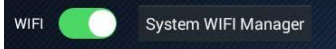

3. Select the Wi-Fi network from the available network list.
4. Enter the network password correctly.
5. Verify that the network is connected.

IMPORTANT: The Wi-Fi connection should now be established. Note: This treadmill is only compatible with the 802.11b/n router with SSID broadcast enabled.

CONNECTING TO BLUETOOTH

To find out more about Bluetooth capabilities, go to noble-pro.com/bluetooth/

HOW TO NAVIGATE USING THE TOUCH SCREEN

The main touch screen navigation controls are built into the top bar for ease of use. The key functions have been explained below:



Back button

It takes you to the previous screen



Home button

It takes you back to the home screen

There are a number of "floating" controls that enable additional functionality when using entertainment or web browsing apps. The key functions have been explained below:



Menu hider

Hides all the menus to enable the use of the full screen



Start

Enables starting of the treadmill whilst using other apps

FAN CONTROL

The single-speed fan can be turned on/off using the fan control function located in the top bar menu. We recommend the purchasing of a larger external fan if you are finding the room you are in is becoming too warm during exercise.



VOLUME CONTROL

The speaker output volume can be adjusted by using the volume management function located in the top bar menu.



DATE AND TIME SETTINGS

The time, date and automatic detection settings of time and date can be changed by touching the time in the top bar menu.



USING THE TREADMILL HANDGRIP HEART RATE MONITOR

The treadmill has built in handgrip heart rate monitors so please ensure to remove the protective plastic from the handgrips before use. For the most accurate heart rate reading, hold onto the handrails and avoid movement for 15 seconds or more.

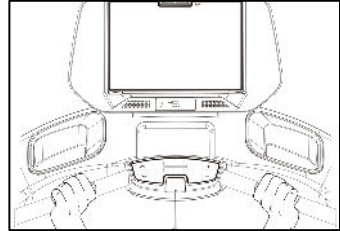

IMPORTANT: Read HOW TO TURN ON THE POWER (see page 11)
DANGER: Stand on side rails when starting the treadmill

START

1. Press the START button on the Console or the screen, and the belt will start to move.



As you exercise, change the speed of the walking belt as desired by pressing the speed increase and decrease buttons. Each time you press One of the buttons, the speed setting, will change by 0.1 km/h; if you hold down the button, the speed setting will change rapidly. Note: After you press the button, it may take a moment for the walking belt to reach the selected speed setting.

Press speed + / - buttons increase or decrease the treadmill speed; the walking belt will gradually change speed until it reaches the selected speed.

2. Change the incline of the treadmill as desired. To change the treadmill's incline, press the incline increase and decrease button on the Console or screen. Each time you press one of the buttons, the treadmill will gradually adjust to the selected incline setting.
3. Measure your heart rate if desired. You can measure your heart rate using the handgrip heart rate monitor.

To measure your heart rate, stand on the side rails, hold the pulse bar with your palms on the metal contacts, avoid moving your hands. When your pulse is detected, a heart symbol will appear, and your heart rate will be shown. For the most accurate heart rate reading, continue to hold the contacts for about 15 seconds.

4. To stop the walking belt, press the STOP button on the Console or screen. The walking belt will slowly come to a stop. You will be asked if you want to stop the session or resume the workout.

Step onto the side rails and press the STOP button again. Adjust the incline of the treadmill to zero. The incline must be returned to zero, or you may damage the treadmill. If the machine is turned off and you can still hear the motor, it is the incline coming down. Wait for the noise to stop completely before switching it off at the wall. It is now ready to be folded away in the storage position. Next, remove the safety key from the Console and put it in a secure place. When you are finished using the treadmill, press the power switch into the off position and unplug the power cord. **IMPORTANT:** If you do not do this, the treadmill's electrical components may wear prematurely.

HOW TO FOLD AND MOVE THE TREADMILL

FOLDING THE TREADMILL

To avoid damaging the treadmill, adjust the incline to zero before you fold the treadmill. Then, remove the key and unplug the power cord.

CAUTION: You must be able to safely lift 45 lbs. (20 kg) to raise, lower, or move the treadmill

1. Hold the end covers of the walking belt firmly.

CAUTION: Do not hold the frame by the plastic side rails. Bend your legs and keep your back straight.

2. Raise the frame until the kicker locks in the storage position.

CAUTION: Make sure that the kicker locks. To protect the floor or carpet, place a mat under the treadmill. Keep the treadmill out of direct sunlight. Do not leave the treadmill in the storage position in temperatures above 30° C.

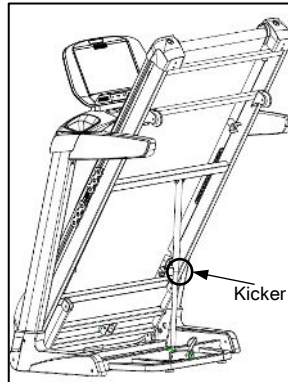
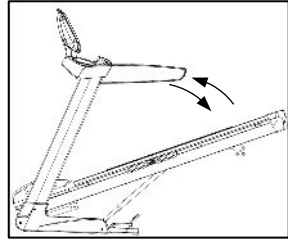

LOWERING THE TREADMILL

1. Push the upper end of the frame forward, and gently press the upper part of the kicker with your foot at the same time.

2. While pressing the kicker with your foot, slowly lower the frame slightly.

3. Step back and let the frame slowly lower to the floor by itself.

MOVING THE TREADMILL

1. Put the treadmill in the folded position before attempting to move it. Lift the rear of the treadmill slightly until the transportation wheel locks in place.

CAUTION: Make sure that the locking latch is locked in the storage position. Moving the treadmill may require two people.

2. Using both hands, hold onto the handlebars move the treadmill on the transportation wheels.

CAUTION: Do not pull on the frame, and do not move the treadmill over an uneven surface.

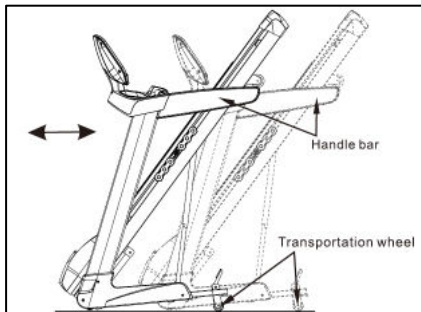
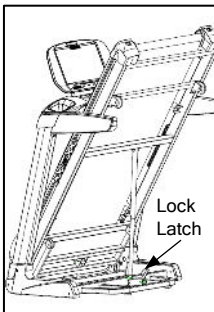

MAINTENANCE

For more information on maintaining your treadmill go to noble-pro.com/maintenance/

CLEANING

Regularly clean the treadmill and keep the walking belt clean and dry. First, press the power switch into the "OFF" position and unplug the power cord. Wipe exterior parts of the treadmill with a damp cloth and a small amount of mild soap.

IMPORTANT: Do not spray liquids directly onto the treadmill. To avoid damage to the Console, keep liquids away from the Console. Then, thoroughly dry the treadmill with a soft towel.

BELT LUBRICATION

The walking belt is lubricated with a high-performance silicone lubricant to reduce the friction between the walking belt and the running board. If the lubrication is inadequate, the belt will not operate smoothly. Remove the safety key and UNPLUG THE POWER CORD. Run your finger along the underside of the belt. If there is no lubricant residue on your finger's lubrication is needed.

To add lubrication to the walking belt. Remove the key and UNPLUG THE POWER CORD. Lift the walking belt in the centre of the running board. Add 15 ml of treadmill silicone lubricant on both sides of the walking belt as close to the belt's centre as possible. Turn the treadmill on using easy start mode and let it run for 10 mins at 12 km/h. Repeat the process until there is an even film of lubricant on the walking belt. **IMPORTANT:** Excessive lubrication might result in the walking belt or transition belts slipping and loss of drive.

ADJUSTING THE WALKING BELT

If the walking belt is off centre, remove the safety key and UNPLUG THE POWER CORD.

If the walking belt has shifted to the left (viewed from the back), use the 6mm hex key to turn the left idler roller screw clockwise $\frac{1}{2}$ a turn; if the walking belt has shifted to the right (viewed from the back), turn the right idler roller screw counter-clockwise $\frac{1}{2}$ a turn.

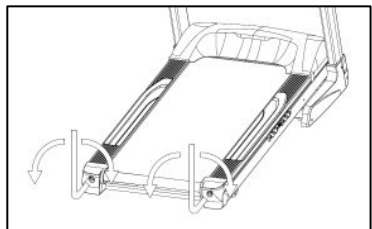

Then, plug in the power cord, insert the safety key and run the treadmill for a few minutes.

Repeat until the walking belt is centred. **CAUTION:** Be careful not to overtighten the walking belt as it might reduce the bearings' longevity.

TIGHTENING OF THE WALKING BELT

If the walking belt slips when walked on, first remove the key and UNPLUG THE POWER CORD.

Using the 6 mm hex key, turn both idler roller screws a $\frac{1}{4}$ of a turn clockwise at a time until you can lift each edge of the walking belt 3 to 4 inches (8 to 10 cm) off the walking board.

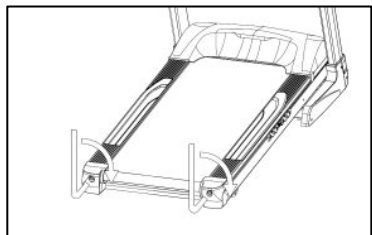

Be careful to keep the walking belt centred. Then, plug in the power cord, insert the safety key, and carefully walk on the treadmill for a few minutes. Repeat until the walking belt is sufficiently tightened.

LOOSENING THE WALKING BELT

IMPORTANT: If the walking belt is overtightened, treadmill performance may decrease, and the walking belt and bearings might become damaged.

To loosen the walking belt, first, remove the key and **UNPLUG THE POWER CORD**. Then using the hex key, turn both idler roller screws a $\frac{1}{4}$ a turn counter clockwise at a time until you can lift each edge of the walking belt 3 to 4 inches (8 to 10 cm) off the walking board. Be careful to keep the walking belt centred. Then, plug in the power cord, insert the safety key and run the treadmill for a few minutes. Repeat until the walking belt is properly tightened.

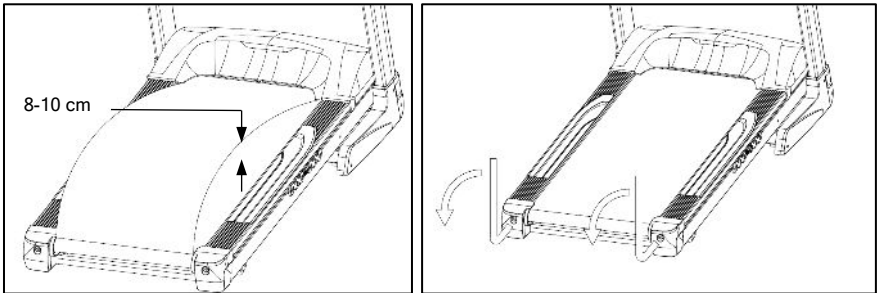

TROUBLESHOOTING

Issue	Possible Causes	Solution
The treadmill does not turn on	A No power	Plug in the power cable
	B Safety key not detected	Insert safety key
	C Faulty communication circuit	Check control panel and communication cables
	D Treadmill power switch in "OFF" position	Turn the power switch to the "ON" position
	E Blown fuse	Replace the fuse
The console screen does not display anything	The power cord is not connected	Connect the power cord and check the socket
	B The power switch is on the "OFF" position	Turn the power switch to the "ON" position
	C Power overload or damaged driver	Push the overload protection button. Replace the driver
	D Communication cable faulty	Replace the communication cable
	E Digital watch is damaged	Replace the digital watch
	F (LCD) backlight is not bright	Adjust, replace or repair the backlight
The treadmill display is missing characters	A An issue with the display connections	Repair or replace display they
	B The display is not fixed in position and sliding around	Repair or replace the splay
	C Faulty display driver IC	Repair or replace display driver IC
Treadmill walking belt not moving smoothly	An Excessive resistance on the transmission system	Adjust the transmission parts and / or lubricate accordingly
	B Walking belt is too tight	Loosen walking belt
	C Walking belt is too loose	Tighten walking belt
	D Torque requirements too small or too high	Adjust the torque potentiometer accordingly
	E Lack of walking belt lubrication	Lubricate the walking belt as directed in the user manual
	F Motor belt is slipping	Tighten the motor belt
	G Over lubrication	Remove excessive lubrication on walking belt and drive belt
Static shock	Static electricity is not being earthed	Ensure the plug earth quality is good
	B High static cloths used during exercise	Use natural material clothing during exercise
Buzzing noise	A Plug power is out of phase	Inspect the plug outlet phase quality
	B Incorrect voltage supply	Ensure the correct voltage is supplied to the treadmill

Issue	Possible Causes	Solution
Safety key	A Missing safety key	Place the safety key in the designated area
	B Faulty magnetic sensor	The safety key magnetic sensor is stuck. Repair or replace magnetic sensor.
Communication failure	A Communication cable faulty	Reconnect the communication cables
	B Damaged communication cable	Replace communication cable
	C Communication cable connection faulty	Replace effected cables
	D IC drive cable faulty	Replace the IC drive cable
Motor stalls	A Loose motor connection cables	Check wire connections are tight or replace the motor
	B Motor controller board faulty	Replace the IC drive
	C External ac voltage is too low	Undertake electrical supply troubleshooting where the treadmill is plugged in
Incline motor stalling	A Faulty incline motor connection	Check wire connections are tight or replace the motor
	B Faulty incline motor	Replace incline motor
	C Faulty IC drive	Replace the IC drive
Over-current protection	A Treadmill overloaded	Rotate the motor by hand and safely try again
	B Excessive friction in driver motors	Inspect and maintain transmission components
	C Motors damaged	Replace motor
	D Motor controller damaged	Replace IC drive
Motor error	A Motor cable connection faulty	plug machine line again
	B Motor is shorting internally	change the motor
	C Motor is idling	The motor current is too low. Replace the motor

EXPLODED DRAWING 1

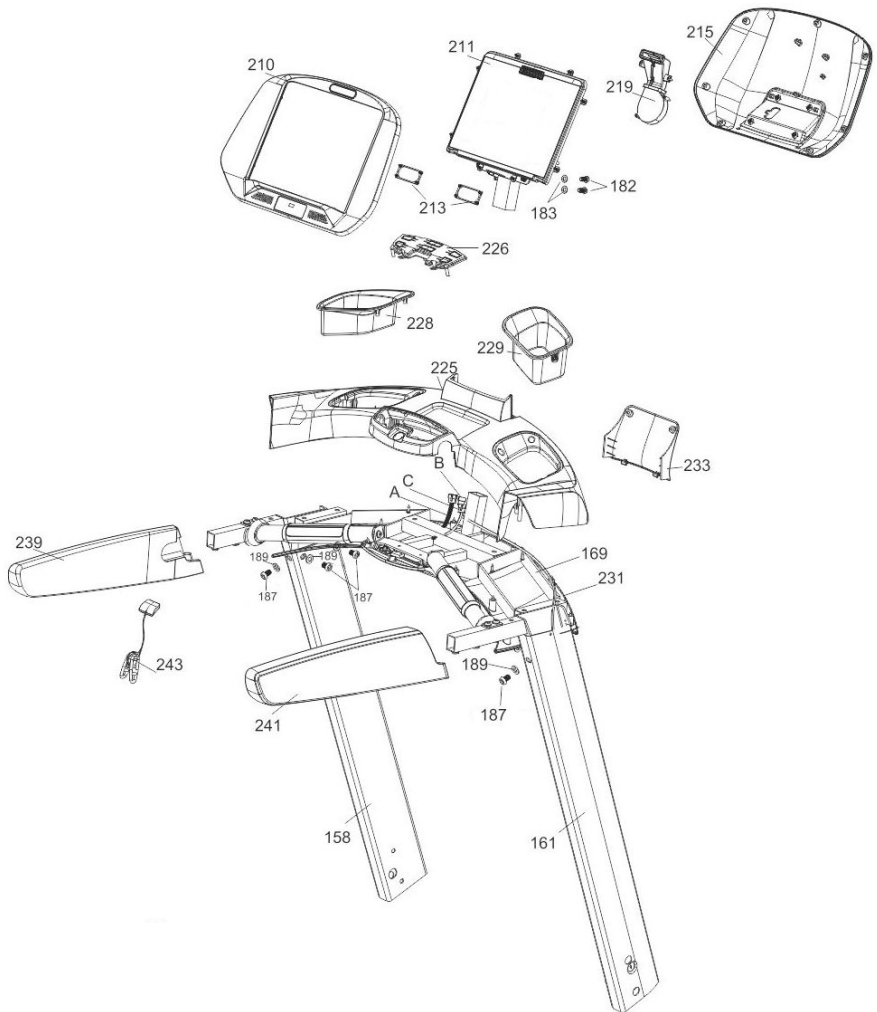

EXPLODED DRAWING 2

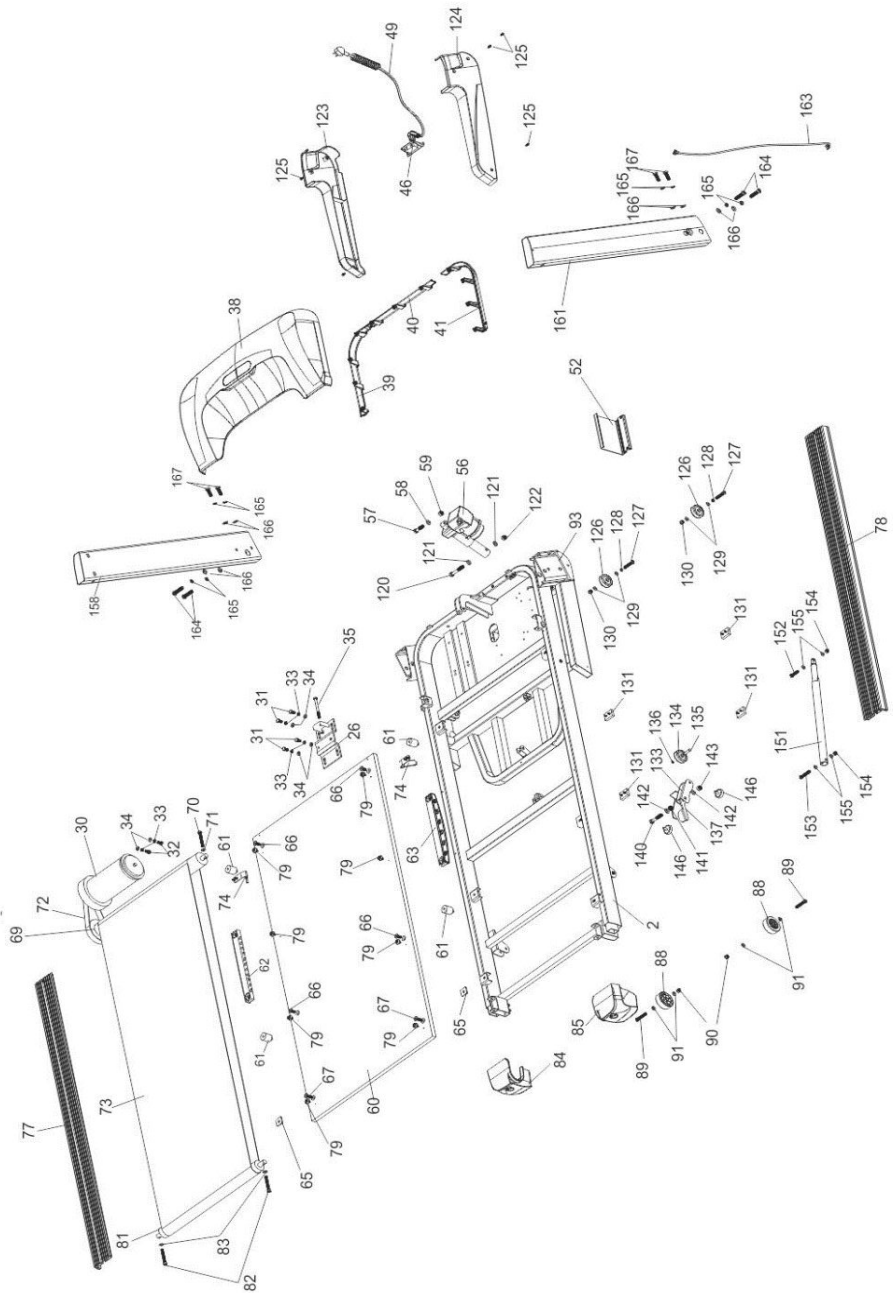

PARTS LIST

No. Part	Description	QTY	No. Part	Description	QTY
2	Base frame	1	126	Front wheel	2
26	Motor base plate	1	127	Allen key M8×45 screw	2
30	Motor	1	128	Washer Ø8×2.1	2
31	Socket M8×16 bolt	4	129	Flat washer Ø8×1.6	2
32	Socket M8×12 bolt	2	130	Nut M8	2
33	Spring washer Ø8×2.1	6	131	Rubber pad	4
34	Flat washer Ø8×1.6	6	133	Transportation wheel frame	1
35	Socket M8×90 screw	1	134	Transportation wheel	1
38	Motor cover	1	135	Transportation wheel shaft	1
39	Motor cover insert	1	136	Elastic ring - type B trunnion 8 (shaft)	1
40	Motor cover insert	1	137	Transportation lever	1
41	Motor cover insert	1	140	Socket M10×55 bolt	1
46	Plug with switch	1	141	Torsional spring	1
49	Power cord with plug	1	142	Flat washer Ø10×2	2
52	IC Driver	1	143	Nut M10	1
55	4 Cores wire	1	146	Height adjusting pad	2
56	Incline motor	1	151	Storage cylinder (775×500-45KG)	1
57	Socket M10×45 bolt	1	152	Allen key M8×35 screw	1
58	Flat washer Ø10×2	2	153	Allen key M8×50 screw	1
59	Nut M10	1	154	Nut M8	2
60	Running board	1	155	Flat washer Ø8×1.6	4
61	Shock absorber	2	158	Left post	1
62	Shock absorber	1	161	Right post	1
63	Shock absorber	1	163	Communication cable	1
65	Rubber pad	2	164	Allen key M10×45 screw	4
66	Philips countersunk head screw M8×25	4	165	Spring washer Ø10×2.5	8

No. Part	Description	QTY	No. Part	Description	QTY
67	Philips countersunk head screw M8×35	2	166	Flat washer Ø10×2	8
69	Front roller	1	167	Allen key M10×30 screw	4
70	Socket M8×60 bolt	1	169	Monitor console base	1
71	Flat washer Ø10×2	2	182	Allen key M8×16 screws	2
72	Motor belt	1	183	Flat washer Ø8×1.6	2
73	Running belt	1	187	Allen key M10×16 screw	6
74	Guiding hook	2	188	Spring washer Ø10×2.5	6
77	Left side rail	1	189	Washer Ø10×2	6
78	Right side rail	1	210	Monitor front cover	1
79	Side rail buckle	8	211	Monitor display board	1
81	Rear roller	1	213	Square speaker	2
82	Socket M8×60 screw	2	215	Monitor back cover	1
83	Flat washer Ø8×1.6	2	219	Monitor fans	
84	Left end cap	1	225	Monitor console up cover	1
85	Right end cap	1	226	Monitor up PCB board	1
88	Rear-wheel	2	228	Left cup	1
89	Allen key M8×45 screw	2	229	Right cup	1
90	Nut M8	2	231	Monitor console bottom cover	1
91	Flat washer Ø8×1.6	4	233	Monitor back cover	1
93	Frame holder	1	239	Left-arm	1
120	Socket M10×65 bolt	1	241	Right arm	1
121	Flat washer Ø10×2	2	243	Safety key	1
122	Nut M10	1	A	6 Cores wire	1
123	Left side cover	1	B	4 Cores wire	1
124	Right side cover	1	C	6 Cores wire	1
125	ST4.2×13	6			

ORDERING REPLACEMENT PARTS

To order replacement parts, please see the front cover of this manual. To help us assist you, be prepared to provide the following information when contacting us:

- the model number and serial number of the product
- the name of the product (see the front cover of this manual)
- the part number and description of the replacement part(s) (see the PART LIST and the EXPLODED DRAWINGS page 20-23)

WARRANTY

Offered by NOBLEPRO LIMITED ("NoblePro")

All NoblePro products are warranted for use within a private, domestic, non-fee-paying environment. The warranties are non-transferable as they are only valid for the original owner (purchaser) of the equipment. The warranty will not apply if the product is used other than domestic use. It is not operated according to the operating manual supplied, or the product leaves the country it was supplied in. The warranties are subject to the product been used as intended and maintained, and serviced as prescribed. Abuse or inappropriate use of the product will be excluded from the warranty.

NoblePro warrants this product to be free from defects in workmanship and material.

The STANDARD WARRANTY is for a period of 12 months, if not registered. The STANDARD WARRANTY includes the frame of the equipment in question with its motor. The labour applicable here is also included.

When the product is purchased, it needs to be registered online at noble-pro.com/product-registration within 30 days after purchase to qualify for the EXTENDED WARRANTY. For further information about your warranty, please go to noble-pro.com/warranty/.

All repairs or replacement needs to be authorized by NoblePro. NoblePro will not reimburse for any transport or courier service and arrange for the product to be collected either by NoblePro or a third party. The warranty is related to the delivery address of the client, and additional collection and delivery fees may be applicable due to the extended distance. The client consents to NoblePro to assess the product and repair it if required on the premises where the product is located. The client or any other party may not conduct any repair work on the machine other than the normal service and maintenance as per the operating manual supplied. The warranty excludes explicitly cases where the product was altered, modified, damaged or repaired by any party other than NoblePro. The warranty does not cover damage caused by fire, lightning, accidents, water damage (including humidity), pollution (such as fumes, dust and chemicals) or earthquakes.

The process to act on the warranty includes the notification of NoblePro, which include the nature of the problem encountered and the serial number of the equipment. If it is a minor repair, NoblePro may guide the client to rectify the matter. A charge will be levied to collect and deliver the product, but if the product was identified with a defect, this charge would be reimbursed when the product is fixed and returned to the customer.

NoblePro has the right to replace the product with a similar product in terms of condition and specifications of the product sold to the customer.

NoblePro is not responsible or liable for any expense, liability, loss, or proceeding whatsoever in respect of any personal injury related to the equipment or any damages, economic loss including loss of revenue, loss of enjoyment or training or any other consequential damages that are permitted by law.