

FORCE USA

C10 SLIDING BENCH

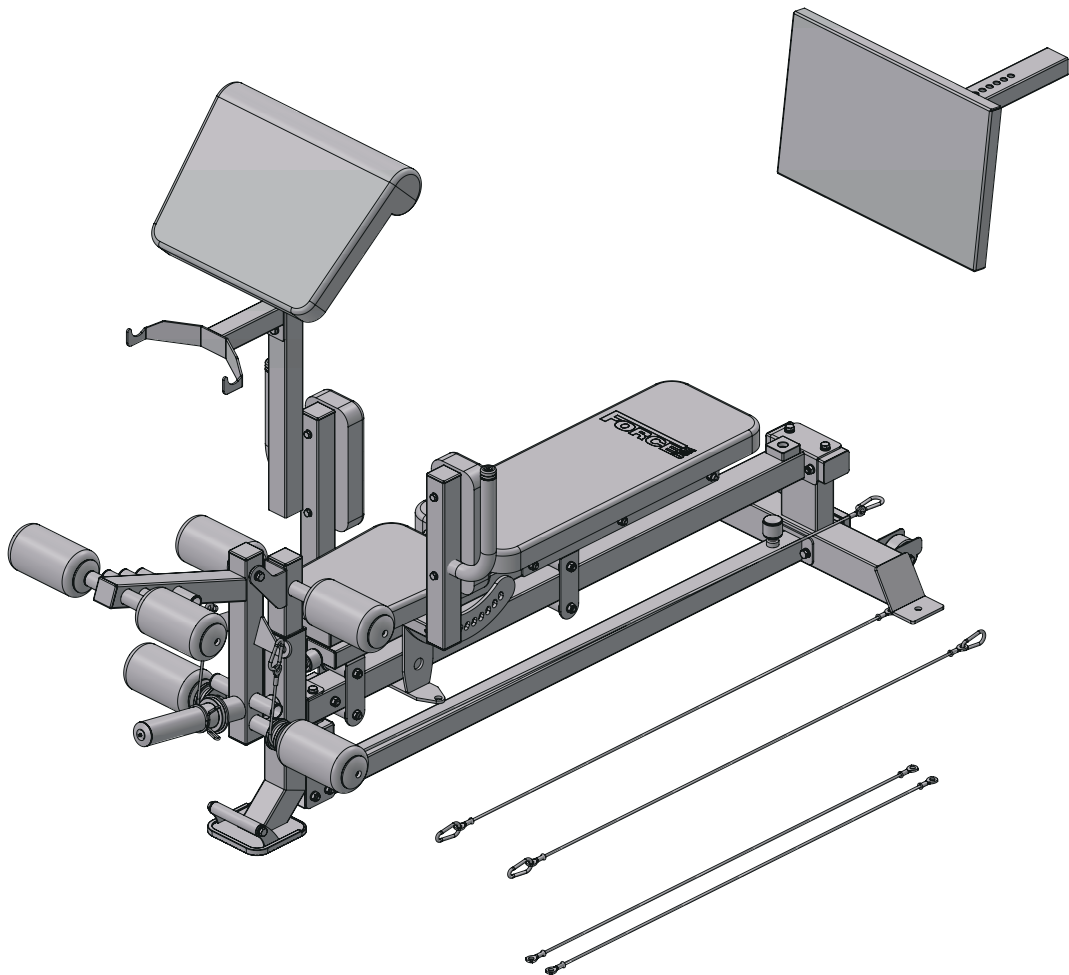

TABLE OF CONTENTS

SECTION	PAGES
Before you Start and Safety Information	2
ForceUSA App	3
Preventative Maintenance	4
Parts Identification.....	5-10
Assembly Steps	11-26
Exploded Diagrams	30-42
Parts Lists	43-45
Warranty Information	46

USER MANUAL

Before You Start

- Read all instructions in this manual before assembling or using this equipment
- Remove all parts from the packaging and count each component separately to ensure everything is provided correctly, noting that some items may be pre-assembled
- Follow the instructions and refer to both the individual assembly pages and the exploded views of the equipment whenever possible
- The owner is responsible for ensuring that all users of this unit have read the user manual and understand the safety precautions
- Descriptions of left and right refer to the perspective of standing in front of the equipment
- Place all parts in a cleared area and remove the packing materials. Do not dispose of the packing materials until all assembly steps are completed
- Machines with a counterbalanced smith bar require up to one meter of clearance above the assembled height to insert the counterbalances. If there is not enough clearance, insert the counterbalances into the required framing components before assembly and securely anchor off the cables to ensure they can be retrieved and attached as needed
- It is recommended to keep these instructions

Safety Precautions

- It is highly recommended that two or more people are used for assembly
- Assemble equipment on a flat surface
- Consider placing a mat/mats under the equipment to protect your floor
- Only tighten nuts and bolts loosely until all equipment is assembled. Once the equipment is fully assembled each bolt can be tightened working evenly around the equipment where possible
- Ensure all parts are in working order prior to use
- Make sure all pivoting components are able to move freely
- Do not use or store the equipment outdoors or around water
- Do not over tighten any component with pivoting function
- Keep hair, fingers and clothing away from moving parts
- Only use attachments recommended by the manufacturer
- Never operate if parts are not functioning correctly
- Always stretch prior to using equipment
- Stop immediately if you experience any pain, dizziness or nausea
- Before starting any exercise program consult your doctor

FORCE USA TRAINING APP

The Force USA training app offers programs, tutorials, progress tracking and more. Not compatible with all Force USA equipment.



PREVENTATIVE MAINTENANCE

To ensure your equipment is operating at its peak, please follow the below preventative maintenance schedule performing all tasks upon initial assembly:



Daily Maintenance

- Wipe down the equipment to remove any dust and sweat residue with a dry, non-abrasive cloth
- Inspect the unit for noisy, damaged or loose components



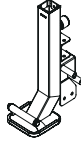
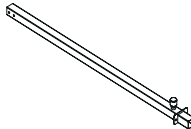
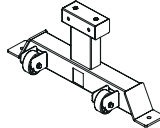
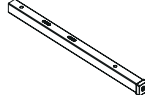
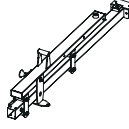
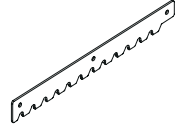
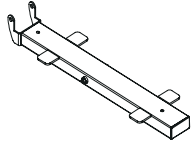
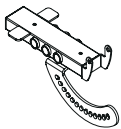
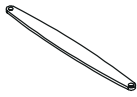

Monthly Maintenance

- Thoroughly clean the equipment using a non abrasive cloth dampened with a mild, all purpose cleaner ensuring to thoroughly wipe down and dry the equipment afterwards
- Apply a 100% silicone lubrication (preferably spray) to guide rods, pulley sliders, weight plate carriages and any other moving parts where friction can occur including bearings (where applicable). Any other form of lubrication will void your warranty
- Check the tightness of all bolts, nuts and screws
- Check the cables for fraying or any signs of wear and ensure they are at the correct tension with a small amount of slack at resting position (where applicable)
- Inspect pulleys for any damage or cracks (where applicable)
- Knurling can be cleaned using a soft bristled brush to help remove any particles that may be nestled within the knurling
- Vacuum around the machine/equipment to prevent dust acclimation

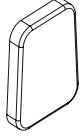

PARTS IDENTIFICATION

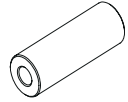
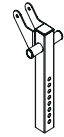
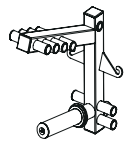
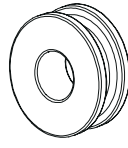
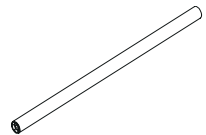
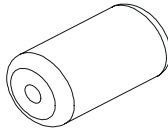
Key No.	Description	Quantity	Parts Schematic Diagram
1	Front Base Frame	1	
2	Middle Base Frame	1	
8	Rear Base Frame	1	
9	Internal Support Beam	1	
10	Sliding Frame	1	
14	Locking Plate	2	
16	Back Pad Frame	1	
18	Seat Pad Frame	1	
19	Pad Adjustment Plate	2	
24	Back Pad	1	

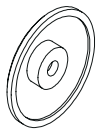
PARTS IDENTIFICATION

Key No.	Description	Quantity	Parts Schematic Diagram
25	Seat Pad	1	
27	Pulley	4	
29	Leg Curl Extension Inner Shaft	1	
30	Leg Curl Extension Mounting Frame	1	
31	Leg Curl Extension Frame	1	
32	Pulley	2	
33	Foam Pad Rod	3	
34	Upper Foam Pad	4	
35	Foam Pad Inner Cover Plate	4	
36	Foam Pad Outer Cover Plate	6	

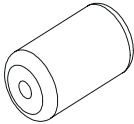
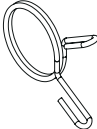
PARTS IDENTIFICATION

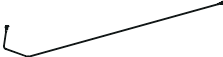
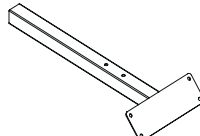
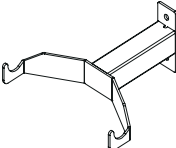
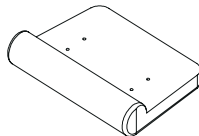
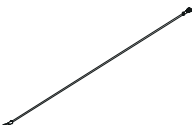
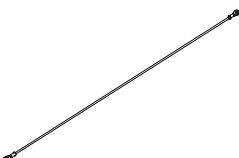
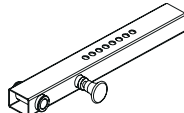
Key No.	Description	Quantity	Parts Schematic Diagram
37	Lower Foam Pad	2	
39	Spring Collar	1	
40	Carabiner	8	
41	Leg Curl Cable	2	
42	Preacher Curl Frame	1	
43	Preacher Curl Barbell Holder	1	
44	Preacher Curl Pad	1	
47	Leg Press Hack Squat Cable - Green	2	
48	Leg Press Hack Squat Cable - Red	2	
49	Leg Press Hack Squat Plate Adjustment Frame	1	

PARTS IDENTIFICATION

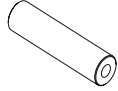
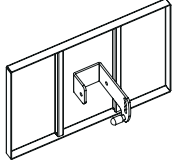
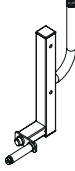
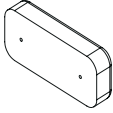
Key No.	Description	Quantity	Parts Schematic Diagram
50	Inner Shaft	1	
51	Leg Press Hack Squat Plate	1	
52	Shoulder Pad Frame	2	
54	Shoulder Pad	2	

PARTS IDENTIFICATION

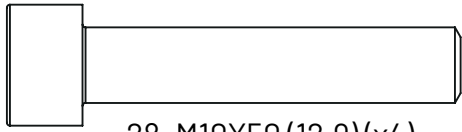

28. M10X50 (12.9)(x4)

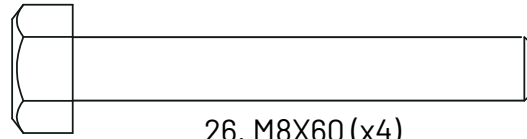

26. M8X60 (x4)



17. ϕ 12X118-M10 (x1)



20. ϕ 12X130-M10 (x1)

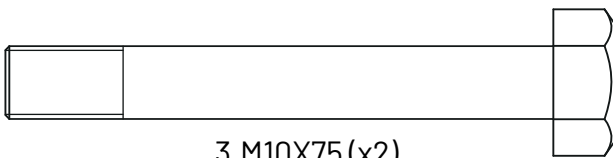

3. M10X75 (x2)

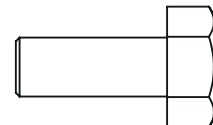

46. M8X20 (x4)

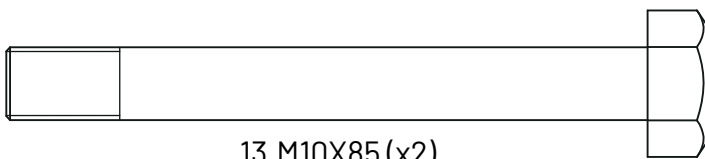

13. M10X85 (x2)

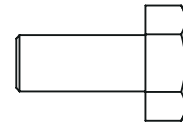

22. M8X16 (x2)

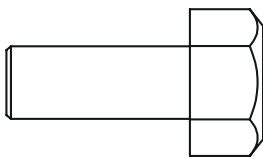

6. M10X25 (x8)

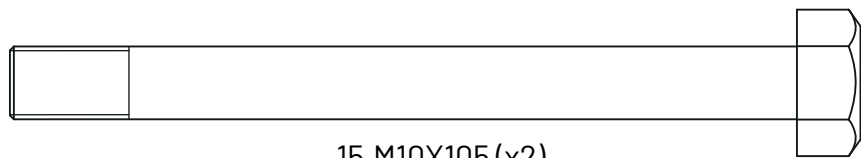

15. M10X105 (x2)

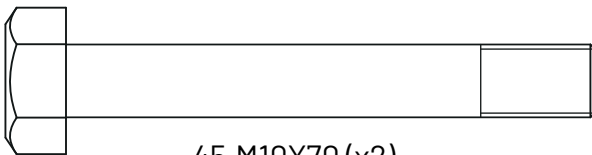

45. M10X70 (x2)



53. M8X65 (x4)

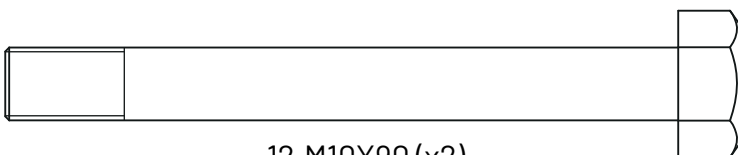

12. M10X90 (x2)

PARTS IDENTIFICATION

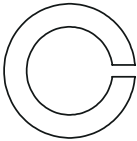

7. $\varnothing 10 (x12)$

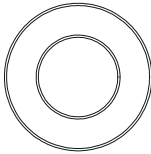

5. $\varnothing 10 (x35)$

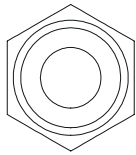

4. M10 (x15)

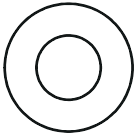

21. $\varnothing 8 (x14)$

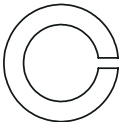

23. $\varnothing 8 (x2)$

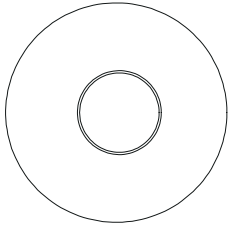

11. $\varnothing 30^* \varnothing 10.5^* T3 (x4)$

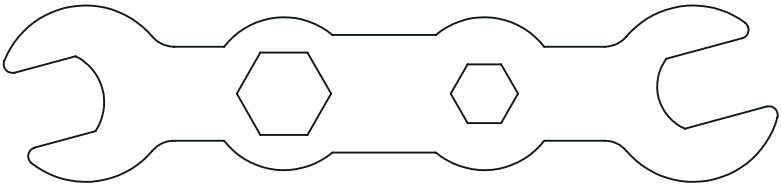

1PCS

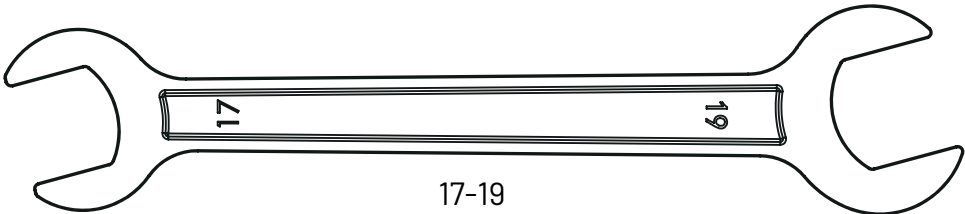

17-19
2PCS

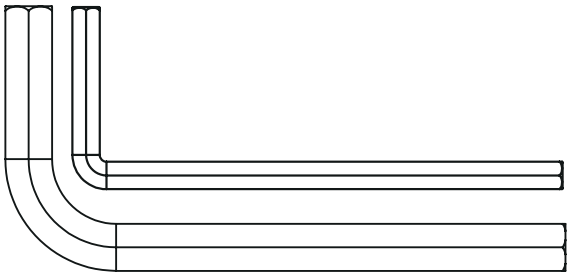

5. 8MM
1PCS

ASSEMBLY STEP 1

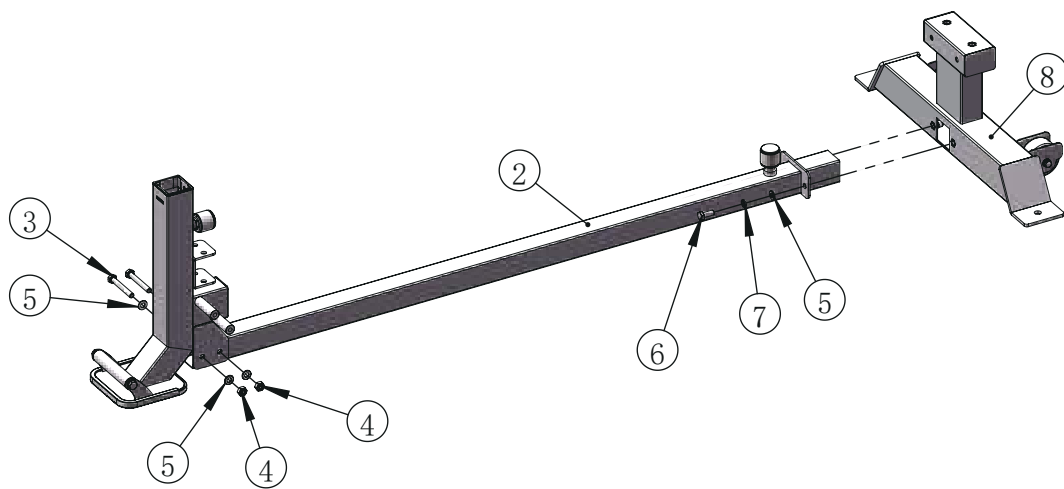

Key No.	Description	Note	Quantity
1	Front Base Frame		1
2	Middle Base Frame		1
3	Hexagon Head Bolt	M10×75	2
4	Lock Nut	M10	2
5	Washer	φ10	6
6	Hexagon Head Bolt	M10×25	2
7	Spring Washer	φ10	2
8	Rear Base Frame		1

ASSEMBLY STEP 2

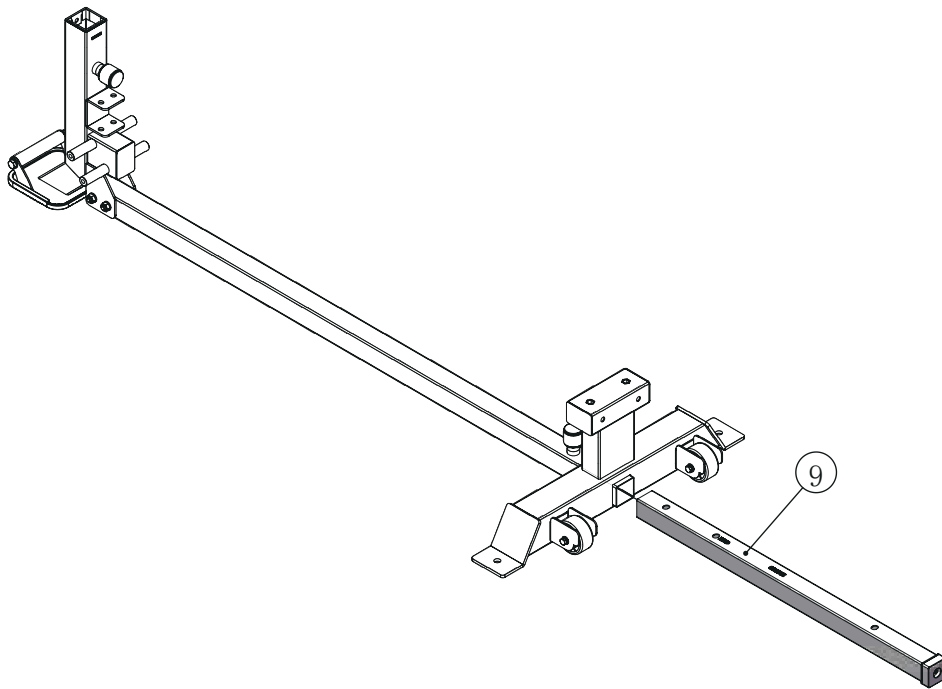

Key No.	Description	Note	Quantity
9	Internal Support Beam		1

ASSEMBLY STEP 3

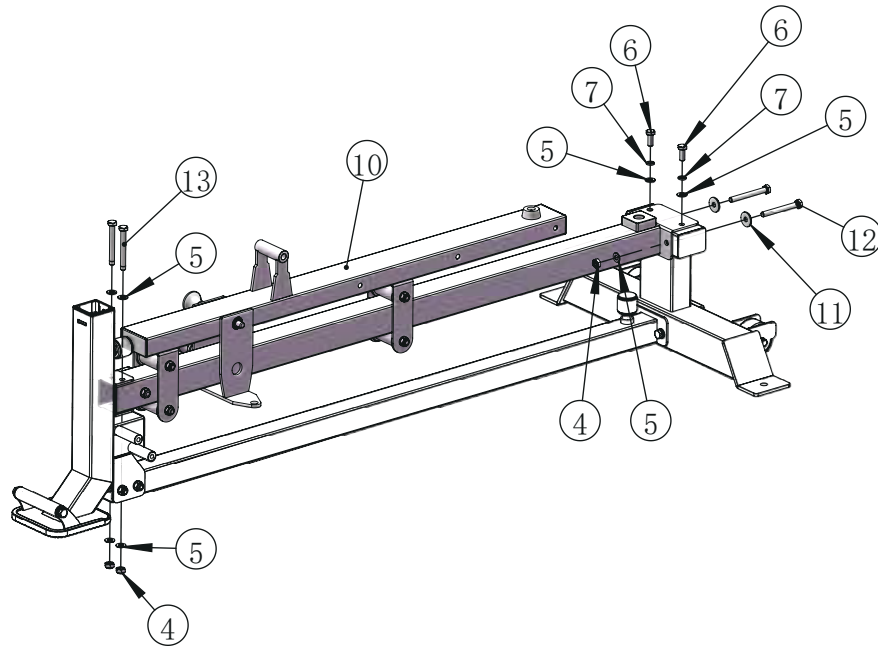

Key No.	Description	Note	Quantity
4	Lock Nut	M10	4
5	Washer	$\phi 10$	9
6	Hexagon Head Bolt	M10 \times 25	2
7	Spring Washer	$\phi 10$	2
10	Sliding Frame		1
11	Large Washer	$\phi 10$	2
12	Hexagon Head Bolt	M10 \times 90	2
13	Hexagon Head Bolt	M10 \times 85	2

ASSEMBLY STEP 4

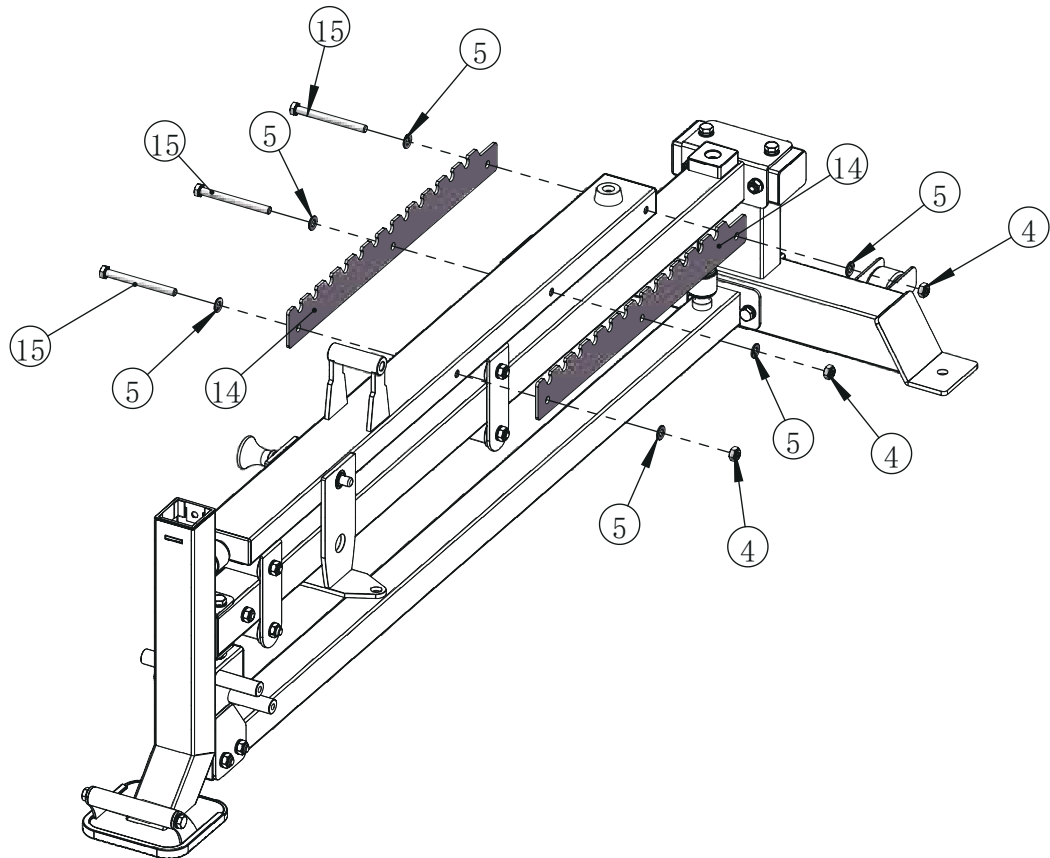

Key No.	Description	Note	Quantity
4	Lock Nut	M10	3
5	Washer	φ10	6
14	Locking Plate	T4	2
15	Hexagon Head Bolt	M10×105	3

ASSEMBLY STEP 5

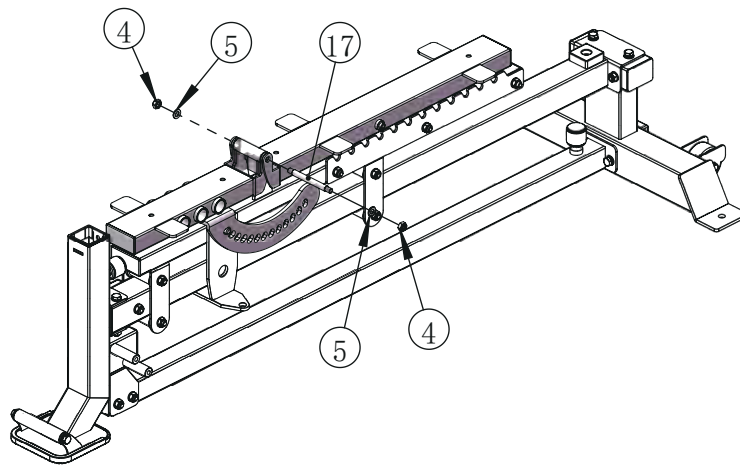

Key No.	Description	Note	Quantity
4	Lock Nut	M10	2
5	Washer	φ10	2
16	Back Pad Frame		1
17	Double Head Bolt	φ12*M10*118	1
18	Seat Pad Frame		1

ASSEMBLY STEP 6

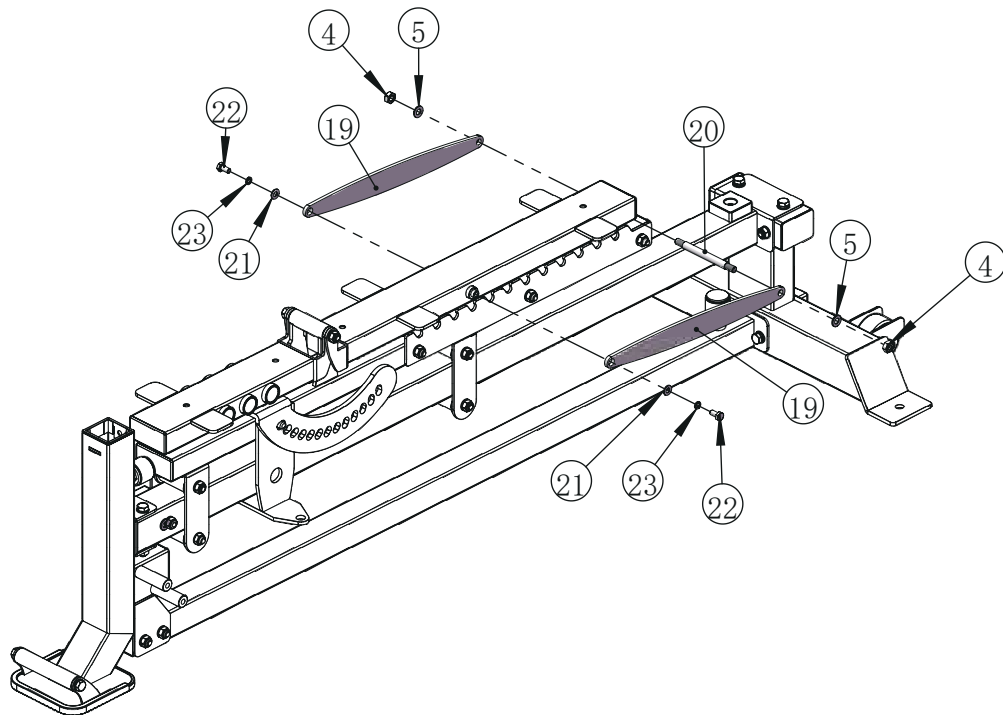

Key No.	Description	Note	Quantity
4	Lock Nut	M10	2
5	Washer	$\phi 10$	2
19	Pad Pad Adjustment Plate	T6	2
20	Double Head Bolt	$\phi 12 \times 130 - M10$	1
21	Washer	$\phi 8$	2
22	Hexagon Head Bolt	M8 \times 16	2
23	Washer	$\phi 8$	2

ASSEMBLY STEP 7

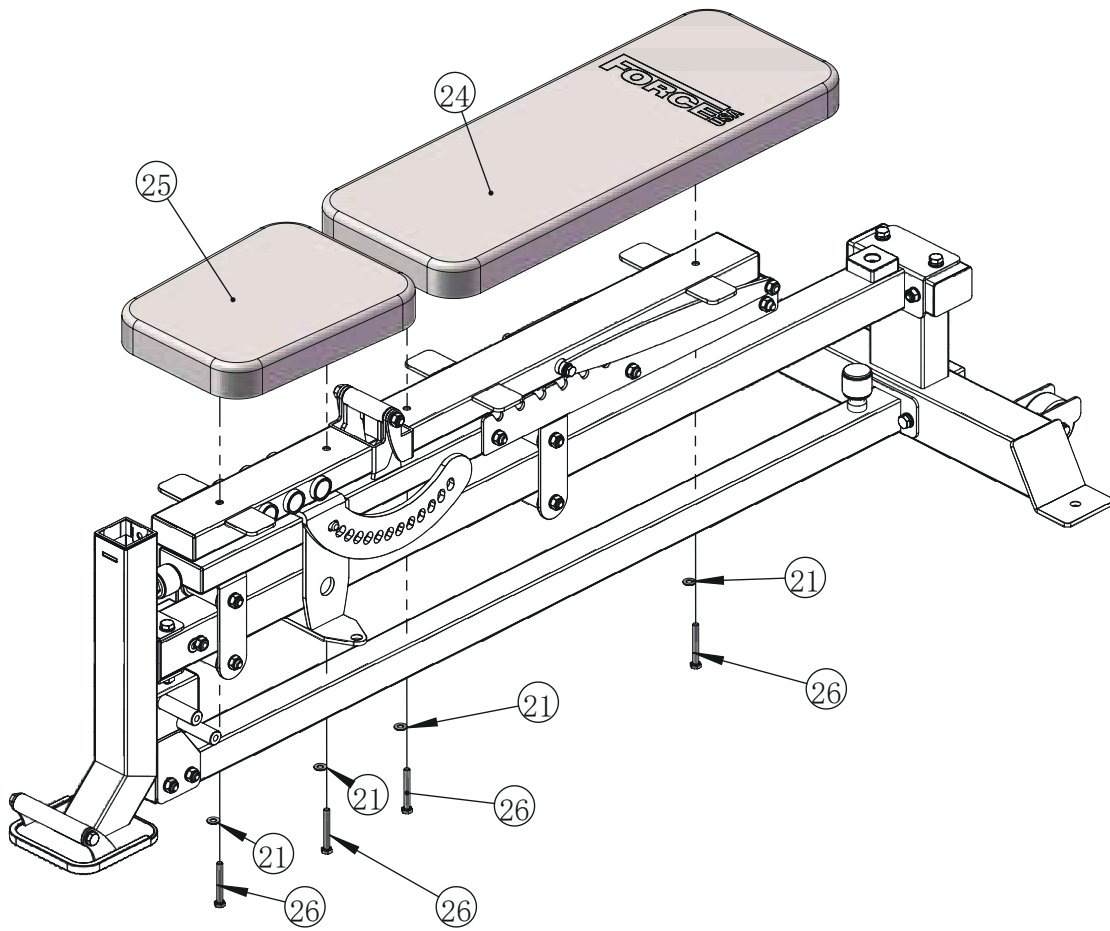

Key No.	Description	Note	Quantity
21	Washer	$\phi 8$	4
24	Back Pad		1
25	Seat Pad		1
26	Hexagon Head Bolt	M8×60	4

ASSEMBLY STEP 8

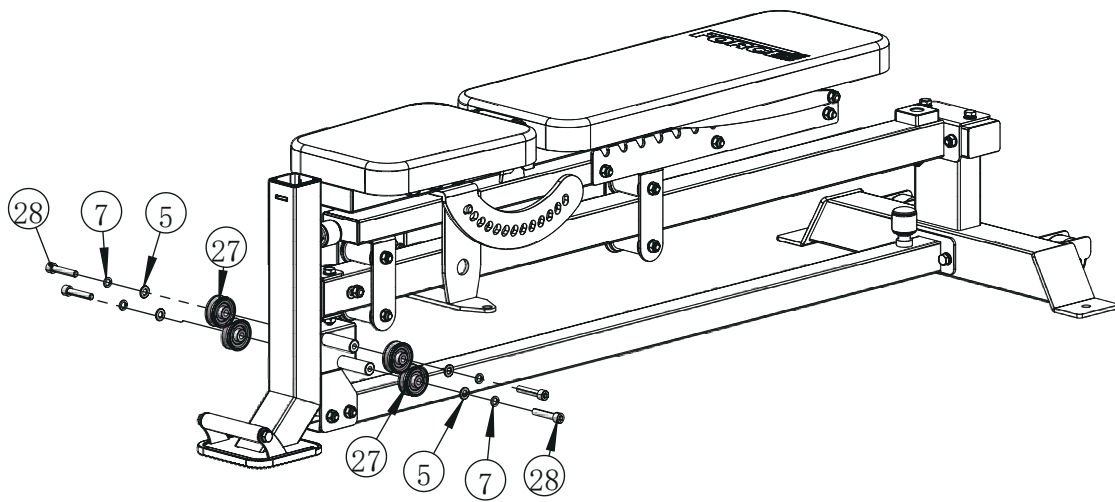

Key No.	Description	Note	Quantity
5	Washer	φ10	4
7	Spring Washer	φ10	4
27	Pulley	φ50	4
28	Inner Hexagon Column Head Bolt	M10×50	4

ASSEMBLY STEP 9

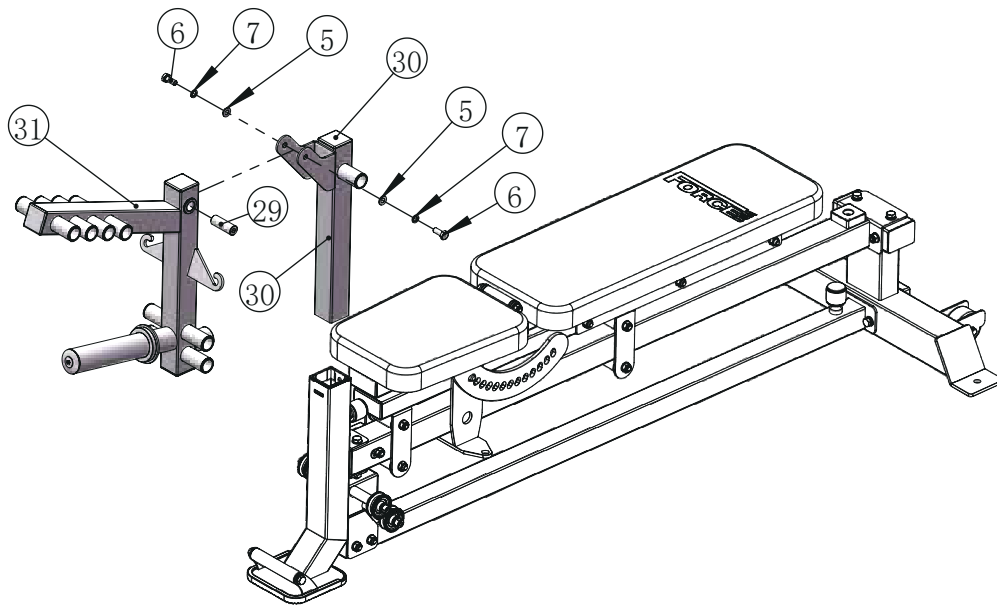

Key No.	Description	Note	Quantity
5	Washer	φ10	2
6	Hexagon Head Bolt	M10×25	2
7	Spring Washer	φ10	2
29	Leg Curl Extension Inner Shaft	φ20×57-M10	1
30	Leg Curl Extension Mounting Frame		1
31	Leg Curl Extension Frame		1

ASSEMBLY STEP 10

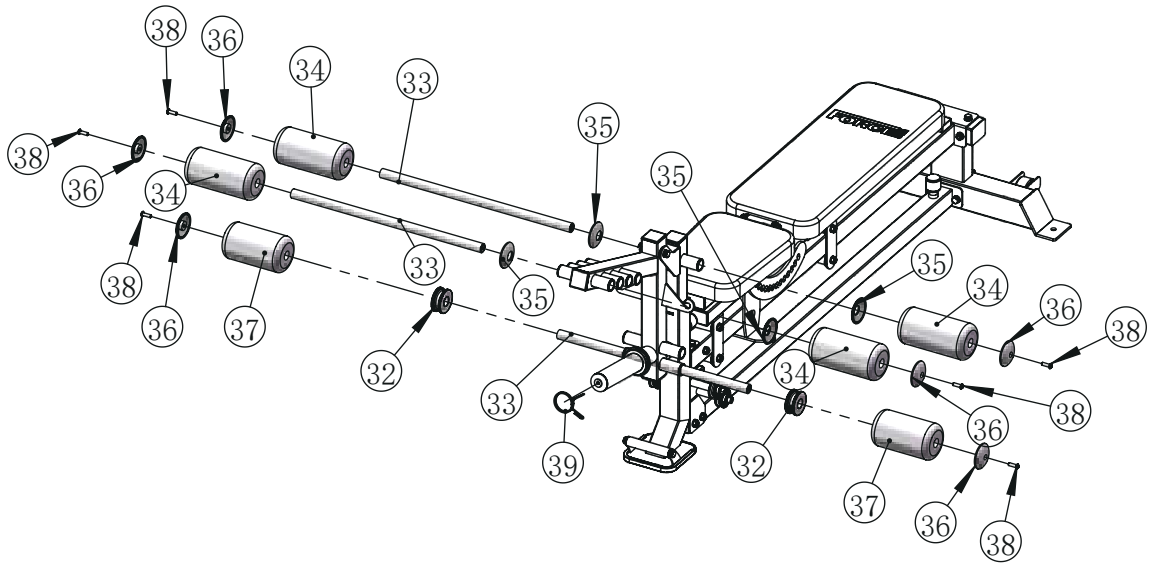

Key No.	Description	Note	Quantity
32	Pulley	$\phi 78 \times \phi 26 \times 28$	2
33	Foam Pad Rod		3
34	Upper Foam Pad	$\phi 25 \times \phi 100 \times 200$	4
35	Foam Pad Inner Cover Plate	$\phi 70 \times \phi 27 \times 12$	4
36	Foam Pad Outer Cover Plate	$\phi 70 \times \phi 9 \times 14$	6
37	Lower Foam Pad	$\phi 25 \times \phi 100 \times 175$	2
38	Hexagon Socket Button Head Screw	M8×25	6
39	Spring Collar	$\phi 50$	1

ASSEMBLY STEP 11

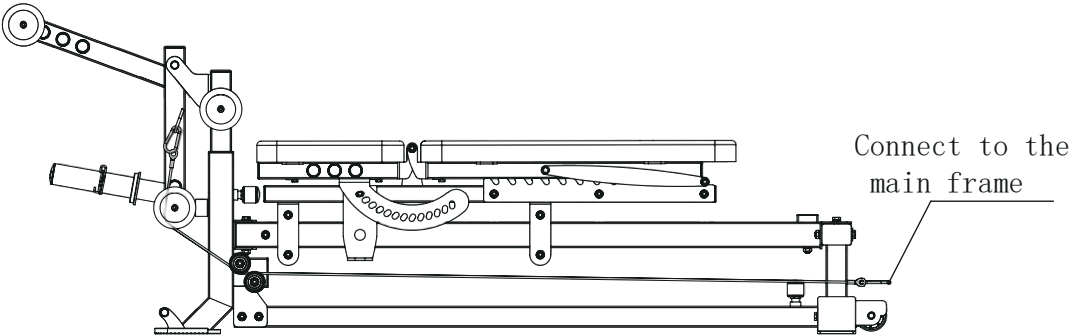
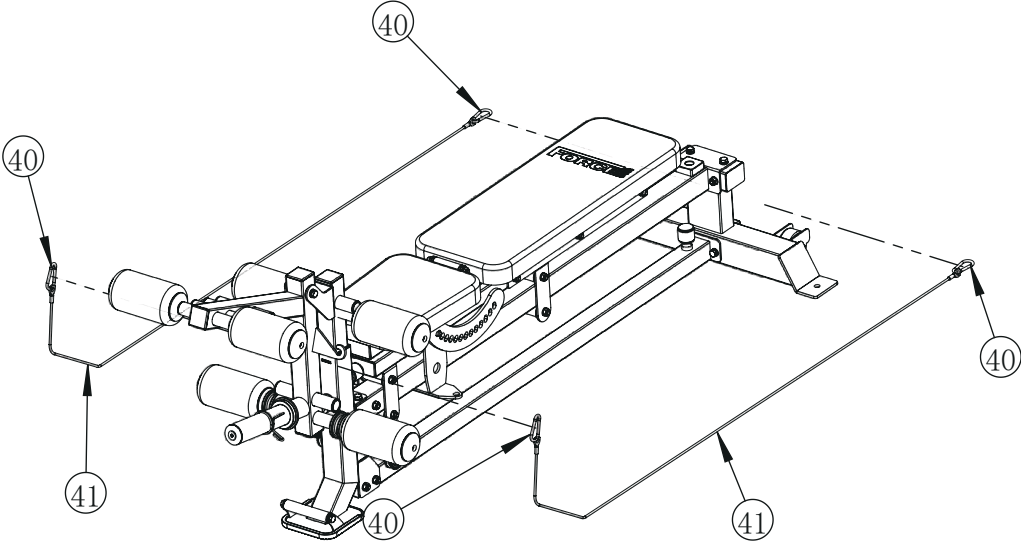

Key No.	Description	Note	Quantity
40	Carabiner		4
41	Leg Curl Cable		2

ASSEMBLY STEP 12

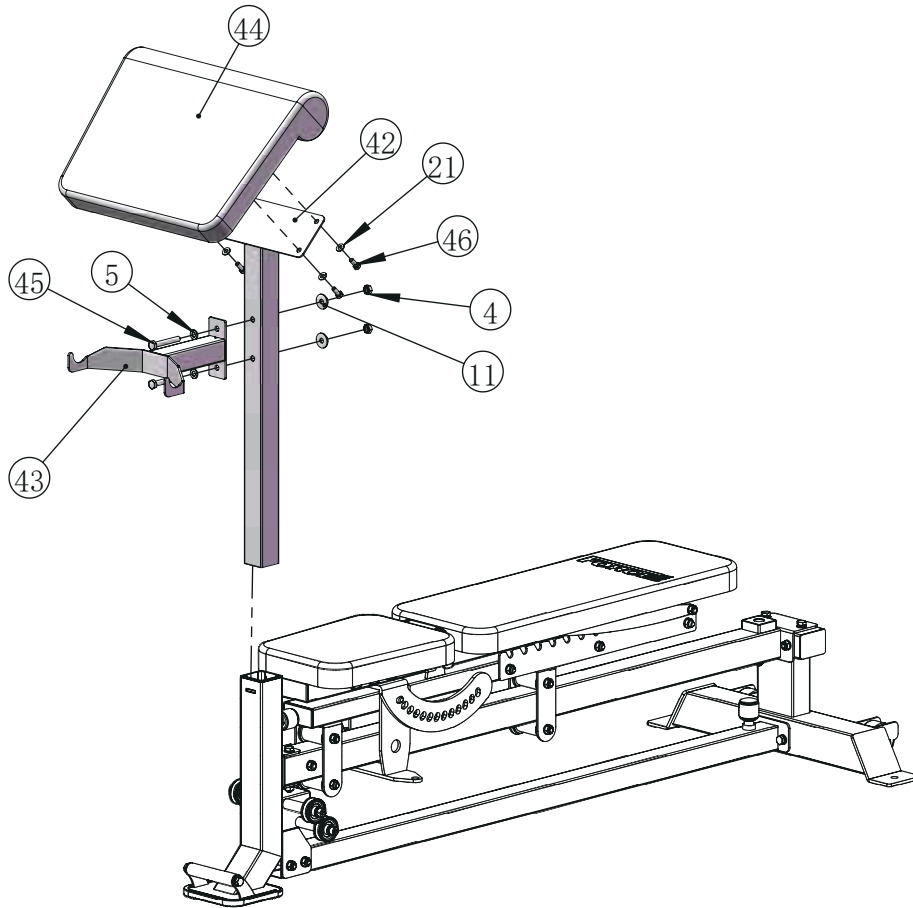

Key No.	Description	Note	Quantity
4	Lock Nut	M10	2
5	Washer	φ10	2
11	Large Washer	φ10	2
21	Washer	φ8	4
42	Preacher Curl Frame		1
43	Preacher Curl Barbell Holder		1
44	Preacher Curl Pad		1
45	Hexagon Head Bolt	M10×70	2
46	Hexagon Head Bolt	M8×20	4

ASSEMBLY DRAWING

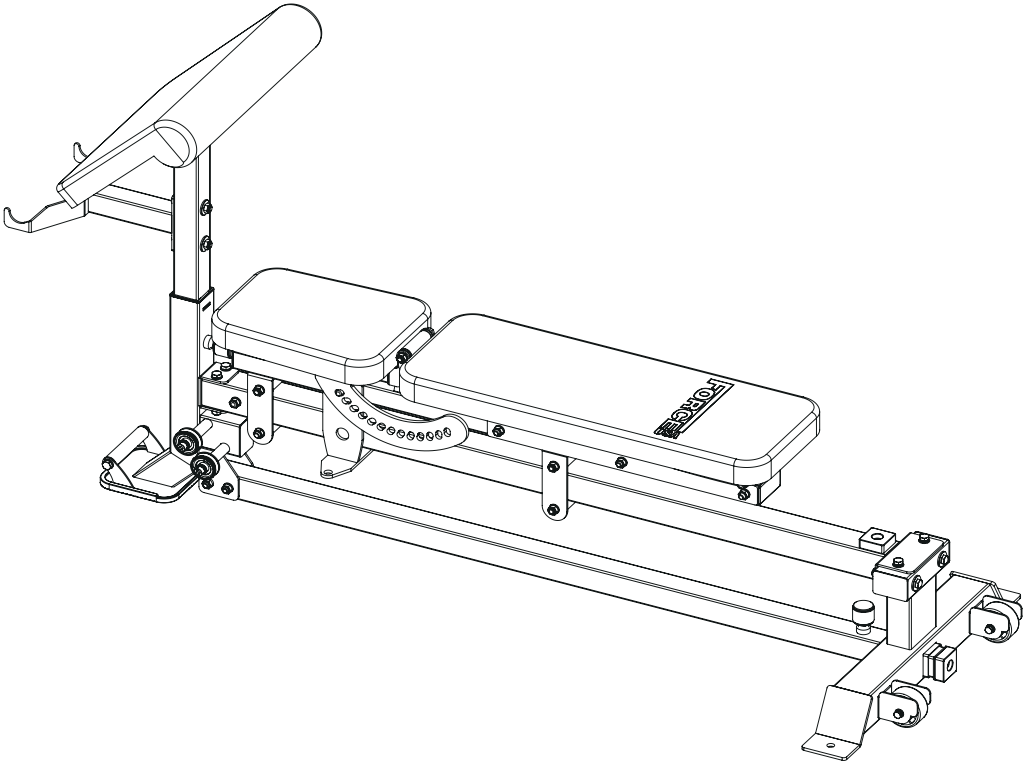

ASSEMBLY STEP 13

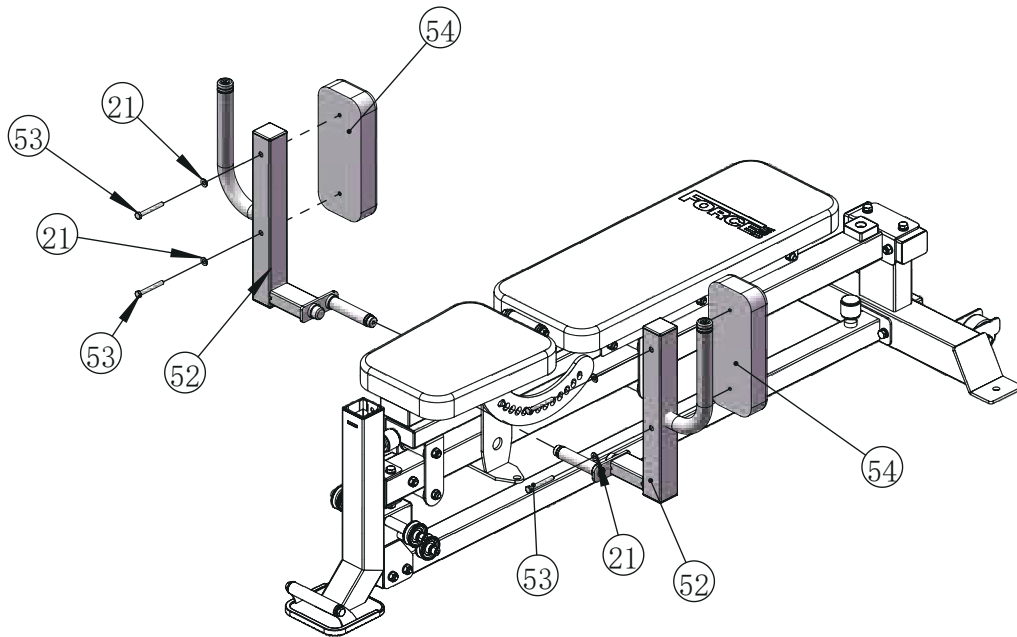

Key No.	Description	Note	Quantity
21	Washer	$\phi 8$	4
52	Shoulder Pad Frame		2
53	Hexagon Head Bolt	M8×65	4
54	Shoulder Pad		2

ASSEMBLY STEP 14

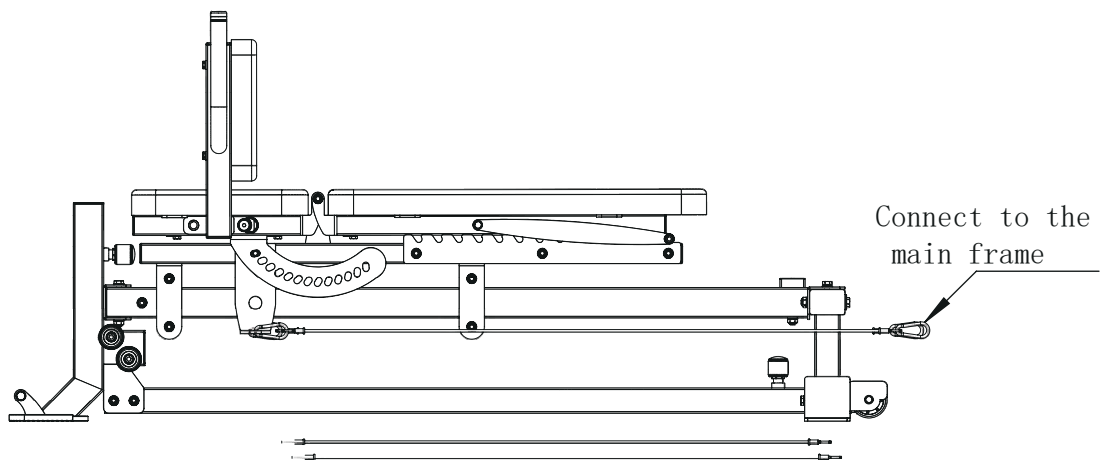
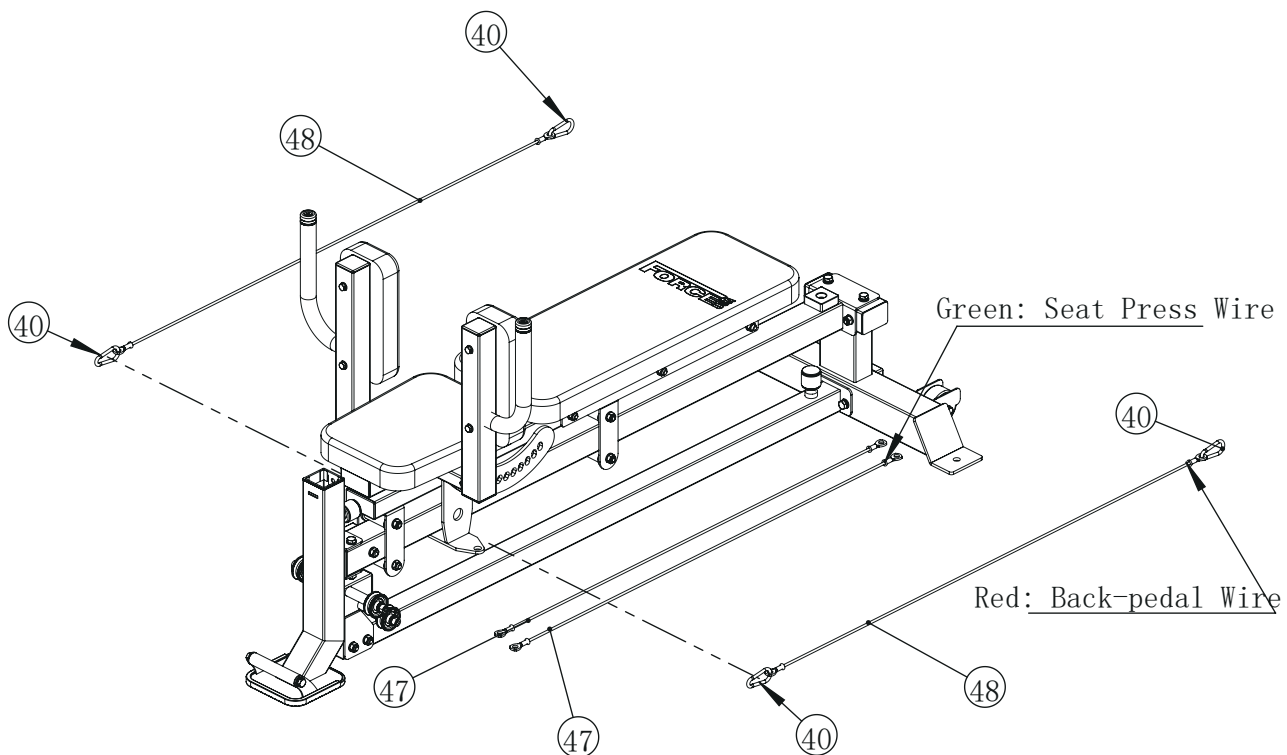

Key No.	Description	Note	Quantity
40	Carabiner		4
47	Leg Press Hack Squat Cable - Green		2
48	Leg Press Hack Squat Cable - Red		2

ASSEMBLY STEP 15

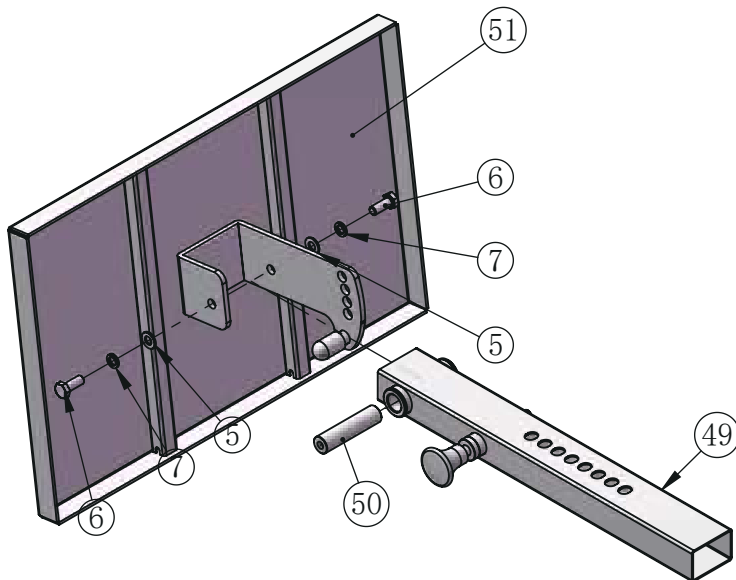
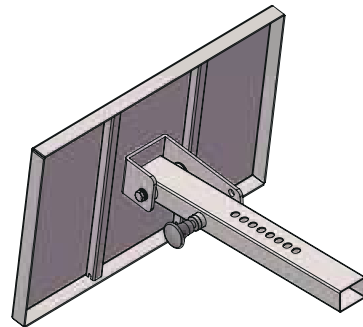

Key No.	Description	Note	Quantity
5	Washer	$\phi 10$	2
6	Hexagon Head Bolt	M10 \times 25	2
7	Spring Washer	$\phi 10$	2
49	Leg Press Hack Squat Plate Adjustment Frame		1
50	Inner Shaft	$\phi 20 \times 82$ -M10	1
51	Leg Press Hack Squat Plate		1

ASSEMBLY DRAWING

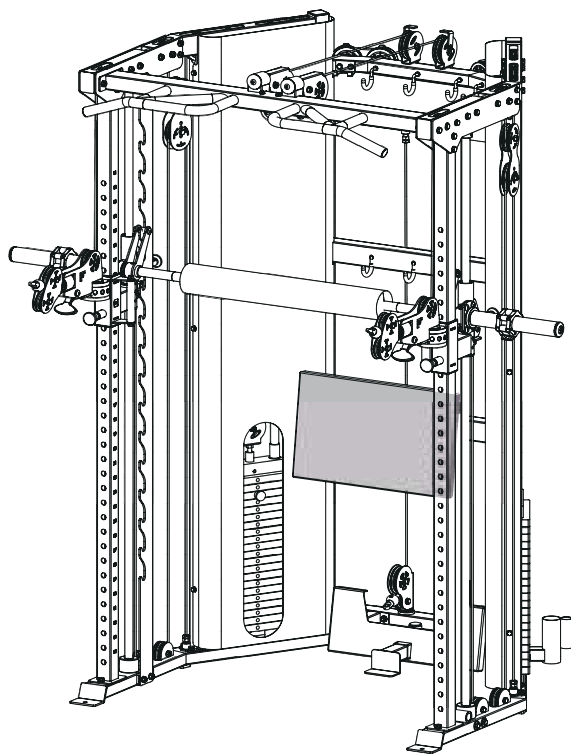
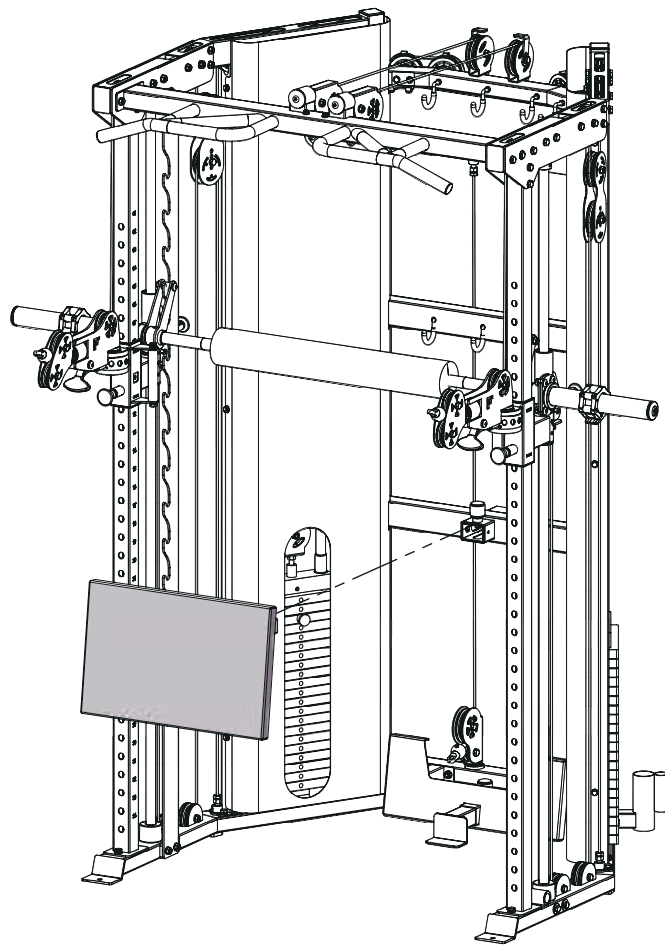

Back Pedal Training Main Frame Connection

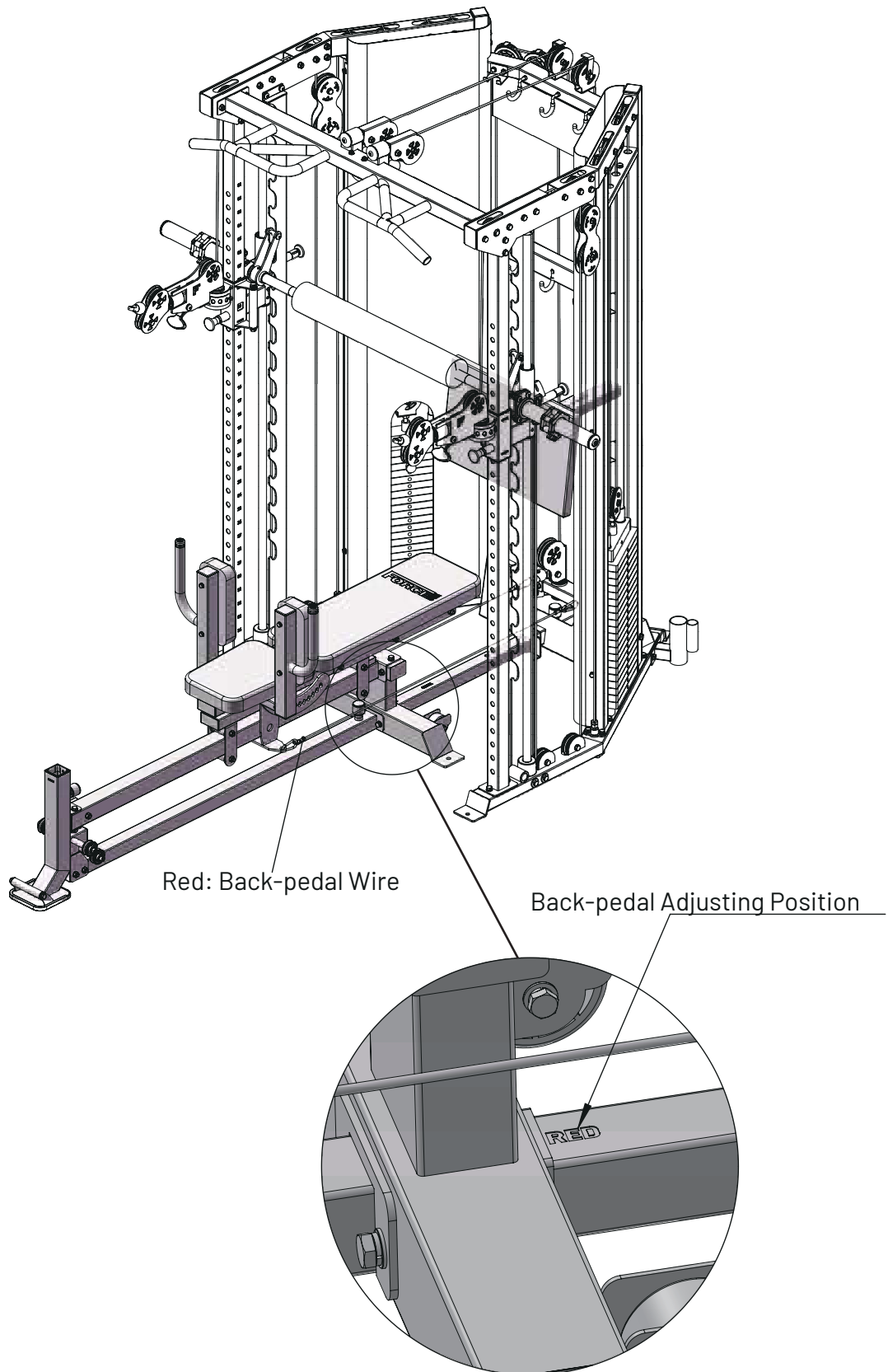

Seat Pedal Training Main Frame Connection

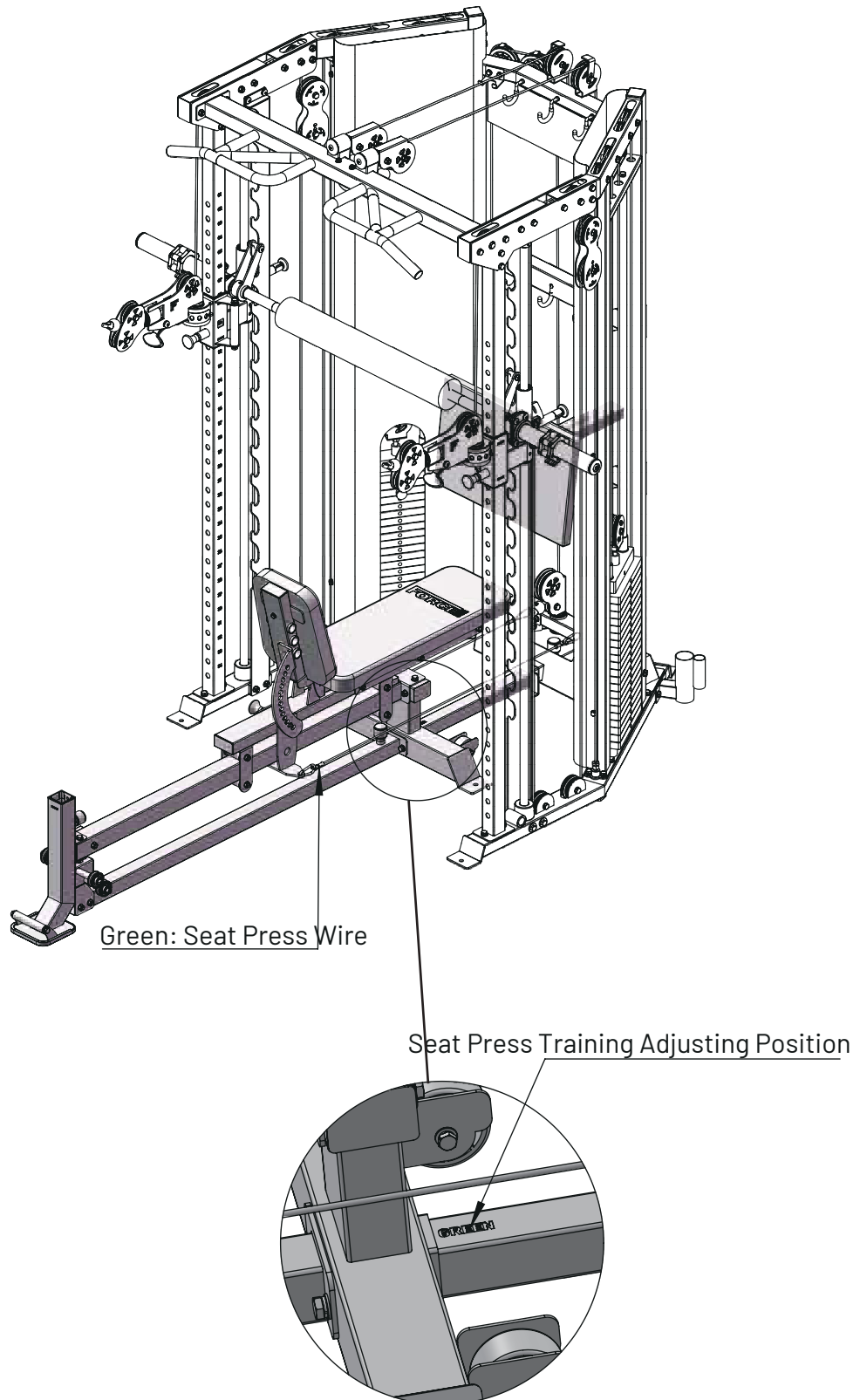

EXPLODED DIAGRAM

1. Main Beam Tube, 1 pc

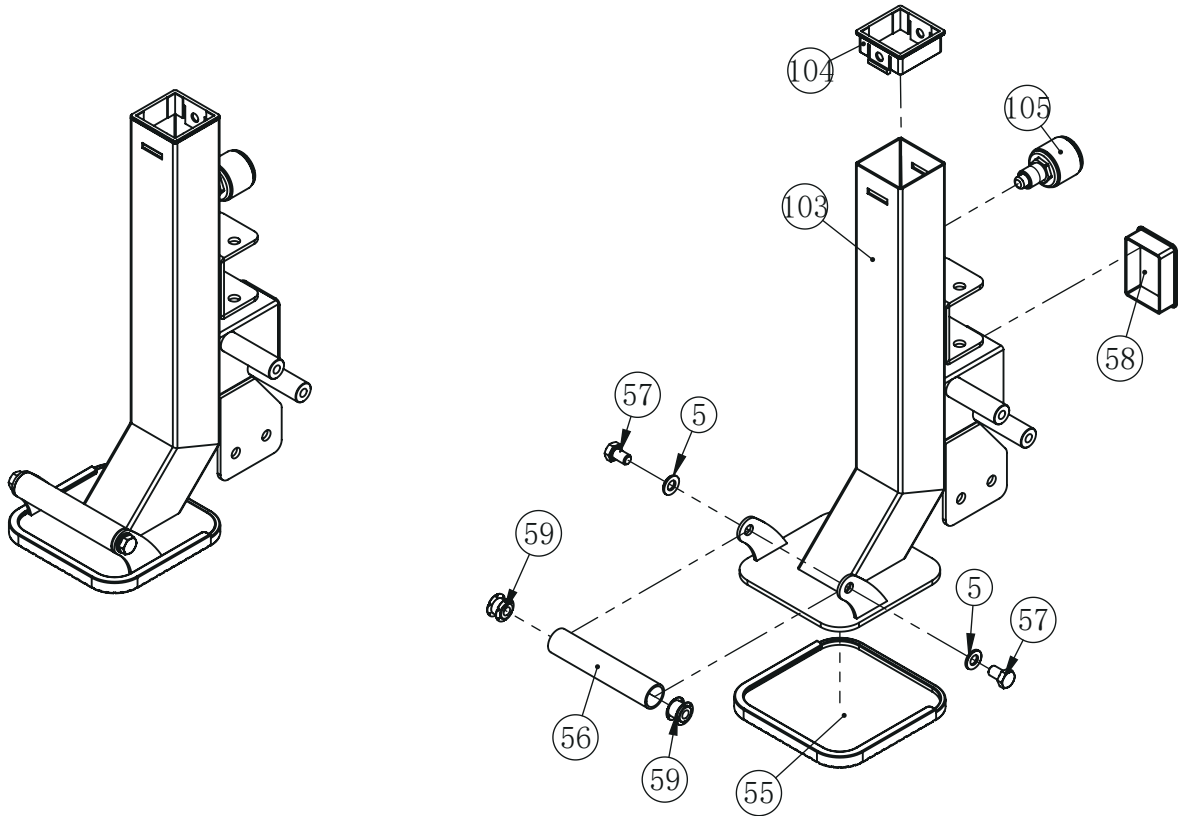

Key No.	Description	Note	Quantity
5	Washer	$\phi 10$	2
55	Foot Pad	F150	1
56	Movable Handle	$\phi 25 \times 1.5$	1
57	Hexagon Head Bolt	M10 \times 16	2
58	Inner Plug	50*70*2	1
59	Two Layer Spring Slice Nut	$\phi 23$ -M10	2
103	Front Stand Tube		1
104	Bushing	50-60	1
105	Plum Pin	$\phi 12$	1

EXPLODED DIAGRAM

2. Adjusting Outer Tube, 1 pc

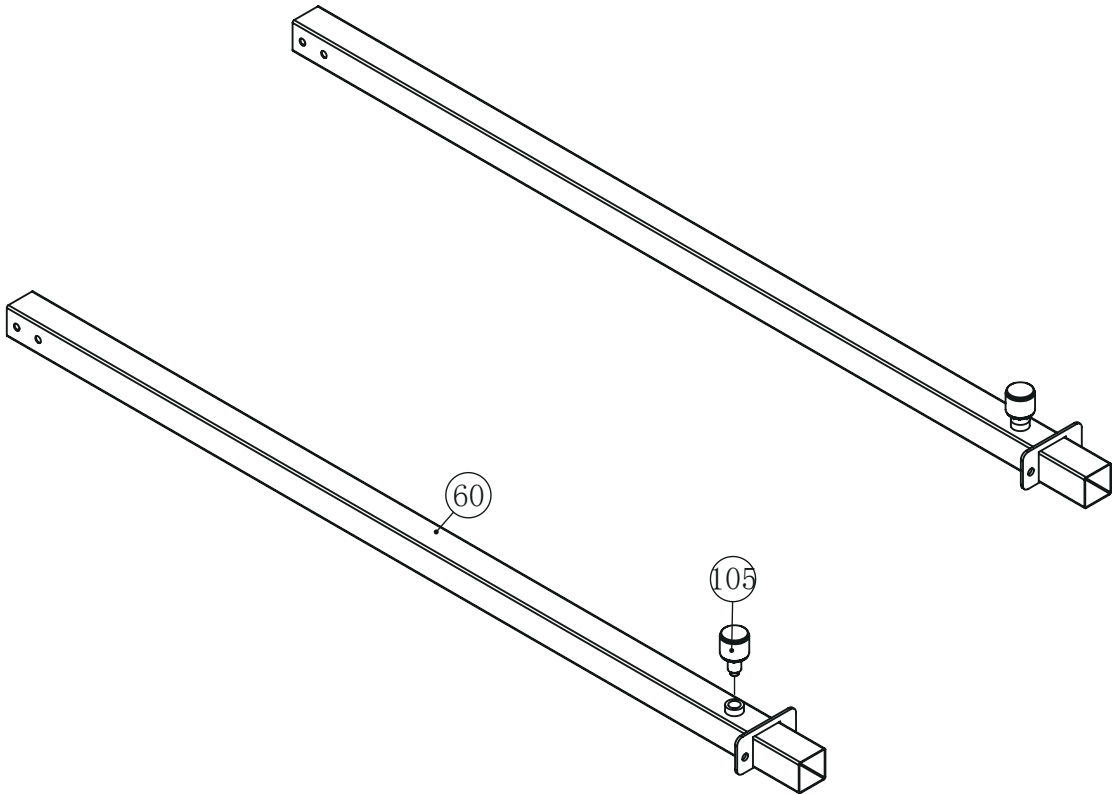

Key No.	Description	Note	Quantity
60	Adjusting Outer Tube		1
105	Plum Pin	φ12	1

EXPLODED DIAGRAM

8. Rear Base Beam, 1 pc

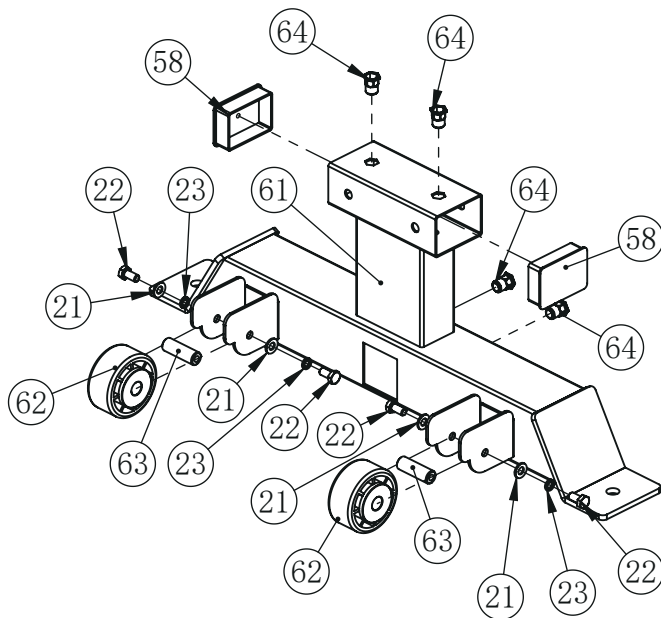
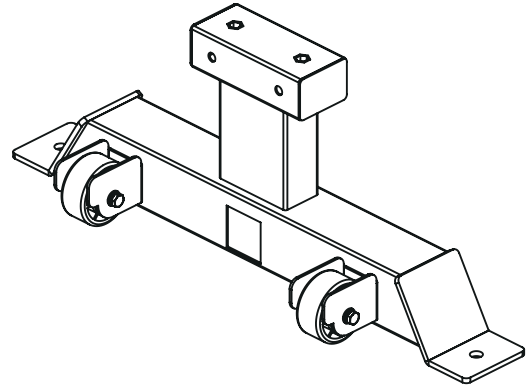

Key No.	Description	Note	Quantity
21	Washer	φ8	4
22	Hexagon Head Bolt	M8×16	4
23	Washer	φ8	4
58	Inner Plug	50*70*2	2
61	Rear Base Beam		1
62	PU Movable Roller	φ70 with Bearing	2
63	Roller Shaft	φ14.9×45-M8	2
64	Sunk Head Hexagon Rivet Nut	M10	4

EXPLODED DIAGRAM

9. Supporting Tube, 1 pc

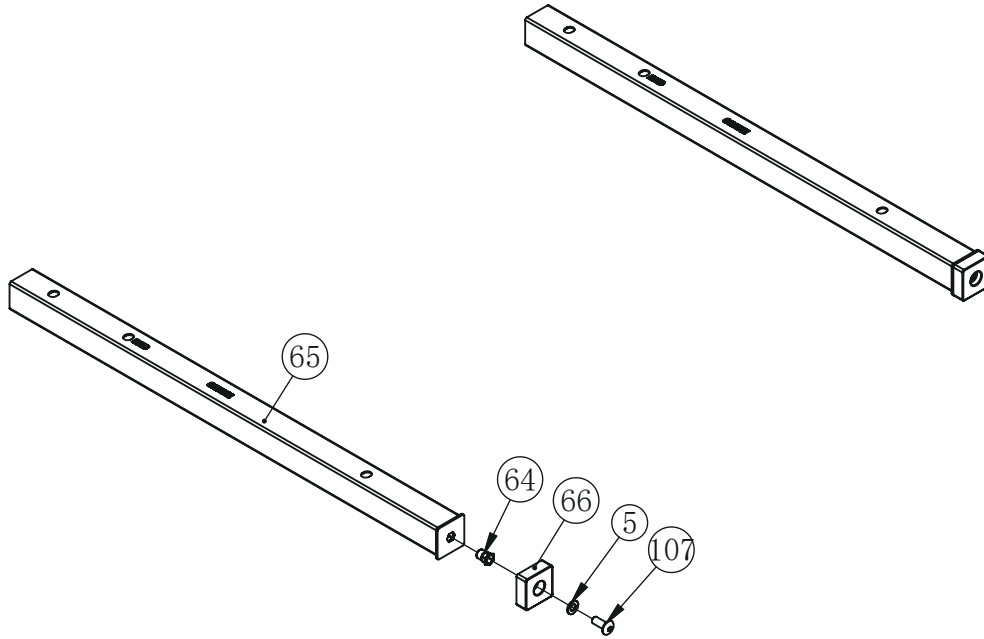

Key No.	Description	Note	Quantity
5	Washer	$\phi 10$	1
65	Supporting Tube		1
66	Square Shock Pad	$\square 50 \times 50 \times 18$	1
64	Sunk Head Hexagon Rivet Nut	M10	1
107	Inner Hexagon Flat Round Head Bolt	M10 \times 25	1

EXPLODED DIAGRAM

10. Sliding Sleeve, 1 pc

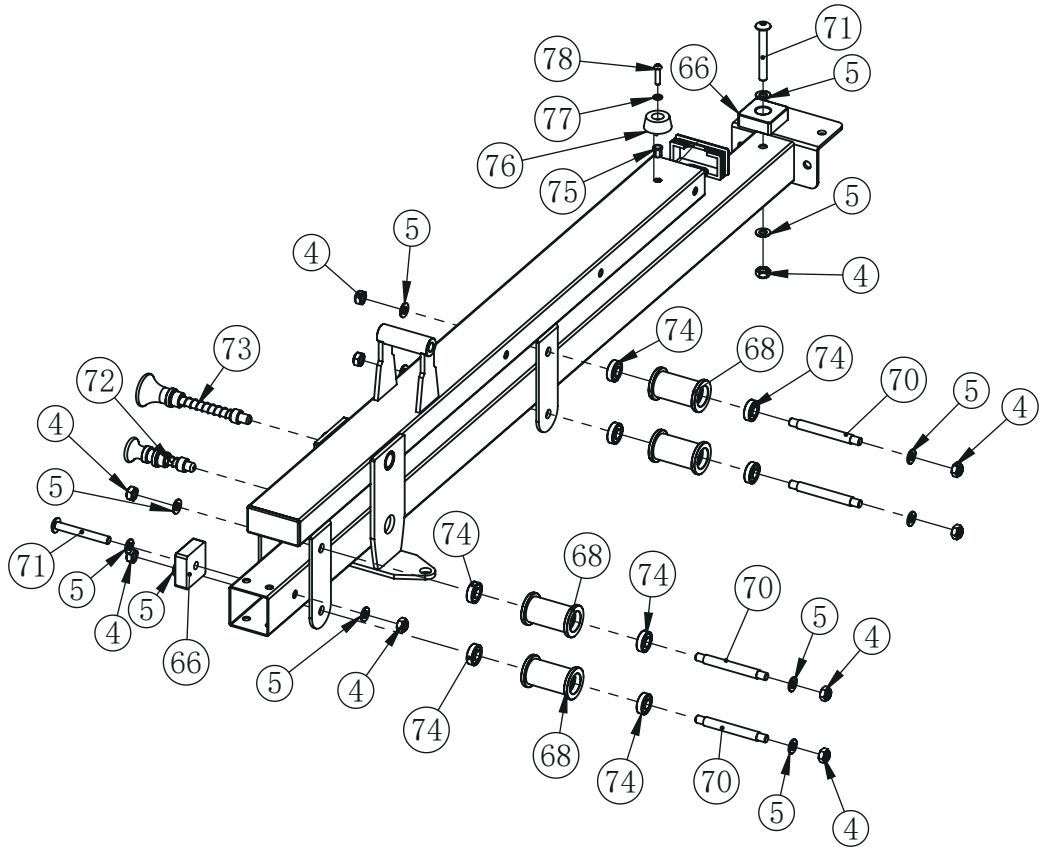

Key No.	Description	Note	Quantity
4	Lock Nut	M10	10
5	Washer	φ10	12
66	Square Shock Pad	□50×50×18	2
67	Rail Tube		1
68	60 Tube Roller	φ44×70.5	4
69	Square Tube Inner Plug	□40×80×2	2
70	Double Head Bolt	φ12×107-M10	4
71	Inner Hexagon Flat Round Head Bolt	M10×80	2
72	Umbrella Orientation Pin	φ12×M20×40	1
73	Umbrella Pin	φ12×M20×100	1
74	Deep Groove Ball Bearing	6001	8
75	Hexagon Rivet Nut	M6	1
76	Cone Shock Pad	φ37×φ31×φ7×16	1
77	Flat Gasket	φ6	1
78	Inner Hexagon Flat Round Head Bolt	M6×25	1
102	Sliding Sleeve		1

EXPLODED DIAGRAM

16. Back Pad Tube, 1 pc

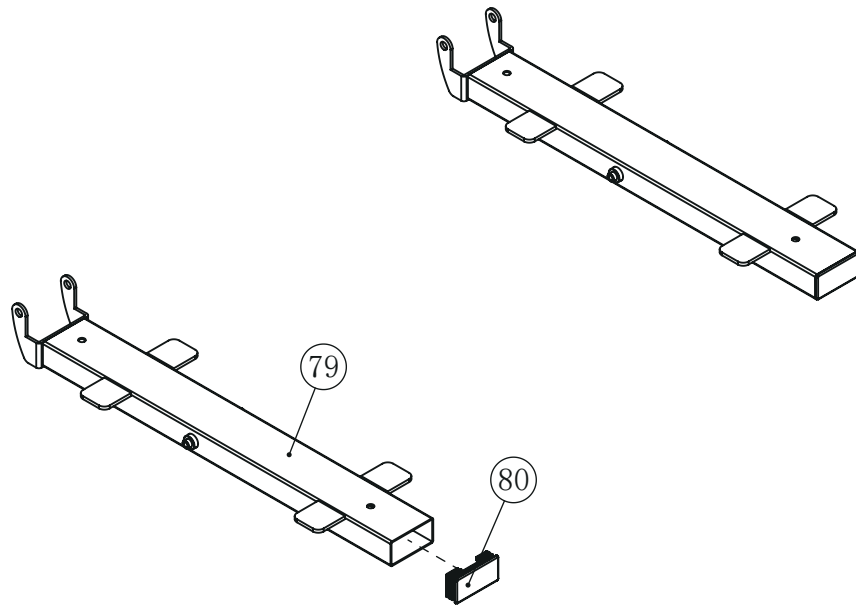

Key No.	Description	Note	Quantity
79	Back Pad Tube		1
80	Square Tube Inner Plug	□40×80×2	1

EXPLODED DIAGRAM

18. Seat Tube, 1 pc

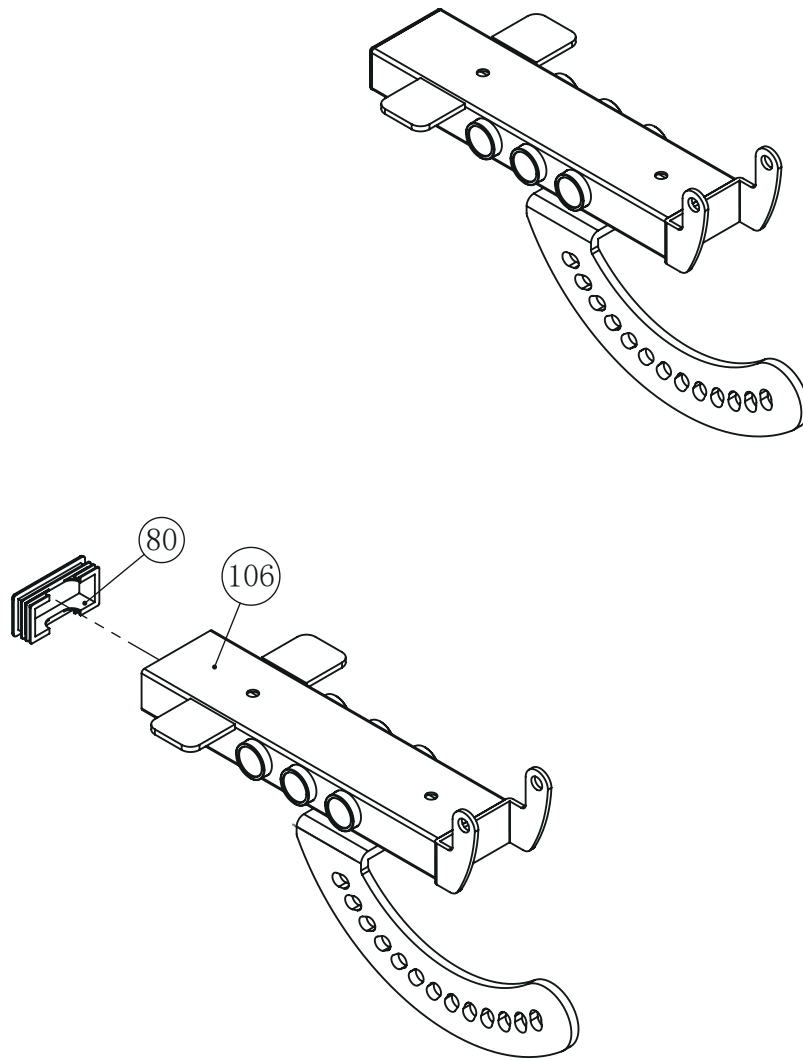

Key No.	Description	Note	Quantity
80	Square Tube Inner Plug	□40×80×2	1
106	Seat Tube		1

EXPLODED DIAGRAM

30. Leg Curl Inner Insert Tube, 1 pc

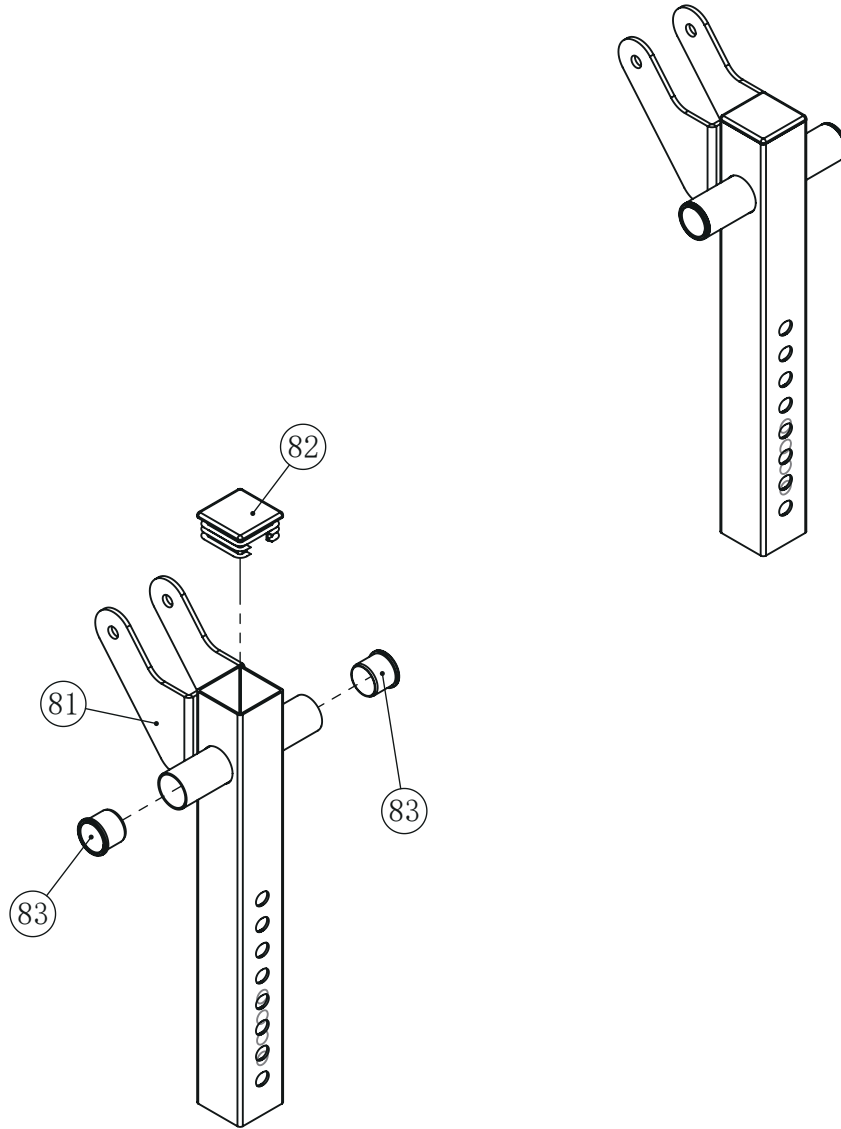

Key No.	Description	Note	Quantity
81	Leg Curl Inner Insert Tube		1
82	Square Tube Inner Plug	□50×50×2	1
83	Round Reduction Sleeve	φ32×φ26×25	2

EXPLODED DIAGRAM

31. Leg Curl Frame, 1 pc

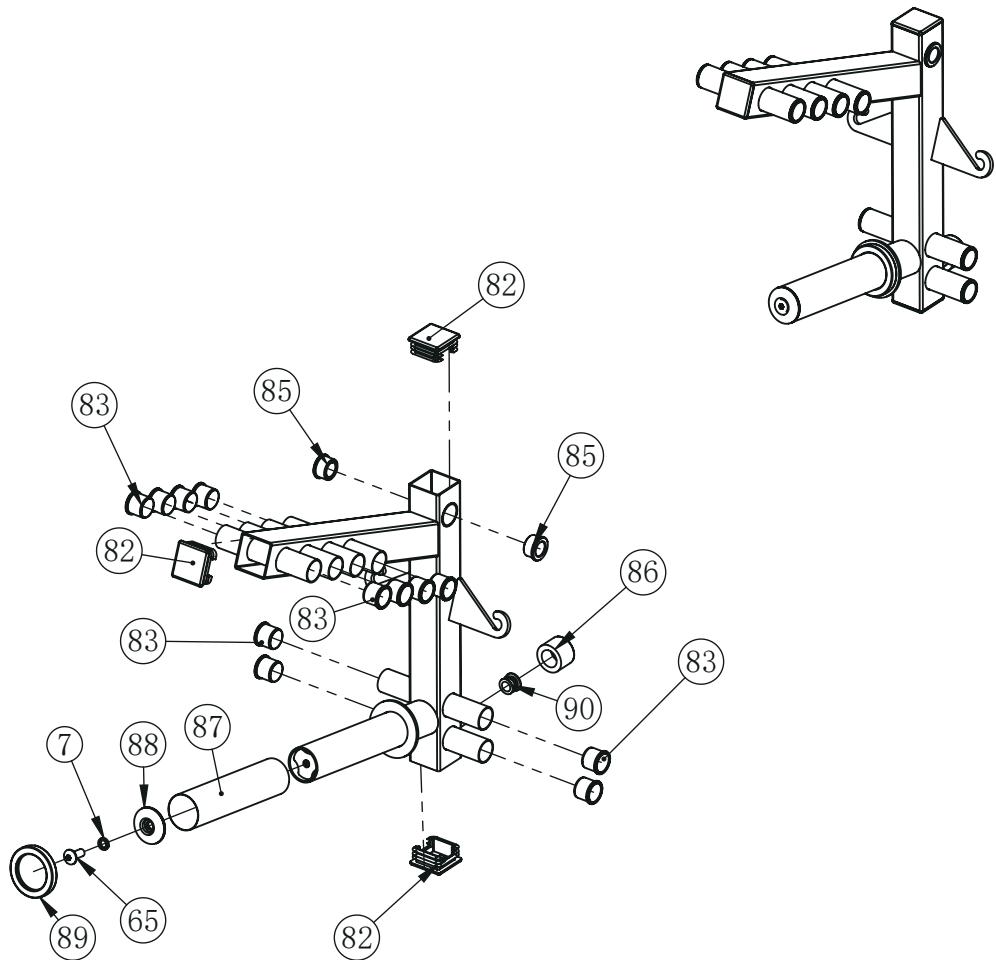

Key No.	Description	Note	Quantity
7	Spring Washer	$\phi 10$	1
65	Supporting Tube		1
82	Square Tube Inner Plug	$\square 50 \times 50 \times 2$	3
83	Round Reduction Sleeve	$\phi 32 \times \phi 26 \times 25$	12
84	Leg Curl Frame		1
85	Powder Sleeve	$\phi 33 \times \phi 29 \times \phi 20 \times 18$	2
86	Rubber Round Pad	$\phi 40 * \phi 25 * \phi 11 * 29$	1
87	Outer Sleeve Tube	$\phi 49.5 * 0.6 * 200$	1
88	Decorative Aluminium Cover	$\phi 11 \times \phi 18 \times \phi 42 \times \phi 50$	1
89	Rubber Closing Ring	$\phi 70 \times \phi 50 \times \phi 10$	1
90	Round Tube Inner Plug	$\phi 25 \times 2$	1

EXPLODED DIAGRAM

33. Foam Roller Support Rod, 3 pcs

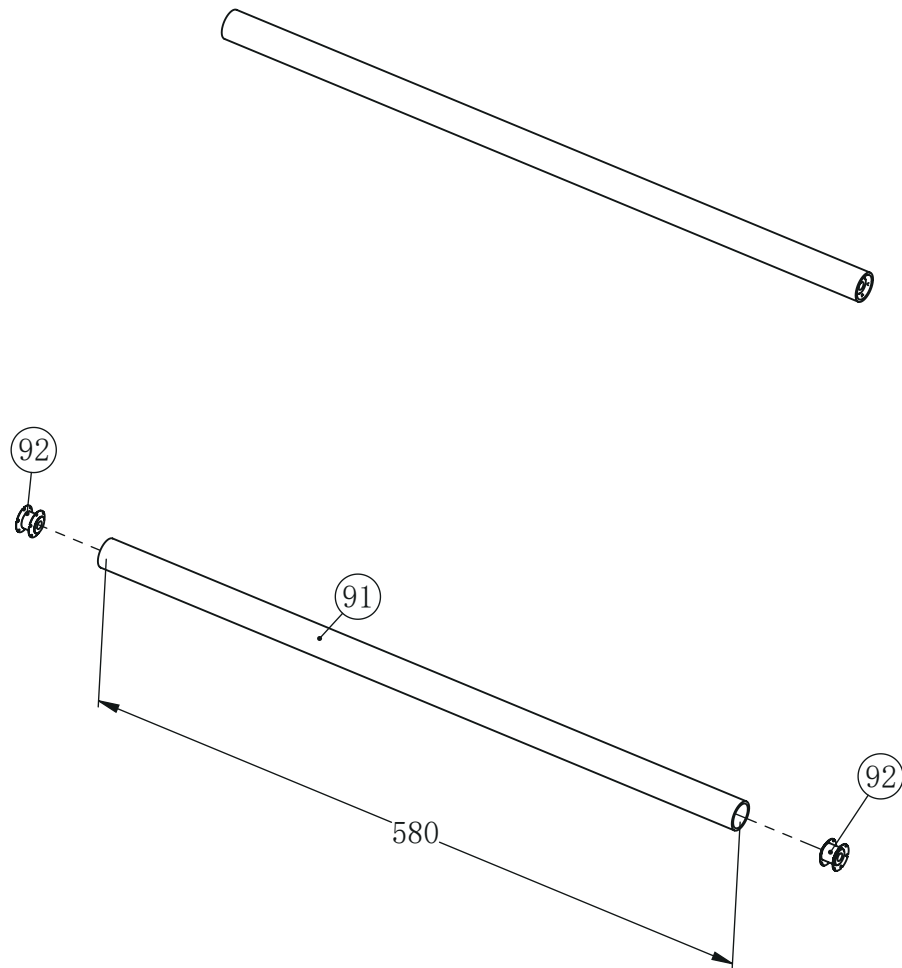

Key No.	Description	Note	Quantity
91	Foam Tube 580	$\phi 25 \times 2$	1
92	Two Layer Spring Slice Nut	$\phi 23 - M8$	2

EXPLODED DIAGRAM

49. Leg Curl Adjusting Tube, 1 pc

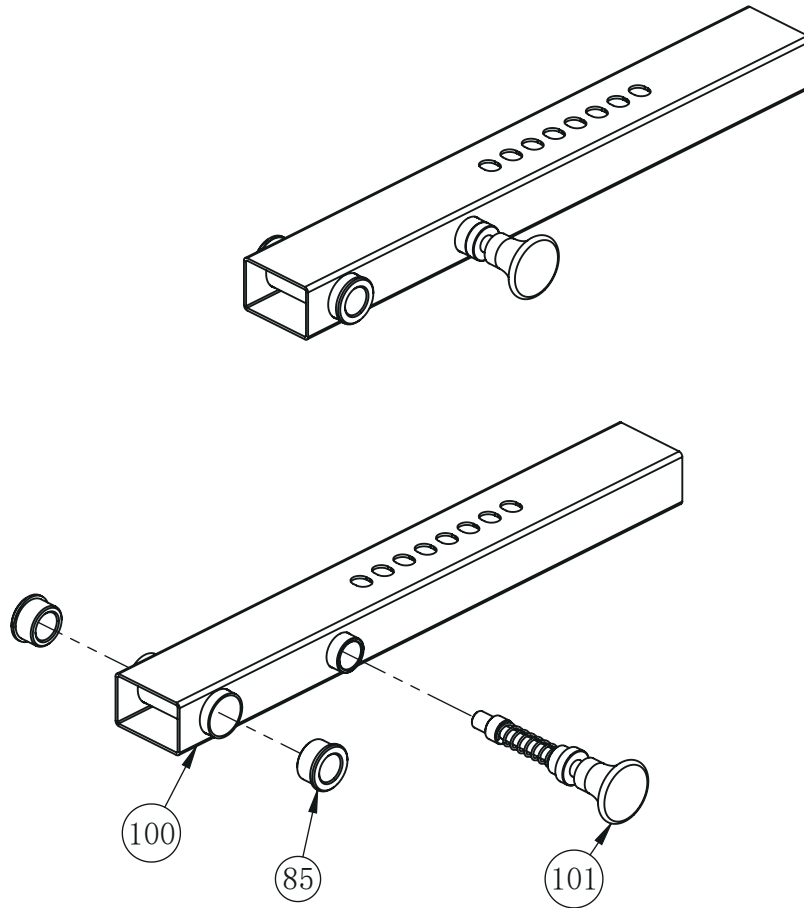

Key No.	Description	Note	Quantity
85	Powder Sleeve		2
100	Leg Curl Adjusting Tube	$\phi 33 \times \phi 29 \times \phi 20 \times 18$	1
101	Umbrella Pin	$\phi 12 \times M20 \times 75$	1

EXPLODED DIAGRAM

51. Foot Pedal Rotator, 1 pc

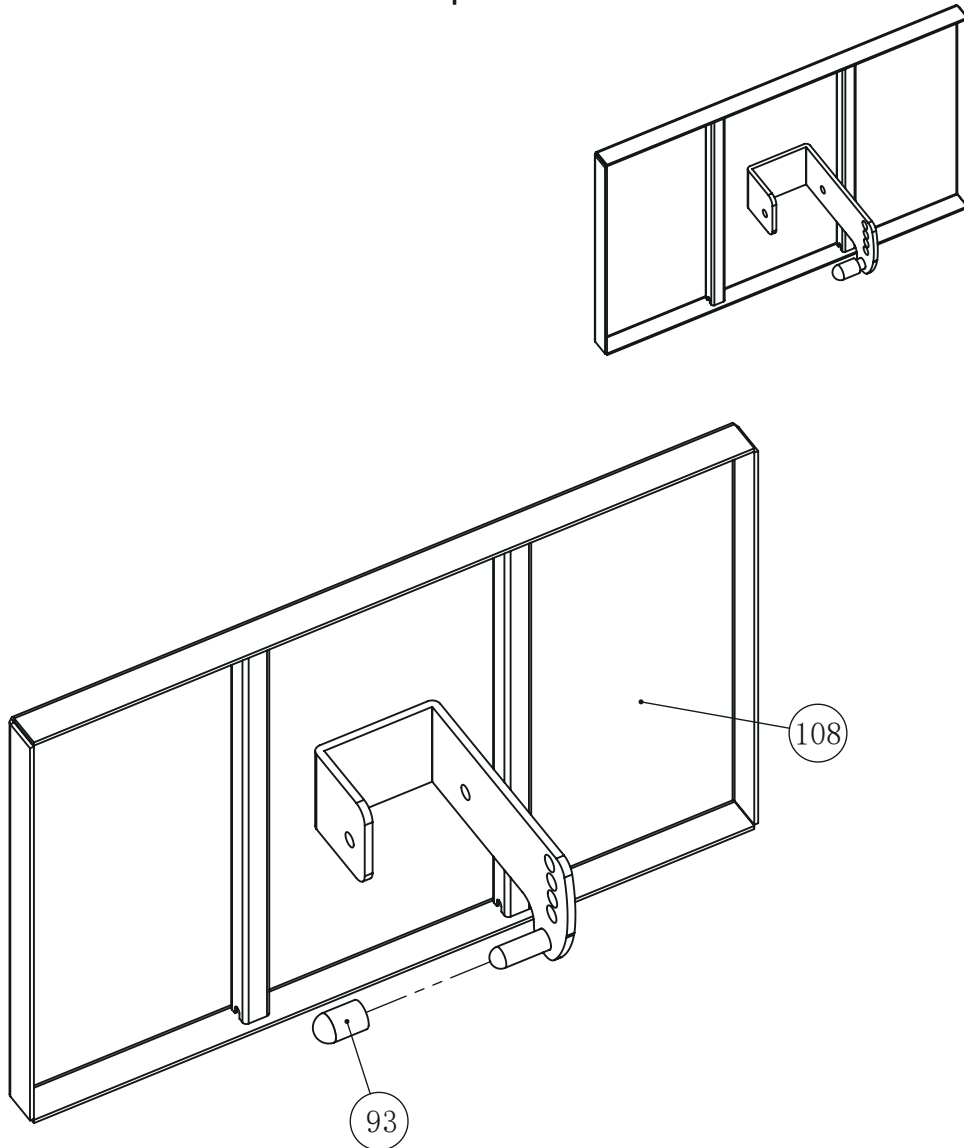

Key No.	Description	Note	Quantity
93	Buffer Sleeve	$\phi 21*35$	1
108	Seated Row Foot Plate		1

EXPLODED DIAGRAM

52. Shoulder Pad, 2 pc

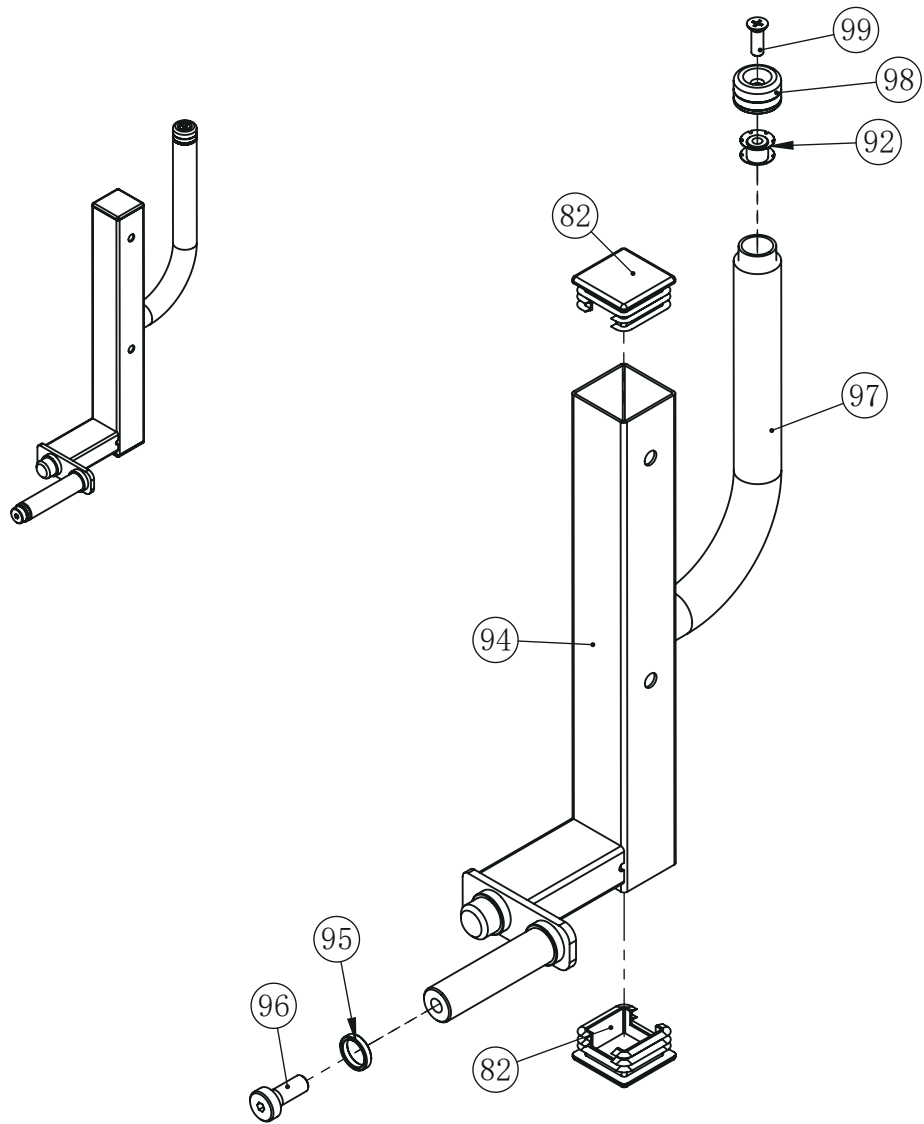

Key No.	Description	Note	Quantity
82	Square Tube Inner Plug	□50×50×2	2
92	Two Layer Spring Slice Nut	φ23-M8	1
94	Shoulder Pad		1
95	Limit Ring	φ25*φ20*5	1
96	Barbell Bar Limit Shaft	φ22*39.5	1
97	Upper Handgrip Sleeve	φ25*310	1
98	Handgrip Outer Stop Collar	φ31.5×φ25.5	1
99	Sunk Head Cross Groove Screw	M8×20	1

PARTS LIST

Key No.	Description	Note	Quantity
1	Main Beam Tube		1
2	Adjusting Outer Tube		1
3	Hexagon Head Bolt	M10×75	2
4	Lock Nut	M10	25
5	Flat Gasket	φ10	50
6	Hexagon Head Bolt	M10×25	8
7	Spring Gasket	φ10	13
8	Rear Base Beam		1
9	Supporting Tube		1
10	Sliding Sleeve		1
11	Large Flat Gasket	φ10	4
12	Hexagon Head Bolt	M10×90	2
13	Hexagon Head Bolt	M10×85	2
14	Gear Adjusting Plate	T4	2
15	Hexagon Head Bolt	M10×105	3
16	Back Pad Tube		1
17	Outer Wire Shaft	φ12*M10*118	1
18	Seat Tube		1
19	Back Pad Adjusting Plate	T6	2
20	Double Head Bolt	φ12×130-M10	1
21	Flat Gasket	φ8	18
22	Hexagon Head Bolt	M8×16	6
23	Spring Gasket	φ8	6
24	Back Pad		1
25	Seat Pad		1
26	Hexagon Head Bolt	M8×60	4
27	Pulley	φ50	4
28	Inner Hexagon Column Head Bolt	M10×50	4
29	Inner Wire Shaft	φ20×57-M10	1
30	Leg Curl Inner Insert Tube		1
31	Leg Curl Frame		1
32	Cable Catch Wheel	φ78×φ26×28	2
33	Foam Roller Support Rod		3
34	Foam Roller	φ25Xφ100X200	4
35	Foam Inner Stopper Cover (Chromed)	φ70×φ27×12	4
36	Foam Outer Stopper Cover (Chromed)	φ70×φ9×14	6
37	Foam	φ25Xφ100X175	2

PARTS LIST

Key No.	Description	Note	Quantity
38	Hexagon Socket Button Head Screw	M8×25	6
39	Spring Collar	φ50	1
40	Carabiner		8
41	Leg Curl Wire		2
42	Chest Pad Tube		1
43	Barbell Support Tube		1
44	Chest Pad		1
45	Hexagon Head Bolt	M10×70	2
46	Hexagon Head Bolt	M8×20	4
47	Seat Pedal Wire		2
48	Back Pedal Wire		2
49	Leg Curl Adjusting Tube		1
50	Inner Shaft	φ20*82-M10	1
51	Foot Pedal Rotator		1
52	Shoulder Pad Weldment		2
53	Hexagon Head Bolt	M8×65	4
54	Shoulder Pad		2
55	Foot Pad	F150	1
56	Movable Handle	φ25*1.5	1
57	Hexagon Head Bolt	M10×16	2
58	Inner Plug	50*70*2	3
59	Two Layer Spring Slice Nut	φ23-M10	2
60	Adjusting Outer Tube		1
61	Rear Base Beam		1
62	PU Movable Roller	φ70 with Bearing	2
63	Roller Shaft	φ14.9×45-M8	2
64	Sunk Head Hexagon Rivet Nut	M10	5
65	Supporting Tube		1
66	Square Shock Pad	□50×50×18	3
67	Rail Tube		1
68	60 Tube Roller	φ44×70.5	4
69	Square Tube Inner Plug	□40×80×2	2
70	Double Head Bolt	φ12×107-M10	4
71	Inner Hexagon Flat Round Head Bolt	M10×80	2
72	Umbrella Orientation Pin	φ12×M20×40	1
73	Umbrella Pin	φ12×M20×100	1

PARTS LIST

Key No.	Description	Note	Quantity
74	Deep Groove Ball Bearing	6001	8
75	Hexagon Rivet Nut	M6	1
76	Cone Shock Pad	$\phi 37 \times \phi 31 \times \phi 7 \times 16$	1
77	Flat Gasket	$\phi 6$	1
78	Inner Hexagon Flat Round Head Bolt	M6 \times 25	1
79	Back Pad Tube		1
80	Square Tube Inner Plug	$\square 40 \times 80 \times 2$	2
81	Leg Curl Inner Insert Tube		1
82	Square Tube Inner Plug	$\square 50 \times 50 \times 2$	8
83	Round Reduction Sleeve	$\phi 32 \times \phi 26 \times 25$	14
84	Leg Curl Frame		1
85	Powder Sleeve	$\phi 33 \times \phi 29 \times \phi 20 \times 18$	4
86	Rubber Round Pad	$\phi 40 * \phi 25 * \phi 11 * 29$	1
87	Outer Sleeve Tube	$\phi 49.5 * 0.6 * 200$	1
88	Decorative Aluminium Cover	$\phi 11 \times \phi 18 \times \phi 42 \times \phi 50$	1
89	Rubber Closing Ring	$\phi 70 \times \phi 50 \times \phi 10$	1
90	Round Tube Inner Plug	$\phi 25 \times 2$	1
91	Foam Tube 580	$\phi 25 * 2$	1
92	Two Layer Spring Slice Nut	$\phi 23 - M8$	8
93	Buffer Sleeve	$\phi 21 * 35$	1
94	Shoulder Pad		2
95	Limit Ring	$\phi 25 * \phi 20 * 5$	2
96	Barbell Bar Limit Shaft	$\phi 22 * 39.5$	2
97	Upper Handgrip Sleeve	$\phi 25 * 310$	2
98	Handgrip Outer Stop Collar	$\phi 31.5 \times \phi 25.5$	2
99	Sunk Head Cross Groove Screw	M8 \times 20	2
100	Leg Curl Adjusting Tube		1
101	Umbrella Pin	$\phi 12 \times M20 \times 75$	1
102	Sliding Sleeve		1
103	Front Stand Tube		1
104	Bushing	50-60	1
105	Plum Pin	$\phi 12$	2
106	Seat Tube		1
107	Hexagon Socket Button Head Screw	M10 \times 25	2
108	Seated Row Foot Plate		1

MEASURING FOR BOLT LENGTH





We believe success comes from striving to be better than yesterday. It comes from the urge to push boundaries and break through barriers. Fueled with the belief that everybody deserves a fit and healthy lifestyle, we are dedicated to providing innovative strength and fitness solutions to build stronger, happier and healthier lives.

WARRANTY

The Force USA range of strength equipment carries a Lifetime (10 Year) Structural Warranty along with two years cover on all moving parts and 90 days warranty on all upholstery items. This warranty applies to first owners and does not cover second-hand equipment or re-sold equipment. This Force USA warranty covers only failures due to defects in structural elements, cables and pulleys and workmanship that occur during regular use in the warranted environment. It will not cover damage that occurs in transport/delivery or failure due to misuse, abuse, neglect, misapplication, alteration or improper assembly of the product. The replacement or repair provided for under the Force USA warranty is the responsibility of the user, and the customer will be responsible for any freight charges that apply. Force USA will not be liable for any consequential damages or breach of any implied warranty on the range of Force USA strength equipment. Force USA reserves the right to provide reconditioned parts and/or to request a return and repair existing defective components on the Force USA product.