

FORCE USA

C10 BASE BENCH

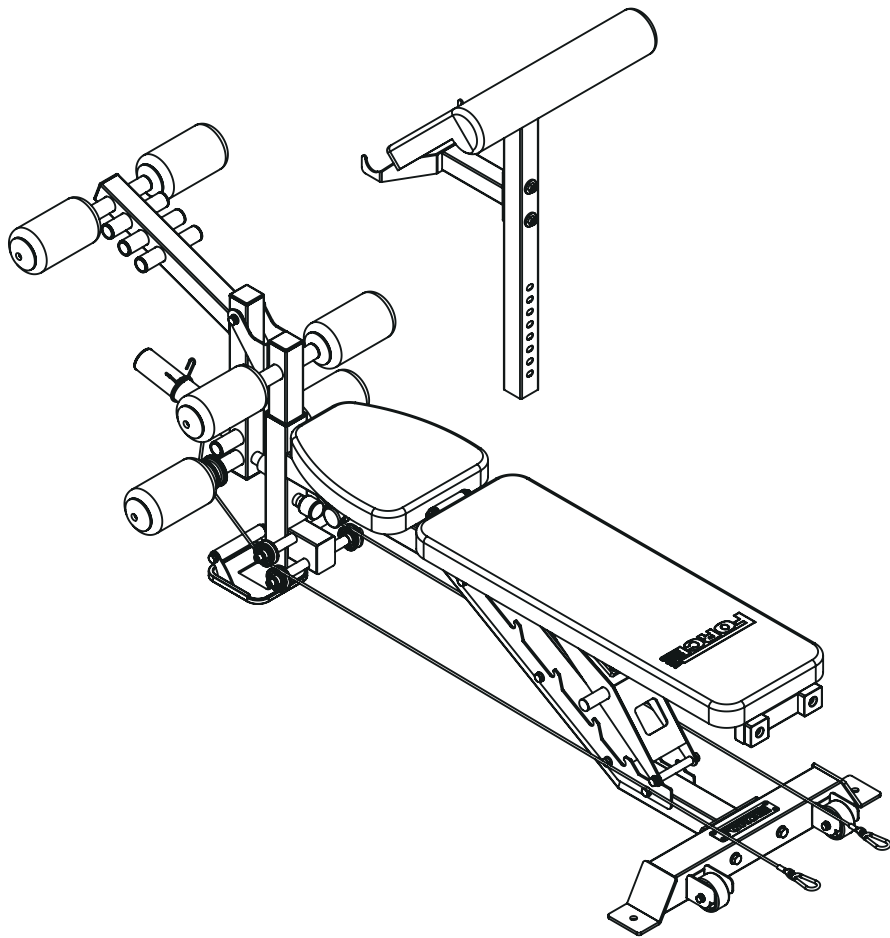

TABLE OF CONTENTS

SECTION	PAGES
Before you Start and Safety Information	2
ForceUSA App	3
Preventative Maintenance	4
Parts Identification.....	5-9
Assembly Steps	10-19
Exploded Diagrams	21-28
Parts Lists	29-31
Warranty Information	32

USER MANUAL

Before You Start

- Read all instructions in this manual before assembling or using this equipment
- Remove all parts from the packaging and count each component separately to ensure everything is provided correctly, noting that some items may be pre-assembled
- Follow the instructions and refer to both the individual assembly pages and the exploded views of the equipment whenever possible
- The owner is responsible for ensuring that all users of this unit have read the user manual and understand the safety precautions
- Descriptions of left and right refer to the perspective of standing in front of the equipment
- Place all parts in a cleared area and remove the packing materials. Do not dispose of the packing materials until all assembly steps are completed
- Machines with a counterbalanced smith bar require up to one meter of clearance above the assembled height to insert the counterbalances. If there is not enough clearance, insert the counterbalances into the required framing components before assembly and securely anchor off the cables to ensure they can be retrieved and attached as needed
- It is recommended to keep these instructions

Safety Precautions

- It is highly recommended that two or more people are used for assembly
- Assemble equipment on a flat surface
- Consider placing a mat/mats under the equipment to protect your floor
- Only tighten nuts and bolts loosely until all equipment is assembled. Once the equipment is fully assembled each bolt can be tightened working evenly around the equipment where possible
- Ensure all parts are in working order prior to use
- Make sure all pivoting components are able to move freely
- Do not use or store the equipment outdoors or around water
- Do not over tighten any component with pivoting function
- Keep hair, fingers and clothing away from moving parts
- Only use attachments recommended by the manufacturer
- Never operate if parts are not functioning correctly
- Always stretch prior to using equipment
- Stop immediately if you experience any pain, dizziness or nausea
- Before starting any exercise program consult your doctor

FORCE USA TRAINING APP

The Force USA training app offers programs, tutorials, progress tracking and more. Not compatible with all Force USA equipment.



PREVENTATIVE MAINTENANCE

To ensure your equipment is operating at its peak, please follow the below preventative maintenance schedule performing all tasks upon initial assembly:







Daily Maintenance

- Wipe down the equipment to remove any dust and sweat residue with a dry, non-abrasive cloth
- Inspect the unit for noisy, damaged or loose components

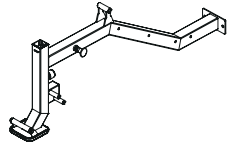
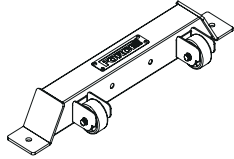

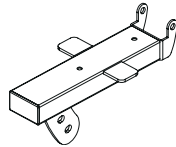
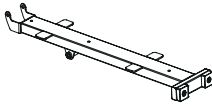
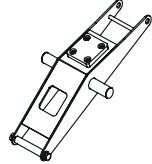
Monthly Maintenance

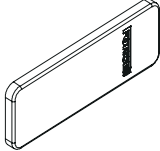
- Thoroughly clean the equipment using a non abrasive cloth dampened with a mild, all purpose cleaner ensuring to thoroughly wipe down and dry the equipment afterwards
- Apply a 100% silicone lubrication (preferably spray) to guide rods, pulley sliders, weight plate carriages and any other moving parts where friction can occur including bearings (where applicable). Any other form of lubrication will void your warranty
- Check the tightness of all bolts, nuts and screws
- Check the cables for fraying or any signs of wear and ensure they are at the correct tension with a small amount of slack at resting position (where applicable)
- Inspect pulleys for any damage or cracks (where applicable)
- Knurling can be cleaned using a soft bristled brush to help remove any particles that may be nestled within the knurling
- Vacuum around the machine/equipment to prevent dust acclimation

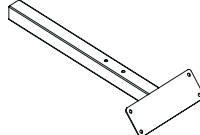

PARTS IDENTIFICATION

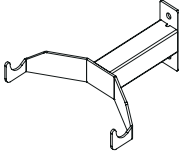
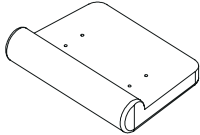
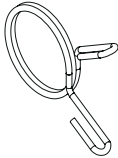
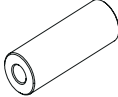
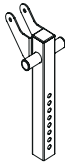
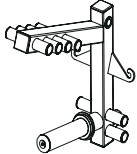
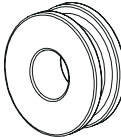
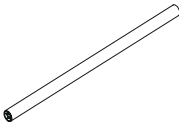
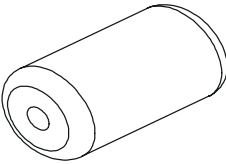
Key No.	Description	Quantity	Parts Schematic Diagram
1	Main Base Frame	1	
2	Rear Base Frame	1	
6	Adjustment Angle Locking Plate	2	
11	Seat Pad Frame	1	
12	Back Pad Frame	1	
13	Angle Adjustment Frame	1	
15	Seat Pad	1	
16	Back Pad	1	
21	Pulley	4	
22	Preacher Curl Frame	1	

PARTS IDENTIFICATION

Key No.	Description	Quantity	Parts Schematic Diagram
23	Preacher Curl Barbell Holder	1	
24	Preacher Curl Pad	1	
28	Spring Collar	1	
29	Leg Curl Extension Inner Shaft	1	
30	Leg Curl Extension Mounting Frame	1	
32	Leg Curl Extension Frame	1	
33	Pulley	4	
34	Foam Pad Rod	3	
35	Upper Foam Pad	4	
36	Foam Pad Inner Cover Plate	4	

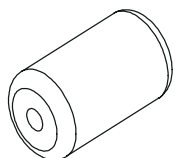
PARTS IDENTIFICATION

Key No.	Description	Quantity	Parts Schematic Diagram
37	Foam Pad Outer Cover Plate	6	
38	Lower Foam Pad	6	
40	Spring Collar	1	
41	Leg Curl Cable	1	

PARTS IDENTIFICATION

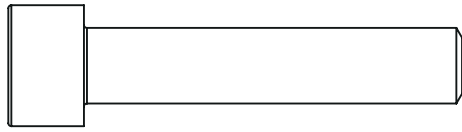

19. M10X50 (x4)

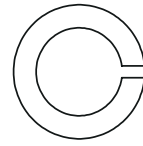

Spring Washer
20. ϕ 10 (x6)

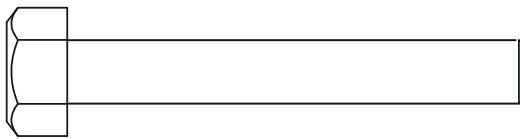

17. M8X60 (x5)

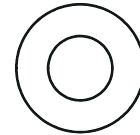

Washer
18. M10X50 (x4)



Double Thread Bolt
14. ϕ 12X129-M10 (x1)



Double Thread Bolt
10. 12X118-M10 (x1)

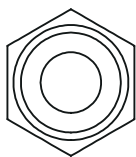

7. M10 (x10)

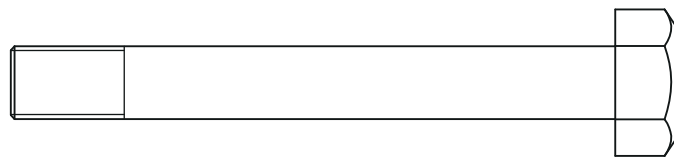

8. M10X80 (x4)

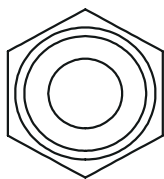

4. M12 (x2)

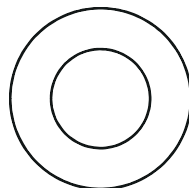

Washer
3. ϕ 12 (x4)

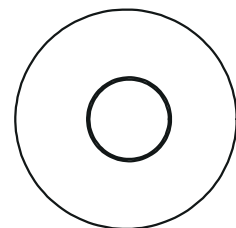

19. ϕ 30* ϕ 10.5*T3 (x2)

PARTS IDENTIFICATION

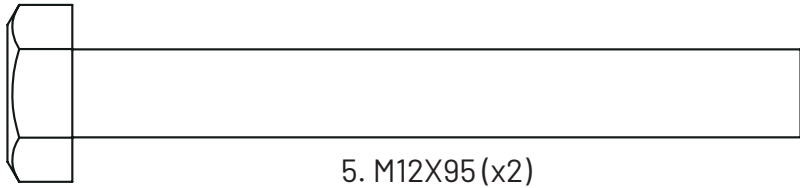

5. M12X95 (x2)



27. M10X70 (x2)

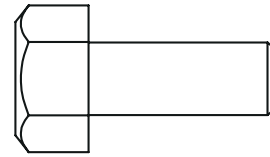

31. M110X25 (x2)

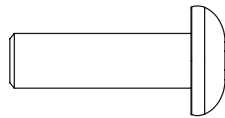

39. M8X25 (x6)

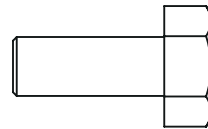

26. M8X20 (x4)

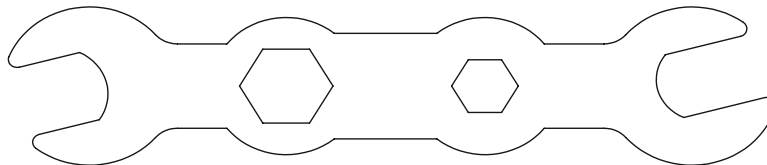

(x2)

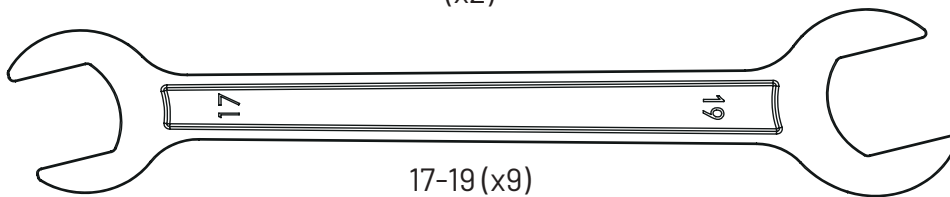

17-19 (x9)

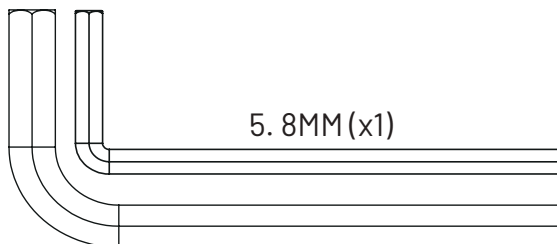

5. 8MM (x1)

ASSEMBLY STEP 1

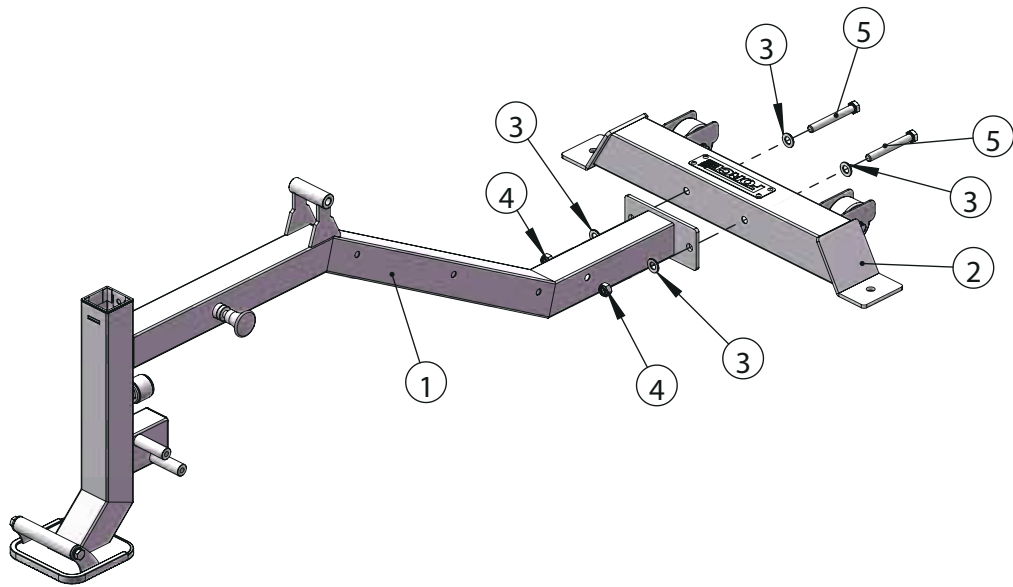

Key No.	Description	Note	Quantity
1	Main Base Frame		1
2	Rear Base Frame		1
3	Washer	φ12	4
4	Lock Nut	M12	2
5	Hexagon Head Bolt	M12×95	2

ASSEMBLY STEP 2

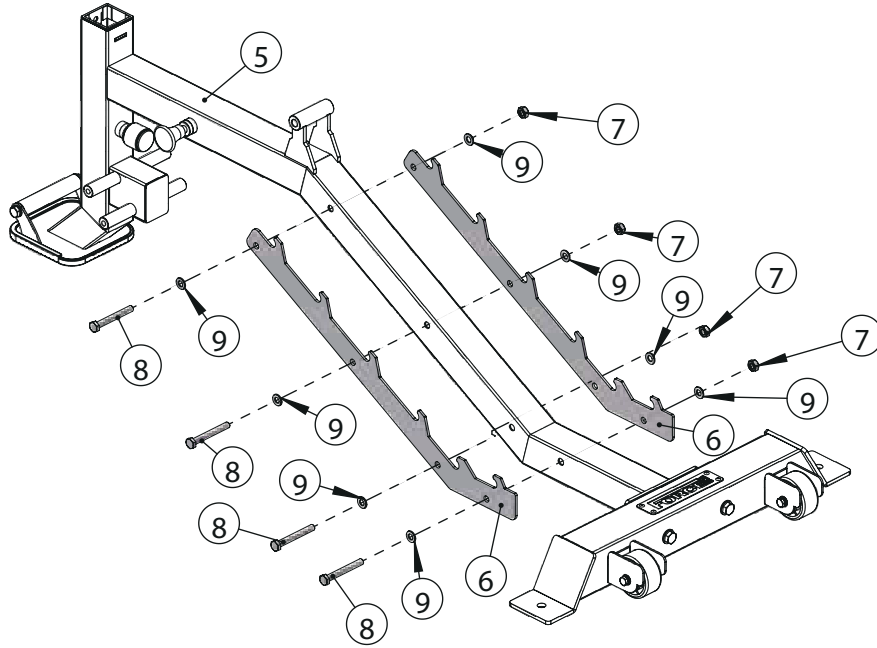

Key No.	Description	Note	Quantity
6	Adjustment Angle Locking Plate	T4	2
7	Lock Nut	M10	4
8	Hexagon Head Bolt	M10×80	4
9	Flat Gasket	φ10	8

ASSEMBLY STEP 3

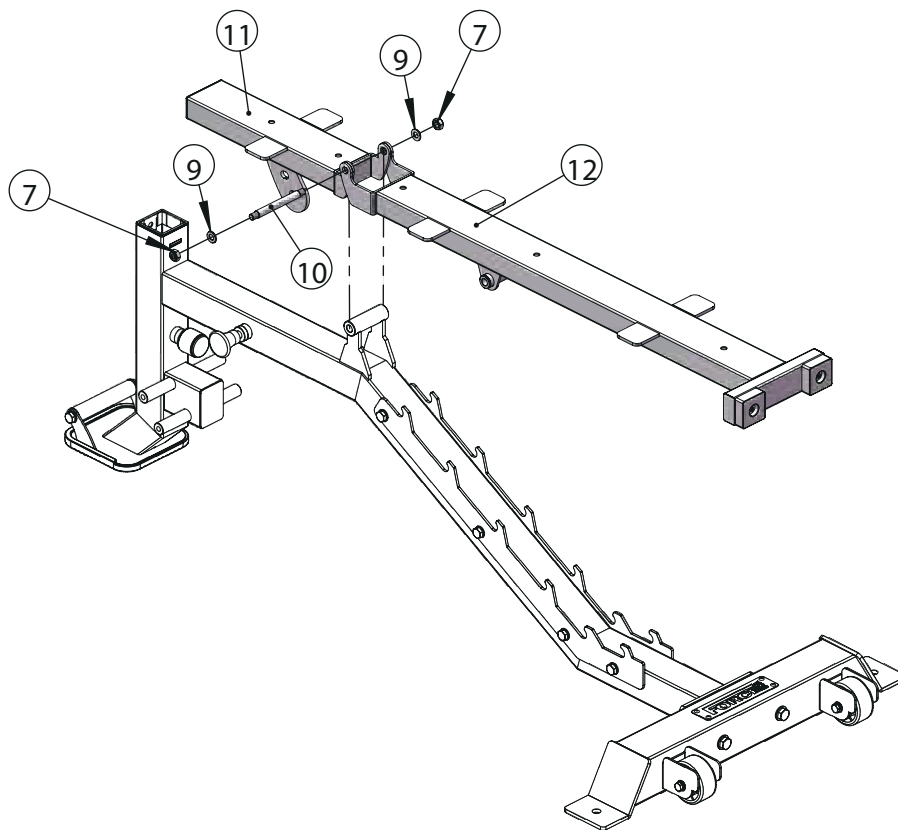

Key No.	Description	Note	Quantity
7	Lock Nut	M10	2
9	Washer	$\phi 10$	2
10	Double Thread Bolt	$\phi 12 * M10 * 118$	1
11	Seat Pad Frame		1
12	Back Pad Frame		1

ASSEMBLY STEP 4

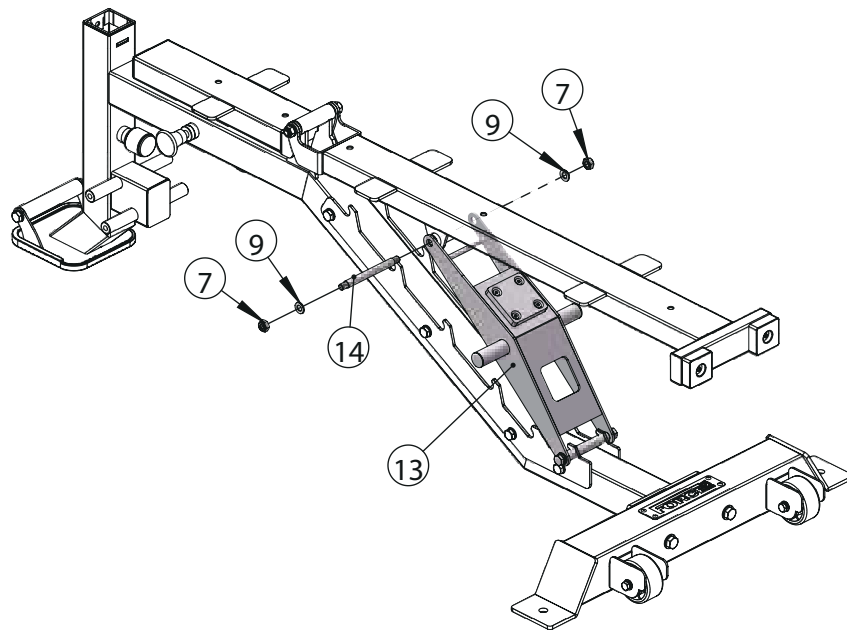

Key No.	Description	Note	Quantity
7	Lock Nut	M10	2
9	Washer	$\phi 10$	2
13	Angle Adjustment Frame		1
14	Double Thread Bolt	$\phi 12 \times 129.5 - M10$	1

ASSEMBLY STEP 5

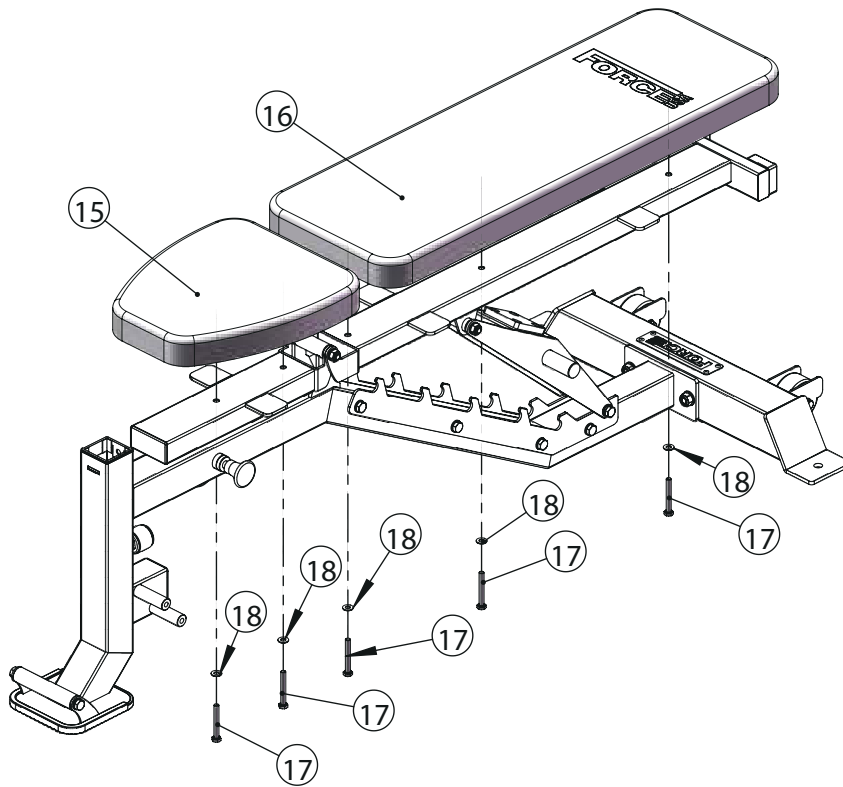

Key No.	Description	Note	Quantity
15	Seat Pad		1
16	Back Pad		1
17	Hexagon Head Bolt	M8×60	5
18	Washer	φ8	5

ASSEMBLY STEP 6

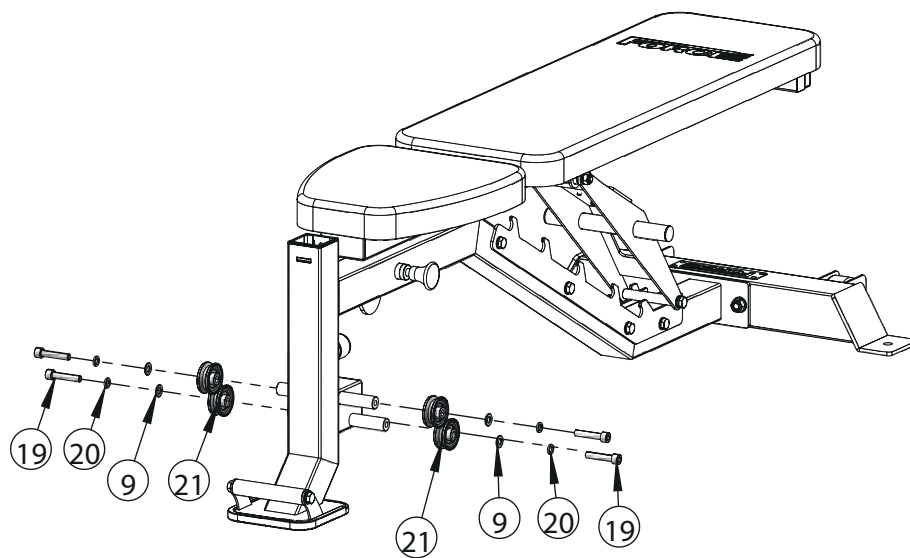

Key No.	Description	Note	Quantity
9	Washer	φ10	4
19	Inner Hexagon Column Head Screw	M10×50	4
20	Spring Washer	φ10	4
21	Pulley	φ50	4

ASSEMBLY STEP 7

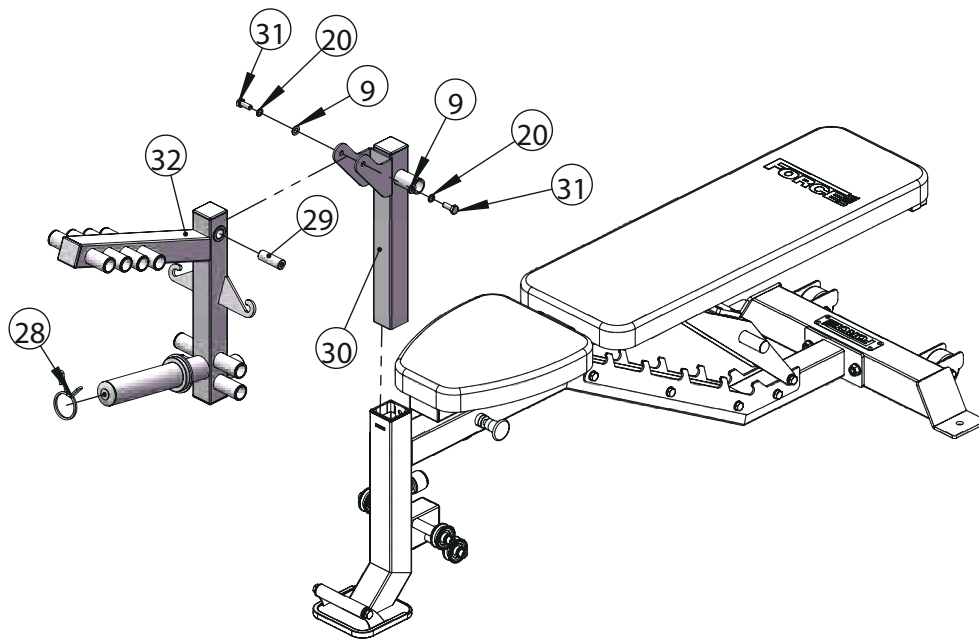

Key No.	Description	Note	Quantity
9	Washer	$\phi 10$	2
20	Spring Washer	$\phi 10$	2
28	Spring Collar	$\phi 50$	1
29	Leg Curl Extension Inner Shaft	$\phi 20 \times 57 - M10$	1
30	Leg Curl Extension Mounting Frame		1
31	Hexagon Head Bolt	M10 \times 25	2
32	Leg Curl Extension Frame		1

ASSEMBLY STEP 8

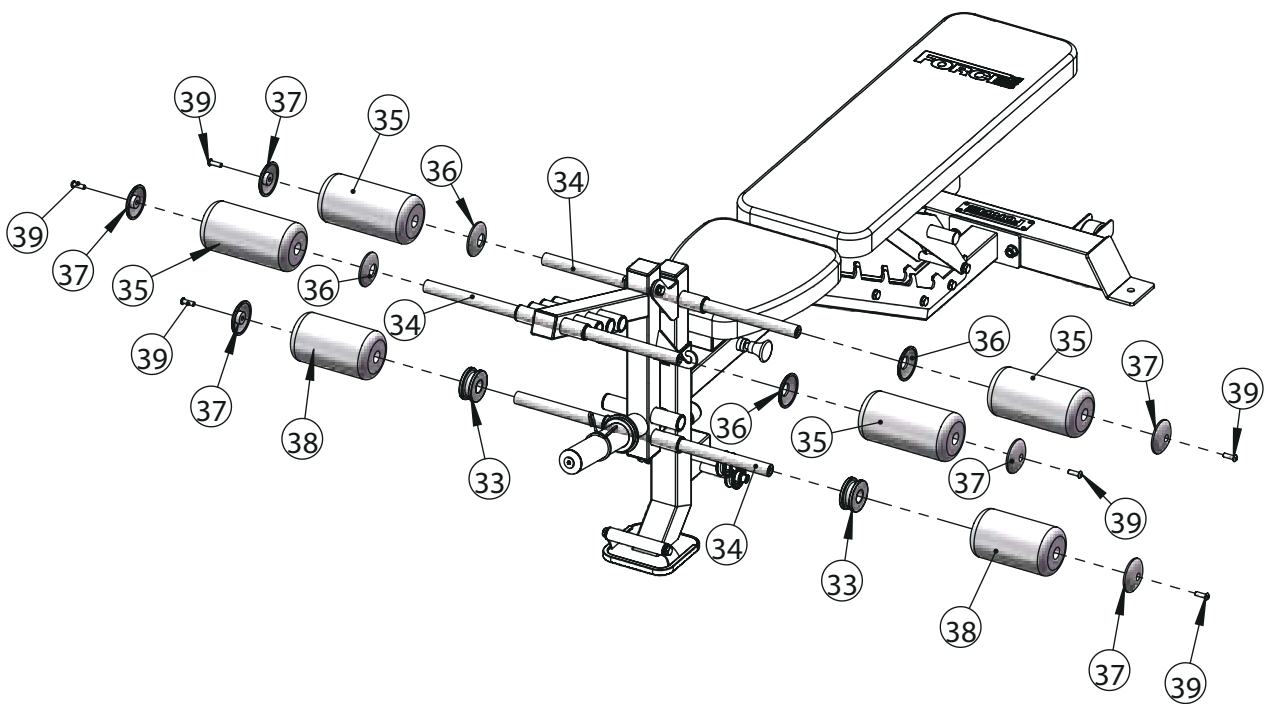

Key No.	Description	Note	Quantity
33	Pulley	$\phi 78 \times \phi 26 \times 28$	2
34	Foam Pad Rod		3
35	Upper Foam Pad	$\phi 25 \times \phi 100 \times 200$	4
36	Foam Pad Inner Cover Plate	$\phi 70 \times \phi 27 \times 12$	4
37	Foam Pad Outer Cover Plate	$\phi 70 \times \phi 9 \times 14$	6
38	Lower Foam Pad	$\phi 25 \times \phi 100 \times 175$	2
39	Hexagon Socket Button Head Screw	M8 \times 25	6

ASSEMBLY STEP 9

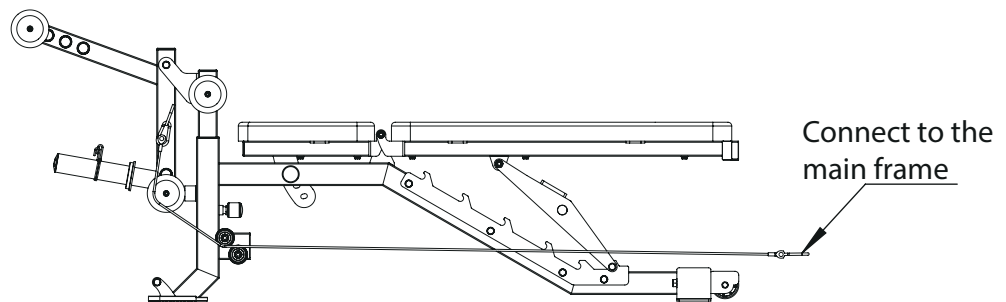
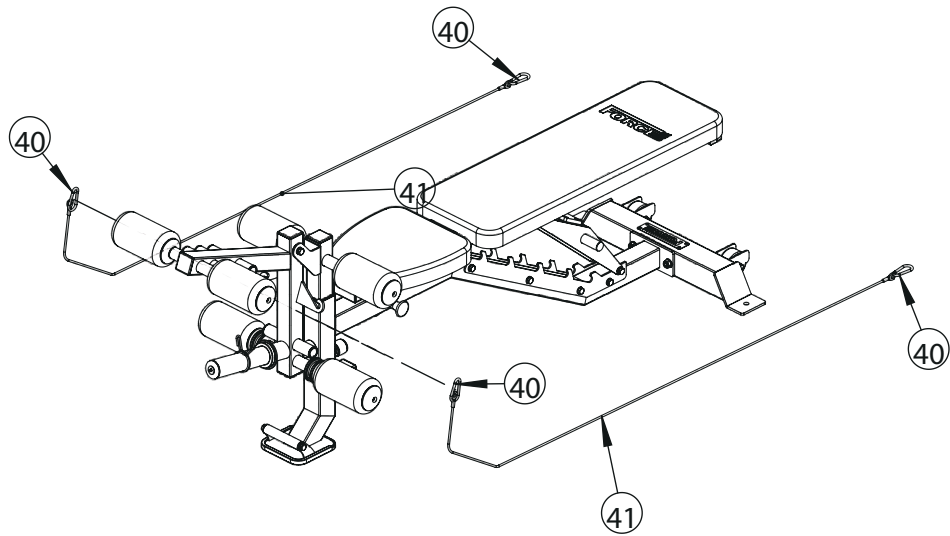

Key No.	Description	Note	Quantity
40	Carabiner		4
41	Leg Curl Cable	1670 (mm)	2

ASSEMBLY STEP 10

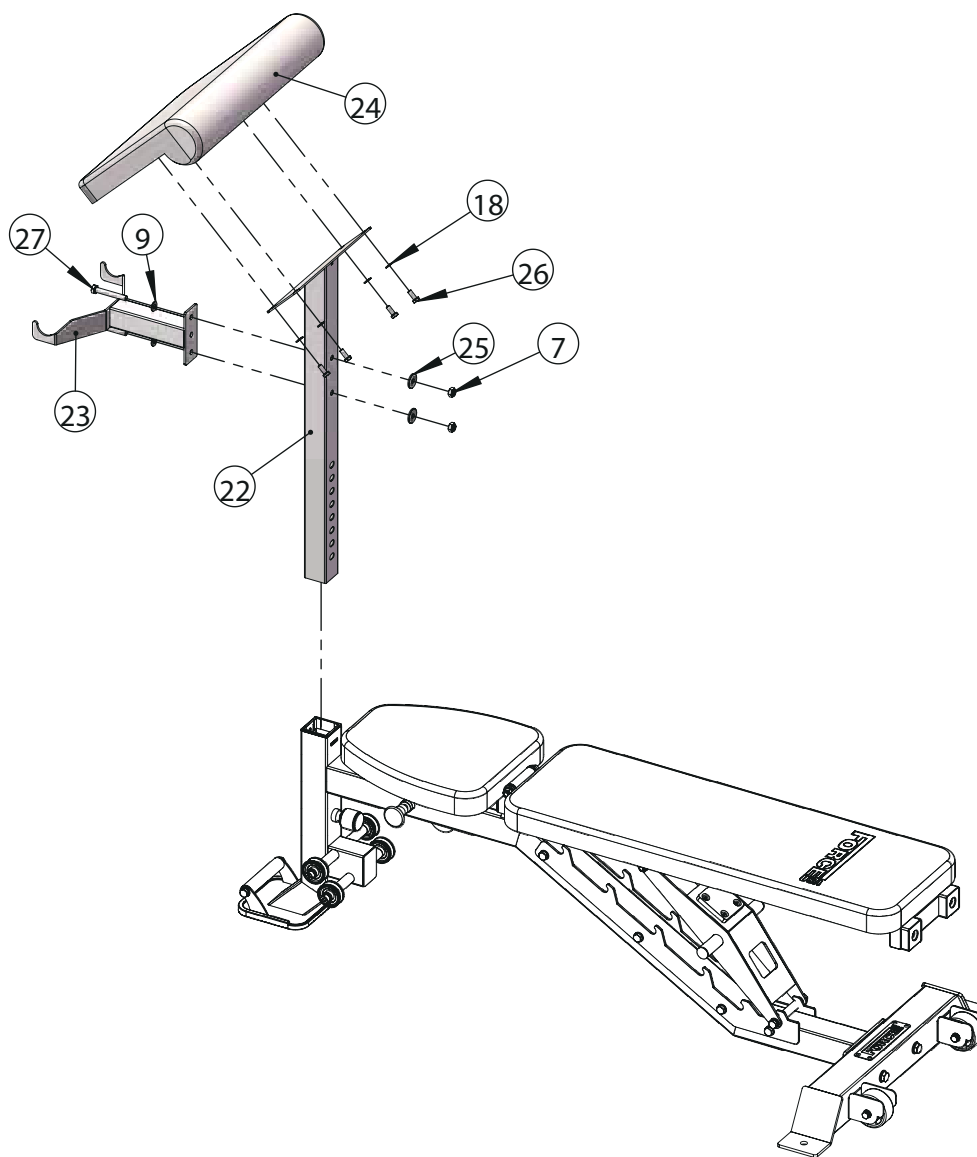

Key No.	Description	Note	Quantity
7	Lock Nut	M10	2
9	Washer	$\phi 10$	2
18	Washer	$\phi 8$	4
22	Preacher Curl Frame		1
23	Preacher Curl Barbell Holder		1
24	Preacher Curl Pad		1
25	Large Washer	$\phi 30 * \phi 10 * 3$	2
26	Hexagon Head Bolt	M8x20	4
27	Hexagon Head Bolt	M10x70	2

ASSEMBLY DRAWING

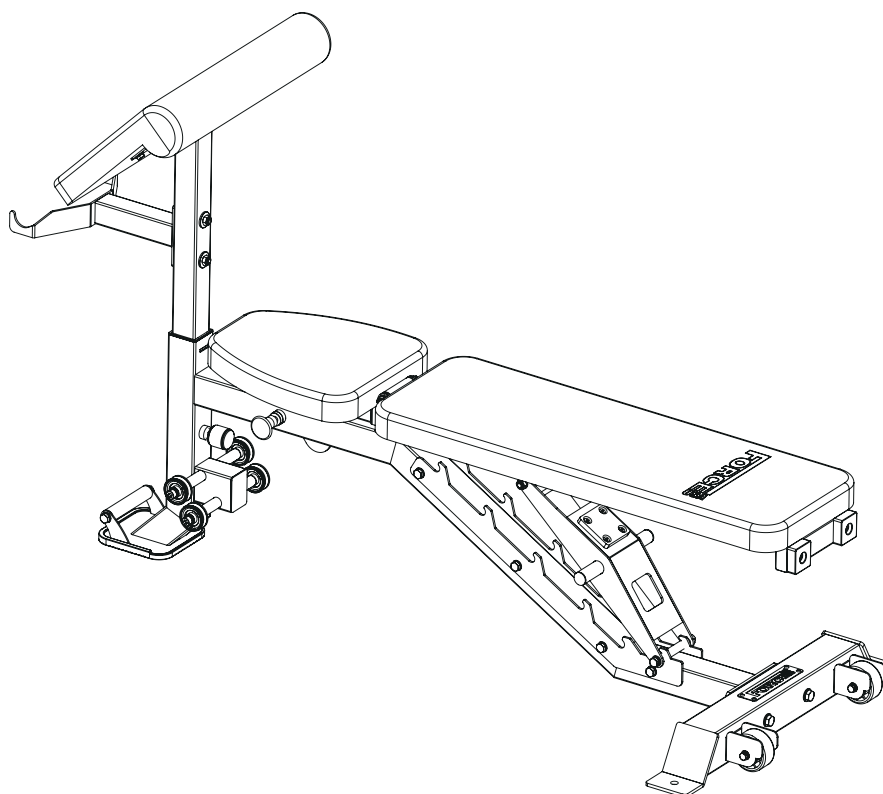

EXPLODED DIAGRAM

1. Main Base Frame, 1 pc

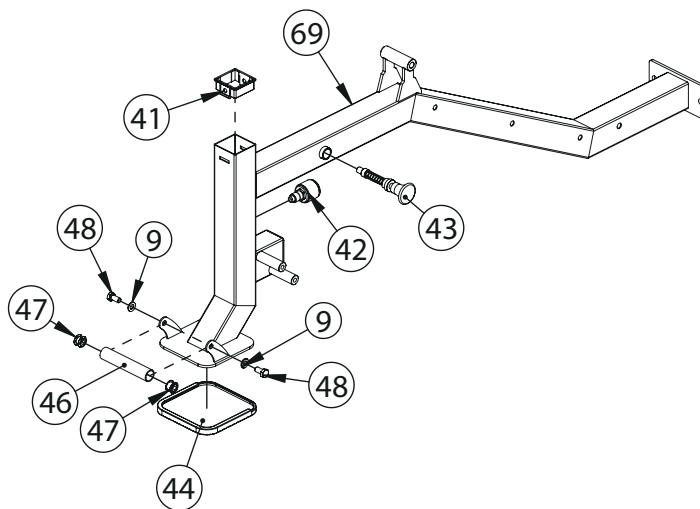
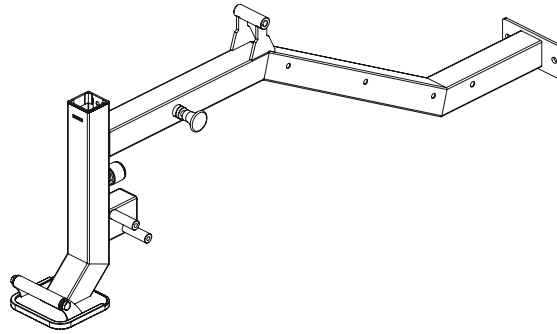

Key No.	Description	Note	Quantity
9	Washer	$\phi 10$	2
42	Plum Pin	$\phi 12$	1
43	Umbrella Pull Pin	$\phi 12 \times M20 \times 75$	1
44	Foot Pad	F150	1
45	Inner Plug	50*70*2	1
46	Movable Handle	$\phi 25 \times 1.5$	1
47	Two Layer Spring Slice Nut	$\phi 23 - M10$	2
48	Hexagon Head Bolt	M10*20	2
69	Main Beam Tube		1
76	Bushing	50-60	1

EXPLODED DIAGRAM

2. Rear Base Frame, 1 pc

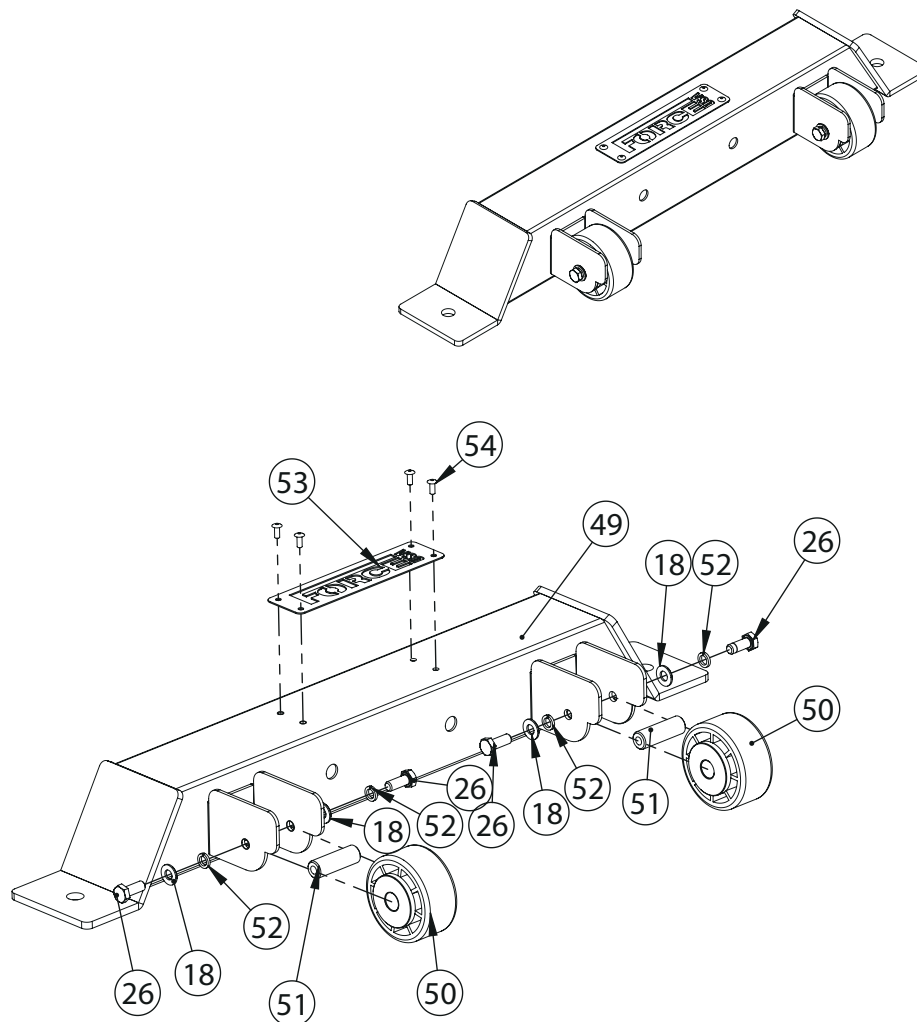

Key No.	Description	Note	Quantity
18	Washer	$\phi 8$	4
26	Hexagon Head Bolt	M8×20	4
49	Rear Bottom Beam		1
50	Movable Roller	$\phi 70$	2
51	Roller Shaft	$\phi 14.9 \times 45$ -M8	2
52	Spring Gasket	$\phi 8$	4
53	Lable Plate	T1	1
54	Flat Round Head No Core Rivet	4×10	4

EXPLODED DIAGRAM

11. Seat Pad Frame, 1 pc

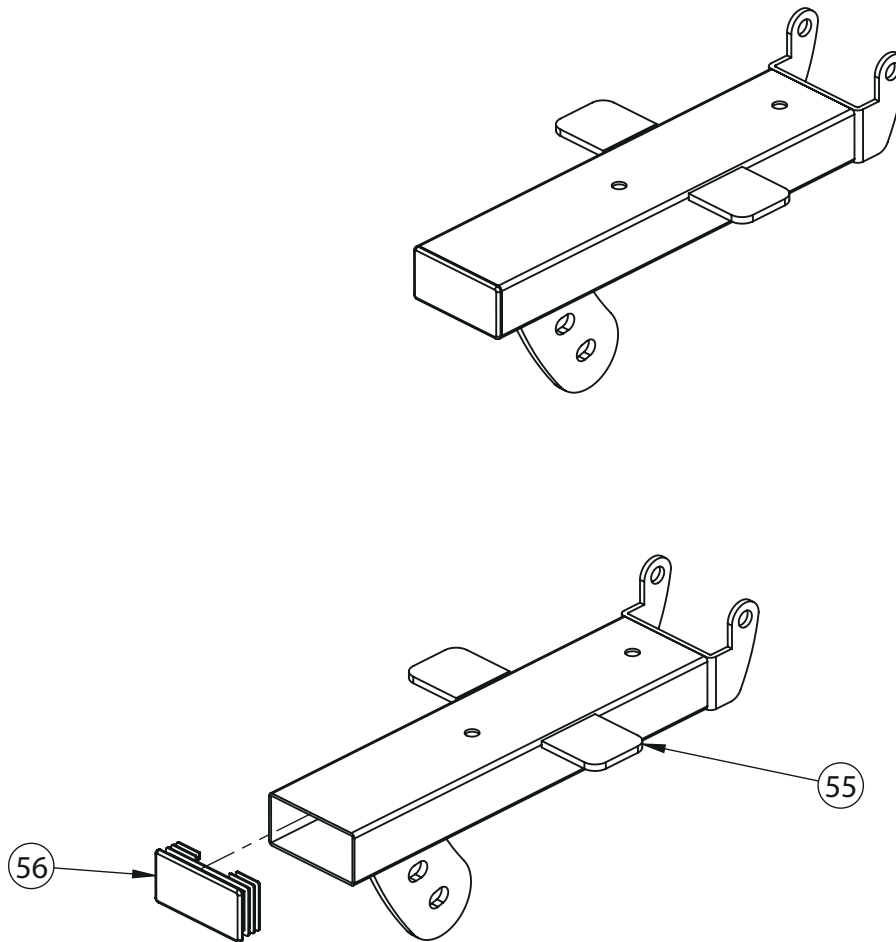

Key No.	Description	Note	Quantity
55	Seat Tube		1
56	Square Tube Inner Plug	□40×80×2	1

EXPLODED DIAGRAM

12. Back Pad Frame, 1 pc

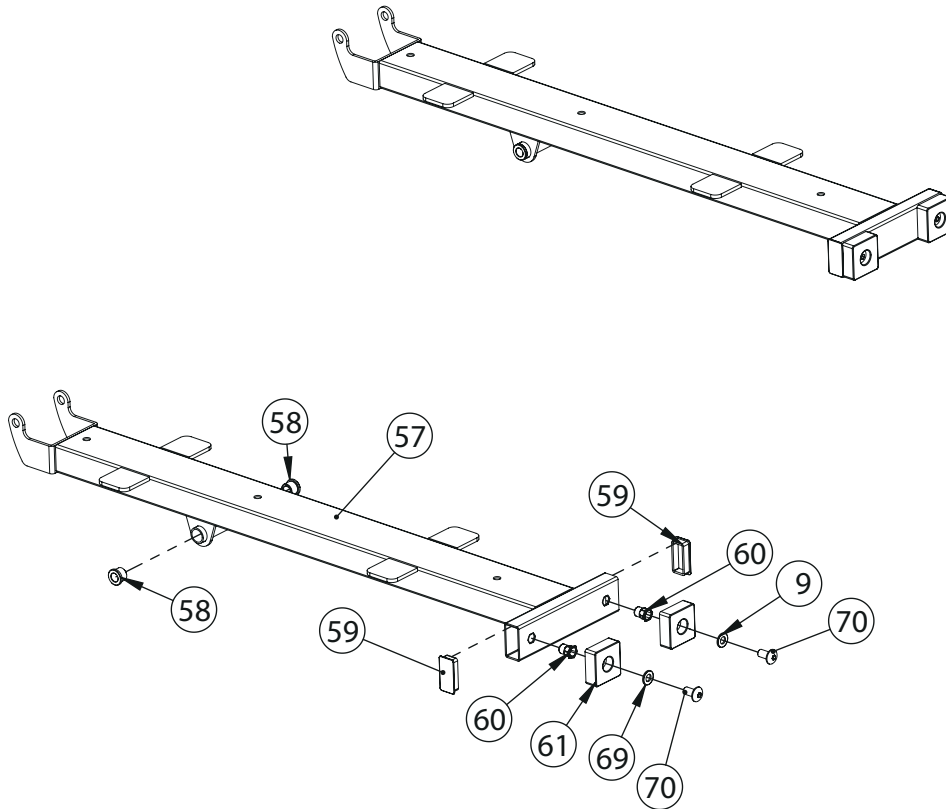

Key No.	Description	Note	Quantity
9	Washer	$\phi 10$	2
57	Back Pad Tube		1
58	Powder Sleeve	$\phi 22 \times \phi 18 \times \phi 12.2 \times 15$	2
59	Square Tube Inner Plug	$\square 25 \times 50 \times 1.5$	2
60	Sunk Head Hexagon Rivet Nut	M10	2
61	Square Shock Pad	$\square 50 \times 50 \times 18$	2
70	Inner Hexagon Flat Round Head Bolt	M10 \times 20	2

EXPLODED DIAGRAM

13. Angle Adjustment Frame, 1 pc

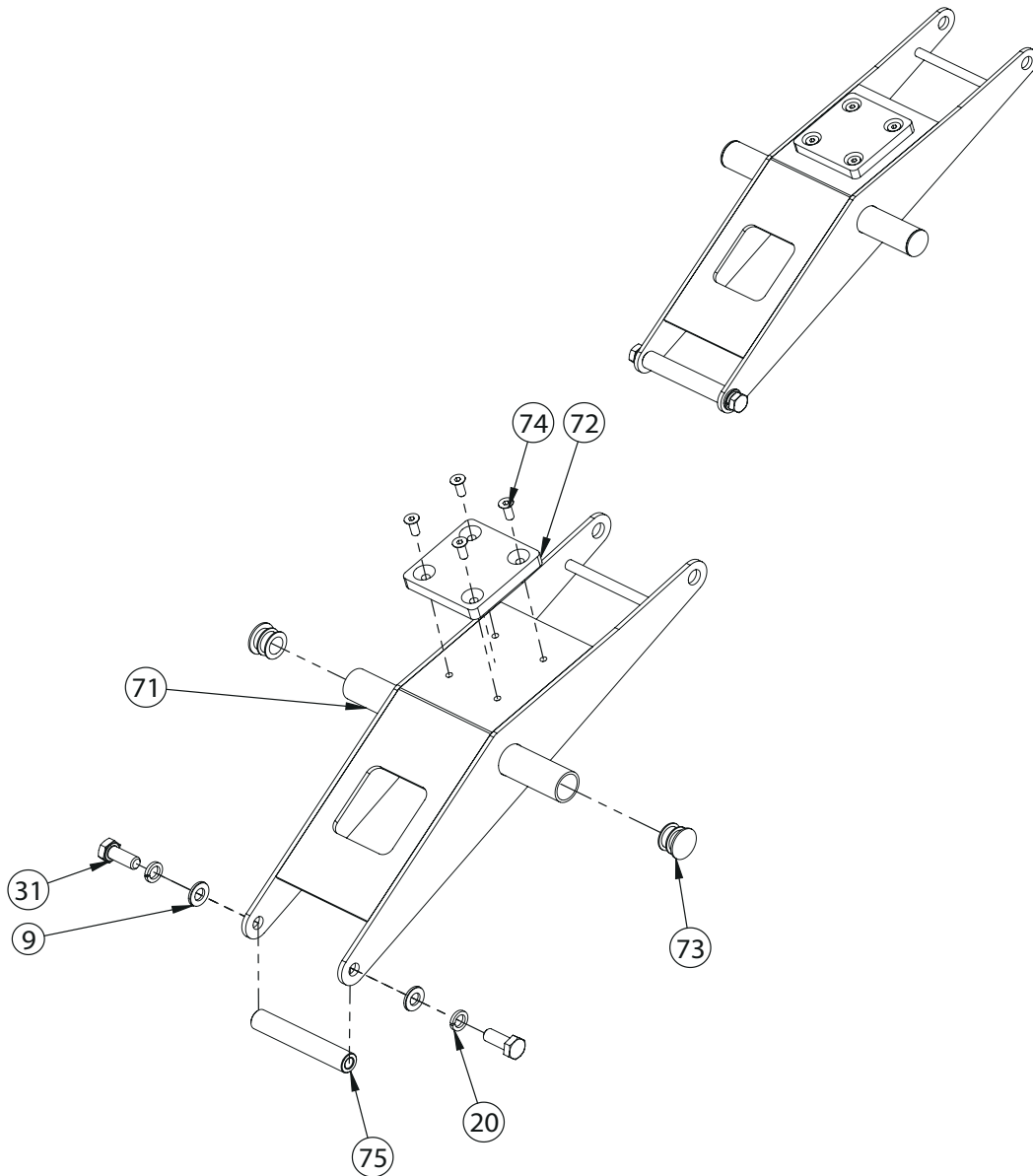

Key No.	Description	Note	Quantity
9	Washer	$\phi 10$	2
20	Spring Washer	$\phi 10$	2
31	Hexagon Head Bolt	M10×25	2
71	Back Pad Rear Support		1
72	Back Support Rubber Pad	T10	1
73	Round Tube Inner Plug	$\phi 25 \times 2$	2
74	Inner Hexagon Sunk Head Bolt	M6×16	4
75	Inner Shaft	$\phi 16 \times 95$	1

EXPLODED DIAGRAM

30. Leg Curl Extension Mounting Frame, 1 pc

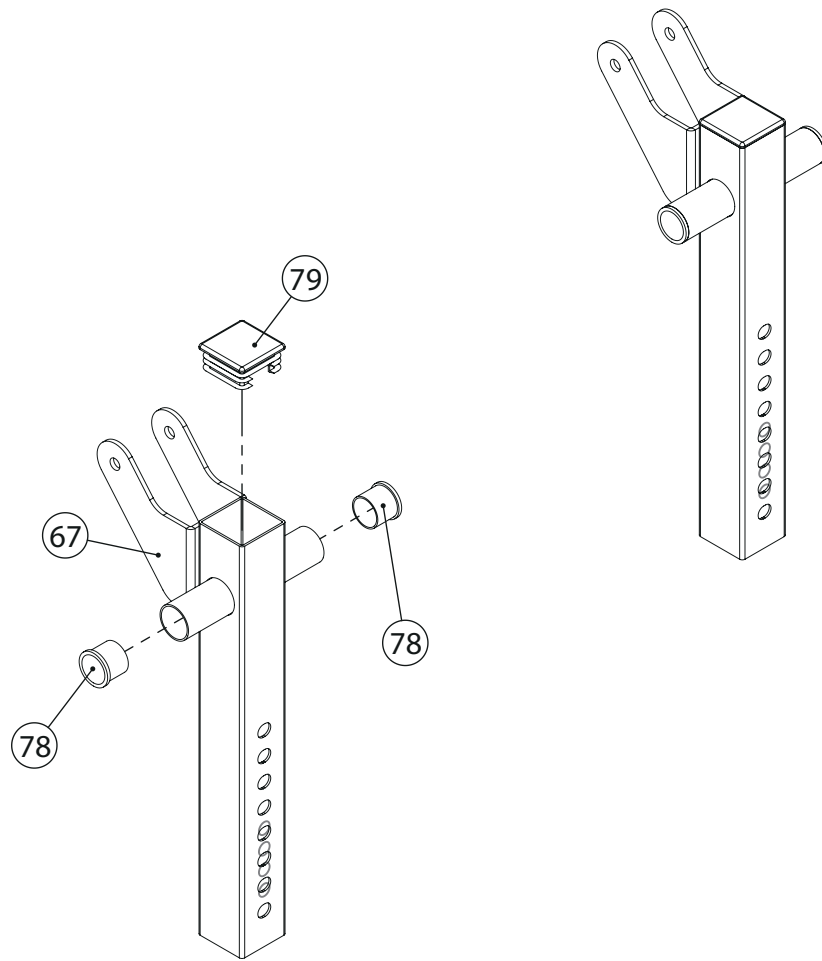

Key No.	Description	Note	Quantity
67	Leg Curl Inner Inserting Tube		1
78	Round Reducing Sleeve	$\phi 32 \times \phi 26 \times 25$	2
79	Square Tube Inner Plug	$\square 50 \times 50 \times 2$	1

EXPLODED DIAGRAM

32. Leg Curl Extension Frame, 1 pc

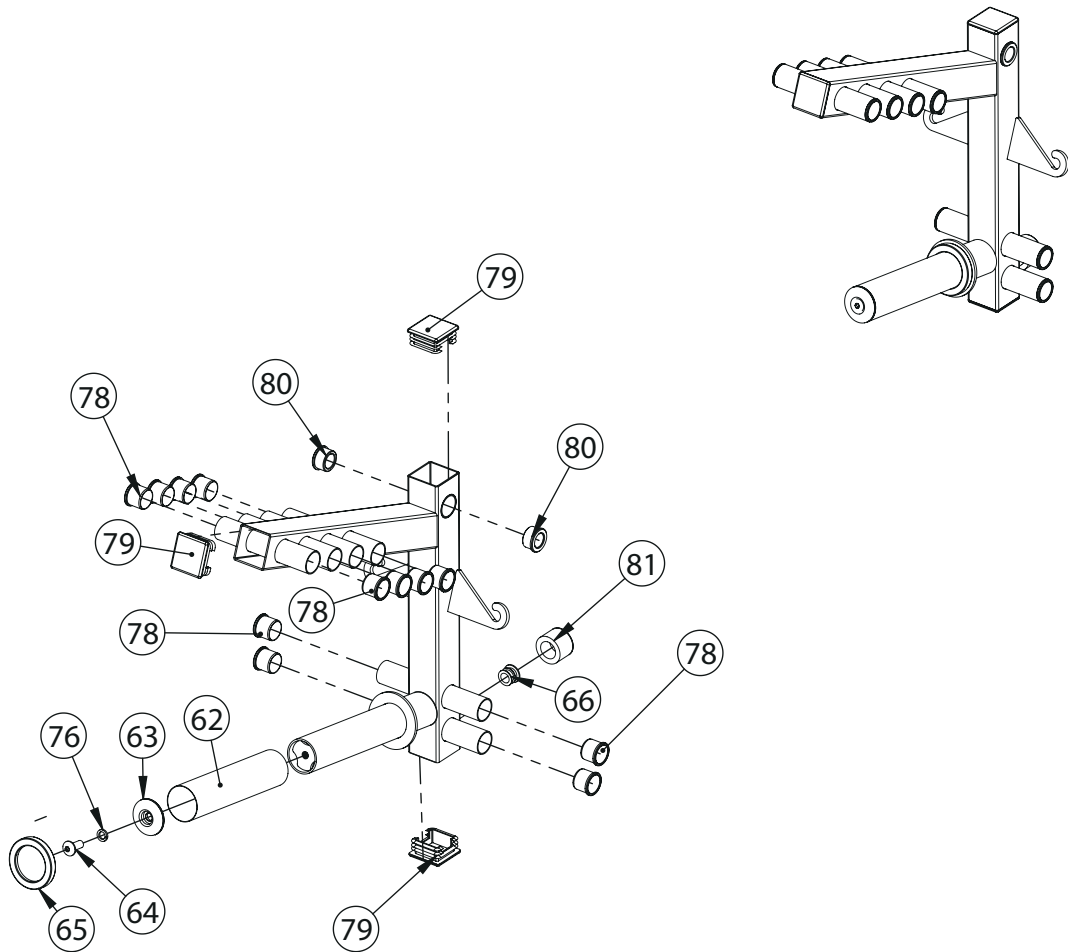

Key No.	Description	Note	Quantity
62	Stainless Steel Outer Sleeve Tube	$\phi 49.5 \times 0.6 \times 200$	1
63	Decorative Aluminium Cover	$\phi 11 \times \phi 18 \times \phi 42 \times \phi 50$	1
64	Inner Hexagon Flat Round Head Bolt	M10 \times 25	1
65	Rubber Stopper	$\phi 70 \times \phi 50 \times \phi 10$	1
66	Round Tube Inner Plug	$\phi 25 \times 2$	1
76	Bushing	50-60	1
77	Leg Curl Frame		1
78	Round Reducing Sleeve	$\phi 32 \times \phi 26 \times 25$	12
79	Square Tube Inner Plug	$\square 50 \times 50 \times 2$	3
80	Powder Sleeve	$\phi 33 \times \phi 29 \times \phi 20 \times 18$	2
81	Rubber Round Pad	$\phi 40 \times \phi 25 \times \phi 11 \times 29$	1

EXPLODED DIAGRAM

34. Foam Pad Rod, 3 pcs

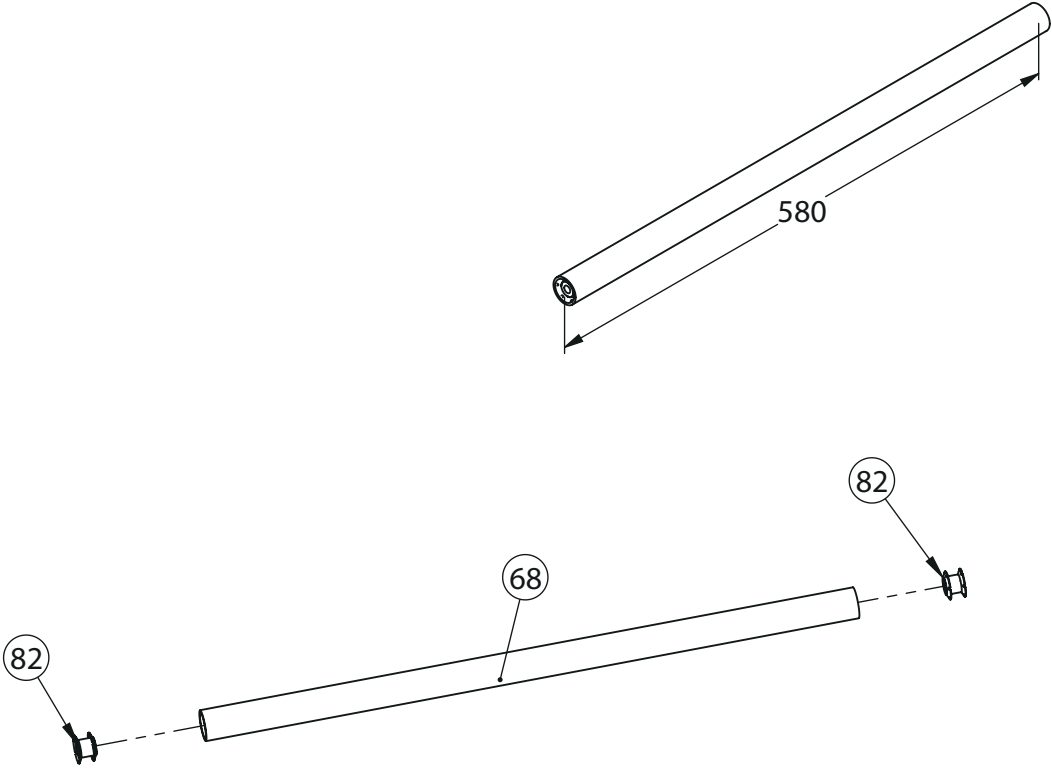

Key No.	Description	Note	Quantity
68	Foam Roller Supporting Rod- 580	$\phi 25 \times 2$	1
82	Two Layer Spring Slice Nut	$\phi 23 \text{-M}8$	2

PARTS LIST

Key No.	Description	Note	Quantity
1	Main Base Frame		1
2	Rear Base Frame		1
3	Washer	φ12	4
4	Lock Nut	M12	2
5	Hexagon Head Bolt	M12×95	2
6	Adjustment Angle Locking Plate	T4	2
7	Lock Nut	M10	10
8	Hexagon Head Bolt	M10×80	4
9	Washer	φ10	26
10	Double Thread Bolt	φ12*M10*118	1
11	Seat Pad Frame		1
12	Back Pad Frame		1
13	Angle Adjustment Frame		1
14	Double Thread Bolt	φ12×129.5-M10	1
15	Seat Pad		1
16	Back Pad		1
17	Hexagon Head Bolt	M8×60	5
18	Washer	φ8	13
19	Inner Hexagon Column Head Screw	M10×50	4
20	Spring Washer	φ10	9
21	Pulley	φ50	4
22	Preacher Curl Frame	Welding Part	1
23	Preacher Curl Barbell Holder	Welding Part	1
24	Preacher Curl Pad		1
25	Large Washer	φ30*φ10*3	2
26	Hexagon Head Bolt	M8×20	8
27	Hexagon Head Bolt	M10×70	2
28	Spring Collar	φ50	1
29	Leg Curl Extension Inner Shaft	φ20×57-M10	1
30	Leg Curl Extension Mounting Frame		1
31	Hexagon Head Bolt	M10×25	4
32	Leg Curl Extension Frame		1
33	Pulley	φ78×φ26×28	2
34	Foam Pad Rod		3
35	Upper Foam Pad	φ25Xφ100X200	4

PARTS LIST

Key No.	Description	Note	Quantity
36	Foam Pad Inner Cover Plate	φ70×φ27×12	4
37	Foam Pad Outer Cover Plate	φ70×φ9×14	6
38	Lower Foam Pad	φ25Xφ100X175	6
39	Hexagon Socket Button Head Screw	M8×25	6
40	Carabiner		4
41	Leg Curl Cable	1670 (mm)	2
42	Plum Pin	φ12	1
43	Umbrella Pull Pin	φ12×M20×75	1
44	Foot Pad	F150	1
45	Inner Plug	50*70*2	1
46	Movable Handle	φ25*1.5	1
47	Two Layer Spring Slice Nut	φ23-M10	2
48	Hexagon Head Bolt	M10×20	2
49	Rear Bottom Beam	Welding Part	1
50	Movable Roller	φ70	2
51	Roller Shaft	φ14.9×45-M8	2
52	Spring Gasket	φ8	4
53	Lable Plate	T1	1
54	Flat Round Head No Core Rivet	4×10	4
55	Seat Tube	Welding Part	1
56	Square Tube Inner Plug	□40×80×2	1
57	Back Pad Tube	Welding Part	1
58	Powder Sleeve	φ22×φ18×φ12.2×15	2
59	Square Tube Inner Plug	□25×50×1.5	2
60	Sunk Head Hexagon Rivet Nut	M10	2
61	Square Shock Pad	□50×50×18	2
62	Stainless Steel Outer Sleeve Tube	φ49.5*0.6*200	1
63	Decorative Aluminium Cover	φ11×φ18×φ42×φ50	1
64	Inner Hexagon Flat Round Head Bolt	M10×25	1
65	Rubber Stopper	φ70×φ50×φ10	1
66	Round Tube Inner Plug	Φ25×2	1
67	Leg Curl Inner Inserting Tube	Welding Part	1
68	Foam Roller Supporting Rod- 580	φ25*2	1
69	Main Beam Tube	Welding Part	1
70	Inner Hexagon Flat Round Head Bolt	M10×20	2

PARTS LIST

Key No.	Description	Note	Quantity
71	Back Pad Rear Support	Welding Part	1
72	Back Support Rubber Pad	T10	1
73	Round Tube Inner Plug	Φ25×2	2
74	Inner Hexagon Sunk Head Bolt	M6×16	4
75	Inner Shaft	Φ16*95	1
76	Bushing	50-60	1
77	Leg Curl Frame	Welding Part	1
78	Round Reducing Sleeve	φ32×φ26×25	14
79	Square Tube Inner Plug	□50×50×2	4
80	Powder Sleeve	φ33×φ29×φ20×18	2
81	Rubber Round Pad	φ40*φ25*φ11*29	1
82	Two Layer Spring Slice Nut	φ23-M8	6

MEASURING FOR BOLT LENGTH





We believe success comes from striving to be better than yesterday. It comes from the urge to push boundaries and break through barriers. Fueled with the belief that everybody deserves a fit and healthy lifestyle, we are dedicated to providing innovative strength and fitness solutions to build stronger, happier and healthier lives.

WARRANTY

The Force USA range of strength equipment carries a Lifetime (10 Year) Structural Warranty along with two years cover on all moving parts and 90 days warranty on all upholstery items. This warranty applies to first owners and does not cover second-hand equipment or re-sold equipment. This Force USA warranty covers only failures due to defects in structural elements, cables and pulleys and workmanship that occur during regular use in the warranted environment. It will not cover damage that occurs in transport/delivery or failure due to misuse, abuse, neglect, misapplication, alteration or improper assembly of the product. The replacement or repair provided for under the Force USA warranty is the responsibility of the user, and the customer will be responsible for any freight charges that apply. Force USA will not be liable for any consequential damages or breach of any implied warranty on the range of Force USA strength equipment. Force USA reserves the right to provide reconditioned parts and/or to request a return and repair existing defective components on the Force USA product.