



Assembly and Operating Instructions



max. 150 kg



~ 30 Min.



93 kg

L 188 | B 89 | H 147

FSUKTX70.02.01

SKU: CST-TX70-2

Treadmill TX70

Content

1	GENERAL INFORMATION	8
1.1	Technical Data	8
1.2	Personal Safety	9
1.3	Electrical Safety	10
1.4	Set-Up Place	11
2	ASSEMBLY	12
2.1	General Instructions	12
2.2	Scope of Delivery	13
2.3	Assembly	14
3	OPERATING INSTRUCTIONS	22
3.1	Console Display	23
3.1.1	Rotary Knob Function	24
3.2	Media Management	24
3.3	Applications	24
3.4	Workout Programmes	26
3.4.1	Programmes	26
3.5	User-defined Programmes	30
3.6	Hand Pulse Sensors	31
3.7	Lubrication Reminder Function	31
3.8	Saving Energy	31
3.9	Power Switch	31
3.10	Wireless Connection and Fitness Apps	32
4	STORAGE AND TRANSPORT	33
4.1	General Instructions	33
4.2	Transportation Wheels	33
4.3	Folding Mechanism	33
4.3.1	Folding Up the Treadmill	34
4.3.2	Unfolding the Treadmill	34
5	TROUBLESHOOTING, CARE AND MAINTENANCE	35
5.1	General Instructions	35
5.2	Faults and Fault Diagnosis	35
5.3	Error Codes and Troubleshooting	36
5.4	Care and Maintenance	37
5.4.1	Adjusting the Running Mat	37
5.4.2	Re-tensioning the Running Mat	38

5.4.3	Lubricating the Running Mat	38
5.5	Maintenance and Inspection Calendar	39
6	DISPOSAL	39
7	RECOMMENDED ACCESSORIES	40
8	ORDERING SPARE PARTS	41
8.1	Serial Number and Model Name	41
8.2	Parts List	42
8.3	Exploded Drawing	47
9	WARRANTY	50
10	CONTACT	52

Dear customer,

thank you for choosing fitness equipment from cardiostrong®. cardiostrong offers high-quality home fitness equipment that is optimally adapted to the conditions at home. Train at home no matter what the weather or time of the day. cardiostrong fitness equipment offers training programmes and a variety of equipment for all training levels and all training goals. Further information can be found at www.fitshop.com or www.cardiostrong.de. We hope you enjoy your training!
Further information can be found at www.fitshop.co.uk

Intended Use

The equipment may only be used for its intended purpose.

The equipment is only suitable for home use. The equipment is not suitable for semi-professional (e.g. hospitals, associations, hotels, schools, etc.) and commercial or professional use (e.g. fitness studios).

Legal Notice

Fitshop GmbH
Europe's No. 1 for home fitness

International Headquarters
Flensburger Straße 55
24837 Schleswig
Germany

Management:
Christian Grau
Sebastian Campmann
Dr. Bernhard Schenkel
No. HRB 1000 SL
Local Court Flensburg
European VAT Number: DE813211547

Disclaimer

© cardiostrong is a registered brand of the company Fitshop GmbH. All rights reserved. Any use of this trademark without the explicit written permission of Fitshop is prohibited.

Product and manual are subject to change. Technical data can be changed without advance notice.

FITSHOP

Europe's No.1 for Home Fitness

ABOUT THIS MANUAL

Please carefully read the entire manual before installation and first use. The manual will help you to quickly set up the system and explains how to safely use it. Make sure that all persons exercising with the equipment (especially children and persons with physical, sensory, mental or motor disabilities) are informed about this manual and its contents in advance. In case of doubt, responsible persons must supervise the use of the equipment.

Due to ongoing changes and software optimisations, the manual may have to be updated. If you notice any discrepancies during assembly or use, please refer to the manual uploaded to the webshop. The latest manual is always available there.



This equipment has been manufactured according to the latest safety knowledge. As far as possible, potential safety hazards which could cause injury have been eliminated. Make sure to carefully follow the instructions and that all parts are securely in place. If required, read through the instructions again to correct any mistakes.

Training devices must be classified according to accuracy and use. Accuracy classes are only applicable to devices that display training data.

Accuracy classes

Class A: high accuracy.

Class B: medium accuracy.

Class C: low accuracy.

The use classes explain the intended use of the training device.

Use classes

Class S (studio): professional and/or commercial use.

These training devices are intended for the use in training rooms of facilities such as sports clubs, school facilities, hotels, clubs and studios whose access and supervision is specifically regulated by the owner (person with legal responsibility).

Class H (home use): use at home.

These stationary training devices are intended for the use in private homes where access to the training device is regulated by the owner (person with legal responsibility).

Please pay close attention to the safety and maintenance instructions given here. The contract partner cannot be held liable for damage to health, accidents or damage to the equipment when it is not used in accordance with these instructions.

The following safety instructions may appear in this manual:

► **ATTENTION**

This notice indicates potentially hazardous situations which, if not avoided, may result in property damage.

⚠ **CAUTION**

This notice indicates potentially hazardous situations which, if not avoided, may result in slight or minor injuries!

⚠ **WARNING**

This notice indicates potentially hazardous situations which, if not avoided, may result in death or serious injuries!

⚠ **DANGER**

This notice indicates potentially hazardous situations which, if not avoided, will result in death or serious injuries!

ⓘ **NOTICE**

This notice indicates further useful information.

Retain these instructions in a safe place for future reference, maintenance or when ordering replacement parts.

1.1 Technical Data

Console-Display

- + Time
- + Speed
- + Distance
- + Calories
- + Incline
- + Pulse
- + Pace
- + Steps

Weight and dimensions:

Article weight (gross, including packaging):	106 kg
Article weight (net, without packaging):	93 kg
Packaging dimensions in cm (L x W x H):	202.5 x 96.5 x 32
Set-up dimensions in cm (L x W x H):	188 x 88.5 x 146.5
Folded dimensions in cm (Lx W x H):	108.5 x 88.5 x 164.5
Maximum user weight:	150 kg
Display size:	15.6 inches

Running mat:

Thickness:	2.5 mm
Running deck:	18 mm
Running mat size in cm (L x W):	150 x 51

Motor:

Minimum speed:	0.8 km/h
Maximum speed:	20 km/h
Speed interval:	0.1 km/h
Incline:	0 % - 15 %
Incline interval:	1 %
Mains supply:	Yes
Motor type:	DC
Use class:	H

1.2 Personal Safety

DANGER

- + Before you start using the equipment, you should consult your physician that this type of exercise is suitable for you from a health perspective. Particularly affected are persons who: have a hereditary disposition to high blood pressure or heart disease, are over the age of 45, smoke, have high cholesterol values, are overweight and/or have not exercised regularly in the past year. If you are under medical treatment that affects your heart rate, medical advice is absolutely essential.
- + Note that excessive training can seriously endanger your health. Please also note that heart rate monitoring systems can be inaccurate. If you notice any signs of weakness, nausea, dizziness, pain, shortness of breath, or other abnormal symptoms, stop exercising immediately and seek advice from your doctor if necessary.
- + The owner must communicate all warnings and instructions to the user.

WARNING

- + This equipment may not be used by children under the age of 14.
- + Children should not be allowed unsupervised access to the equipment.
- + Persons with disabilities must have a medical license and must be under strict observation when using the equipment.
- + The equipment is strictly for use by one person at a time.
- + If your equipment provides a safety key, the clip of the safety key must be attached to your clothing before starting your training. In the event of a fall, the EMERGENCY STOP of the equipment can be initiated.
- + If an emergency occurs and training has to be stopped abruptly, pull out the safety key, grab both handles, jump onto the side rails and wait until the treadmill has come to a complete stop.
- + Keep your hands, feet and other body parts, hair, clothing, jewellery and other objects well clear of moving parts.
- + During use, wear suitable sports clothing rather than loose or baggy clothing. When wearing sports shoes, make sure they have suitable soles, preferably made of rubber or other non-slip materials. Shoes with heels, leather soles, studs or spikes are unsuitable. Never exercise barefoot.

CAUTION

- + If your equipment needs to be connected to the power supply with a mains cable, make sure that the cable is not a potential tripping hazard.
- + Make sure that nobody is within the range of motion of the equipment during training so as not to endanger you or other persons.
- + Be aware that if adjustment devices are left protruding, they may impede the user's movement.

► **ATTENTION**

- + Do not insert any objects of any kind into the openings of the device.
- + To protect the equipment from use by unauthorised third parties, always remove the power cable (if existing) when not in use and store it in a safe place that is inaccessible to unauthorised persons (e.g. children).

1.3 Electrical Safety

⚠ **DANGER**

- + In order to reduce the risk of an electric shock, always unplug the equipment from the mains socket immediately after your workout, before assembly or dismantling, and before maintenance or cleaning. Do not pull on the cable.

⚠ **WARNING**

- + Do not leave the equipment unattended while the mains cable is plugged into the mains socket. During your absence, the mains cable must be removed from the mains socket to prevent improper use by third parties or children.
- + If the mains cable or plug is damaged or defective, contact your contract partner. Until repair, the equipment must not be used.

► **ATTENTION**

- + The equipment requires a mains connection of 220-230 V with 50 Hz mains voltage.
- + The equipment may only be connected directly to an earthed socket using the supplied mains cable. Extension cables must conform to VDE guidelines. Always completely unwind the mains cable.
- + The socket must be protected by a fuse with a minimum fuse rating of "16 A, slow blow".
- + Do not make any changes to the mains cable or the mains plug.
- + Keep the mains cable away from water, heat, oil and sharp edges. Do not route the mains cable underneath the equipment or under a carpet or rug, and do not place any objects on top of it.
- + If your purchased item is equipped with a TFT console, software updates must be carried out regularly. Follow the instructions on the console to perform the update(s).
- + The software systems on gym equipment with TFT consoles are set up only for the pre-installed apps. Do not install any additional apps.

ⓘ **NOTICE**

- + The pre-installed apps on TFT consoles are produced and provided by external manufacturers. Fitshop does not take any responsibility for the availability, functionality or contents of these apps.

1.4 Set-Up Place

⚠️ WARNING

- + Do not place the equipment in main corridors or escape routes.

⚠️ CAUTION

- + Make sure that there is a safety area behind the treadmill with a length of at least 2 m and a width at least equal to the width of the treadmill.
- + The training room should be well ventilated during training and not be exposed to any draughts.
- + Choose the place in which to set up the equipment such that there is enough free space/clearance to the front, the rear and to the sides of the equipment.
- + The free area in the direction from which the exercise equipment is accessed must be at least 0.6 m larger than the exercise area.
- + The set-up and mounting surface of the equipment should be flat, loadable and solid.

▶️ ATTENTION

- + The device may only be used in one building, in sufficiently tempered and dry rooms (ambient temperatures between 10°C and 35°C). The equipment should not be used outdoors or in rooms with high humidity (over 70%) like swimming pools.
- + A floor protective mat/equipment underlay can help to protect high-quality floor coverings (parquet, laminate, cork, carpets) from dents and sweat and can help to level out slight unevenness.
- + For Class S equipment, the exercise equipment may only be used in areas where access, supervision and control are specifically regulated by the owner.

Recommended free zone:

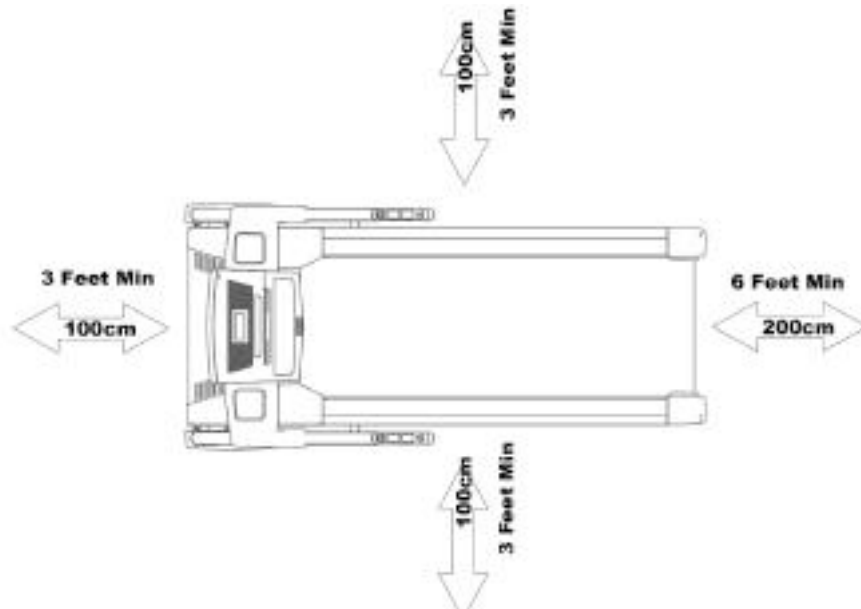

2.1 General Instructions

DANGER

- + Do not leave any tools, packaging materials such as foils or small parts lying around, as otherwise there is a danger of suffocation for children. Keep children away from the equipment during assembly.

WARNING

- + The treadmill is equipped with high-pressure shock absorbers that can cause the treadmill to suddenly open if handled incorrectly. To avoid possible personal injuries, never pull on the areas of the treadmill shown in the illustration. Never try to lift or move the treadmill at the marked areas.
- + Pay attention to the instructions attached to the equipment in order to reduce the risk of injuries.

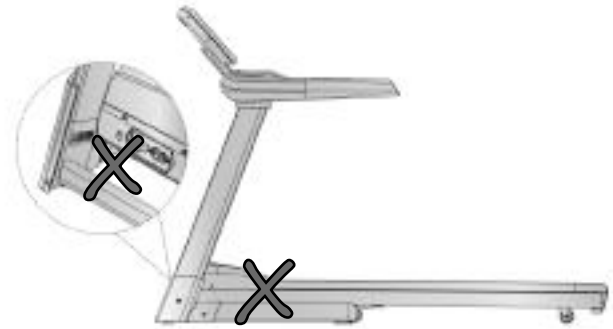

CAUTION

- + Ensure to have sufficient room for movement in each direction during assembly.
- + The assembly of the equipment must be carried out by at least two adults. If in doubt, seek the help of a third technically skilled person.

ATTENTION

- + To prevent damage to the equipment and the floor, assemble the equipment on a mat or packaging board.

NOTICE

- + In order to make the assembly as simple as possible, some screws and nuts to be used can already be pre-assembled.
- + Ideally, assemble the equipment at its later set-up place.

2.2 Scope of Delivery

⚠ WARNING







There is a transportation lock that prevents the treadmill from opening during transport. This transportation lock must be removed before assembly.

The scope of delivery consist of the following parts. At the beginning, check whether all parts and tools belonging to the device are included in the scope of delivery and whether damage has occurred. In the event of complaints, the contractual partner must be contacted directly.



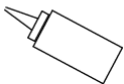
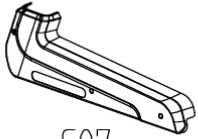



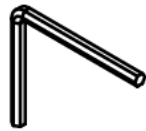
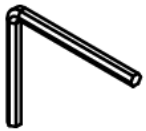

⚠ CAUTION

If parts of the scope of delivery are missing or damaged, the assembly must not be carried out.

Required tools (included in the scope of delivery): Spanner (5 mm, 6 mm), safety scissors

				
A	B	C	C07	C08
				
C19	E08			

NO.	DES.	Specification	Nos.
A	Main Frame		1
B	Console Base		1
C	Lubrication Oil		1
C07	Left Upright Tube Cover		1
C08	Right Upright Tube Cover		1
C19	Safety Key		1
E08	Power Wire		1

B04 S=13, 14, 15(1X)	B05 S5(1X)	B06 S6(1X)	D11 M8*15(2X)	D12 M8*15(4X)
				
D39 M5*10(6X)	D07 M8*50(2X)	D28 Ø8(4X)	D29 Ø8(4X)	D32 Ø8(4X)
				

2.3 Assembly

Before assembly, take a close look at the individual assembly steps shown and carry out the assembly in the order given.

① NOTICE

- + First loosely screw all parts together and check that they fit properly. Tighten the screws using the tool only when you are instructed to do so.
- + If you have difficulty recognising the graphics, we recommend that you open and/or download the PDF instructions stored in the webshop on your end device (e.g. smartphone, tablet or PC). There you have the option of zooming in closer. Please note that the Adobe Acrobat Reader programme must be installed on your end device in order to open the file.

Step 1: Removing the Packaging

1. Remove the main frame (A) and the console (B) from the packaging.
2. Inspect the components for damage and completeness.

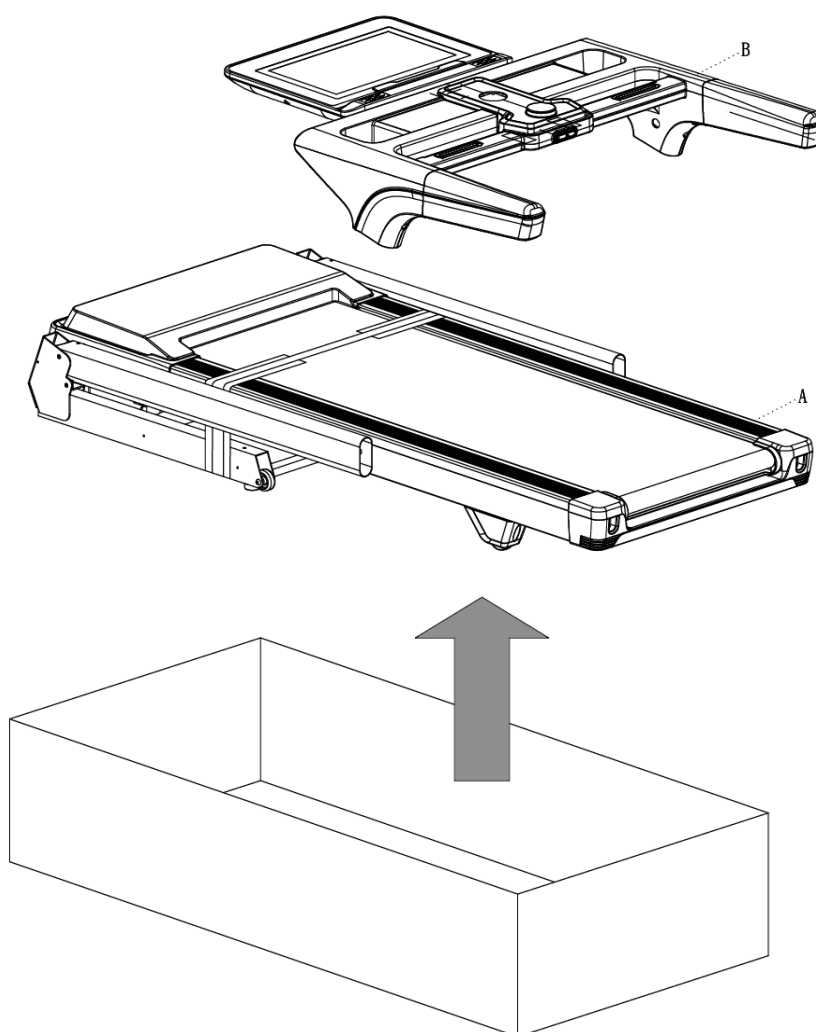

Step 2: Folding out the Upright Tubes

1. Fold the left and right upright tube (A06 & A07) into a vertical position.
2. Secure the position of the left and right upright tube (A06 & A07) on the sides with one bolt (D07) and one washer (D28) each.

Use the Allen key (B05) for this.

3. Secure the left and right upright tube (A06 & A07) at the rear position with one bolt (D11) and one washer (D28) each.

Use the Allen key (B05).

4. Tighten the screws firmly.

ⓘ NOTE

Ensure that the console bottom signal wire (E21) is accessible for step 3.

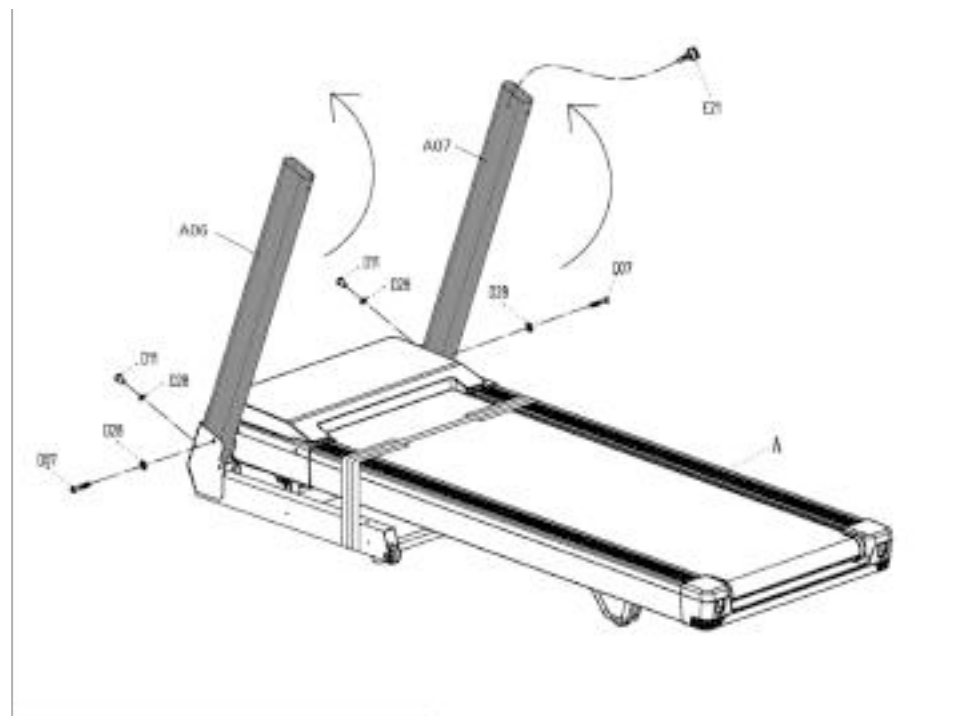

B05 5#(1x)	D11 M8*15(2x)
	
D28 $\phi 8(4x)$	D07 M8*50(2x)
	

Step 3: Attaching the Console

1. Connect the console middle signal wire (E20) to the console bottom signal wire (E21).

► **CAUTION**

Material damage due to pinching of the cable

Take care not to pinch the cable.

2. Secure the console (B) to the left and right upright tube (A06 & A07) with two bolts (D12), two spring washers (D29) and two washers (D32) each.

Use the Allen key (B06).

3. Tighten all screws firmly.

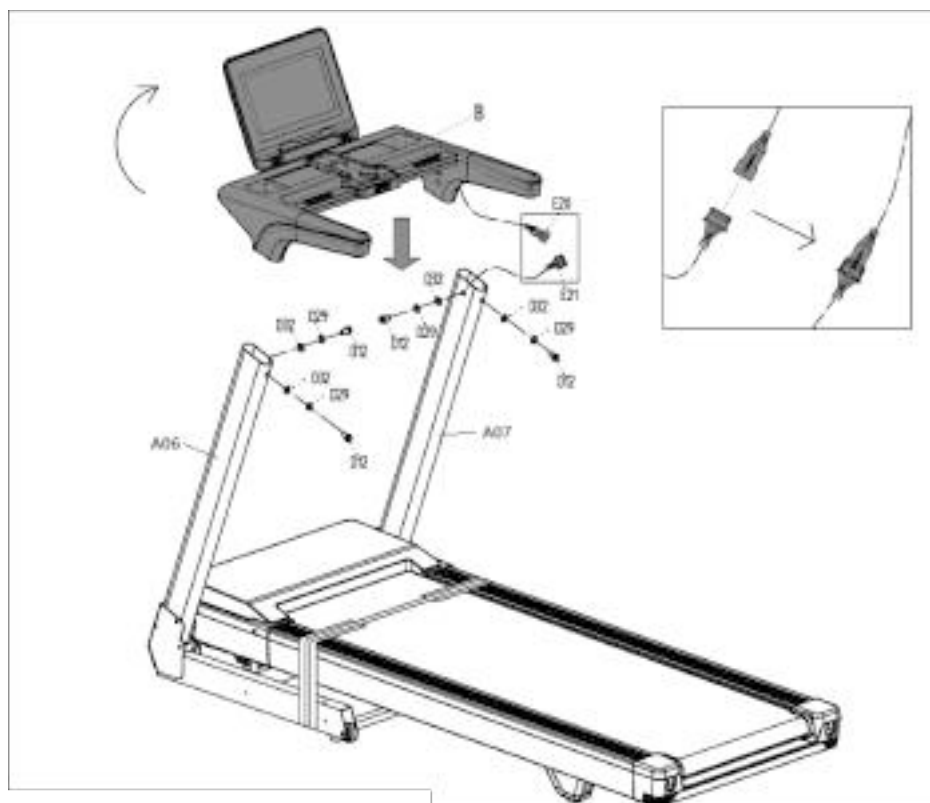

B06	6#(1X)	D12	M8*15(4X)
D29	φ8(4X)	D32	φ8(4X)

Step 4: Removing the first Transport Lock

1. Cut through the transport lock.

► **CAUTION**

Material damage due to incorrect tools

- + Do not use a carpet knife for cutting. Material damage may result.
- + Use safety scissors to release the transport lock.



Step 5: Removing the second Transport Lock

1. Loosen the transport lock (a) on the lower side of the treadmill belt.

Use the Allen key (B05).



Step 6: Attaching the Covers

1. Attach the left and right upright tube cover (C07 & C08) to the side of the treadmill with three bolts (D39) each.

Use the screwdriver (B04).



Step 7: Attaching the EMERGENCY STOP Key

1. Attach the EMERGENCY STOP Key (C19) to the console.

Ensure that all screws are tightened.

→ *The treadmill is now fully assembled.*



Step 8: Alignment of the feet

If the floor is uneven, you can stabilize the treadmill by turning the two setting screws under the main frame.

⚠ WARNING

The treadmill is equipped with high-pressure shock absorbers that can cause the treadmill to suddenly open if handled incorrectly. For more information, refer to the section 2.1 of this manual.

1. Lift the treadmill on the desired side and rotate the setting screws under the main frame.
2. Rotate the screws clockwise in order to remove them and to raise the running surface.
3. Rotate them counterclockwise in order to lower the running surface.

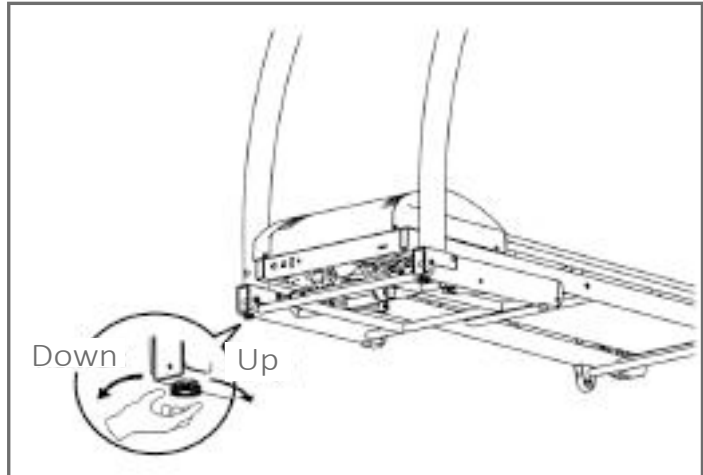

Step 9: Connecting the equipment to the mains supply

► ATTENTION

The equipment must not be connected to a multiple socket, otherwise it cannot be guaranteed that the equipment will be supplied with sufficient power. Technical errors can result.

Plug the power plug into a wall outlet that complies with the instructions in the chapter on electrical safety.

Correctly Getting On and Off

1. To step onto the treadmill, grip the handrails with both hands and step onto the treadmill one foot at a time.
2. To get off, grip the handrails with both hands and step off the treadmill one foot at a time.

3 OPERATING INSTRUCTIONS

NOTICE

- + Familiarise yourself with all the functions and setting options of the device before starting training. Have the proper use of this product explained to you by a specialist.
- + Always start your training with low intensity and increase evenly and gently. End your training with a cool-down phase. If you are unsure, please consult your physician.
- + Most new treadmills make a knocking noise caused by the running mat sliding over the rollers. The time it takes for the noise to subside depends on the intensity of use, the temperature and the humidity around the treadmill.
- + Please bear in mind that the noise emission under load is higher than without load.

SAFETY KEY

WARNING

- + For your safety, the device is equipped with an EMERGENCY STOP function. The equipment can only be operated if the safety key is correctly attached to the contact point of the cockpit. If the safety key is no longer on the contact point, the equipment automatically stops. Therefore, the Safety Key cord with the clip must be attached to your clothing before every training session. If you want to quickly stop the treadmill, if you can no longer control the speed, or if another emergency occurs, remove the safety key from the cockpit using the cord.
- + To enable the safety key to detach from the contact point of the cockpit in the event of a fall, the safety key clip must be firmly attached to your clothing!
- + Make sure that the safety key is not accessible to children.

3.1 Console Display



Knob/button	Function
INSTANT INCLINE	To set the incline, press the shortcut keys 2-10.
INCLINE +	To increase the incline, press this button. The maximum is 15%.
INCLINE -	To reduce the incline, press this button.
HOME	To go to the main page, press this button
START	To start the device, press this button. The speed starts at 0.8 km/h.
INSTANT SPEED	To set the speed, press the shortcut keys 4-12.
SPEED +	To increase the speed, press this button. The maximum is 20 km/h.
SPEED -	To reduce the speed, press this button.
STOP/PAUSE	To pause or stop the training, press this button.
RETURN	To return to the previous page, press this button

3.1.1 Rotary Knob Function

Depending on which mode you are in, the rotary knob has several functions:

- + If you are in standby mode, press the knob to start the treadmill.
- + If you are in workout mode, press the knob to pause the training.

Your data will be kept.

- + Turn the knob to increase or decrease the incline or speed.

The rotary knob indicates which parameter is selected.

- + If you are in standby mode, press the knob to start training.

The speed is set to 0.8 km/h, incline to 0 %.

- + Press and hold the button to pause the treadmill. Press the button again to resume training.
- + Press and hold the button in pause mode to end the training.

Color indicators:

- + Green: 0.8 km/h - 4.9 km/h
- + Blue: 5.0 km/h - 9.9 km/h
- + Red: 10.0 km/h - 20.0 km/h:

3.2 Media Management

The console has two USB ports and a wireless charging station.

USB input 1

- + Connect a mobile device to charge it.

USB input 2:

- + To play your own music and videos on the console, connect a USB stick.

▶ ATTENTION

Do not connect any other mobile device to this input. Damage to the device or the software may be the result.

Wireless charging:

- + Place your mobile phone on the wireless charging station to charge it.



3.3 Applications

The treadmill has several applications that improve your training experience.

1. Tap on the desired application to select it.
2. Tap the icon in the middle of the console to open the application.



NOTICE

Make sure that you are connected to the Internet before using Internet-based applications.

Web:

- + The web application provides an overview of the available apps such as Netflix, YouTube, etc.

Music:

- + The Music application allows you to play music.
- + Displays the music that you have connected via the USB stick.

Movie:

- + The Movie application allows you to play videos.
- + Displays the videos that you have connected via the USB stick.

Settings:

- + Here you will find the settings for WIFI, language settings, admin settings, brightness, unit selection, training entries.

Virtual Active:

- + Simulates a training environment. Choose from various scenes.

HRC:

WARNING

Your training equipment is not a medical device. The heart rate measurement of this equipment may be inaccurate. Various factors can affect the accuracy of the heart rate measurement. The heart rate measurement serves only as a training aid.

- + Here you will find 3 programmes for heart rate-controlled training.

NOTICE

You need a chest strap for this function.

Work out:

- + Here you will find 27 preset training programmes.

User Program:

- + Here you will find user-defined training programmes.
- + You can set, save and retrieve up to 10 user programmes.

NOTICE

Use the menu on the right side of the console to return to the previous page or the home page.

This menu is only displayed within an application.

Use the menu at the bottom of the console to return to the previous page or the start screen.

This menu is only displayed within the settings.

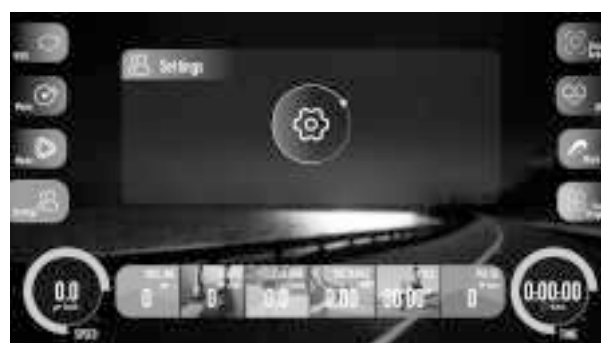

3.4 Workout Programmes

You can choose between 27 different training programmes.

1. Tap on "Work out" in the app selection.

"Work out" is displayed in the centre of the console.

1. Tap on "Work out" in the centre of the screen.

"Work out" is opened.

ⓘ NOTICE

Use the arrow buttons to navigate between the programmes:

ⓘ NOTICE

You can press the buttons for "Incline" and "Speed" at any time during training to change the values.

2. Select one of the 27 programmes. (see chapter 3.4.1 Programmes)

A summary is displayed at the end of a training programme.

3. Exit the summary by tapping the "X" at the bottom right of the screen.

3.4.1 Programmes

The following programmes are available:

Target Time: Target programme for time

1. Set the training time.
2. To start training, tap on "start".

→ *Once the target value has been reached, the training programme ends.*

Target Distance: Target programme for distance

1. Set the distance.
2. To start training, tap "start".

→ *Once the target value has been reached, the training programme ends.*

Target Calorie: Target programme for calories

1. Set the calories.
2. To start training, tap "start".

→ *Once the target value has been reached, the training session ends.*

Cardio test: Test to determine your fitness level

1. Set the time.
2. To start the test, tap on "start".

When the test is complete, an overview of your values is displayed.

① NOTICE

Please note that the test cannot replace a medical examination.

→ *Once the target value has been reached, the training programme ends.*

Hills: Incline programme

1. Set the time.
2. To start the training programme, tap "start".

The programme consists of segments with different incline values.

→ *Once the time has been reached, the training programme ends.*

Fitness: Test to determine your fitness

1. Set the time.
2. To start the test, tap on "start".

When the test is complete, an overview of your values is displayed.

① NOTICE

Please note that the test is not a substitute for a medical examination.

Cross Country: Training programme

1. Set the time.
2. To start the training programme, tap on "start".

The programme consists of several segments with different parameters.

→ *Once the time has been reached, the training programme ends.*

Lose weight: Fat burning programme

1. Set the time.
2. To start the training programme, tap "start".

→ *Once the target value has been reached, the training programme ends.*

Interval training: Interval training programme

1. Set the time.
2. To start the training programme, tap "start".

The programme consists of several segments with different intensities.

→ *Once the time has been reached, the training programme ends.*

Speed Drill: Training programme

1. Set the time.
2. To start the training programme, tap "start".

The programme consists of several segments with different intensities.

→ *Once the time has been reached, the training programme ends.*

Hill and Back: Training programme

1. Set the time.
2. To start the training programme, tap "start".

The programme consists of several segments with different intensities.

→ *Once the time has been reached, the training programme ends.*

Power Walk: Training programme

1. Set the time.
2. To start the training programme, tap "start".

The programme consists of several segments with different intensities.

→ *Once the time has been reached, the training programme ends.*

Pyramid: Training programme

1. Set the time.
2. To start the training programme, tap "start".

The programme consists of several segments with different intensities.

→ *Once the time has been reached, the training programme ends.*

Glute workout: Training programme for the gluteal muscles

1. Set the time.
2. To start the training programme, tap "start".

The programme consists of several segments with different intensities.

→ *Once the time has been reached, the training programme ends.*

Calorie Burn: Training programme for burning calories

1. Set the time.
2. To start the training programme, tap "start".

The programme consists of several segments with different intensities.

→ *Once the time has been reached, the training programme ends.*

Special Training-1: Run against a virtual opponent

1. Set the time.
2. To start the training programme, tap "start".

The programme consists of several segments with different intensities.

→ *Once the distance has been reached, the training session ends.*

Special Training-2: Run against a virtual opponent

1. Set the time.
2. To start the training programme, tap "start".

The programme consists of several segments with different intensities.

→ *Once the distance has been reached, the training session ends.*

Special Training-3: Run against a virtual opponent

1. Set the time.
2. To start the training programme, tap "start".

The programme consists of several segments with different intensities.

→ *Once the distance has been reached, the training session ends.*

International Competition-1: Run against a virtual opponent

1. Set the time.
2. To start the training programme, tap "start".

The programme consists of several segments with different intensities.

→ *Once the distance has been reached, the training session ends.*

International Competition-2: Run against a virtual opponent

1. Set the time.
2. To start the training programme, tap "start".

The programme consists of several segments with different intensities.

→ *Once the distance has been reached, the training session ends.*

International Competition-3: Run against a virtual opponent

1. Set the time.
2. To start the training programme, tap "start".

The programme consists of several segments with different intensities.

→ *Once the distance has been reached, the training session ends.*

Professional Game-1: Run against a virtual opponent

1. Set the time.
2. To start the training programme, tap "start".

The programme consists of several segments with different intensities.

→ *Once the distance has been reached, the training session ends.*

Professional Game-2: Run against a virtual opponent

1. Set the time.
2. To start the training programme, tap "start".

The programme consists of several segments with different intensities.

→ *Once the distance has been reached, the training session ends.*

Professional Game-3: Run against a virtual opponent

1. Set the time.
2. To start the training programme, tap "start".

The programme consists of several segments with different intensities.

→ *Once the distance has been reached, the training session ends.*

Outdoor Running-1: Run against a virtual opponent

1. Set the time.
2. To start the training programme, tap "start".

The programme consists of several segments with different intensities.

→ *Once the distance has been reached, the training session ends.*

Outdoor Running-2: Run against a virtual opponent

1. Set the time.
2. To start the training programme, tap "start".

The programme consists of several segments with different intensities.

→ *Once the distance has been reached, the training session ends.*

Outdoor Running-3: Run against a virtual opponent

1. Set the time.
2. To start the training programme, tap "start".

The programme consists of several segments with different intensities.

→ *Once the distance has been reached, the training session ends.*

3.5 User-defined Programmes

You have the option of saving up to ten user-defined programmes..

1. Tap on "User Program" in the app selection.

"User Program" is displayed in the centre of the console.

2. Tap on "User Program" in the centre of the screen.

"User Programme" is opened.

3. Set the desired parameters: Time, incline, speed.
4. To start the training programme, tap "start".

The training starts.

① NOTICE

Incline and speed can be changed during training.

Once the segments are passed, the training is finished.

→ *A training overview will be displayed.*

5. Exit the overview by tapping on the "X" at the bottom right of the screen.

3.6 Hand Pulse Sensors

The treadmill has hand pulse sensors that display your pulse during training.

① NOTICE

This only works if both hand pulse sensors are gripped.

3.7 Lubrication Reminder Function

The treadmill has a reminder function that reminds you to lubricate the treadmill after 300 kilometres.

NOTICE

After you have lubricated the treadmill, press the "Stop" button for three seconds.

→ *The lubrication reminder disappears.*

3.8 Saving Energy

The treadmill switches to standby mode after ten minutes of inactivity.

① NOTICE

A message appears before the treadmill switches to standby mode.

3.9 Power Switch

The on/off switch is located on the back of the treadmill.

① NOTICE

Switch the treadmill off if you are not using it for a longer period of time.

3.10 Wireless Connection and Fitness Apps

This console is equipped with a wireless connection interface. Please take note that your mobile device needs to be compatible with the wireless connection interface of the treadmill.

To use training apps you will have to activate the wireless connection function on your mobile device (tablet or smart phone) and start the fitness app. Select your fitness equipment. Please follow the instructions given in the app. You will find the name of your fitness equipment on a small sticker on the back of the console.

You will find the fitness apps in the app stores of Google or Apple. There you will find the apps "Kinomap" or "Zwift". Please note that these apps are produced by an external manufacturer. Fitshop does not take any responsibility regarding the availability, functionality or contents of these programmes.

IMPORTANT NOTE

The pre-installed apps are produced and provided by external manufacturers. Changes and availability within these apps might occur. Fitshop does not take any responsibility and can not be held liable for the availability, functionality or contents of these apps. To make sure the pre-installed apps are working correctly, they must be updated regularly. If needed, the respective app will notify you to do so. To update the app, you need a google account. A google email is sufficient. Just follow the instructions on the screen to perform the update.

Please note: The system is set up only for the pre-installed apps. Do not install any additional apps as their proper functionality can not be guaranteed. The installation of other apps might cause technical issues.



Example: Kinomap

4.1 General Instructions

WARNING

- + The storage location should be chosen so that improper use by third parties or children can be prevented.
- + If your equipment does not have transportation wheels, the equipment must be disassembled before transportation.

ATTENTION

- + Make sure that the equipment is protected from moisture, dust and dirt in the selected storage location. The storage location should be dry and well ventilated and have a constant ambient temperature between 10°C and 35°C.

4.2 Transportation Wheels

ATTENTION

If you want to transport your equipment over particularly sensitive and soft floor coverings, such as parquet, planks or laminate, lay out the transport route with cardboard or similar to avoid possible floor damage.

1. Stand behind the equipment and lift it until the weight is transferred to the transportation wheels. After that, you easily can move the equipment to a new position. For long transport distances the equipment should be disassembled and safely packed.
2. Select the new location by following the instructions in the section 1.4 of this manual.

4.3 Folding Mechanism

WARNING

- + The treadmill is equipped with high-pressure shock absorbers that can cause the treadmill to suddenly open if handled incorrectly. For more information, refer to the section 2.1 of this manual.
- + Do not lift the treadmill by the running mat or the rear transporting wheels. These parts do not lock and are difficult to grab.

NOTICE

The treadmill is foldable and thus saves space when it is stored. It also makes it easier to transport.

4.3.1 Folding Up the Treadmill

⚠ WARNING

- + Do not connect the equipment to the power supply when it is folded up. Try not to operate the equipment when it is folded up.
- + The running surface must have come to a complete stop before folding.

⚠ CAUTION

- + Do not lean on the equipment when it is folded and do not place anything on top of it that may make the equipment unstable or fall down.

▶ ATTENTION

- + Make sure that nothing is standing next to or on top of the treadmill that can be spilled or thrown or that makes it impossible to fold the treadmill.

1. Turn off the on/off switch and remove the plug from the outlet.
2. Use both hands to grab the supportive bar directly under the rear part of the running mat so that you have a stable lifting point.
3. Make sure that the hydraulic brake is correctly locked and tilt the treadmill forward.
4. Make sure that you are standing safely and make sure that the locking mechanism is secure by pulling the equipment backwards and it does not move.

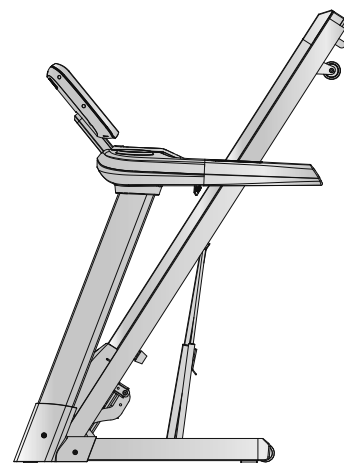

4.3.2 Unfolding the Treadmill

▶ ATTENTION

- + Make sure that nothing is standing next to or on top of the treadmill that can be spilled or thrown or that makes it impossible to unfold the treadmill.

1. Stand behind the treadmill and push the device slightly forward towards the display.
2. To release the hydraulic brake lock, use your left foot to push the upper part of the hydraulic brake slightly forward until the lock releases and the treadmill can be pulled back.
3. Keep holding the treadmill.

The hydraulic brake lowers itself gently downwards.

4. Once the treadmill has lowered $\frac{2}{3}$, you can let go of the treadmill.

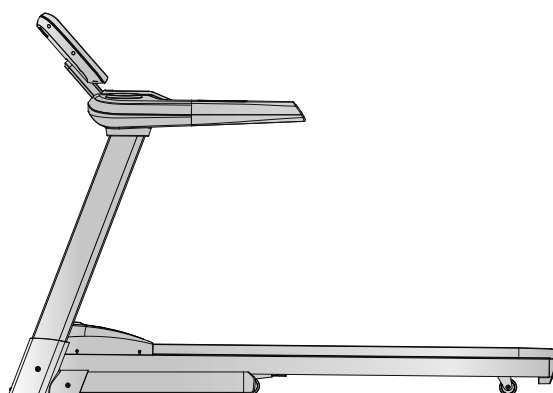

5.1 General Instructions

⚠ WARNING

- + Do not make any improper changes to the equipment.

⚠ CAUTION

- + Damaged or worn components may affect your safety and the life of the equipment. Therefore, immediately replace damaged or worn components. In such a case, contact the contract partner. The equipment must not be used until it has been repaired. If necessary, use only original spare parts.

▶ ATTENTION

- + In addition to the instructions and recommendations for maintenance and care given here, additional service and/or repair work may be necessary; this must only be carried out by authorised service technicians.

5.2 Faults and Fault Diagnosis

The equipment undergoes regular quality controls during production. Nevertheless, faults or malfunctions may occur. Frequently, individual parts are responsible for these disturbances, an exchange is usually sufficient. Please refer to the following overview for the most common errors and how to correct them. If the equipment still does not function properly, contact your contract partner.

Fault	Cause	Solution
Console is not responding	Safety key missing or not inserted correctly	Check whether Safety Key is inserted and insert if necessary
Running mat slanting	Running mat not centered	Adjust the running mat according to the instructions
Grinding noises		
Running mat slips through/stops	Tape tension/lubrication not correct	Check belt tension/lubrication according to instructions
Display is blank/is not working	+ Interrupted power connection + Loose cabel connections	+ Power switch to on + Check whether Safety Key is plugged in + Check cable connections
No pulse display	+ Sources of interference in the room + unsuitable chest strap + Wrong position of chest strap + Chest strap defective or battery empty + Pulse display defective	+ Eliminate sources of interference (e.g. mobile phone, WLAN, lawn mower and vacuum cleaner robot, etc. ...) + Use a suitable chest strap (see RECOMMENDED ACCESSORIES). + Reposition chest strap and/or moisten electrodes + Changing batteries + Check if pulse display by hand pulse possible

5.3 Error Codes and Troubleshooting

The electronics of the equipment continuously carries out tests. In case of deviations, an error code appears on the display and normal operation is stopped for your safety.

Please contact the contract partner for technical support.

5.4 Care and Maintenance

The most important maintenance measure is the care of the running mat. This includes adjustment, re tensioning and lubrication of the running mat. Damage resulting from insufficient or neglected care is not covered by the warranty. You should therefore carry out maintenance checks at regular intervals. Be very careful when adjusting and tightening the running mat, as a strong over voltage or under voltage can cause damage to the equipment. The running mat is adjusted at the factory according to the regulations before delivery. However, it may happen that the running mat slips during transport.

By scanning the QR-code with the camera function or QR-code scanner app of your smartphone/tablet, a video on general maintenance of a treadmill opens on YouTube. The video serves to illustrate the maintenance points described in this manual.



Please note that the video may not be available in your language or with appropriate subtitles.

If you cannot scan QR-codes, you can access all Fitshop videos on YouTube by first opening YouTube and entering "Fitshop" in the search field.

5.4.1 Adjusting the Running Mat

During training, the running mat should run as centrally and straight as possible. The alignment of the running mat can change depending on the stress and load. Another reason can be the positioning of the equipment on an uneven surface.

CAUTION

During the following maintenance nobody must be on the treadmill!

1. Let the treadmill run at a speed of 5 km/h.
2. If the running mat deviates to the left, turn the left adjusting screw at the rear end of the device max. one $\frac{1}{4}$ turn clockwise and the right adjusting screw max. one $\frac{1}{4}$ turn anticlockwise.
3. If the running mat deviates to the right, turn the right adjusting screw at the rear end of the device max. $\frac{1}{4}$ turn clockwise and the left adjusting screw max. $\frac{1}{4}$ turn anticlockwise.
4. Then observe the mat for about 30 seconds, as the change is not immediately visible.
5. Repeat this procedure until the running mat is straight again. If the running mat cannot be adjusted, please contact your contract partner.

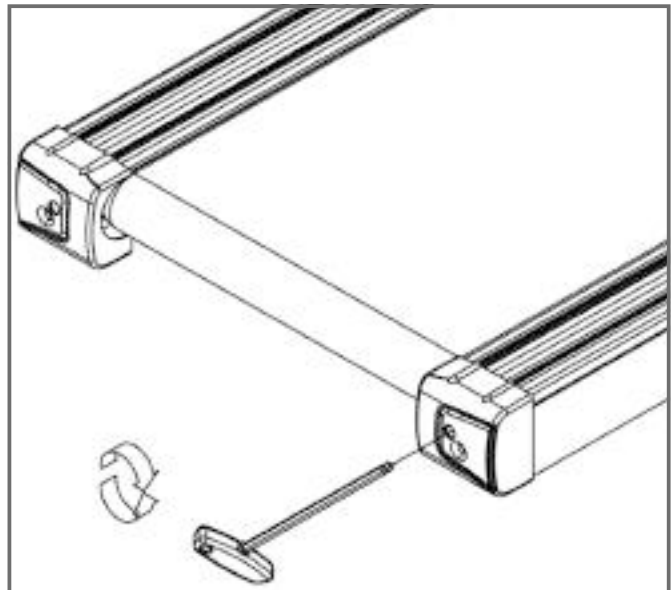

5.4.2 Re-tensioning the Running Mat

If the running mat slips over the rollers during operation (if this is the case, there is a noticeable jerk during running), the running mat must be re-tightened.

In most cases, the slipping is caused by stretching of the mat through use. This is perfectly normal.

① NOTICE

Re-tensioning is carried out using the same adjusting screws that are used for adjustment.

1. Let the treadmill run at a speed of 5km/h.
2. Turn the left and right adjusting screws directly one after the other, max. one ¼ turn clockwise.
3. Then check whether the running mat continues to slip. If this is the case, you must perform the described procedure again.

5.4.3 Lubricating the Running Mat

If the running mat is not sufficiently lubricated, friction increases significantly and this leads to heavy wear of the endless belt, running plate, motor and circuit board. If you feel an increased friction of the running mat, this is an indication that you should lubricate the mat. However, lubrication should be carried out at least every 3 months or every 50 operating hours. Whichever case comes first.

① NOTICE

If your treadmill is equipped with a folding mechanism, you can also lubricate it when it is folded.

1. Raise the running mat slightly.
2. Apply some silicone oil or silicone spray to the entire deck and distribute evenly.
3. Continue turning the belt by hand so that the entire surface between the endless belt and the running plate is lubricated.
4. Wipe off the excess silicone oil or silicone spray.

① NOTICE

This maintenance must also be carried out after prolonged non-use of the equipment.

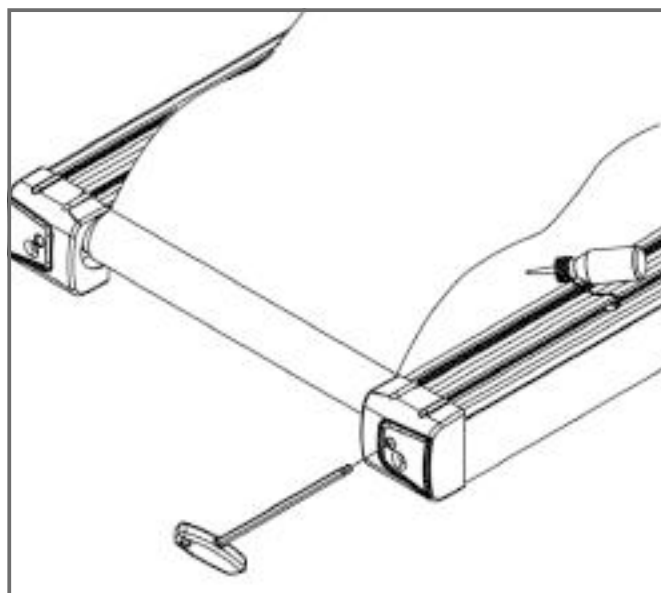

5.5 Maintenance and Inspection Calendar

To avoid damage from body sweat, the equipment must be cleaned with a damp towel (no solvents!) after each training session.

The following routine tasks must be performed at the specified intervals:

Part	Weekly	Monthly	Quarterly
Display console	C	I	
Tension of the running mat			I
Lubrication of the running mat			I
Plastic covers	C	I	
Screws and cable connections			I
Legend: C = clean; I = inspect			

By scanning the QR-code with the camera function or QR-code scanner app of your smartphone/tablet, a video on general maintenance of a treadmill opens on YouTube. The video serves to illustrate the maintenance points described in this manual.

Please note that the video may not be available in your language or with appropriate subtitles.

If you cannot scan QR-codes, you can access all Fitshop videos on YouTube by first opening YouTube and entering "Fitshop" in the search field.



6 DISPOSAL

At the end of its operational life, this equipment cannot be disposed of in normal household waste. Instead, it must be disposed of via an electricals recycling centre. Further information can be obtained from your local authority's recycling service.



The materials can be recycled as per their symbols. Through the reuse, recycling of materials or other forms of recovery of old equipment, you make an important contribution to the protection of the environment.

7 RECOMMENDED ACCESSORIES

To make your training experience even more efficient and pleasant, we recommend that you add suiting accessories to your fitness equipment. For treadmills this could for example be a **floor mat**, which makes your fitness equipment stand more securely and also protects the floor from sweat or **silicone spray** to keep moving parts in good shape and lubricate the running mat. Furthermore, there are additional **handrails** available for some treadmills.

If you have purchased a fitness machine with pulse training and want to train your heart rate, we strongly recommend that you use a compatible **chest strap**, as this ensures optimum transmission of the heart rate.

Our range of accessories offers the highest quality and makes training even better. If you would like to find out more about compatible accessories, please go to the detail page of the product in our webshop (the easiest way is to enter the article number in the search field above) and go to the recommended accessories on this page. Of course, you can also contact our customer service: by telephone, e-mail, in one of our branches or via our social media channels. We will be happy to advise you!



floor mat



chest strap



handrails



lubricant

8.1 Serial Number and Model Name

In order to provide you with the best possible service, please have the model name, article number, serial number, exploded drawing and parts list ready. The corresponding contact options can be found in chapter 10 of this operating manual.

NOTICE

The serial number of your equipment is unique. It's located on a white sticker. The exact position of this sticker is shown in the following illustration.

Enter the serial number in the appropriate field.

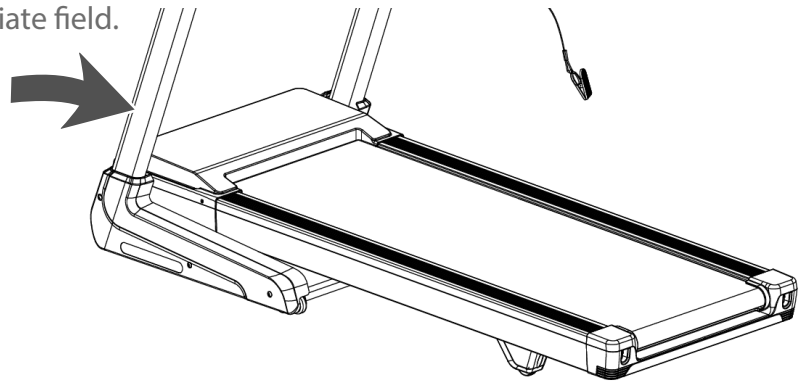

Serial number:

Brand / Category:

Model Name:

SKU:

8.2 Parts List

No.	Name	Specification	Qty.
A01	Base frame		1
A02	Main frame		1
A03	Incline bracket		1
A04	Console base bracket		1
A05	Panel connecting bracket		1
A06	Left upright tube		1
A07	Right upright tube		1
A08	Panel turning fixed bracket		1
B01	Pulse steel plate		4
B02	Back roller		1
B03	Pipe		2
B04	Wrench w/screw driver	S=13, 14, 15	1
B05	5# Allen wrench	5mm	1
B06	6# Allen wrench	6mm	1
B07	Cylinder		1
B08	Front roller		1
B09	Sleeve		2
B10	Spring plate		2
B11	Speaker net		2
C01	Motor top cover		1
C02	Motor bottom cover		1
C03	Back end cover		1
C04	Adjustable wheel cover		2
C05	Side rail		2
C06	Panel turning sleeve		2
C07	Left upright tube cover		1
C08	Right upright tube cover		1
C09	Console top cover		1
C10	Console bottom cover		1
C11	Console left side cover		1
C12	Console right side cover		1

C13	Left handle bar		1
C14	Right handle bar		1
C15	Console cover adapter block		4
C16	Panel top cover		1
C17	Panel bottom cover		1
C18	Holder		1
C19	Safety key clip		1
C20	Side rail tension seat		8
C21	Running belt		1
C22	Cushion		4
C23	Cushion		4
C24	Wheel		2
C25	Adjustable wheel		2
C26	Plastic gasket		4
C27	Ring protective plug		2
C28	Foot pad		2
C29	Cylindrical cushion		2
C30	Adjustable foot pad		2
C31	Safety key base		1
C32	Safety key		1
C33	Motor belt		1
C34	EVA pad		2
C35	EVA pad		1
C36	Rubber cushion		2
C37	Square pipe plug		1
C38	EVA pad		1
C39	Knob fixed base		4
C40	Water bottle pad		2
D01	Nut	M6	1
D02	Nut	M8	14
D03	Nut	M10	6
D04	Bolt	M10*90	1
D05	Bolt	M10*45	1
D06	Bolt	M10*30	2

D07	Bolt	M8*50	6
D09	Bolt	M8*45	1
D10	Bolt	M8*30	1
D11	Bolt	M8*15	4
D12	Bolt	M8*15	6
D13	Bolt	M8*65	2
D14	Bolt	M6*60	1
D15	Bolt	M8*40	2
D16	Bolt	M6*15	2
D17	Bolt	M6*12	4
D18	Bolt	M8*25	4
D19	Bolt	M5*16	6
D20	Bolt	M5*12	8
D21	Screw	ST2.9*8	2
D22	Screw	ST4.2*10	22
D23	Screw	ST4.2*12	17
D24	Screw	ST4.2*12	51
D25	Screw	ST2.9*8	47
D26	Lock washer	10	2
D27	Lock washer	6	1
D28	Lock washer	8	12
D29	Spring washer	8	6
D30	Big washer	"φ10*φ 26*2.0"	6
D31	Screw	ST4.2*20	4
D32	Flat washer	8	14
D33	Screw	ST2.0*6	4
D34	Bolt	M10*3	2
D35	Screw	ST2.9*16	3
D36	Lock washer	5	2
D37	Spring washer	5	2
D38	Screw	ST4.2*30	4
D39	Bolt	M5*10	6
E01	DC motor		1
E02	Incline motor		1

E03	Switch on-off		1
E04	Power socket		1
E05	Overload protector		1
E06	Magnetic ring		1
E07	Magnetic core		1
E08	Power wire		1
E09	AC signal wire	200 brown	1
E10	AC signal wire	350 brown	2
E11	AC signal wire	350 blue	2
E12	Ground wire		1
E13	Running board		1
E14	Console		1
E15	Control board		1
E16	Left touch button board		1
E17	Right touch button board		1
E18	Switch knob		1
E19	Console top signal wire		1
E20	Console middle signal wire		1
E21	Console bottom signal wire		1
E22	Hand pulse top signal wire		1
E23	Hand pulse bottom signal wire		2
E24	Safety switch induction wire 1		1
E25	Safety switch induction wire 2		1
E26	Touch button connecting wire		1
E27	Speaker		2
E28	Switch knob top signal wire		1
E29	Switch knob bottom signal wire		1
E30	Touch button top signal wire		1
E31	Touch button bottom signal wire		1
E32	AC signal wire	Red	1
E33	AC signal wire	Black	1
E34	Console wire 1		1
E35	Console wire 2		1
E36	Low-power board		1

C	Console set		1
C-1	Console Overlay		1
B-1	Left button overlay (incline)		1
B-2	Right button overlay (speed)		1
F01	Filter		1
F02	Inductance		1
F03	AC signal wire (L 350)		1
F04	Ground wire (L 350)		1
F05	Screw	ST4.2*12	4
G01	Wireless charging adapter board		1
G02	Wireless charging adapter board wire		1
G03	Screw		4
H01	Wireless pulse connecting wire		1
H02	POLAR wireless receiver		1
J01	USB module		1
J02	USB connecting wire		1
J03	USB charging wire		1

8.3 Exploded Drawing

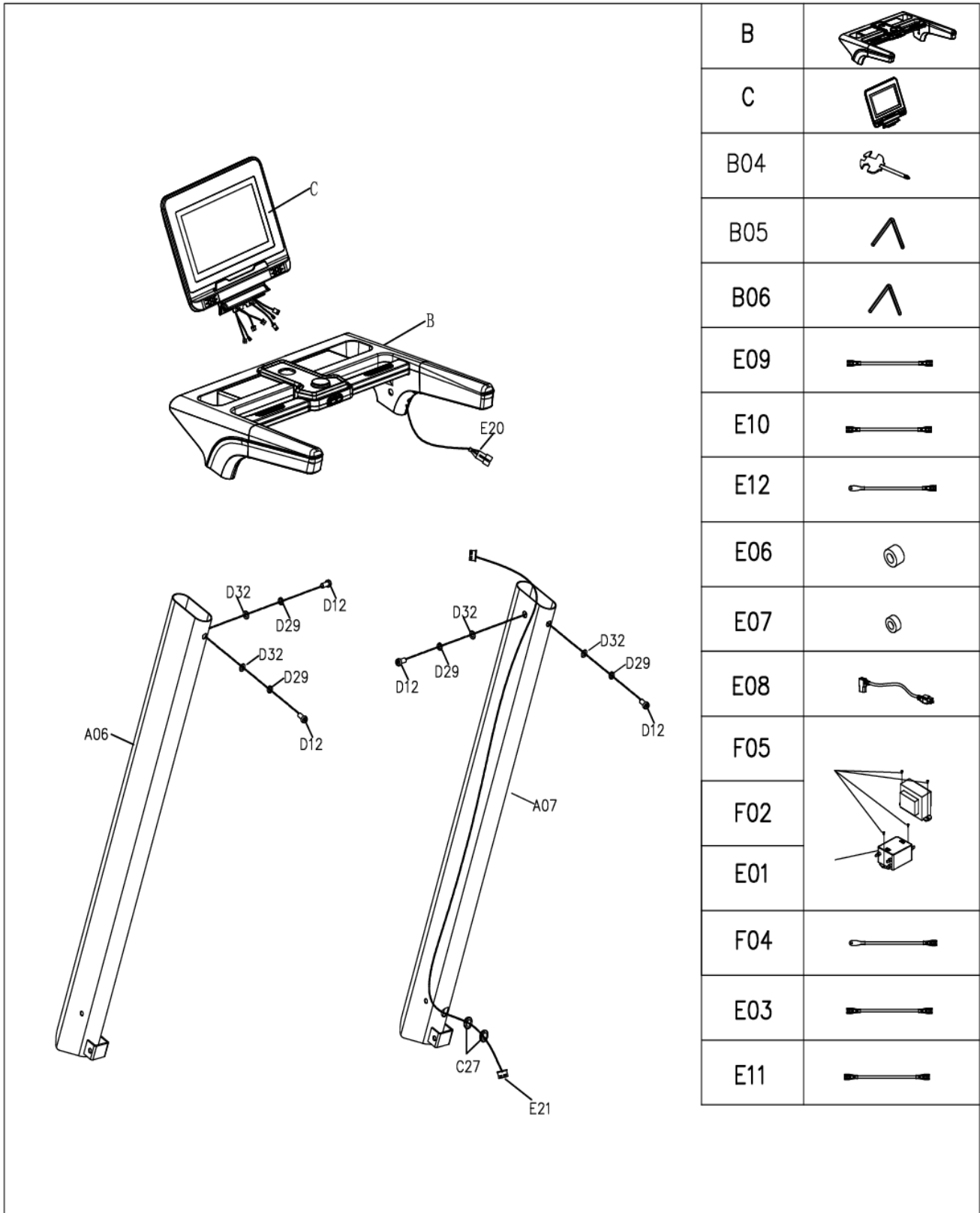

B	
C	
B04	
B05	
B06	
E09	
E10	
E12	
E06	
E07	
E08	
F05	
F02	
E01	
F04	
E03	
E11	

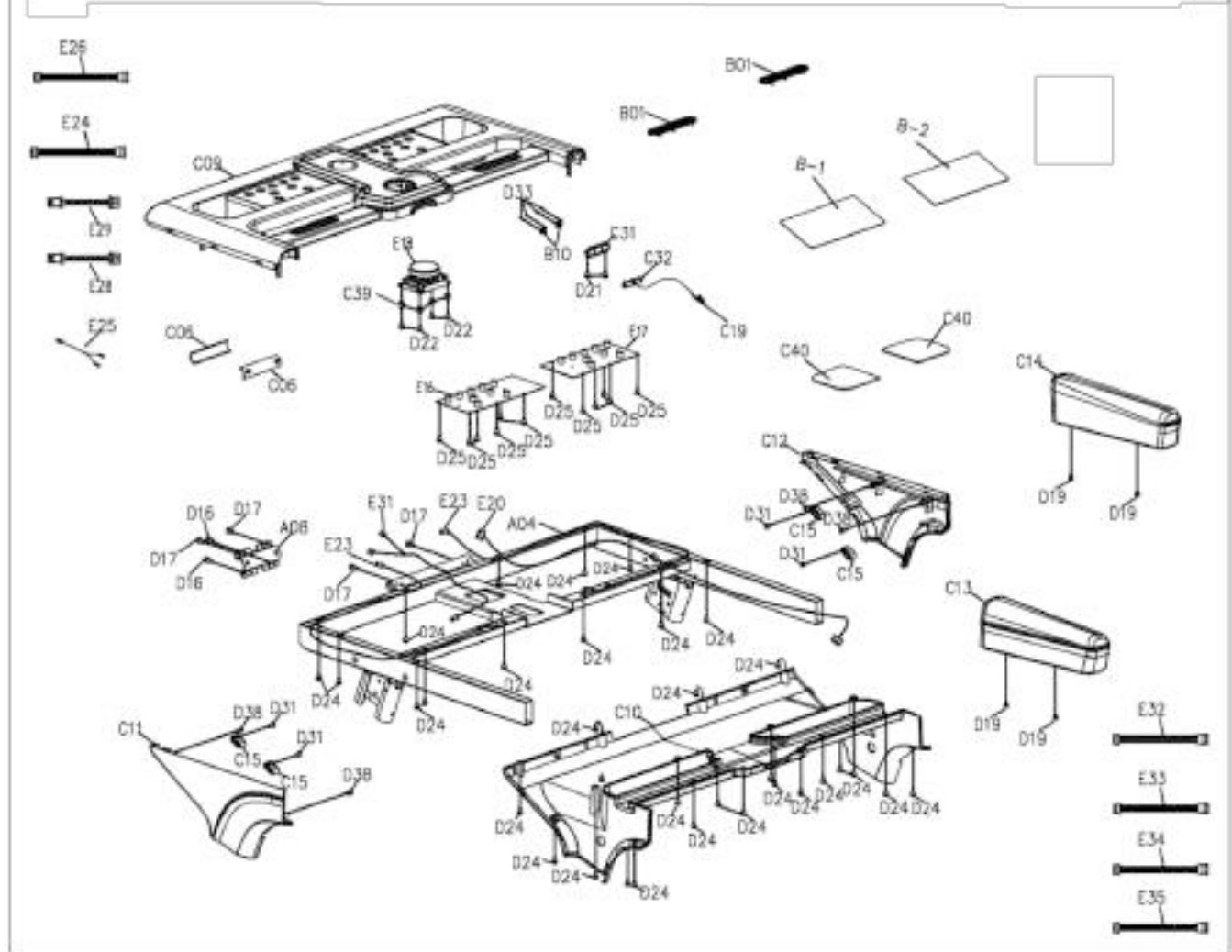
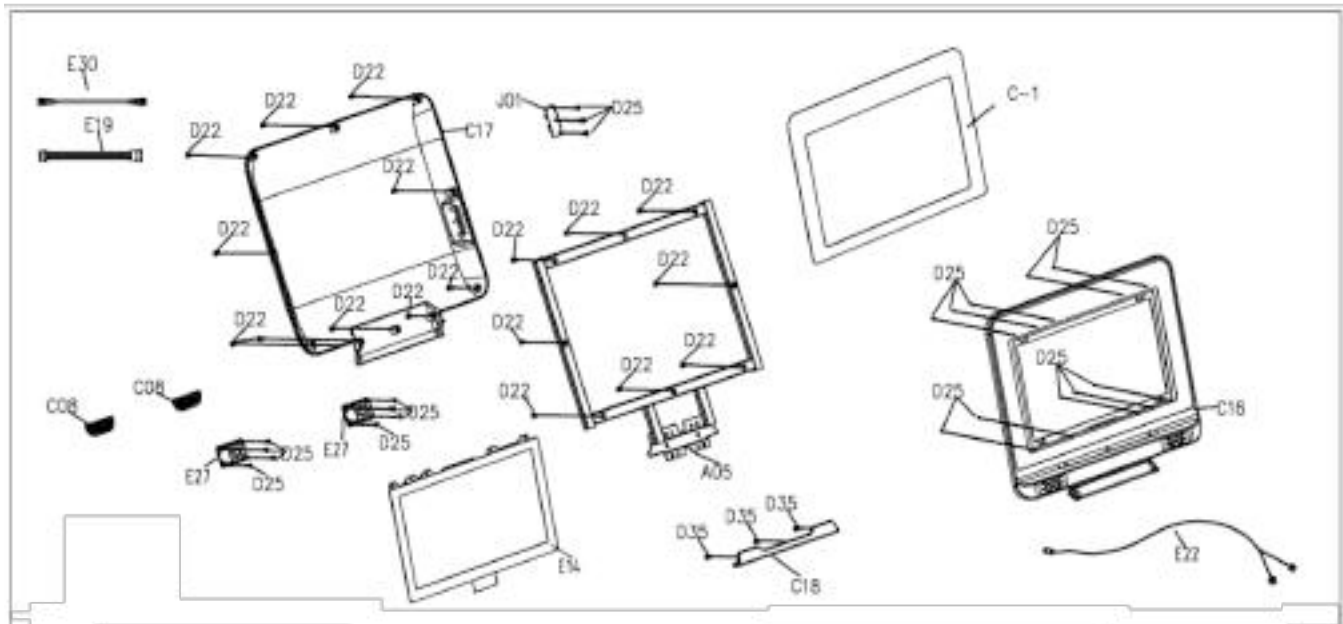

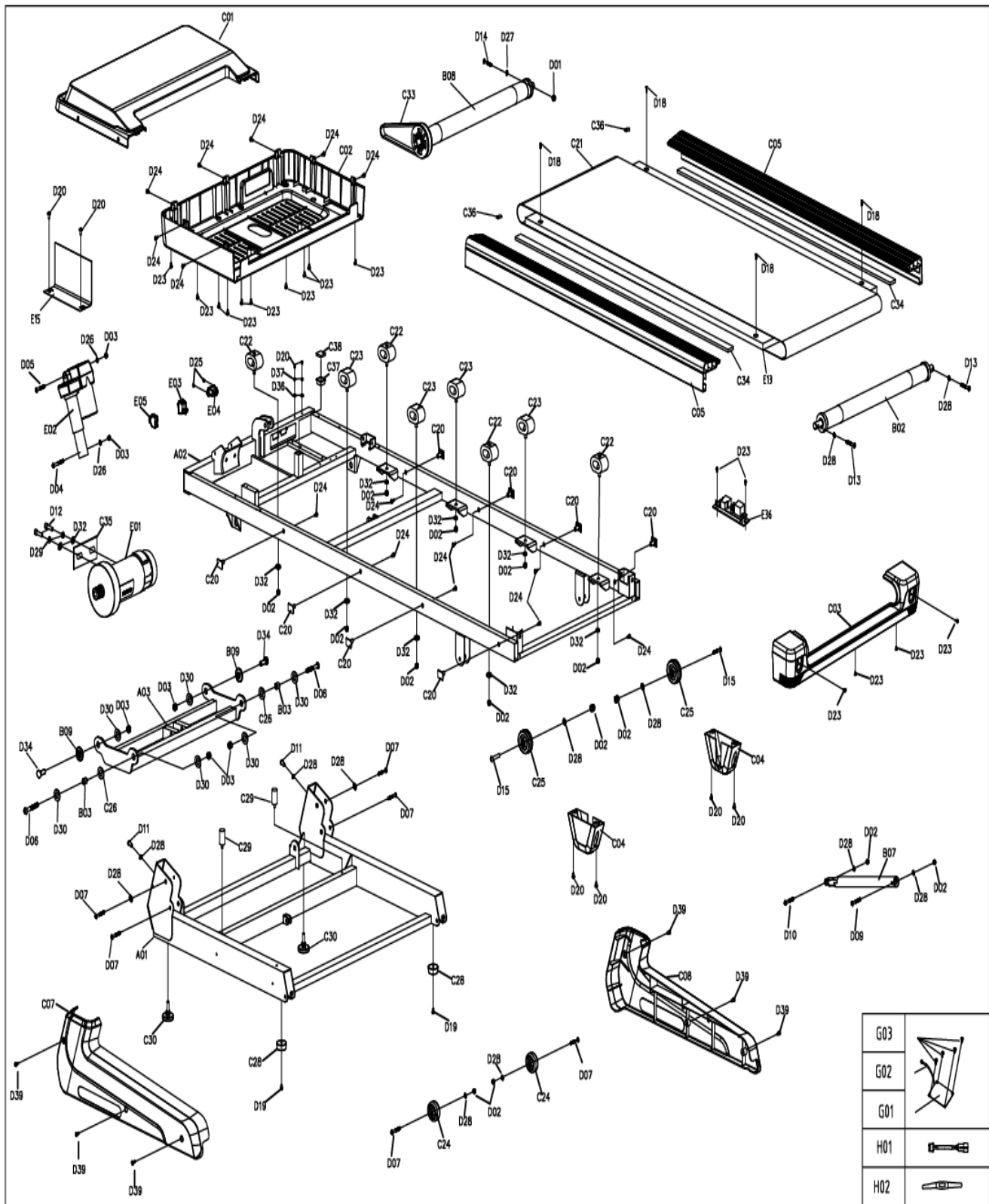

Products from cardiostrong® are subject to strict quality control. However, if a fitness equipment purchased from us does not work perfectly, we take it very seriously and ask you to contact our customer service as indicated. We are happy to help you by phone via our service hotline.

Error Descriptions

Your fitness equipment is developed for long-term, high-quality training. However, should a problem arise, please first read the operating instructions. For further assistance, please contact your contract partner or call our service hotline. To ensure your problem is solved as quickly as possible, please describe the defect as exactly as possible.

In addition to the statutory warranty, we provide a warranty for every fitness equipment purchased from us according to the following provisions.

Your statutory rights are not affected.

Warrantee

The warrantee is the first/original buyer.

Warranty periods

The following warranty periods begin on delivery of the fitness equipment.

Warranty period

The warranty periods, shown on our web shop, begin on delivery of the fitness equipment. The respective warranty periods for your equipment can be found on its product website.

Repair Costs

According to our choice, there will either be a repair, a replacement of individual damaged parts or a complete replacement. Spare parts, that have to be mounted while assembling the equipment, have to be replaced by the warrantee personally and are not a part of repair. After the expiration of the warranty period, the responsibility for parts costs, repair costs, installation costs and delivery costs lies with the warranty holder.

The terms of use are defined as follows:

- + Home use: solely for private use in private households up to 3 hours per day
- + Semi-professional use: up to 6 hours per day (e. g. rehabilitation centres, hotels, clubs, company gyms)
- + Professional use: more than 6 hours per day (e. g. commercial gyms)

Warranty Service

Within the warranty period, equipment which develops faults as a result of material or manufacturing defects, will be repaired or replaced at our discretion. Ownership of equipment or parts of equipment which have been replaced is transferred to us. The warranty period is not extended nor does a new warranty period begin following repair or replacement under the warranty.

Warranty Conditions

For the warranty to be valid, the following steps must be taken:

Please contact our customer service by email or phone. If the product under warranty has to be sent in for repair, the seller bears costs. After expiry of the warranty, the buyer bears the costs of transport and insurance. If the fault is covered by our warranty, you will receive a new or repaired equipment in return.

Warranty claims are invalid in case of damage resulting from:

- + misuse or improper handling
- + environmental influences (moisture, heat, electrical surge, dust, etc.)
- + failure to follow the current safety measures for the equipment
- + failure to follow the operating instructions
- + use of force (e. g. hitting, kicking, falling)
- + interventions which were not carried out by one of our authorized service centres
- + unauthorised repair attempts

Proof of Purchase and Serial Number

Please make sure that you are able to provide the appropriate receipt when claiming on your warranty. So that we can clearly identify the model of your equipment, and for the purposes of our quality control, you will need to give the serial number of your equipment, when contacting the service team. Where possible please have your serial number and your customer number ready when you call our service hotline. It will help us to deal with your request swiftly.

If you cannot find the serial number on your fitness equipment, our service team is at your disposal to offer further information.

Service outside of the Warranty Period

We are also happy to issue an individual cost estimate if there is a problem with your fitness equipment after the warranty has expired, or in cases which do not fall under the terms of the warranty, e. g. normal wear and tear. Please contact our customer service team to find a quick and cost-effective solution to your problem. In such a case you will be responsible for the delivery costs.

Communication

Many problems can be solved just by speaking to us as your specialist supplier. We know how important it is to you as a user of the fitness equipment to have problems solved quickly and simply, so you can enjoy working out with minimal interruption. For that reason, we also want to resolve your queries quickly and in a straightforward manner. Thus, please always keep your customer number and the serial number of the faulty equipment handy.

10 CONTACT

DE	DK	UK
<p>TECHNIK</p> <p>☎ +49 4621 4210-900 📄 +49 4621 4210-698 📧 technik@fitshop.de 🕒 Öffnungszeiten entnehmen Sie unserer Homepage.</p> <p>SERVICE</p> <p>☎ 0800 20 20277 (kostenlos) ☎ 04621 4210 - 0 📧 info@fitshop.de 🕒 Öffnungszeiten entnehmen Sie unserer Homepage: https://stg.fit/statita</p>	<p>TEKNIK OG SERVICE</p> <p>☎ 80 90 16 50 +49 4621 4210-945 📧 info@fitshop.dk 🕒 Åbningstider kan findes på hjemmesiden: https://stg.fit/statit7</p>	<p>CUSTOMER CARE</p> <p>☎ +44 141 737 2249 or +44 141 876 3972 📧 customercare@fitshop.co.uk 🕒 You can find the opening hours on our homepage: https://stg.fit/statitd</p>
	FR	BE
	<p>TECHNIQUE & SERVICE</p> <p>☎ +33 (0) 189 530984 +49 4621 42 10 933 📧 info@fitshop.fr 🕒 Vous trouverez les heures d'ouverture sur notre site Internet: https://stg.fit/statit4</p>	<p>TECHNIQUE & SERVICE</p> <p>☎ 02 732 46 77 +49 4621 4210 933 📧 info@fitshop.be 🕒 Vous trouverez les heures d'ouverture sur notre site Internet: https://stg.fit/statit8</p>
ES	NL	INT
<p>TECNOLOGÍA Y SERVICIOS</p> <p>☎ 911 238 029 📧 info@fitshop.es 🕒 Consulta nuestro horario de apertura en la página web: https://stg.fit/statit5</p>	<p>TECHNISCHE DIENST & SERVICE</p> <p>☎ +31 172 619961 📧 service@fitshop.nl 🕒 De openingstijden vindt u op onze homepage: https://stg.fit/statit3</p>	<p>TECHNICAL SUPPORT & SERVICE</p> <p>☎ +49 4621 4210-944 📧 service-int@fitshop.de 🕒 You can find the opening hours on our homepage: https://stg.fit/statita</p>
PL	AT	CH
<p>DZIAŁ TECHNICZNY I SERWIS</p> <p>☎ 22 307 43 21 +49 4621 42 10-948 📧 info@fitshop.pl 🕒 Godziny otwarcia można znaleźć na stronie głównej: https://stg.fit/statit6</p>	<p>TECHNIK & SERVICE</p> <p>☎ 0800 20 20277 (Freecall) +49 4621 42 10-0 📧 info@fitshop.at 🕒 Öffnungszeiten entnehmen Sie unserer Homepage: https://stg.fit/statitb</p>	<p>TECHNIK & SERVICE</p> <p>☎ 0800 202 027 +49 4621 42 10-0 📧 info@fitshop.ch 🕒 Öffnungszeiten entnehmen Sie unserer Homepage: https://stg.fit/statit9</p>

Please find a detailed overview including address and opening hours for all stores of Fitshop UK on the following website:

www.fitshop.co.uk/storelocator

WE LIVE FITNESS

WEBSHOP AND SOCIAL MEDIA

The Fitshop Group is Europe's largest specialist for home fitness equipment with currently 70 stores and one of the world's most renowned online mail order companies for fitness equipment.

Fitshop UK is part of the Fitshop Group. Private customers order via the 25 web shops in the respective national language or have their desired equipment assembled on site. In addition, the company supplies fitness studios, hotels, sports clubs, companies and physio practices with professional equipment for endurance and strength training.

The Fitshop group offers a wide range of fitness equipment from renowned manufacturers, high-quality in-house developments and comprehensive services, such as a build-up service and sports scientific advice before and after the purchase. The company employs numerous sports scientists, fitness trainers and competitive athletes.

Visit us also on our social media platforms or our blog!



<https://www.fitshop.co.uk>
www.fitshop.co.uk/blog



www.facebook.com/fitshop.co.uk



www.instagram.com/fitshop_uk



www.youtube.com/@fitshop_uk

TAURUS

 cardiostrong 

BODYCRAFT

BodyMax

Notes

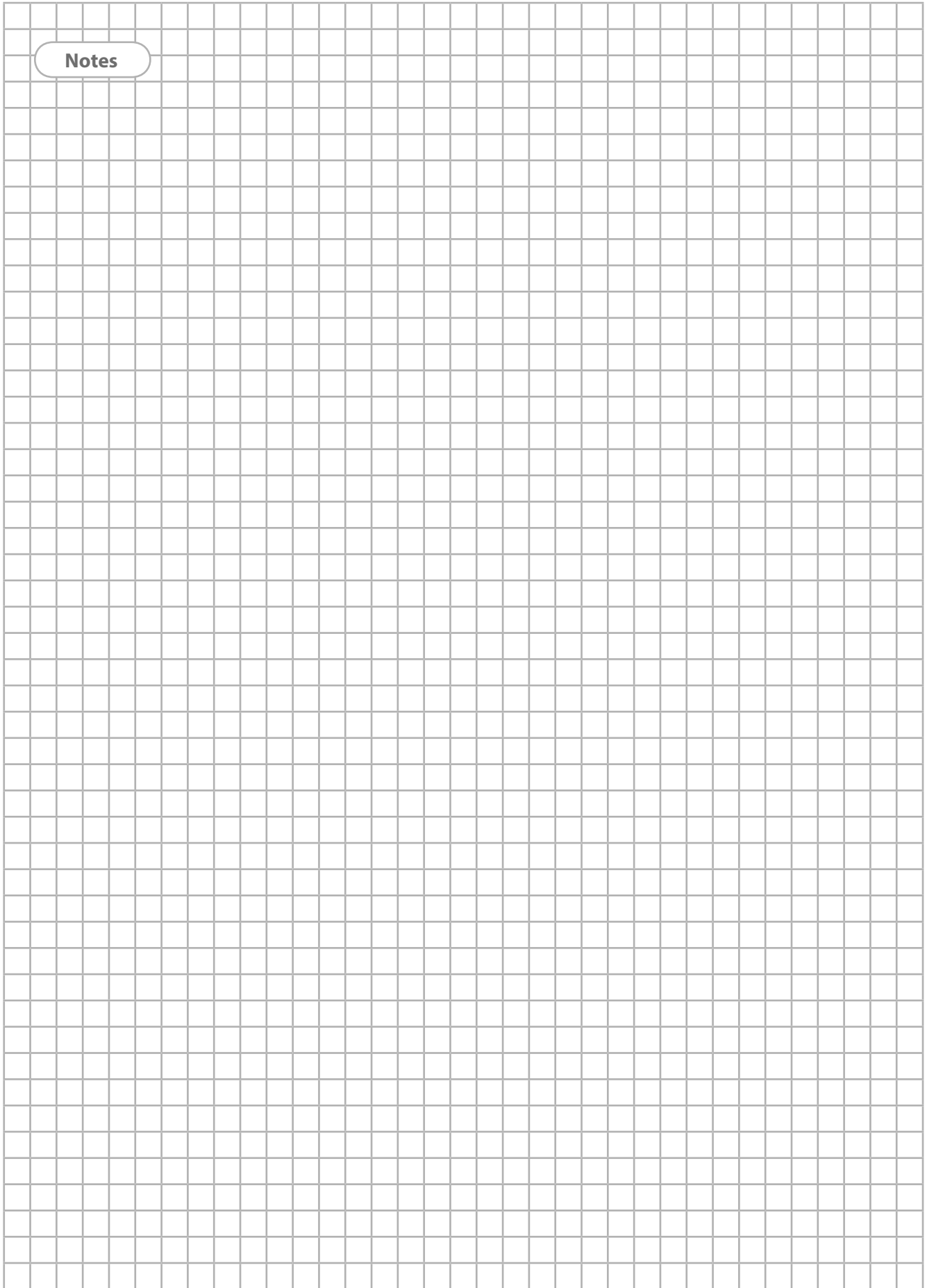



Treadmill TX70