

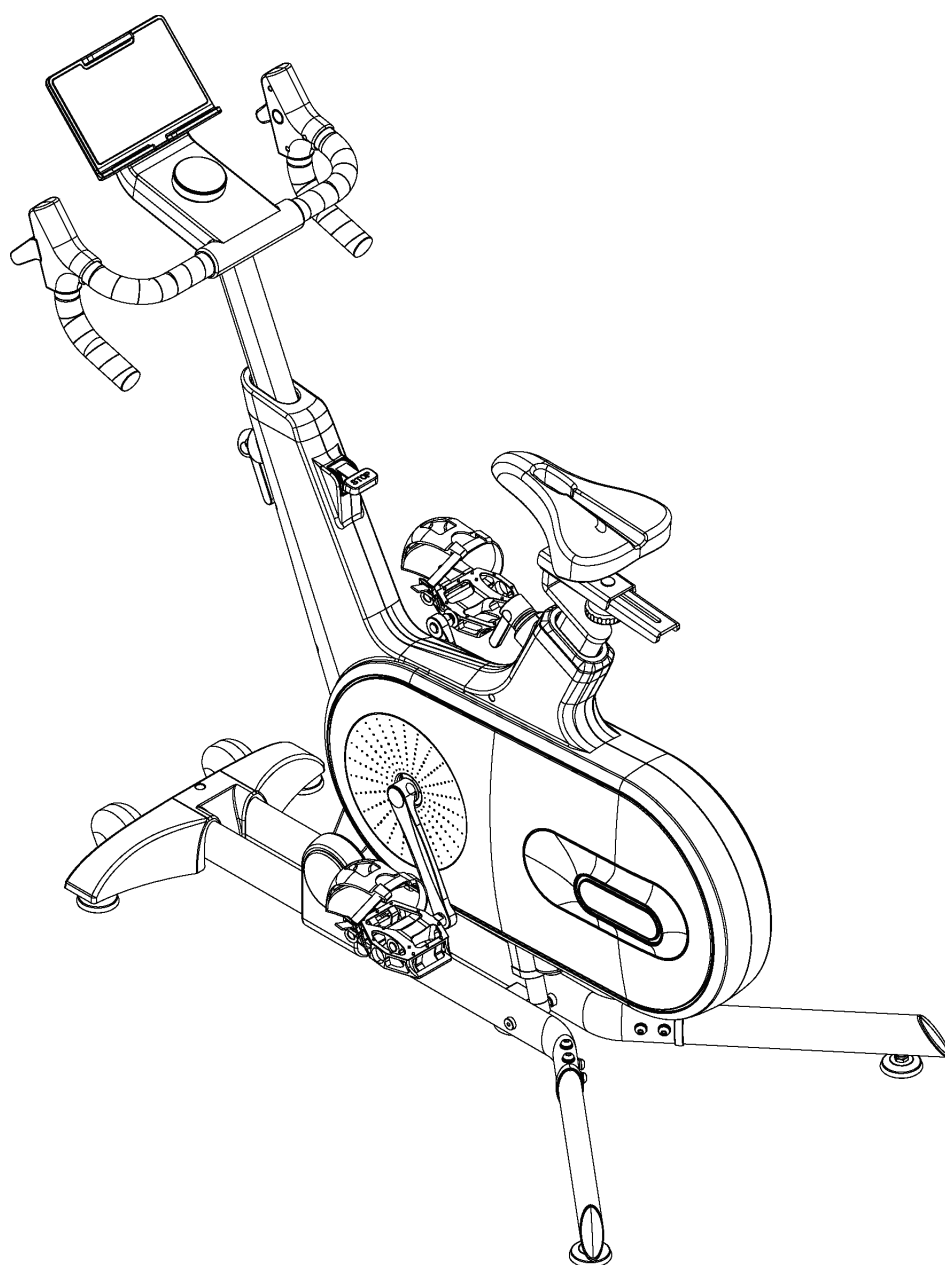

## Assembly and Operating Instructions



max. 130 kg



~ 60 Min.



39 kg  
L 150 | W 80 | H 116

FSUKCSTIB50.01.01

SKU: CST-IB50

**Cardiostrong IB50**



# Content

<b>1</b>	<b>GENERAL INFORMATION</b>	<b>8</b>
1.1	Technical Data	8
1.2	Personal Safety	9
1.3	Electrical Safety	10
1.4	Set-Up Place	11
<b>2</b>	<b>ASSEMBLY</b>	<b>12</b>
2.1	General Instructions	12
2.2	Scope of Delivery	13
2.3	Assembly	15
<b>3</b>	<b>OPERATING INSTRUCTIONS</b>	<b>24</b>
3.1	Console	24
3.2	Button functions	25
3.3	Programmes	26
3.4	Standby and automatic STOP mode	26
3.5	Switching off	26
3.6	Calibration	26
3.7	Wireless Connection and Fitness Apps	27
<b>4</b>	<b>STORAGE AND TRANSPORT</b>	<b>28</b>
4.1	General Instructions	28
4.2	Transportation Wheels	28
<b>5</b>	<b>TROUBLESHOOTING, CARE AND MAINTENANCE</b>	<b>29</b>
5.1	General Instructions	29
5.2	Faults and Fault Diagnosis	29
5.3	Error Codes and Troubleshooting	30
5.4	Maintenance and Inspection Calendar	31
<b>6</b>	<b>DISPOSAL</b>	<b>31</b>
<b>7</b>	<b>RECOMMENDED ACCESSORIES</b>	<b>32</b>
<b>8</b>	<b>ORDERING SPARE PARTS</b>	<b>33</b>
8.1	Serial Number and Model Name	33
8.2	Parts List	34
8.3	Exploded Drawing	38



**Dear customer,**

thank you for choosing fitness equipment from cardiostrong®. cardiostrong offers high-quality home fitness equipment that is optimally adapted to the conditions at home. Train at home no matter what the weather or time of the day. cardiostrong fitness equipment offers training programmes and a variety of equipment for all training levels and all training goals. Further information can be found at [www.fitshop.com](http://www.fitshop.com) or [www.cardiostrong.de](http://www.cardiostrong.de). We hope you enjoy your training!

Further information can be found at [www.fitshop.co.uk](http://www.fitshop.co.uk)

**Intended Use**

The equipment may only be used for its intended purpose.

The equipment is only suitable for home use. The equipment is not suitable for semi-professional (e.g. hospitals, associations, hotels, schools, etc.) and commercial or professional use (e.g. fitness studios).

**Legal Notice**

Fitshop GmbH  
Europe's No. 1 for home fitness

International Headquarters  
Flensburger Straße 55  
24837 Schleswig  
Germany

Management:  
Christian Grau  
Sebastian Campmann  
Dr. Bernhard Schenkel  
No. HRB 1000 SL  
Local Court Flensburg  
European VAT Number: DE813211547

**Disclaimer**

© cardiostrong is a registered brand of the company Fitshop GmbH. All rights reserved. Any use of this trademark without the explicit written permission of Fitshop is prohibited.

Product and manual are subject to change. Technical data can be changed without advance notice.

# FITSHOP

Europe's No.1 for Home Fitness

## ABOUT THIS MANUAL

Please carefully read the entire manual before installation and first use. The manual will help you to quickly set up the system and explains how to safely use it. Make sure that all persons exercising with the equipment (especially children and persons with physical, sensory, mental or motor disabilities) are informed about this manual and its contents in advance. In case of doubt, responsible persons must supervise the use of the equipment.

Due to ongoing changes and software optimisations, the manual may have to be updated. If you notice any discrepancies during assembly or use, please refer to the manual uploaded to the webshop. The latest manual is always available there.



This equipment has been manufactured according to the latest safety knowledge. As far as possible, potential safety hazards which could cause injury have been eliminated. Make sure to carefully follow the instructions and that all parts are securely in place. If required, read through the instructions again to correct any mistakes.

Training devices must be classified according to accuracy and use. Accuracy classes are only applicable to devices that display training data.

### Accuracy classes

Class A: high accuracy.

Class B: medium accuracy.

Class C: low accuracy.

The use classes explain the intended use of the training device.

### Use classes

**Class S** (studio): professional and/or commercial use.

These training devices are intended for the use in training rooms of facilities such as sports clubs, school facilities, hotels, clubs and studios whose access and supervision is specifically regulated by the owner (person with legal responsibility).

**Class H** (home use): use at home.

These stationary training devices are intended for the use in private homes where access to the training device is regulated by the owner (person with legal responsibility).

Please pay close attention to the safety and maintenance instructions given here. The contract partner cannot be held liable for damage to health, accidents or damage to the equipment when it is not used in accordance with these instructions.

The following safety instructions may appear in this manual:

► **ATTENTION**

This notice indicates potentially hazardous situations which, if not avoided, may result in property damage.

⚠ **CAUTION**

This notice indicates potentially hazardous situations which, if not avoided, may result in slight or minor injuries!

⚠ **WARNING**

This notice indicates potentially hazardous situations which, if not avoided, may result in death or serious injuries!

⚠ **DANGER**

This notice indicates potentially hazardous situations which, if not avoided, will result in death or serious injuries!

ⓘ **NOTICE**

This notice indicates further useful information.

Retain these instructions in a safe place for future reference, maintenance or when ordering replacement parts.

## 1.1 Technical Data

LED Display:

- + Time
- + Speed
- + Distance
- + Calories
- + Watt
- + Incline

Brake system: Magnetic  
Resistance levels: 32  
Balance mass: 8 kg

Programmes: 3

### **Watt:**

Speed independent programmes:

Min. and max Watt with 60 RPM: 47 W - 320 W  
Min. and max. Watt with 100 RPM: 104 W - 746 W

Speed-dependent programmes:

Min. and max. Watt: 47 W - 320 W

### **Weight and Dimensions:**

Article weight (gross, including packaging): 45 kg

Article weight (net, without packaging): 39 kg

Packaging dimensions (L x W x H): 109 cm x 24 cm x 82 cm

Set-up dimensions (L x W x H): 150 cm x 80 cm x 116 cm

Maximum user weight: 130 kg

Use class: H



## 1.2 Personal Safety

### **DANGER**

- + Before you start using the equipment, you should consult your physician that this type of exercise is suitable for you from a health perspective. Particularly affected are persons who: have a hereditary disposition to high blood pressure or heart disease, are over the age of 45, smoke, have high cholesterol values, are overweight and/or have not exercised regularly in the past year. If you are under medical treatment that affects your heart rate, medical advice is absolutely essential.
- + Note that excessive training can seriously endanger your health. Please also note that heart rate monitoring systems can be inaccurate. If you notice any signs of weakness, nausea, dizziness, pain, shortness of breath, or other abnormal symptoms, stop exercising immediately and seek advice from your doctor if necessary.
- + The owner must communicate all warnings and instructions to the user.

### **WARNING**

- + This equipment may not be used by children under the age of 14.
- + Children should not be allowed unsupervised access to the equipment.
- + Persons with disabilities must have a medical license and must be under strict observation when using the equipment.
- + The equipment is strictly for use by one person at a time.
- + If your equipment provides a safety key, the clip of the safety key must be attached to your clothing before starting your training. In the event of a fall, the EMERGENCY STOP of the equipment can be initiated.
- + There is a risk of injury from spinning pedals and/or an exposed flywheel in the absence of a freewheel. Never get on or off the equipment when the pedals or the flywheel are still moving. Always make sure that the pedals and the flywheel have come to a complete stop.
- + Support yourself with at least one hand on the handlebar when getting on and off the equipment. Only dismount from the equipment when the pedals have come to a complete stop.
- + Keep your hands, feet and other body parts, hair, clothing, jewellery and other objects well clear of moving parts.
- + During use, wear suitable sports clothing rather than loose or baggy clothing. When wearing sports shoes, make sure they have suitable soles, preferably made of rubber or other non-slip materials. Shoes with heels, leather soles, studs or spikes are unsuitable. Never exercise barefoot.

### **CAUTION**

- + If your equipment needs to be connected to the power supply with a mains cable, make sure that the cable is not a potential tripping hazard.
- + Make sure that nobody is within the range of motion of the equipment during training so as not to endanger you or other persons.
- + Always tighten the pedal strap before you start training to prevent your feet from slipping.

**⚠ CAUTION**

- + Be aware that if adjustment devices are left protruding, they may impede the user's movement.

**▶ ATTENTION**

- + Do not insert any objects of any kind into the openings of the device.
- + To protect the equipment from use by unauthorised third parties, always remove the power cable (if existing) when not in use and store it in a safe place that is inaccessible to unauthorised persons (e.g. children).
- + Class B and C crank training equipment is not suitable for high accuracy purposes.

## 1.3 Electrical Safety

**⚠ DANGER**

- + In order to reduce the risk of an electric shock, always unplug the equipment from the mains socket immediately after your workout, before assembly or dismantling, and before maintenance or cleaning. Do not pull on the cable.

**⚠ WARNING**

- + Do not leave the equipment unattended while the mains cable is plugged into the mains socket. During your absence, the mains cable must be removed from the mains socket to prevent improper use by third parties or children.
- + If the mains cable or plug is damaged or defective, contact your contract partner. Until repair, the equipment must not be used.

**▶ ATTENTION**

- + The equipment requires a mains connection of 220-230 V with 50 Hz mains voltage.
- + The equipment may only be connected directly to an earthed socket using the supplied mains cable. Extension cables must conform to VDE guidelines. Always completely unwind the mains cable.
- + The socket must be protected by a fuse with a minimum fuse rating of "16 A, slow blow".
- + Do not make any changes to the mains cable or the mains plug.
- + Keep the mains cable away from water, heat, oil and sharp edges. Do not route the mains cable underneath the equipment or under a carpet or rug, and do not place any objects on top of it.
- + If your purchased item is equipped with a TFT console, software updates must be carried out regularly. Follow the instructions on the console to perform the update(s).
- + The software systems on gym equipment with TFT consoles are set up only for the pre-installed apps. Do not install any additional apps.

**ⓘ NOTICE**

- + The pre-installed apps on TFT consoles are produced and provided by external manufacturers. Fitshop does not take any responsibility for the availability, functionality or contents of these apps.

## 1.4 Set-Up Place

### **WARNING**

- + Do not place the equipment in main corridors or escape routes.

### **CAUTION**

- + Choose a location in which to place the equipment such that there is enough free space/clearance to the front, the rear and to the sides of the equipment.
- + The training room should be well ventilated during training and not be exposed to any draughts.
- + Choose the place in which to set up the equipment such that there is enough free space/clearance to the front, the rear and to the sides of the equipment.
- + The free area in the direction from which the exercise equipment is accessed must be at least 0.6 m larger than the exercise area.
- + The set-up and mounting surface of the equipment should be flat, loadable and solid.

### **ATTENTION**

- + The device may only be used in one building, in sufficiently tempered and dry rooms (ambient temperatures between 10°C and 35°C). The equipment should not be used outdoors or in rooms with high humidity (over 70%) like swimming pools.
- + A floor protective mat/equipment underlay can help to protect high-quality floor coverings (parquet, laminate, cork, carpets) from dents and sweat and can help to level out slight unevenness.
- + For Class S equipment, the exercise equipment may only be used in areas where access, supervision and control are specifically regulated by the owner.

### 2.1 General Instructions

**⚠ DANGER**

- + Do not leave any tools, packaging materials such as foils or small parts lying around, as otherwise there is a danger of suffocation for children. Keep children away from the equipment during assembly.

**⚠ WARNING**

- + Pay attention to the instructions attached to the equipment in order to reduce the risk of injuries.

**⚠ CAUTION**

- + Ensure to have sufficient room for movement in each direction during assembly.
- + The assembly of the equipment must be carried out by at least two adults. If in doubt, seek the help of a third technically skilled person.

**▶ ATTENTION**

- + To prevent damage to the equipment and the floor, assemble the equipment on a mat or packaging board.

**ⓘ NOTICE**







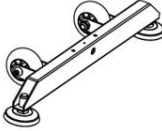

- + In order to make the assembly as simple as possible, some screws and nuts to be used can already be pre-assembled.
- + Ideally, assemble the equipment at its later set-up place.

## 2.2 Scope of Delivery

The scope of delivery consist of the following parts. At the beginning, check whether all parts and tools belonging to the device are included in the scope of delivery and whether damage has occurred. In the event of complaints, the contractual partner must be contacted directly.

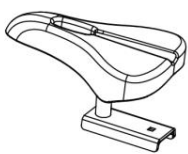
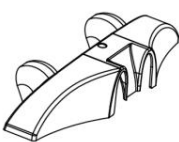
**⚠ CAUTION**

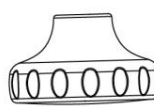
If parts of the scope of delivery are missing or damaged, the assembly must not be carried out.

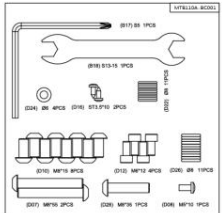
 A	 B	 C	 D	 E
 F	 G	 C28	 C45	 C46
 C21	 D02	 E16		

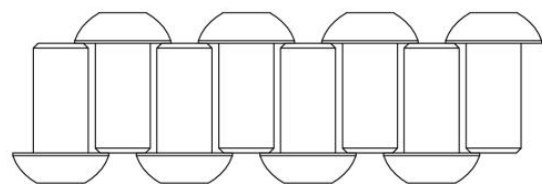
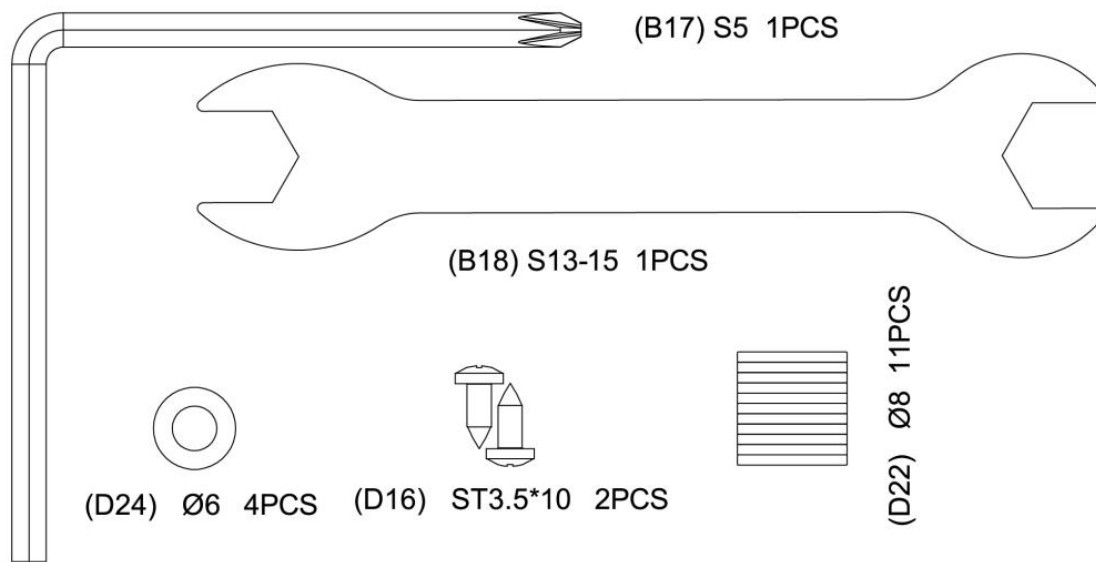

(D10) M8\*15 8PCS

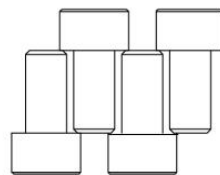

(D12) M6\*12 4PCS



(D26) Ø8 11PCS

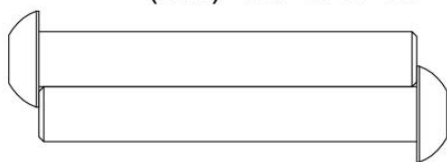

(D07) M8\*55 2PCS

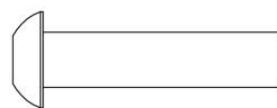

(D28) M8\*35 1PCS



(D08) M5\*10 1PCS

## 2.3 Assembly

Before assembly, take a close look at the individual assembly steps shown and carry out the assembly in the order given.

### ① NOTICE

- + First loosely screw all parts together and check that they fit properly. Tighten the screws using the tool only when you are instructed to do so.
- + If you have difficulty recognising the graphics, we recommend that you open and/or download the PDF instructions stored in the webshop on your end device (e.g. smartphone, tablet or PC). There you have the option of zooming in closer. Please note that the Adobe Acrobat Reader programme must be installed on your end device in order to open the file.

### Step 1: Mounting the feet

1. Attach the front foot pad fixing tube group (B) to the main frame assembly (A) with two 3-in-1 screws (D07), two spring washers (D26), and two washers (D22), and one 3-in-1 screw (D28), one spring washer (D26), and one washer (D22).

Use the wrench (B17) for this.

2. Attach the left stand (C) to the main frame (A) with four 3-in-1 screws (D10), four spring washers (D26), and four washers (D22).

Use the wrench (B17) to do this.

3. Repeat step 2 for the right-hand stand (D).
4. Tighten all the screws firmly.

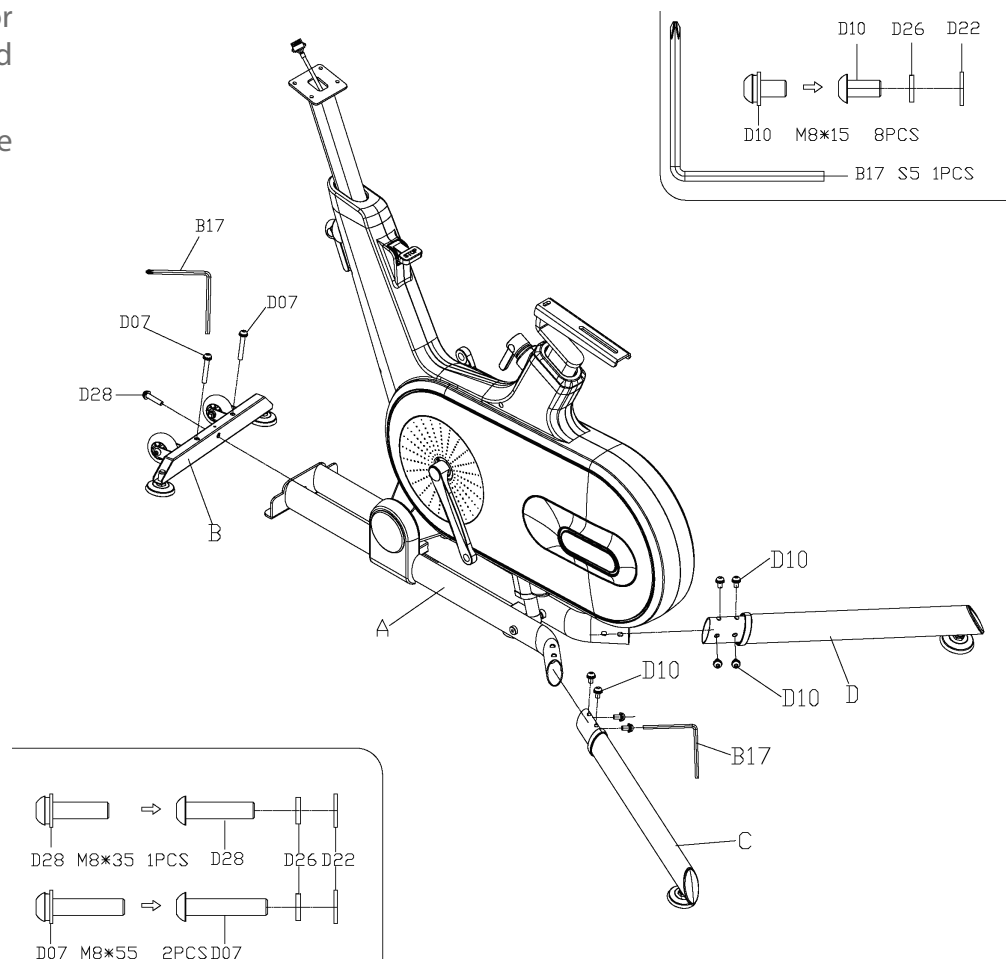

## Step 2: Assembly of the Tablet Holder

1. Plug the buckle (H) on the tablet holder group (E) into the square hole (K9) of the electronic watch group (F).
2. Fix the tablet holder group (E) with a cross pan head self-tapping screw (D16).

*Use the cross wrench (B17) for this.*

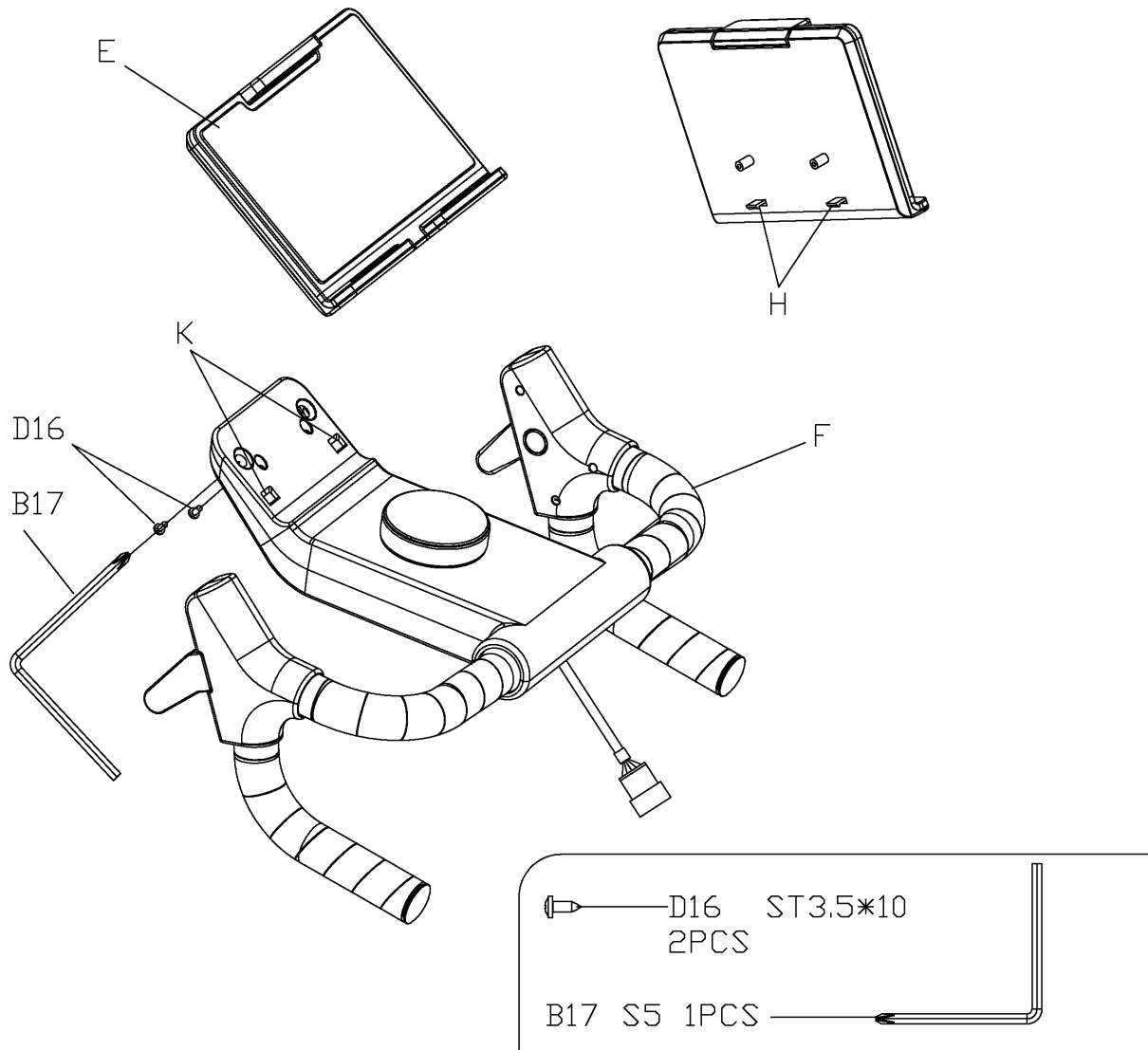



### Step 3: Assembly of the handlebar

1. Connect the upper segment wire (E09) with the lower segment wire (E10).
2. Mount the electronic metre group (F) to the instrument tube group (A02) with four 2-in-1 screws (D12).

Use the hex wrench (B17) for this.

► **CAUTION**

Make sure that the cable is not trapped between the two connecting parts.

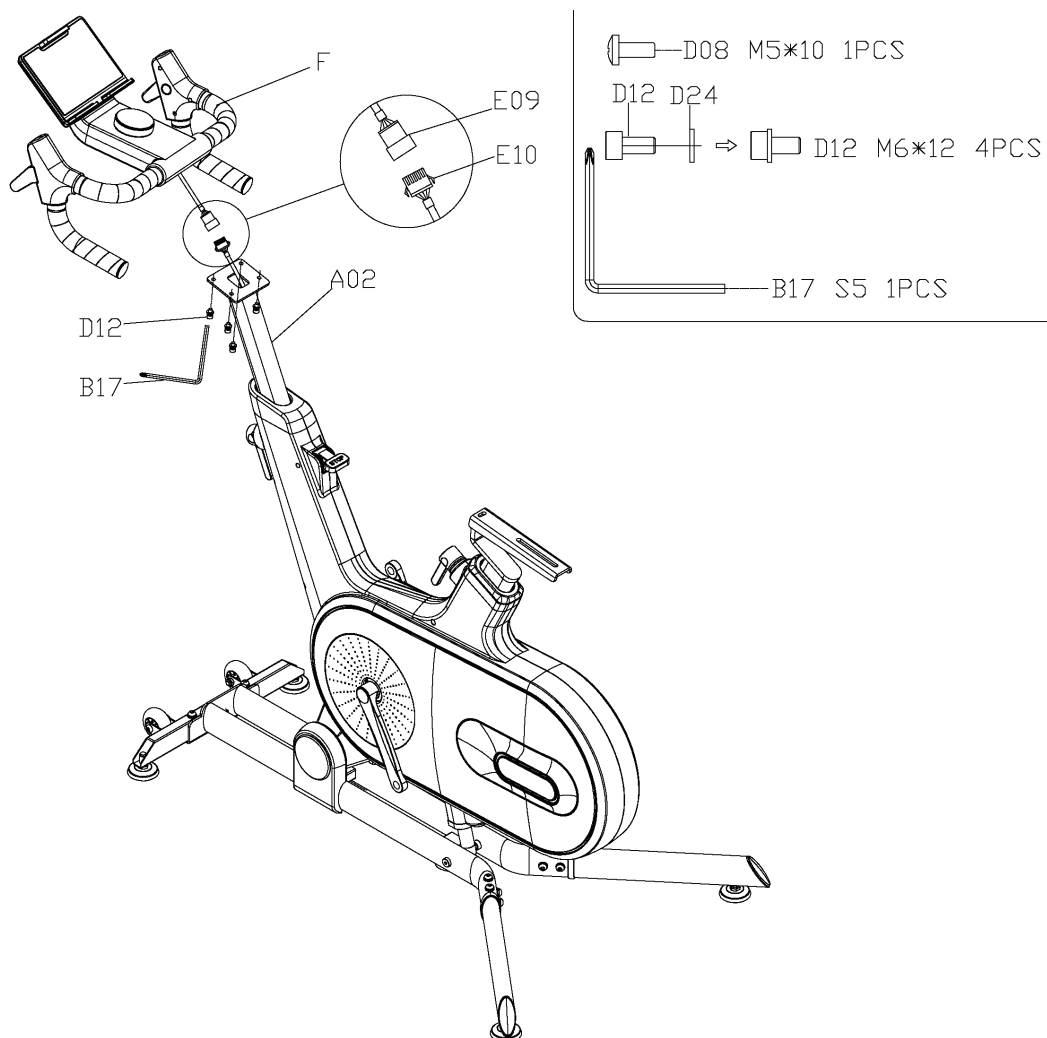

#### Step 4: Assembly of the Pedals

1. Fix the left pedal (C45) to the left crank (B01).

Use the cross wrench (B18) for this.

2. Fix the right pedal (C46) to the right crank (B02).

Use the cross wrench (B18) for this.

**NOTE**

When fitting the pedals, ensure that the direction of rotation is correct (see illustration).

3. Mount the front foot cover (C28) to the front foot pad fixing tube group (C28) with one screw (D01).

Use the cross wrench (B17) for this.

**CAUTION**

Make sure to screw in the pedals completely.

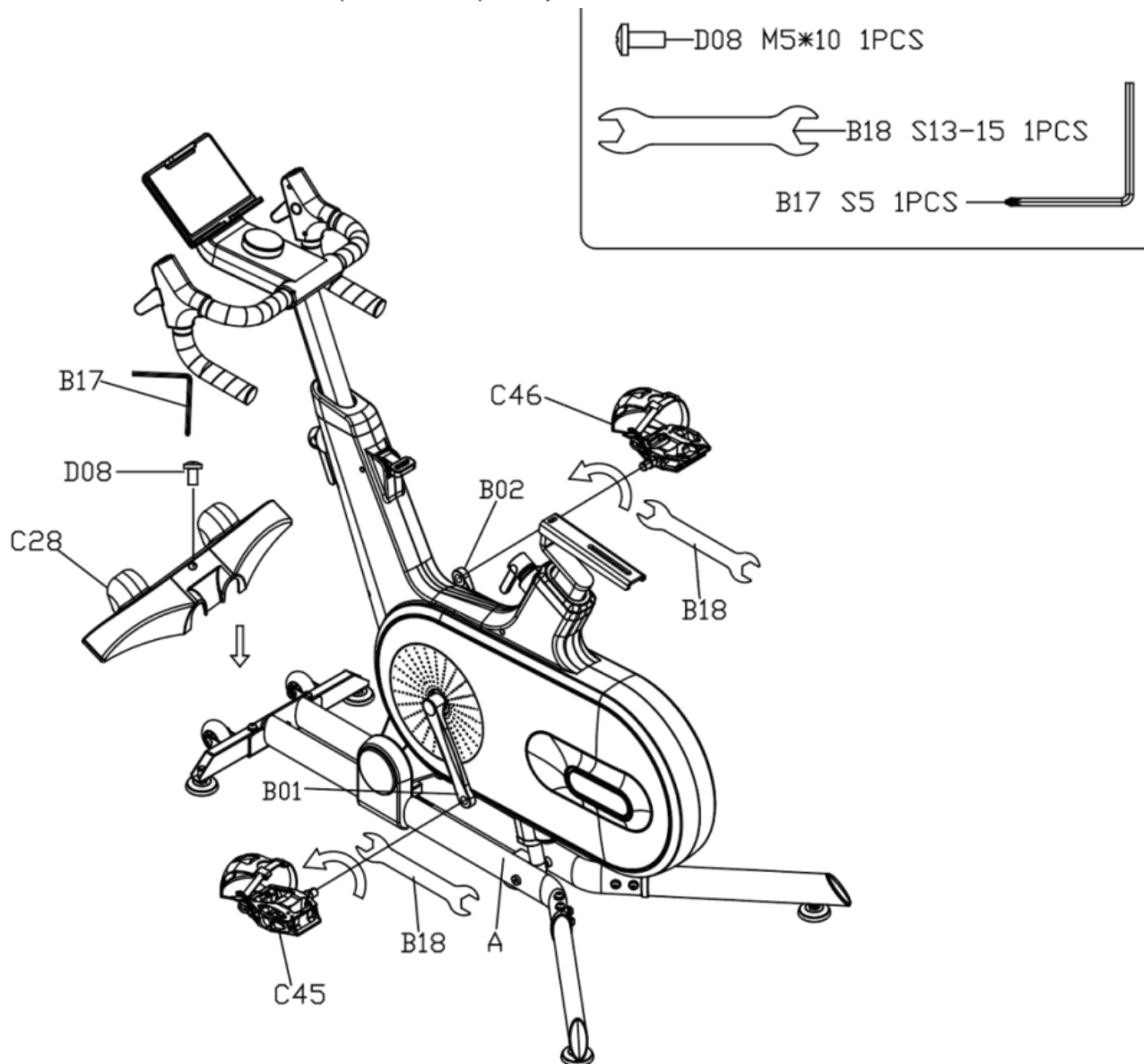

### Step 5: Assembly of the Saddle

Mount the seat pack (G) to the seat pack tube (A03) with the twist (C21) and one square neck bolt (D02).

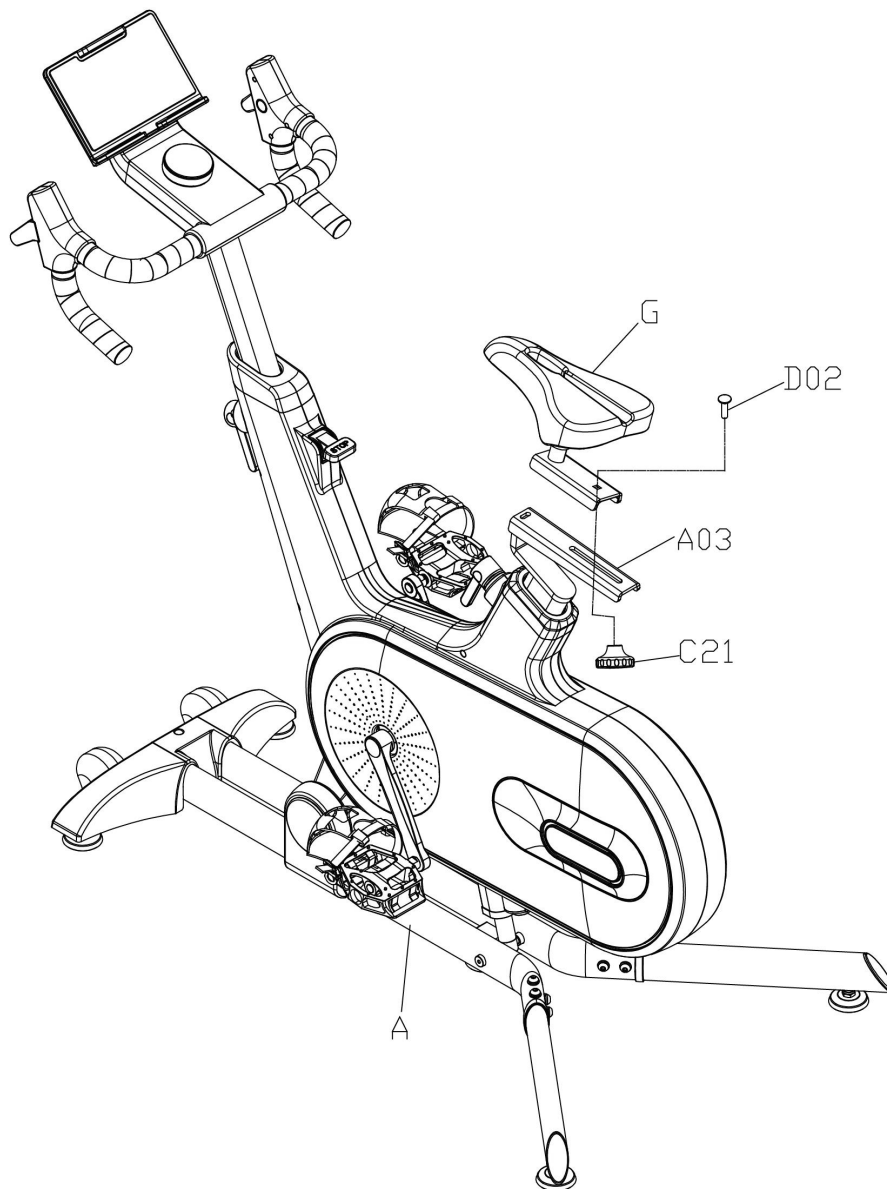

## Step 6: Connecting the Power Supply Unit

1. Plug the power supply unit (E16) into the power supply unit connection (E14).
2. Tighten all the screws.

→ *The machine is assembled.*

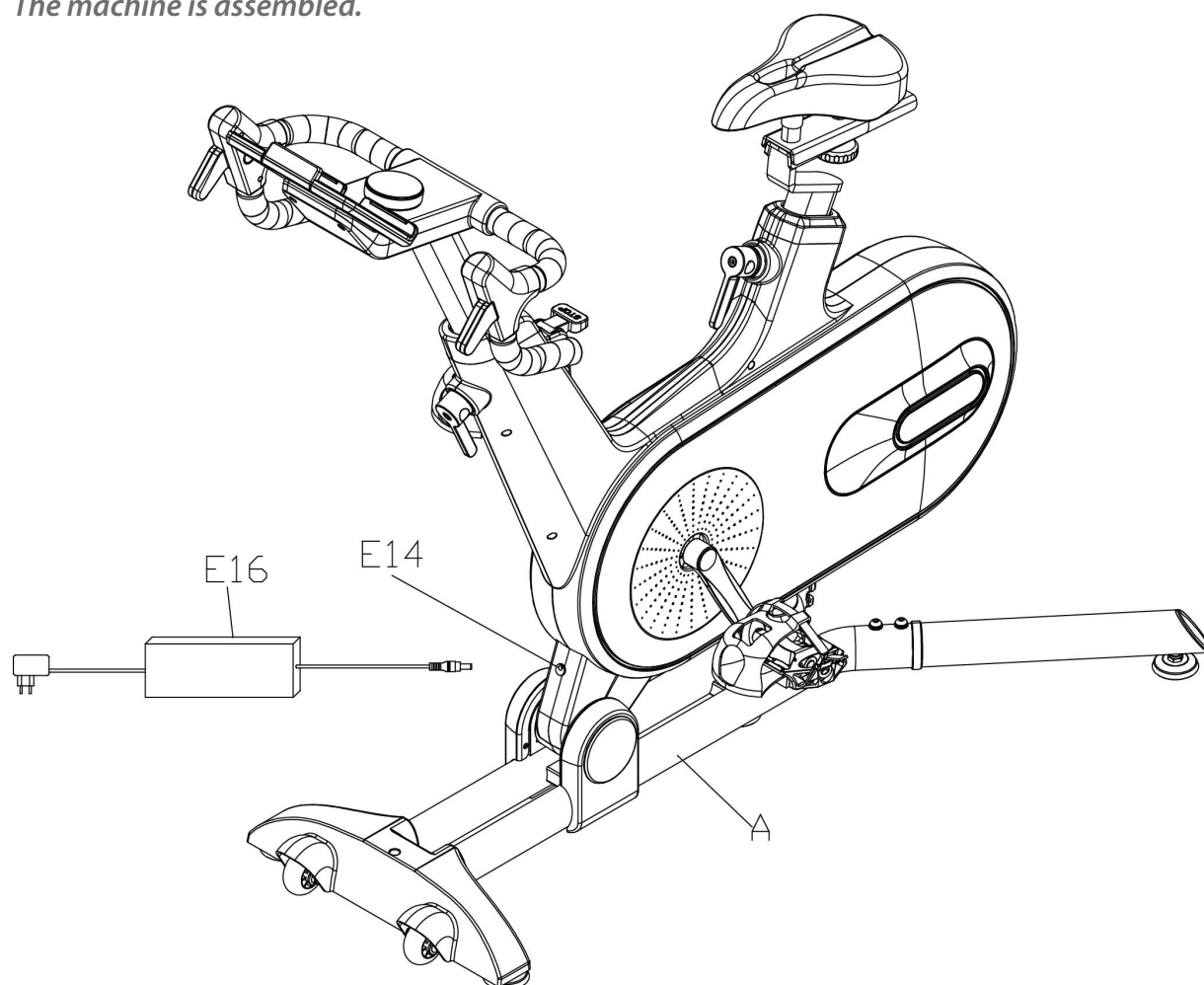

### Step 7: Alignment of the Feet

If the floor is uneven, you can stabilise the equipment by turning the two setting screws under the main frame.

1. Lift the equipment on the desired side and rotate the setting screws under the main frame.
2. Rotate the screws clockwise in order to remove them and to raise the equipment.
3. Rotate them counterclockwise in order to lower the equipment.

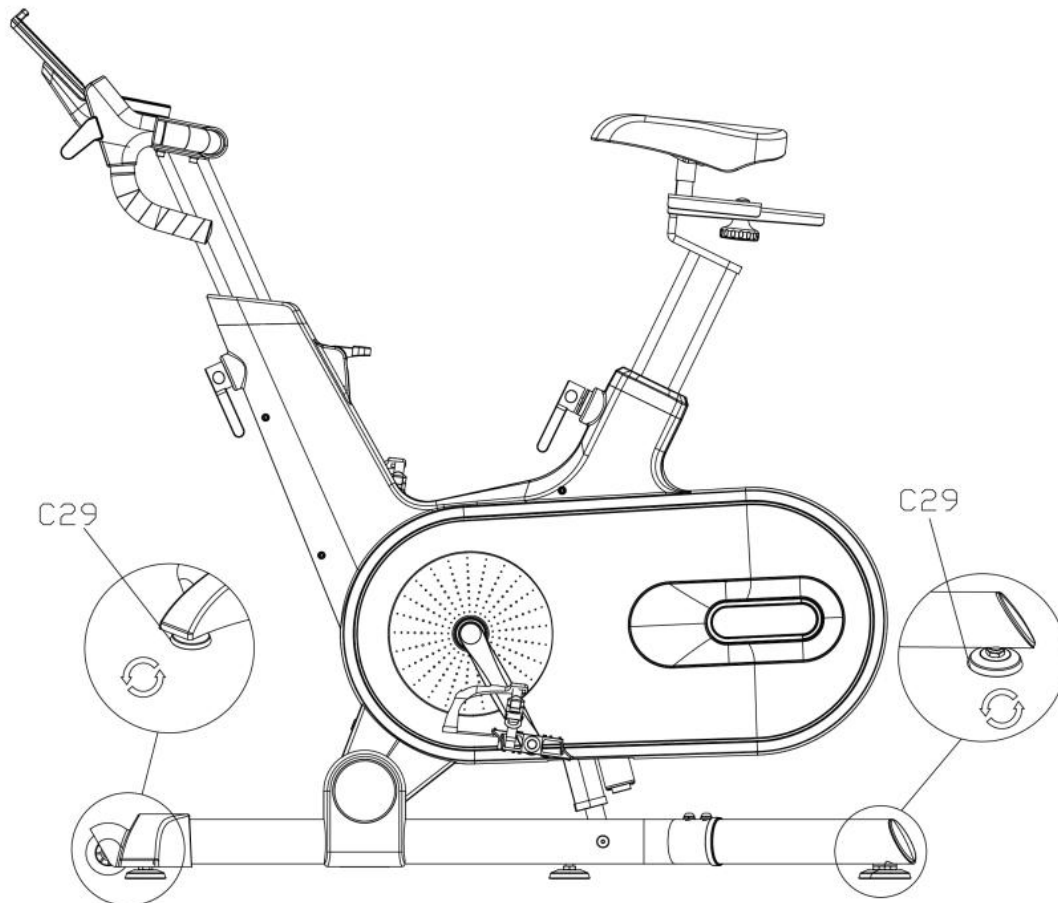

## Step 8: Adjusting the Seat Position

### ⚠ CAUTION

When adjusting, make sure not to exceed the minimum insertion depth.

1. To adjust the seat height, loosen the L-shaped elastic pin assembly (B12) by turning it anti-clockwise.
2. Adjust the seat height.
3. Tighten the L-shaped elastic pin assembly (B12) by turning it clockwise.

## Step 9: Adjusting the Handlebar Position

### ⚠ CAUTION

When adjusting, make sure not to exceed the minimum insertion depth.

1. To adjust the handlebar height, loosen the L-shaped elastic pin assembly (B12) by turning it anti-clockwise.
2. Adjust the handlebar height.
3. Tighten the L-shaped elastic pin assembly (B12) by turning it clockwise.

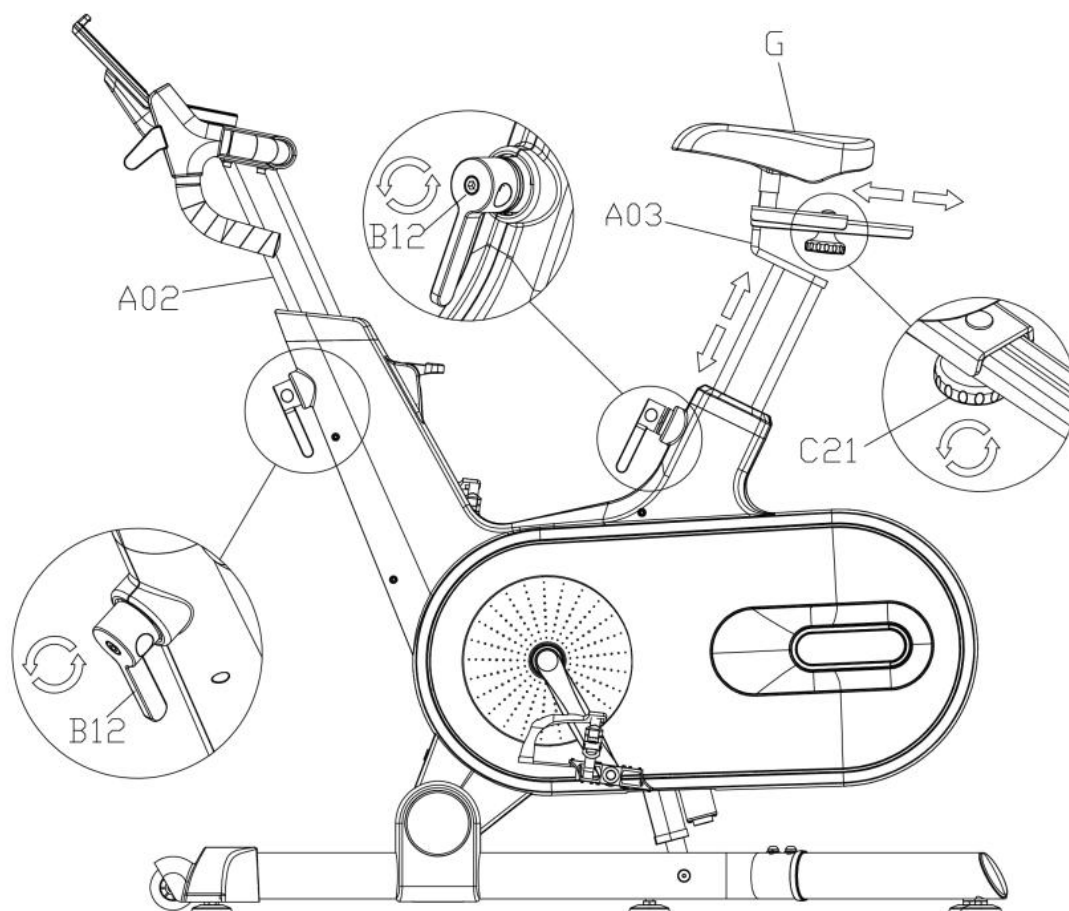

## Step 10: Connecting the Equipment to the Mains Supply

### ▶ **ATTENTION**

The equipment must not be connected to a multiple socket, otherwise it cannot be guaranteed that the equipment will be supplied with sufficient power. Technical errors can result.

Plug the power plug into a wall outlet that complies with the instructions in the chapter on electrical safety.

## Correctly Getting On and Off

1. To get on, grip the handles with both hands and first step onto the left pedal with your left foot or onto the right pedal with your right foot and then place your foot onto the other pedal.
2. To get off, grip the handles with both hands and place one foot next to the equipment and then the other foot.

## Step 11: Adjusting the Pedal Straps

### ⓘ **NOTICE**

The strap should rest loosely over the ball of the foot and not sit firmly under any circumstances.





## 3 OPERATING INSTRUCTIONS

### ① NOTICE

- + Familiarise yourself with all the functions and setting options of the device before starting training. Have the proper use of this product explained to you by a specialist.
- + Always start your training with low intensity and increase evenly and gently. End your training with a cool-down phase. If you are unsure, please consult your physician.

### 3.1 Console



Symbol	Function
	Time: Display range from 0:00 to 99:59
	Watt display: Displays the current wattage from 0 to 999
	Distance display: Display range from 0.00 to 99.99
	Speed display: Display range from 0 to 200 RPM
	Incline display: Display range -8 to 8



B	Wireless technology: If wireless access is available, the symbol lights up.
	Resistance display: Display range: 1 to 32 segments

### 3.2 Button functions

Button	Function
Start/Stop	<ul style="list-style-type: none"> <li>+ Press the button in stop mode to start training.</li> <li>+ When the device is in operation, the training stops when pushed.</li> <li>+ When stopped, press for 1 second to resume exercise and press and hold for 3 seconds to delete data.</li> </ul>
Rotary knob Clockwise	<ul style="list-style-type: none"> <li>+ in the operating state of the appliance, increase the value of the resistance gear.</li> <li>+ In standby mode, select the built-in programme P1-P2-P3 by pushing.</li> </ul>
Rotary knob anti-clockwise clockwise	<ul style="list-style-type: none"> <li>+ When the appliance is in operating mode, the value of the resistance gear is reduced.</li> <li>+ In standby mode, select the built-in programme P1-P2-P3.</li> </ul>
Gear plus/ minus button	During operation, the current gear value can be can be set.
Incline plus/ minus button	The inclination can be adjusted during operation.

### 3.3 Programmes

The following table provides an overview of the available programmes. The individual training segments change every ten seconds.

Time Incline		Running time:10 seconds															
		1	2	3	4	5	6	7	8	9	10	11	12	13	14	15	16
P1	gears	10	12	16	8	2	10	16	10	2	18	10	4	12	8	12	6
	incline	0	6	8	-2	-8	0	8	0	-8	8	0	-6	6	-2	6	0
P2	gears	10	14	16	10	5	10	20	6	16	12	5	20	12	8	14	6
	incline	0	6	8	2	-8	0	6	-6	6	0	-8	8	2	-3	4	0
P3	gears	10	18	6	18	3	16	3	10	22	6	18	6	20	6	16	6
	incline	0	8	-8	6	-8	4	-8	0	6	-6	4	-6	6	-2	4	0

### 3.4 Standby and automatic STOP mode

If the device does not detect a movement signal for one minute, the device switches to STOP mode. If the appliance is not moved for 10 minutes in STOP mode, the appliance automatically switches to standby. The appliance can be activated in standby mode by moving or pushing the rotary knob.

### 3.5 Switching off

The machine can be turned off at any time by pressing the power switch.

### 3.6 Calibration

It is recommended to calibrate the device after replacing parts or if an incorrect incline indication is suspected.

1. The device is in standby mode.
2. Press both incline buttons for three seconds.

*The device automatically calibrates the inclination.*

**NOTE**

Contact our technical customer service if error code 04 is displayed.

### 3.7 Wireless Connection and Fitness Apps

This console is equipped with a wireless interface. Please take note that your mobile device needs to be compatible with the wireless interface of the treadmill.

To use training apps you will have to activate the wireless connection function on your mobile device (tablet or smart phone) and start the fitness app. Select your fitness equipment. Please follow the instructions given in the app. You will find the name of your fitness equipment on a small sticker on the back of the console.

You will find the fitness apps in the app stores of Google or Apple. There you will find the apps "Kinomap" or "Zwift". Please note that these apps are produced by an external manufacturer. Fitshop does not take any responsibility regarding the availability, functionality or contents of these programmes.

#### IMPORTANT NOTE

The pre-installed apps are produced and provided by external manufacturers. Changes and availability within these apps might occur. Fitshop does not take any responsibility and can not be held liable for the availability, functionality or contents of these apps. To make sure the pre-installed apps are working correctly, they must be updated regularly. If needed, the respective app will notify you to do so. To update the app, you need a google account. A google email is sufficient. Just follow the instructions on the screen to perform the update.

Please note: The system is set up only for the pre-installed apps. Do not install any additional apps as their proper functionality can not be guaranteed. The installation of other apps might cause technical issues.

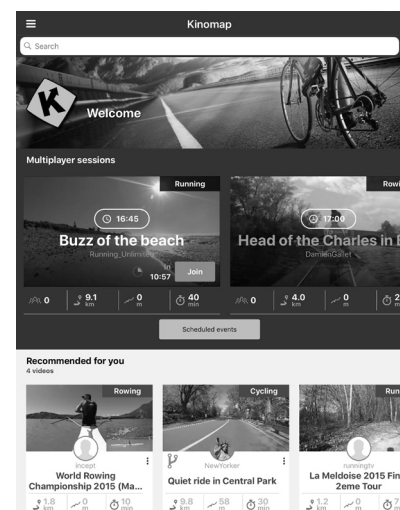
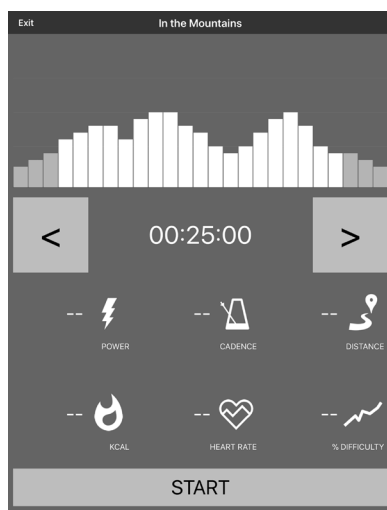

Example: Kinomap

## 4.1 General Instructions



### WARNING

- + The storage location should be chosen so that improper use by third parties or children can be prevented.
- + If your equipment does not have transportation wheels, the equipment must be disassembled before transportation.



### ATTENTION

- + Make sure that the equipment is protected from moisture, dust and dirt in the selected storage location. The storage location should be dry and well ventilated and have a constant ambient temperature between 10°C and 35°C.

## 4.2 Transportation Wheels



### ATTENTION

If you want to transport your equipment over particularly sensitive and soft floor coverings, such as parquet, planks or laminate, lay out the transport route with cardboard or similar to avoid possible floor damage.

1. Stand behind the equipment and lift it until the weight is transferred to the transportation wheels. After that, you easily can move the equipment to a new position. For long transport distances the equipment should be disassembled and safely packed.
2. Select the new location by following the instructions in the section 1.4 of this manual.

### 5.1 General Instructions

**⚠ WARNING**

- + Do not make any improper changes to the equipment.

**⚠ CAUTION**

- + Damaged or worn components may affect your safety and the life of the equipment. Therefore, immediately replace damaged or worn components. In such a case, contact the contract partner. The equipment must not be used until it has been repaired. If necessary, use only original spare parts.

**▶ ATTENTION**

- + In addition to the instructions and recommendations for maintenance and care given here, additional service and/or repair work may be necessary; this must only be carried out by authorised service technicians.

### 5.2 Faults and Fault Diagnosis

The equipment undergoes regular quality controls during production. Nevertheless, faults or malfunctions may occur. Frequently, individual parts are responsible for these disturbances, an exchange is usually sufficient. Please refer to the following overview for the most common errors and how to correct them. If the equipment still does not function properly, contact your contract partner.

<b>Fault</b>	<b>Cause</b>	<b>Solution</b>
Cracking in the pedal area	Pedals loose	Tighten the pedals
Equipment wobbles	Equipment is not level	Align the feet
Handlebar/saddle wobbles	Loose screws	Tighten screws firmly
Display is blank/is not working	Batteries empty or loose cable connection	Replace batteries or check cable connections

No pulse display	<ul style="list-style-type: none"> <li>+ Sources of interference in the room</li> <li>+ unsuitable chest strap</li> <li>+ Wrong position of chest strap</li> <li>+ Chest strap defective or battery empty</li> <li>+ Pulse display defective</li> </ul>	<ul style="list-style-type: none"> <li>+ Eliminate sources of interference (e.g. mobile phone, WLAN, lawn mower and vacuum cleaner robot, etc. ...)</li> <li>+ Use a suitable chest strap (see RECOMMENDED ACCESSORIES).</li> <li>+ Reposition chest strap and/or moisten electrodes</li> <li>+ Changing batteries</li> <li>+ Check if pulse display by hand pulse possible</li> </ul>
------------------	---	--

### 5.3 Error Codes and Troubleshooting

The electronics of the equipment continuously carries out tests. In case of deviations, an error code appears on the display and normal operation is stopped for your safety.

Error code 04: Check the motor and the motor signal cable.

**Please contact the contract partner for technical support.**

## 5.4 Maintenance and Inspection Calendar

To avoid damage from body sweat, the equipment must be cleaned with a damp towel (no solvents!) after each training session.

The following routine tasks must be performed at the specified intervals:

Part	Weekly	Monthly
Display console	C	I
Plastic covers	C	I
Screws and cable connections		I
Check pedals for tightness		I
Legend: C = clean; I = inspect		

## 6 DISPOSAL

At the end of its operational life, this equipment cannot be disposed of in normal household waste. Instead, it must be disposed of via an electricals recycling centre. Further information can be obtained from your local authority's recycling service.



The materials can be recycled as per their symbols. Through the reuse, recycling of materials or other forms of recovery of old equipment, you make an important contribution to the protection of the environment.

## 7 RECOMMENDED ACCESSORIES

To make your training experience even more efficient and pleasant, we recommend that you add suiting accessories to your fitness equipment. For indoor cycles this could for example be a **floor mat**, which makes your fitness equipment stand more securely and also protects the floor from sweat or **silicone spray** to keep moving parts in good shape. For many indoor bikes it is possible to replace the **saddle** or **pedals**, as these are usually the same mounts used on bicycles.

If you have purchased a fitness machine with pulse training and want to train your heart rate, we strongly recommend that you use a compatible **chest strap**, as this ensures optimum transmission of the heart rate.

Our range of accessories offers the highest quality and makes training even better. If you would like to find out more about compatible accessories, please go to the detail page of the product in our webshop (the easiest way is to enter the article number in the search field above) and go to the recommended accessories on this page. Of course, you can also contact our customer service: by telephone, e-mail, in one of our branches or via our social media channels. We will be happy to advise you!



chest strap



floor mat



lubricant



## 8.1 Serial Number and Model Name

In order to provide you with the best possible service, please have the model name, article number, serial number, exploded drawing and parts list ready. The corresponding contact options can be found in chapter 10 of this operating manual.

**① NOTICE**

The serial number of your equipment is unique. It's located on a white sticker. The exact position of this sticker is shown in the following illustration.

Enter the serial number in the appropriate field.

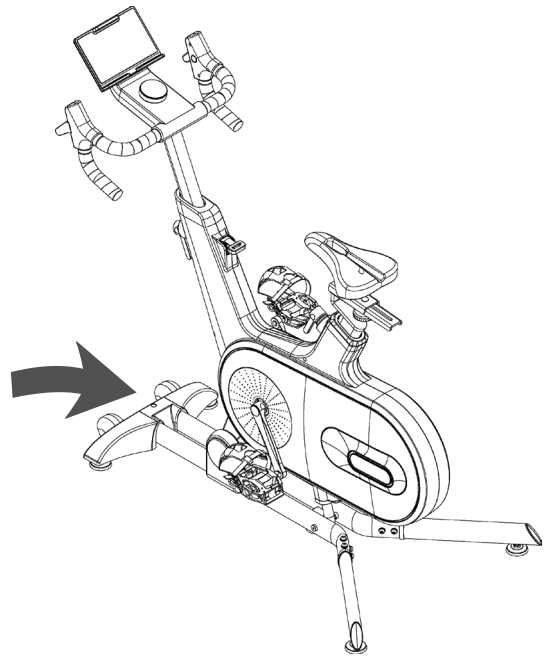

**Serial number:**

**Brand / Category:**

cardiostrong / indoor cycle

**Model Name:**

IB50

**SKU:**

CST-IB50

## 8.2 Parts List

No.	Name	Specification	Qty.
A01	Handrail tube assembly	weld assembly	1
A02	Instrument tube assembly	weld assembly	1
A03	Seat cushion tube assembly	weld assembly	1
A04	Seat cushion sliding plate assembly	weld assembly	1
A05	Main frame assembly	weld assembly	1
A06	Front footpad retaining plate assembly	weld assembly	1
A07	Base frame assembly	weld assembly	1
A08	Left rear foot tube assembly	weld assembly	1
A09	Right rear foot tube assembly	weld assembly	1
A10	Brake retainer plate assembly	weld assembly	1
B01	Left-hand crank	170, 9/16	1
B02	Right-hand crank	170, 9/16	1
B03	Screw nut	Φ36*11	2
B04	Knob top tight plate	φ23*t4.0	1
B05	Brake handle limit casing	Φ12*3.7	1
B06	Brake cable	L=854 stroke 47	1
B07	Brake spring	sizeφ1.3	1
B08	Powder metallurgy casing	φ54*18	2
B09	Bearing	6203-ZZ	2
B10	Bearing	6001-2RS	2
B11	Pressure belt wheel limit sleeve	Φ16*12.2*3.2	1
B12	L-shaped elastic pin assembly	M10*15	2
B13	Pull wire motor trimmer wire	L=578 stroke121	1
B14	Hex retaining bolts	Φ10 L=25mm	1
B15	Tension spring	φ0.5	2
B16	Straight mandrel assembly	φ17*170	1
B17	Equal length Allen wrench	5# S=5mm	1
B18	Cross wrench	S=13, 15	1
B19	Axis of rotation	φ25*78	1
C29	Adjustable foot pad	Φ56*M10*30	5
C30	Seat cushion	PU	1

C31	Moving wheel	Φ60*29	2
C32	D-shaped lampshade	19*33*60	2
C33	Oval cover	40.5**11*691	2
C34	Right protective cover	553*968*50	1
C35	Left protective cover	553*968*50	1
C36	Crank stopper	PP	2
C37	Turn the dot cap	86*86*18	2
C38	Turn point outer trim cover	157*110*27	2
C39	Turn point inside trim cover	110*92.5*5	2
C40	Turn the connecting cover R	204*160*51	1
C41	Turn the connecting cover L	204*160*48	1
C42	Front trim cover	65*137.4*43	1
C43	Seat cushion tube top tight block	Φ28*15	2
C44	Brake pad retaining seat	30*45*14.5	1
C45	Left pedal	9/16 screw thread	1
C46	Right pedal	9/16 screw thread	1
C47	Cowhide brake pad	25*41.5*4.0	1
C48	Foot tube spacer sleeve	65*35*11	2
C49	Handrail tube plug	φ32*16	2
C50	Handle strap	EVA	2
C51	Handle strap	EVA	2
D24	Flat washer Class C	6	4
D25	Standard type spring washer	10	1
D26	Standard type spring washer	8	11
D27	Corrugated spring washer	φ21x17.5x0.3t	1
D28	Hex pan head screws	M8*35	1
D29	Outer hex bolts	M10*30	1
D30	Extra large washer Class C	10	1
E01	Console		1
E02	Right shortcut keypad	3 chips L=460	1
E03	Left shortcut keypad upper segment	3 chips L=120	1
E04	controller		1
E05	Pin sensor	L=150mm	1

B20	Inner magnetic wheel	φ264/8KG	1
C01	Tablet top cover	209*133*7	1
C02	Tablet lower cover	209*149*41	1
C03	Tablet slide cover up	110*80*24.4	1
C04	Tablet sliding cover down	110*80*9.5	1
C05	Tablet holder silicone cover	199*125*2	1
C06	Console top cover	270*160*75.6	1
C07	Console lower cover	270*160*79.7	1
C08	Left handle bar cover L	127*84*24.5	1
C09	Left handle bar cover R	127*84*22.5	1
C10	Right handle bar decorative cover L	127*84*22.5	1
C11	Right handle bar cover R	127*84*24.5	1
C12	Speed button L	76*44*6.5	2
C13	Speed button support L	76*44*10.4	1
C14	Speed button R	76*44*6.5	1
C15	Speed button support R	76*44*10.4	1
C16	Key	22.3*20.5*7	2
C17	Driving belt	PJ495	1
C18	Instrument tube liner	80*40*134	1
C19	Seat tube liner	80*40*89.5	1
C20	Seat cushion sliding bushing	123*46.5*14.3	1
C21	Spinner Twist	51*51*42.5	1
C22	Brake handle	63*26*35	1
C23	Brake button	46*25*14.4	1
C24	Rear trim cover	30*65*110	1
C25	Belt reel	Φ240*20*Φ17	1
C26	Nylon press pulley	Φ14*21	1
C27	Oval diagonal pipe plug	30*60*20	2
C28	Front foot guard	420*136*71	1
D01	Countersunk head hex socket bolts	M12*30	1
D02	Square neck bolts	M8*30	1

D03	Hexagonal flange face lock female fine teeth	M10*1.25	2
D04	Type I non-metal insert hex lock nut	M8	4
D05	Type I non-metal insert hex lock nut	M6	4
D06	Hexagon flange face lock female	M10*1.0	2
D07	Hex pan head screws	M8*55	3
D08	Hex socket cylindrical head screw	M5*10	6
D09	Elastic stop ring for shaft - Type B	Φ17	2
D10	Hex socket flat round head screw	M8*15	9
D11	Hex pan head screw	M8*45	2
D12	Hex socket cylindrical head screw	M6*12	9
D13	Hex socket flat round head screw	M10*100	1
D14	Cross recessed pan head self-tapping self-drilling screw	ST4.2*12	8
D15	Cross recessed pan head tapping screw	ST4.2*12	24
D16	Cross pan head self-tapping screw	ST3.5*10	10
D17	Cross recessed pan head tapping screw	ST2.9*8	16
D18	Cross recessed pan head tapping screw	ST2.9*6.5	8
D19	Cross recessed countersunk head tapping screw	ST2.9*6.5	9
D20	Cross recessed countersunk head tapping screw	ST2.9*5.5	4
D21	Flat washer Class C	10	1
D22	Flat washer Class C	8	13
D23	Large washer Class C	6	1
E06	Pull wire motor	L=100mm	1
E07	LED light board R	wire L=300mm, light L=150mm	1
E08	LED light board L	wire L=800mm, light L=150mm	1
E09	Pull wire motor connection wire	5 chips L=100mm white	1
E10	Upper segment wire	5 chips L=100mm red	1
E11	Lower section of the left shortcut keyplate	3 chips L=400	1
E12	DC incline motor	stroke 60mm	1
E13	Lower segment wire	5 chips L=1200mm	1
E14	Power plug female socket	L=300mm	1
E15	B module		1
E16	Power adapter	24V	1

# 8.3 Exploded Drawing

B18	
B17	
E09	
E10	
E11	
E13	
E14	
E15	

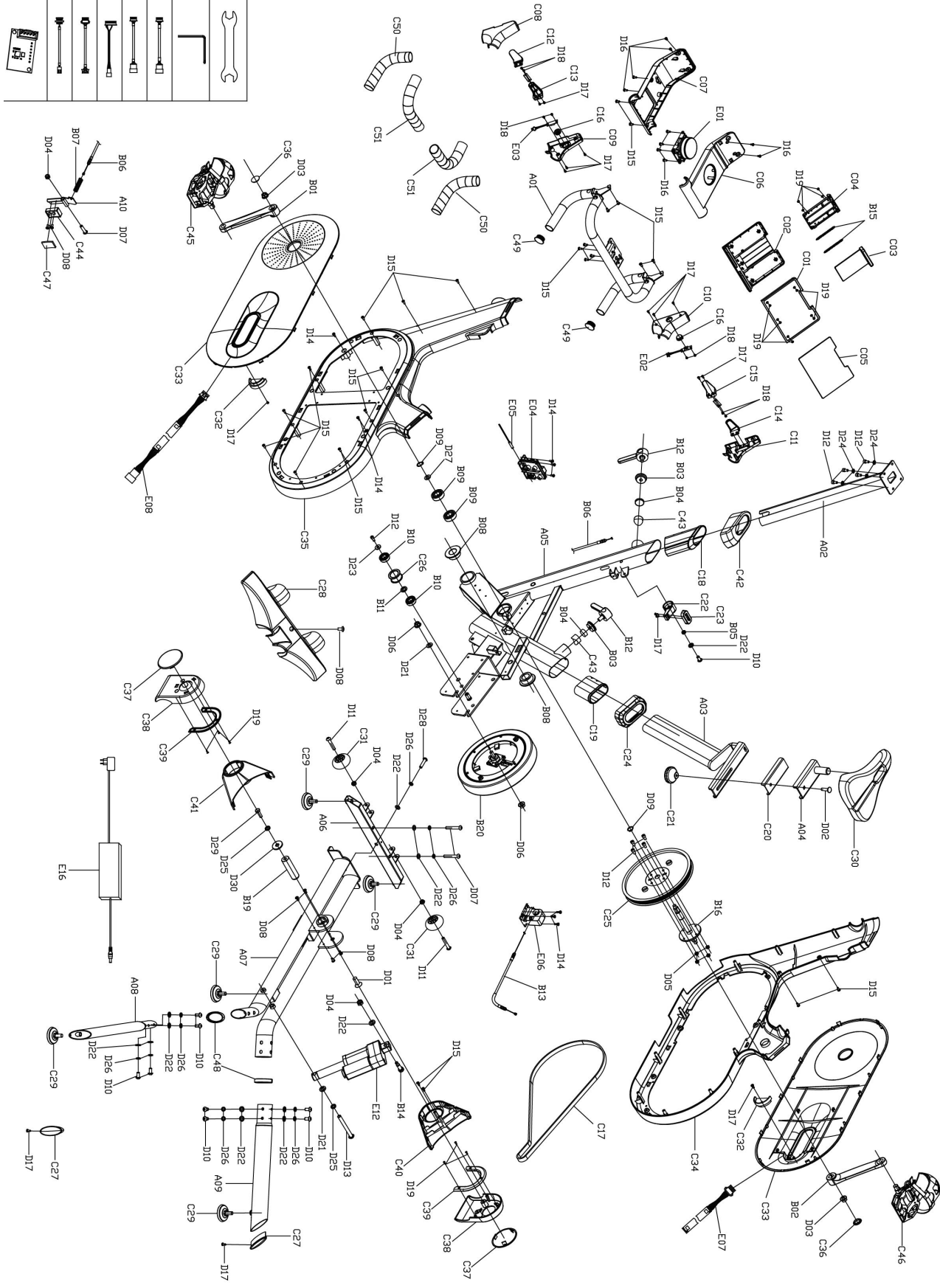

Products from TAURUS® are subject to strict quality control. However, if a fitness equipment purchased from us does not work perfectly, we take it very seriously and ask you to contact our customer service as indicated. We are happy to help you by phone via our service hotline.

### **Error Descriptions**

Your fitness equipment is developed for long-term, high-quality training. However, should a problem arise, please first read the operating instructions. For further assistance, please contact your contract partner or call our service hotline. To ensure your problem is solved as quickly as possible, please describe the defect as exactly as possible.

In addition to the statutory warranty, we provide a warranty for every fitness equipment purchased from us according to the following provisions.

**Your statutory rights are not affected.**

### **Warrantee**

The warrantee is the first/original buyer.

### **Warranty periods**

The following warranty periods begin on delivery of the fitness equipment.

#### **Warranty period**

The warranty periods, shown on our web shop, begin on delivery of the fitness equipment. The respective warranty periods for your equipment can be found on its product website.

### **Repair Costs**

According to our choice, there will either be a repair, a replacement of individual damaged parts or a complete replacement. Spare parts, that have to be mounted while assembling the equipment, have to be replaced by the warrantee personally and are not a part of repair. After the expiration of the warranty period, the responsibility for parts costs, repair costs, installation costs and delivery costs lies with the warranty holder.

### **The terms of use are defined as follows:**

- + Home use: solely for private use in private households up to 3 hours per day
- + Semi-professional use: up to 6 hours per day (e. g. rehabilitation centres, hotels, clubs, company gyms)
- + Professional use: more than 6 hours per day (e. g. commercial gyms)

## **Warranty Service**

Within the warranty period, equipment which develops faults as a result of material or manufacturing defects, will be repaired or replaced at our discretion. Ownership of equipment or parts of equipment which have been replaced is transferred to us. The warranty period is not extended nor does a new warranty period begin following repair or replacement under the warranty.

## **Warranty Conditions**

For the warranty to be valid, the following steps must be taken:

Please contact our customer service by email or phone. If the product under warranty has to be sent in for repair, the seller bears costs. After expiry of the warranty, the buyer bears the costs of transport and insurance. If the fault is covered by our warranty, you will receive a new or repaired equipment in return.

## **Warranty claims are invalid in case of damage resulting from:**

- + misuse or improper handling
- + environmental influences (moisture, heat, electrical surge, dust, etc.)
- + failure to follow the current safety measures for the equipment
- + failure to follow the operating instructions
- + use of force (e. g. hitting, kicking, falling)
- + interventions which were not carried out by one of our authorized service centres
- + unauthorised repair attempts

## **Proof of Purchase and Serial Number**

Please make sure that you are able to provide the appropriate receipt when claiming on your warranty. So that we can clearly identify the model of your equipment, and for the purposes of our quality control, you will need to give the serial number of your equipment, when contacting the service team. Where possible please have your serial number and your customer number ready when you call our service hotline. It will help us to deal with your request swiftly.

If you cannot find the serial number on your fitness equipment, our service team is at your disposal to offer further information.

## **Service outside of the Warranty Period**







































We are also happy to issue an individual cost estimate if there is a problem with your fitness equipment after the warranty has expired, or in cases which do not fall under the terms of the warranty, e. g. normal wear and tear. Please contact our customer service team to find a quick and cost-effective solution to your problem. In such a case you will be responsible for the delivery costs.

## **Communication**

Many problems can be solved just by speaking to us as your specialist supplier. We know how important it is to you as a user of the fitness equipment to have problems solved quickly and simply, so you can enjoy working out with minimal interruption. For that reason, we also want to resolve your queries quickly and in a straightforward manner. Thus, please always keep your customer number and the serial number of the faulty equipment handy.



## 10 CONTACT

DE	DK	UK
<p><b>TECHNIK</b></p> <p> +49 4621 4210-900</p> <p> +49 4621 4210-698</p> <p> <a href="mailto:technik@fitshop.de">technik@fitshop.de</a></p> <p> Öffnungszeiten entnehmen Sie unserer Homepage.</p> <p><b>SERVICE</b></p> <p> 0800 20 20277 (kostenlos)</p> <p> 04621 4210 - 0</p> <p> <a href="mailto:info@fitshop.de">info@fitshop.de</a></p> <p> Öffnungszeiten entnehmen Sie unserer Homepage: <a href="https://stg.fit/statita">https://stg.fit/statita</a></p>	<p><b>TEKNIK OG SERVICE</b></p> <p> 80 90 16 50</p> <p>+49 4621 4210-945</p> <p> <a href="mailto:info@fitshop.dk">info@fitshop.dk</a></p> <p> Åbningstider kan findes på hjemmesiden: <a href="https://stg.fit/statit7">https://stg.fit/statit7</a></p>	<p><b>CUSTOMER CARE</b></p> <p> +44 141 737 2249 or +44 141 876 3972</p> <p> <a href="mailto:customercare@fitshop.co.uk">customercare@fitshop.co.uk</a></p> <p> You can find the opening hours on our homepage: <a href="https://stg.fit/statitd">https://stg.fit/statitd</a></p>
	FR	BE
	<p><b>TECHNIQUE &amp; SERVICE</b></p> <p> +33 (0) 189 530984</p> <p>+49 4621 42 10 933</p> <p> <a href="mailto:info@fitshop.fr">info@fitshop.fr</a></p> <p> Vous trouverez les heures d'ouverture sur notre site Internet: <a href="https://stg.fit/statit4">https://stg.fit/statit4</a></p>	<p><b>TECHNIQUE &amp; SERVICE</b></p> <p> 02 732 46 77</p> <p>+49 4621 4210 933</p> <p> <a href="mailto:info@fitshop.be">info@fitshop.be</a></p> <p> Vous trouverez les heures d'ouverture sur notre site Internet: <a href="https://stg.fit/statit8">https://stg.fit/statit8</a></p>
ES	NL	INT
<p><b>TECNOLOGÍA Y SERVICIOS</b></p> <p> 911 238 029</p> <p> <a href="mailto:info@fitshop.es">info@fitshop.es</a></p> <p> Consulta nuestro horario de apertura en la página web: <a href="https://stg.fit/statit5">https://stg.fit/statit5</a></p>	<p><b>TECHNISCHE DIENST &amp; SERVICE</b></p> <p> +31 172 619961</p> <p> <a href="mailto:service@fitshop.nl">service@fitshop.nl</a></p> <p> De openingstijden vindt u op onze homepage: <a href="https://stg.fit/statit3">https://stg.fit/statit3</a></p>	<p><b>TECHNICAL SUPPORT &amp; SERVICE</b></p> <p> +49 4621 4210-944</p> <p> <a href="mailto:service-int@fitshop.de">service-int@fitshop.de</a></p> <p> You can find the opening hours on our homepage: <a href="https://stg.fit/statita">https://stg.fit/statita</a></p>
PL	AT	CH
<p><b>DZIAŁ TECHNICZNY I SERWIS</b></p> <p> 22 307 43 21</p> <p>+49 4621 42 10-948</p> <p> <a href="mailto:info@fitshop.pl">info@fitshop.pl</a></p> <p> Godziny otwarcia można znaleźć na stronie głównej: <a href="https://stg.fit/statit6">https://stg.fit/statit6</a></p>	<p><b>TECHNIK &amp; SERVICE</b></p> <p> 0800 20 20277 (Freecall)</p> <p>+49 4621 42 10-0</p> <p> <a href="mailto:info@fitshop.at">info@fitshop.at</a></p> <p> Öffnungszeiten entnehmen Sie unserer Homepage: <a href="https://stg.fit/statitb">https://stg.fit/statitb</a></p>	<p><b>TECHNIK &amp; SERVICE</b></p> <p> 0800 202 027</p> <p>+49 4621 42 10-0</p> <p> <a href="mailto:info@fitshop.ch">info@fitshop.ch</a></p> <p> Öffnungszeiten entnehmen Sie unserer Homepage: <a href="https://stg.fit/statit9">https://stg.fit/statit9</a></p>

Please find a detailed overview including address and opening hours for all stores of Fitshop UK on the following website:

[www.fitshop.co.uk/storelocator](http://www.fitshop.co.uk/storelocator)

# WE LIVE FITNESS

## WEBSHOP AND SOCIAL MEDIA

The Fitshop Group is Europe's largest specialist for home fitness equipment with currently 70 stores and one of the world's most renowned online mail order companies for fitness equipment.

Fitshop UK is part of the Fitshop Group. Private customers order via the 25 web shops in the respective national language or have their desired equipment assembled on site. In addition, the company supplies fitness studios, hotels, sports clubs, companies and physio practices with professional equipment for endurance and strength training.

The Fitshop group offers a wide range of fitness equipment from renowned manufacturers, high-quality in-house developments and comprehensive services, such as a build-up service and sports scientific advice before and after the purchase. The company employs numerous sports scientists, fitness trainers and competitive athletes.

Visit us also on our social media platforms or our blog!

**FIT  
SHOP**

<https://www.fitshop.co.uk/>  
[www.fitshop.co.uk/blog/](http://www.fitshop.co.uk/blog/)



[www.facebook.com/fitshop.co.uk](http://www.facebook.com/fitshop.co.uk)



[www.instagram.com/fitshop\\_uk](http://www.instagram.com/fitshop_uk)



[www.youtube.com/@fitshop\\_uk](http://www.youtube.com/@fitshop_uk)

**TAURUS**

 cardiostrong

*BODYCRAFT*

**BodyMax**





**Cardiostrong IB50**