

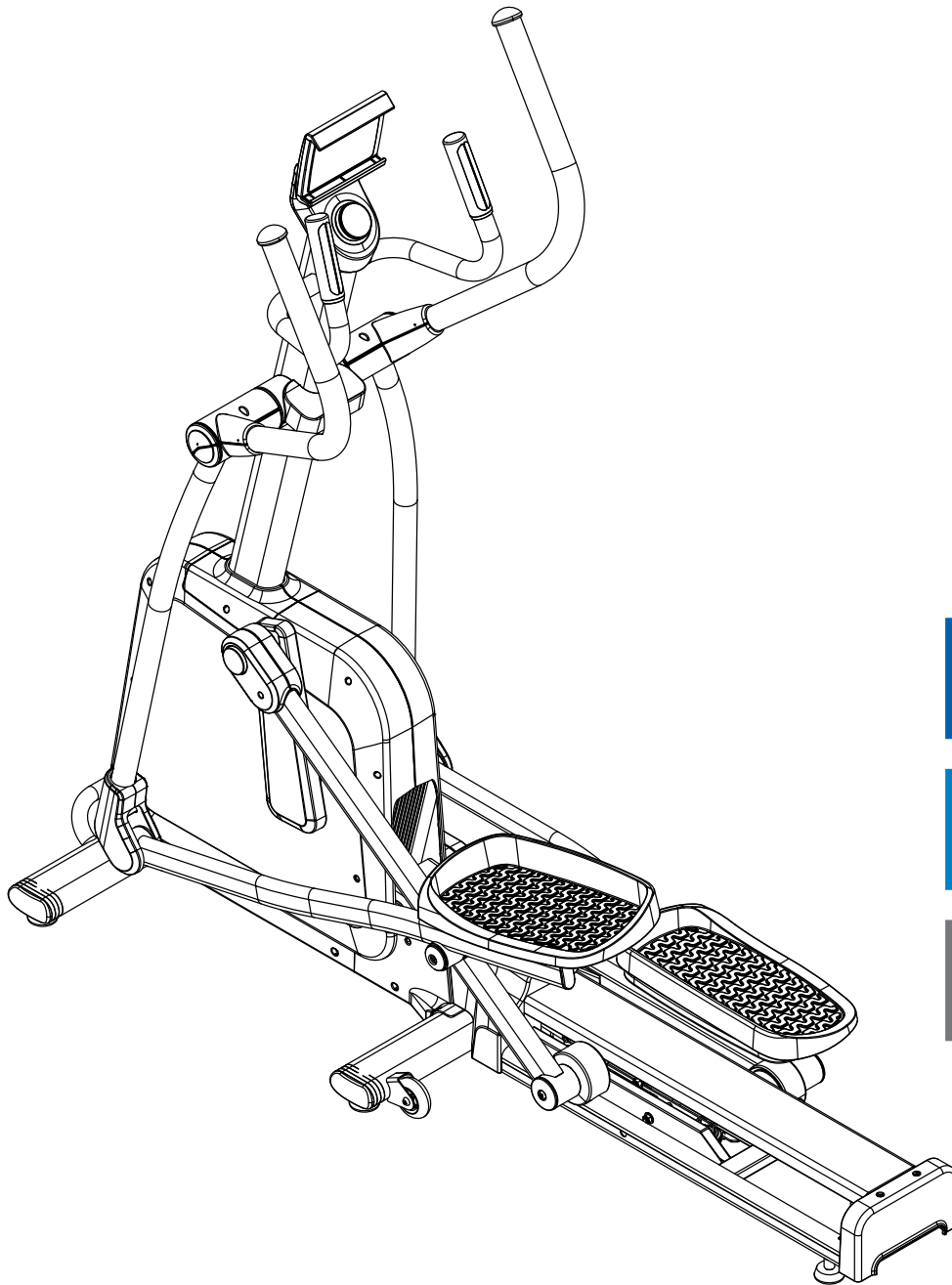

Assembly and Operating Instructions



max. 150 kg



~ 90 Min.



33 kg

L 70 | W 183 | H 171

FSUKCSTFX50.01.02

SKU: CST-FX50

Crosstrainer FX50

Content

1	GENERAL INFORMATION	8
1.1	Technical Data	8
1.2	Personal Safety	9
1.3	Electrical Safety	10
1.4	Set-Up Place	11
2	ASSEMBLY	12
2.1	General Instructions	12
2.2	Scope of Delivery	13
2.3	Assembly	16
2.4	Folding Mechanism	25
3	OPERATING INSTRUCTIONS	26
3.1	Console display	26
3.2	Button functions	27
3.3	Programmes	28
3.3.1	Quick-Start and Manual Mode	28
3.4	Wireless Connection and Fitness Apps	29
4	STORAGE AND TRANSPORT	30
4.1	General Instructions	30
4.2	Transportation Wheels	30
5	TROUBLESHOOTING, CARE AND MAINTENANCE	31
5.1	General Instructions	31
5.2	Faults and Fault Diagnosis	31
5.3	Error Codes and Troubleshooting	32
5.4	Maintenance and Inspection Calendar	33
6	DISPOSAL	33
7	RECOMMENDED ACCESSORIES	34
8	ORDERING SPARE PARTS	35
8.1	Serial Number and Model Name	35
8.2	Parts List	36
8.3	Exploded Drawing	43

9	WARRANTY	45
10	CONTACT	47

Dear customer,

thank you for choosing fitness equipment from cardiostrong®. cardiostrong offers high-quality home fitness equipment that is optimally adapted to the conditions at home. Train at home no matter what the weather or time of the day. cardiostrong fitness equipment offers training programmes and a variety of equipment for all training levels and all training goals. Further information can be found at www.fitshop.com or www.cardiostrong.de. We hope you enjoy your training!

Further information can be found at www.fitshop.co.uk

Intended Use

The equipment may only be used for its intended purpose.

The equipment is only suitable for home use. The equipment is not suitable for semi-professional (e.g. hospitals, associations, hotels, schools, etc.) and commercial or professional use (e.g. fitness studios).

Legal Notice

Fitshop GmbH
Europe's No. 1 for home fitness

International Headquarters
Flensburger Straße 55
24837 Schleswig
Germany

Management:
Christian Grau
Sebastian Campmann
Dr. Bernhard Schenkel
No. HRB 1000 SL
Local Court Flensburg
European VAT Number: DE813211547

Disclaimer

© cardiostrong is a registered brand of the company Fitshop GmbH. All rights reserved. Any use of this trademark without the explicit written permission of Fitshop is prohibited.

Product and manual are subject to change. Technical data can be changed without advance notice.

FITSHOP

Europe's No.1 for Home Fitness

ABOUT THIS MANUAL

Please carefully read the entire manual before installation and first use. The manual will help you to quickly set up the system and explains how to safely use it. Make sure that all persons exercising with the equipment (especially children and persons with physical, sensory, mental or motor disabilities) are informed about this manual and its contents in advance. In case of doubt, responsible persons must supervise the use of the equipment.

Due to ongoing changes and software optimisations, the manual may have to be updated. If you notice any discrepancies during assembly or use, please refer to the manual uploaded to the webshop. The latest manual is always available there.



This equipment has been manufactured according to the latest safety knowledge. As far as possible, potential safety hazards which could cause injury have been eliminated. Make sure to carefully follow the instructions and that all parts are securely in place. If required, read through the instructions again to correct any mistakes.

Training devices must be classified according to accuracy and use. Accuracy classes are only applicable to devices that display training data.

Accuracy classes

Class A: high accuracy.

Class B: medium accuracy.

Class C: low accuracy.

The use classes explain the intended use of the training device.

Use classes

Class S (studio): professional and/or commercial use.

These training devices are intended for the use in training rooms of facilities such as sports clubs, school facilities, hotels, clubs and studios whose access and supervision is specifically regulated by the owner (person with legal responsibility).

Class H (home use): use at home.

These stationary training devices are intended for the use in private homes where access to the training device is regulated by the owner (person with legal responsibility).

Please pay close attention to the safety and maintenance instructions given here. The contract partner cannot be held liable for damage to health, accidents or damage to the equipment when it is not used in accordance with these instructions.

The following safety instructions may appear in this manual:

► **ATTENTION**

This notice indicates potentially hazardous situations which, if not avoided, may result in property damage.

⚠ **CAUTION**

This notice indicates potentially hazardous situations which, if not avoided, may result in slight or minor injuries!

⚠ **WARNING**

This notice indicates potentially hazardous situations which, if not avoided, may result in death or serious injuries!

⚠ **DANGER**

This notice indicates potentially hazardous situations which, if not avoided, will result in death or serious injuries!

ⓘ **NOTICE**

This notice indicates further useful information.

Retain these instructions in a safe place for future reference, maintenance or when ordering replacement parts.

1.1 Technical Data

TFT display of

- + speed in km/h
- + training time in min
- + training distance in km
- + cadence (rotations per minute)
- + calories burnt in kcal
- + heart rate (when using the hand sensors or a chest strap)
- + Watt
- + resistance level

Resistance system: electronic magnetic brake system
Resistance level: 32

Quick Start programme: 1
Manual programmes: 1

Balance mass: 8 kg
Stride length: 50.8 cm

Weight and dimensions:

Article weight (gross, including packaging): 87.9 kg
Article weight (net, without packaging): 79.4 kg
Packaging dimensions (L x W x H) approx.: 186 cm x 46 cm x 87 cm
Set-up dimensions (L x W x H) approx.: 70 cm x 183 cm x 171 cm

Maximum user weight: 150 kg

Use class: H

1.2 Personal Safety

DANGER

- + Before you start using the equipment, you should consult your physician that this type of exercise is suitable for you from a health perspective. Particularly affected are persons who: have a hereditary disposition to high blood pressure or heart disease, are over the age of 45, smoke, have high cholesterol values, are overweight and/or have not exercised regularly in the past year. If you are under medical treatment that affects your heart rate, medical advice is absolutely essential.
- + Note that excessive training can seriously endanger your health. Please also note that heart rate monitoring systems can be inaccurate. If you notice any signs of weakness, nausea, dizziness, pain, shortness of breath, or other abnormal symptoms, stop exercising immediately and seek advice from your doctor if necessary.
- + The owner must communicate all warnings and instructions to the user.

WARNING

- + This equipment may not be used by children under the age of 14.
- + Children should not be allowed unsupervised access to the equipment.
- + Persons with disabilities must have a medical license and must be under strict observation when using the equipment.
- + Remember that your device does not have a freewheel function. Therefore moving parts cannot be stopped immediately.
- + Note that the individual physical power required to perform an exercise may differ from the displayed mechanical power.
- + When ascending and descending, make sure that one of the treads is in the lowest position.
- + The equipment is strictly for use by one person at a time.
- + Keep your hands, feet and other body parts, hair, clothing, jewellery and other objects well clear of moving parts.
- + During use, wear suitable sports clothing rather than loose or baggy clothing. When wearing sports shoes, make sure they have suitable soles, preferably made of rubber or other non-slip materials. Shoes with heels, leather soles, studs or spikes are unsuitable. Never exercise barefoot.

CAUTION

- + If your equipment needs to be connected to the power supply with a mains cable, make sure that the cable is not a potential tripping hazard.
- + Make sure that nobody is within the range of motion of the equipment during training so as not to endanger you or other persons.
- + Do not insert any objects of any kind into the openings of the device.
- + Be aware that if adjustment devices are left protruding, they may impede the user's movement.

1.3 Electrical Safety

DANGER

- + In order to reduce the risk of an electric shock, always unplug the equipment from the mains socket immediately after your workout, before assembly or dismantling, and before maintenance or cleaning. Do not pull on the cable.

WARNING

- + Do not leave the equipment unattended while the mains cable is plugged into the mains socket. During your absence, the mains cable must be removed from the mains socket to prevent improper use by third parties or children.
- + If the mains cable or plug is damaged or defective, contact your contract partner. Until repair, the equipment must not be used.

ATTENTION

- + The equipment requires a mains connection of 220-230 V with 50 Hz mains voltage.
- + The equipment may only be connected directly to an earthed socket using the supplied mains cable. Extension cables must conform to VDE guidelines. Always completely unwind the mains cable.
- + The socket must be protected by a fuse with a minimum fuse rating of "16 A, slow blow".
- + Do not make any changes to the mains cable or the mains plug.
- + Keep the mains cable away from water, heat, oil and sharp edges. Do not route the mains cable underneath the equipment or under a carpet or rug, and do not place any objects on top of it.
- + If your purchased item is equipped with a TFT console, software updates must be carried out regularly. Follow the instructions on the console to perform the update(s).
- + The software systems on gym equipment with TFT consoles are set up only for the pre-installed apps. Do not install any additional apps.

NOTICE

- + The pre-installed apps on TFT consoles are produced and provided by external manufacturers. Fitshop does not take any responsibility for the availability, functionality or contents of these apps.

1.4 Set-Up Place

WARNING

- + Do not place the equipment in main corridors or escape routes.

CAUTION

- + Choose a location in which to place the equipment such that there is enough free space/clearance to the front, the rear and to the sides of the equipment.
- + The training room should be well ventilated during training and not be exposed to any draughts.
- + Choose the place in which to set up the equipment such that there is enough free space/clearance to the front, the rear and to the sides of the equipment.
- + The free area in the direction from which the exercise equipment is accessed must be at least 0.6 m larger than the exercise area.
- + The set-up and mounting surface of the equipment should be flat, loadable and solid.

ATTENTION

- + The device may only be used in one building, in sufficiently tempered and dry rooms (ambient temperatures between 10°C and 35°C). The equipment should not be used outdoors or in rooms with high humidity (over 70%) like swimming pools.
- + A floor protective mat/equipment underlay can help to protect high-quality floor coverings (parquet, laminate, cork, carpets) from dents and sweat and can help to level out slight unevenness.
- + For Class S equipment, the exercise equipment may only be used in areas where access, supervision and control are specifically regulated by the owner.

2.1 General Instructions



DANGER

- + Do not leave any tools, packaging materials such as foils or small parts lying around, as otherwise there is a danger of suffocation for children. Keep children away from the equipment during assembly.



WARNING

- + Pay attention to the instructions attached to the equipment in order to reduce the risk of injuries.



CAUTION

- + Ensure to have sufficient room for movement in each direction during assembly.
- + The assembly of the equipment must be carried out by at least two adults. If in doubt, seek the help of a third technically skilled person.



ATTENTION

- + To prevent damage to the equipment and the floor, assemble the equipment on a mat or packaging board.



NOTICE





- + In order to make the assembly as simple as possible, some screws and nuts to be used can already be pre-assembled.
- + Ideally, assemble the equipment at its later set-up place.

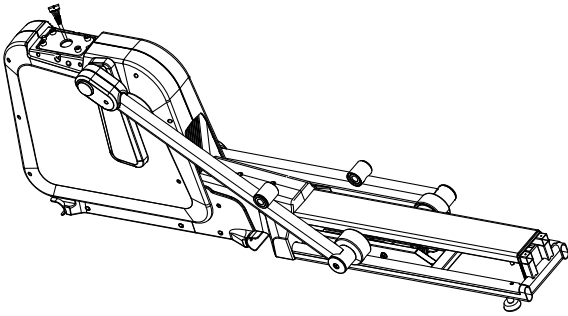
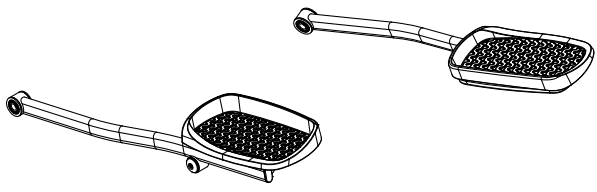
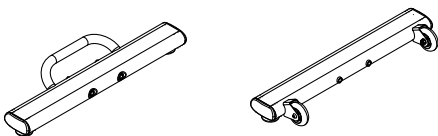
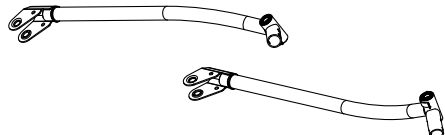
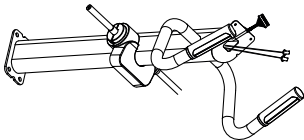
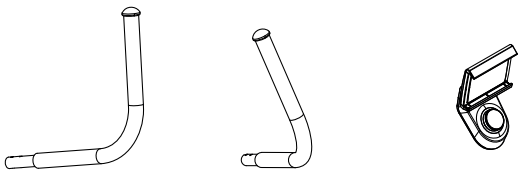

2.2 Scope of Delivery

The scope of delivery consist of the following parts. At the beginning, check whether all parts and tools belonging to the device are included in the scope of delivery and whether damage has occurred. In the event of complaints, the contractual partner must be contacted directly.

 **CAUTION**

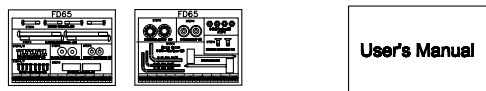
If parts of the scope of delivery are missing or damaged, the assembly must not be carried out.

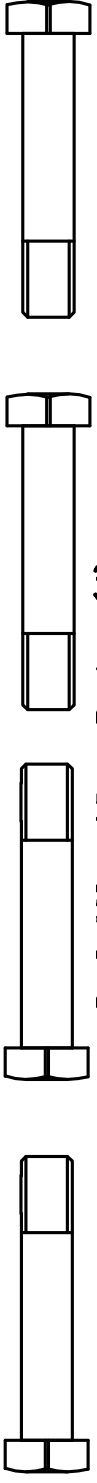
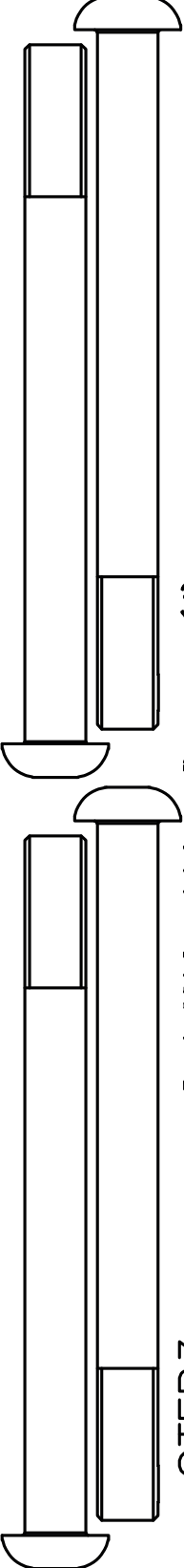
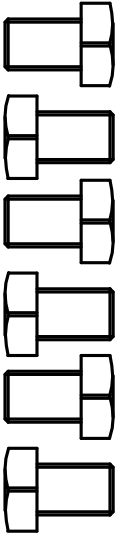
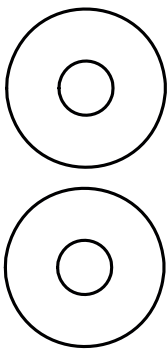
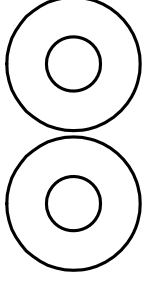
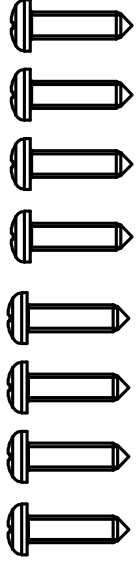
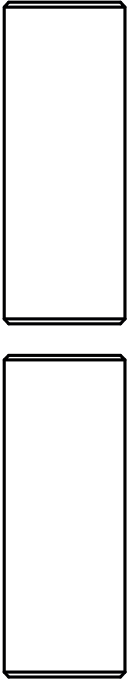
 <p>STEP6</p> <p>R-2 M8 × 45mm Bolt (4)</p>	 <p>STEP3</p> <p>R-1 M10 × 114mm Screw (4)</p>	<p>STEP5/6</p>  <p>R-5 M8 × 12mm Screw (6)</p> <p>STEP5</p>  <p>R-4 M8 × 25mm Washer (2)</p> <p>STEP6</p>  <p>R-6 M8 × 21mm Washer (4)</p>	<p>STEP4/7</p>  <p>R-9 M4 × 16mm Screw (8)</p> <p>STEP6</p>  <p>R-7 Pedal Arm Axle (2)</p>	
--	---	---	---	--

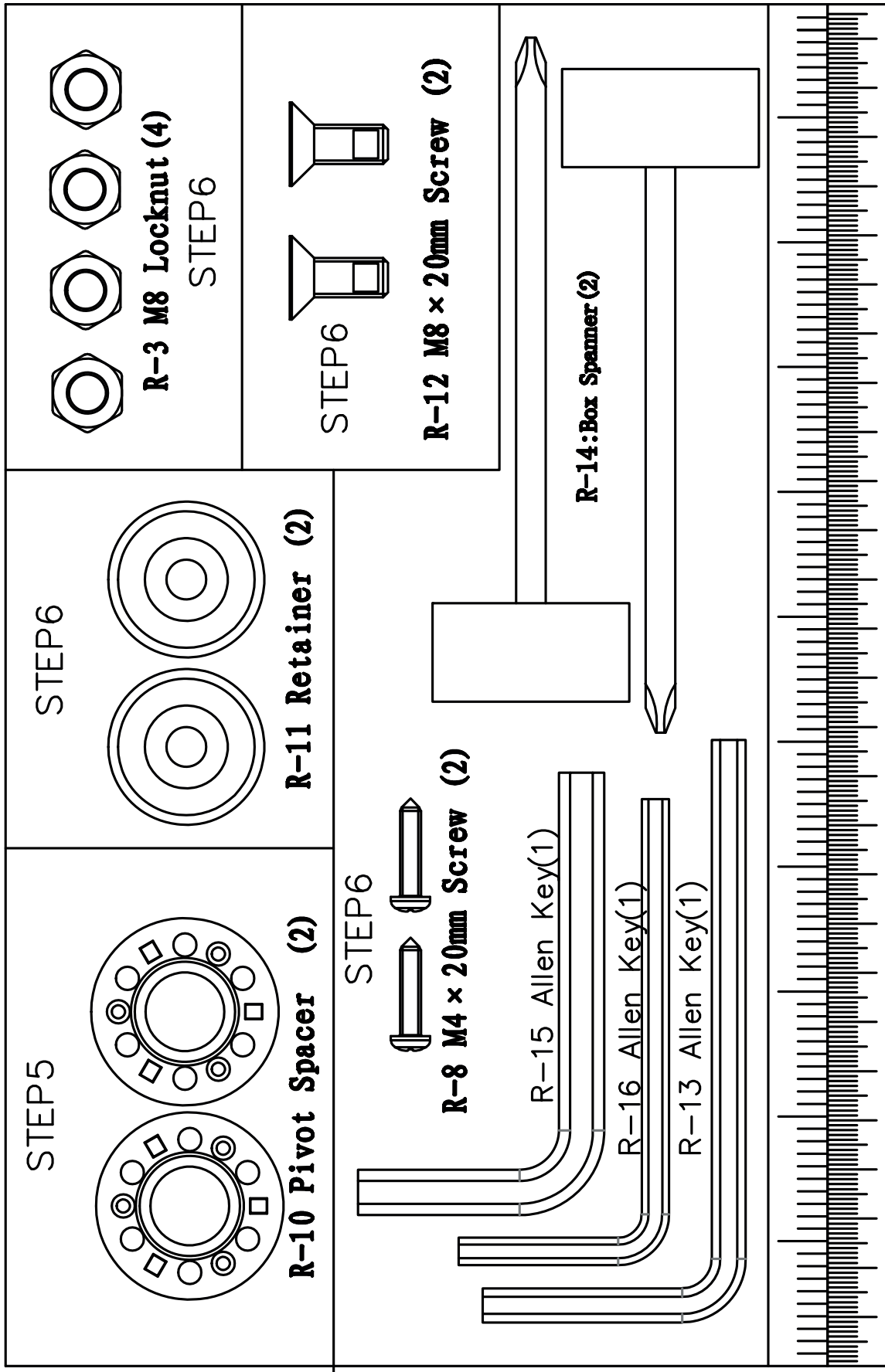

2.3 Assembly

Before assembly, take a close look at the individual assembly steps shown and carry out the assembly in the order given.

① NOTICE

- + First loosely screw all parts together and check that they fit properly. Tighten the screws using the tool only when you are instructed to do so.
- + If you have difficulty recognising the graphics, we recommend that you open and/or download the PDF instructions stored in the webshop on your end device (e.g. smartphone, tablet or PC). There you have the option of zooming in closer. Please note that the Adobe Acrobat Reader programme must be installed on your end device in order to open the file.

Step 1

1. Use the packaging styrofoam to appropriately raise the main frame (J) and make the assembly easier.
2. Remove the two screws (J-55).

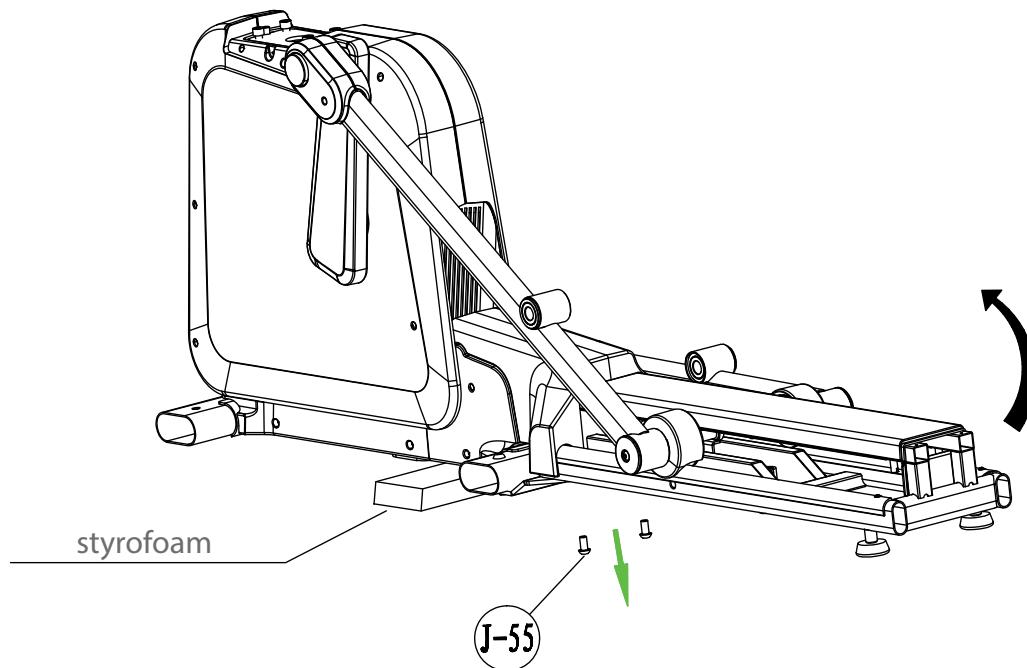

Step 2

Remove the four screws (J-42/J-54), the tube (J-41) and joint plate for main frame (J-53).

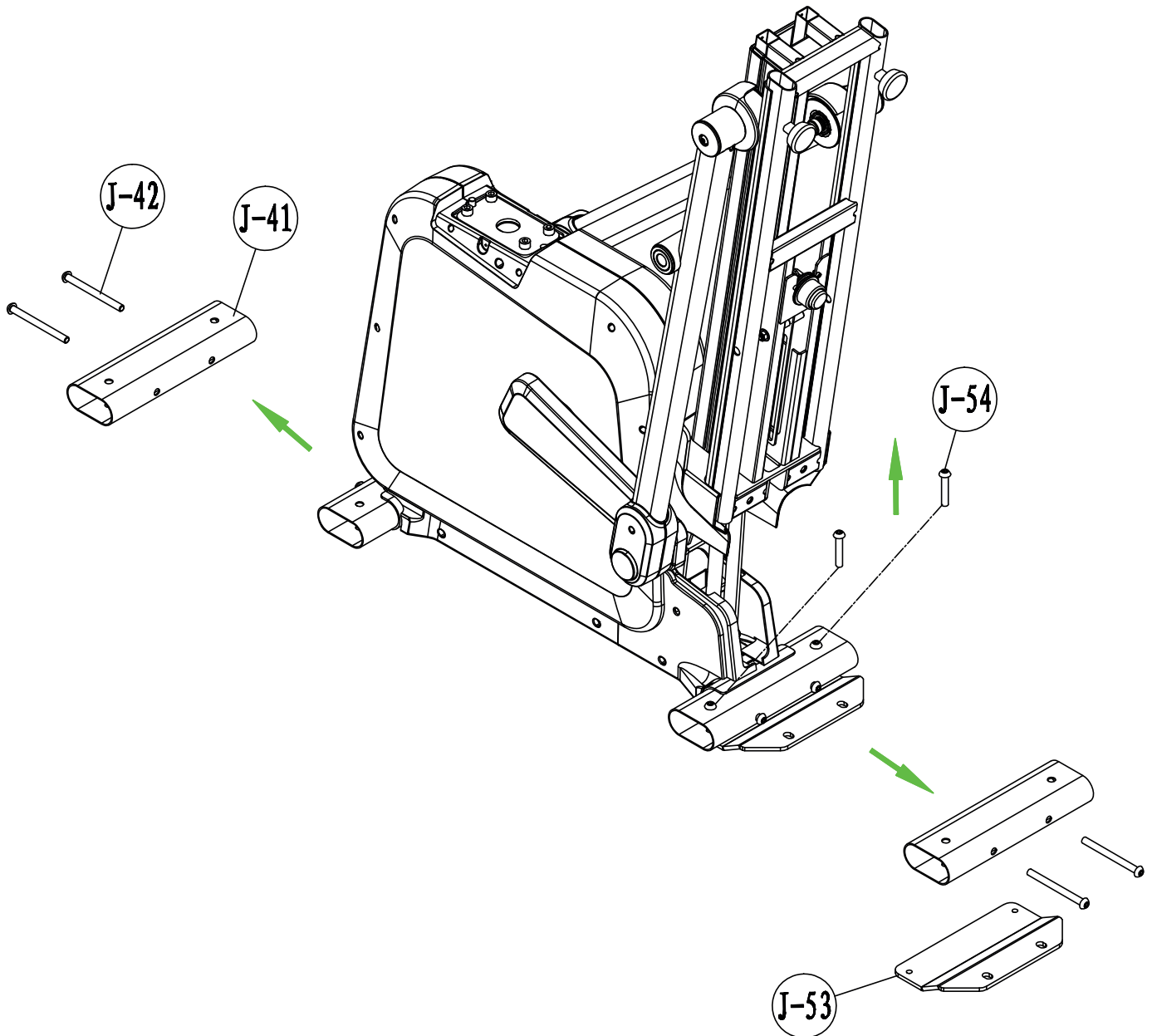

Step 3

Assemble the front stabilizer (L) and the middle stabilizer (M) with two screws (R-1) each.

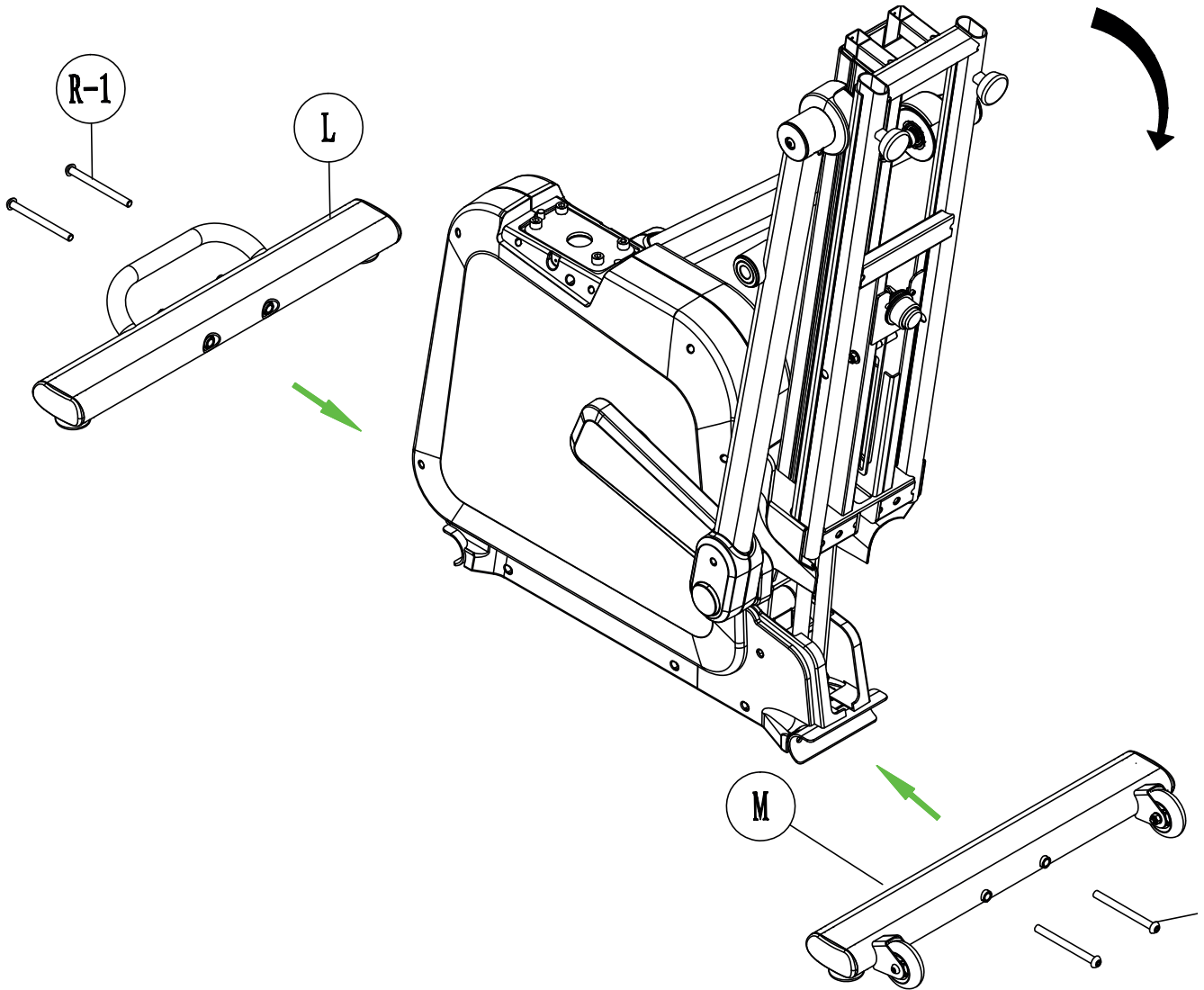

Step 4

1. Connect the two console cables (J-27 & L6).
2. Assemble the handlebar post (L) with four screws (J-1).
3. Assemble the left cap of the handlebar post (S-7) and the right cap of handlebar post (S-8) with one screw (R-9) each.
4. Assemble the cover for rear stabilizer (S-9) with two screws (R-9).

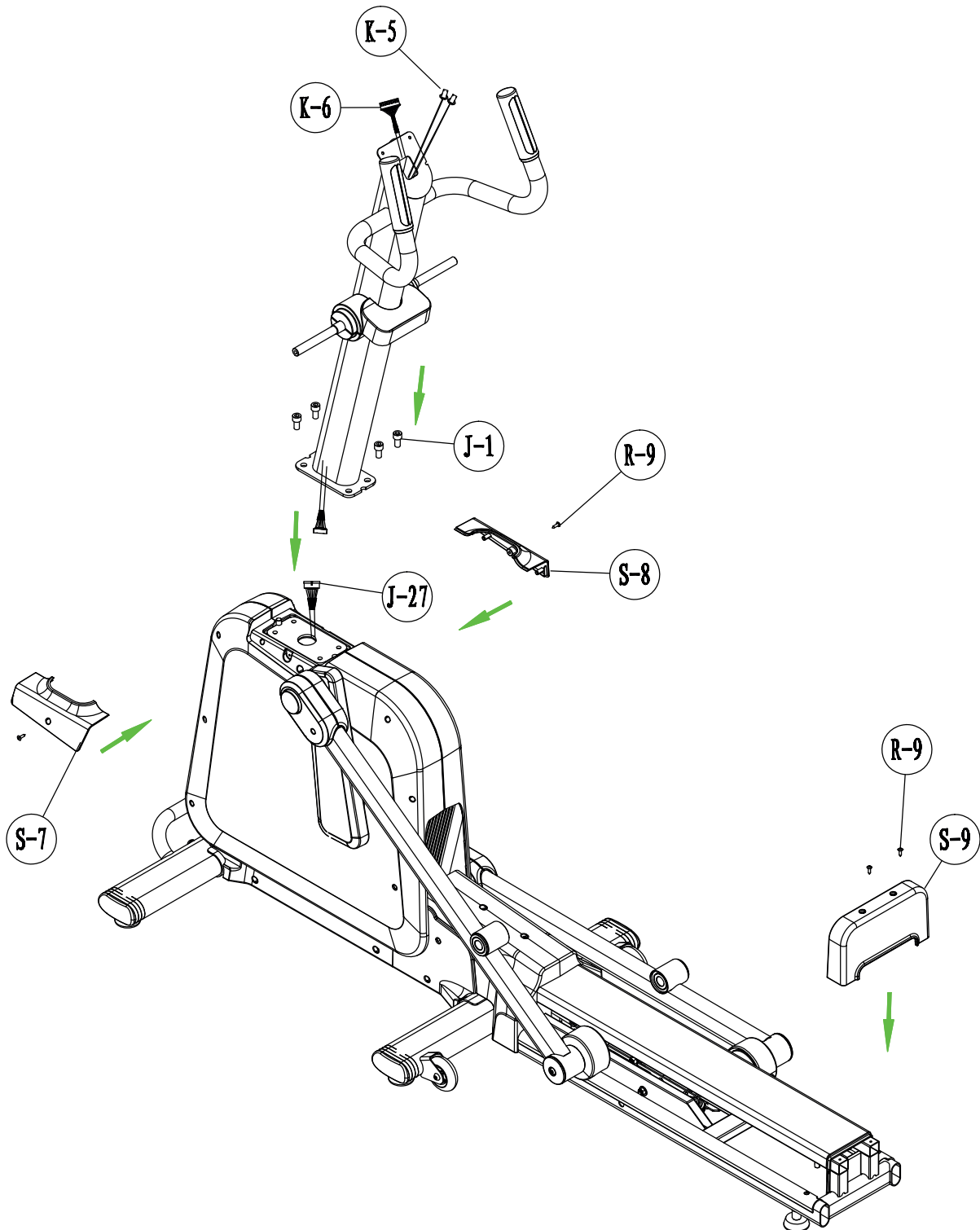

Step 5

Assemble the left and right lower handlebar (P & Q) to the axle of the handlebar post (K) using the bushing (R-10), two flat washers (R-4) and two hex. screws (R-5) in total.

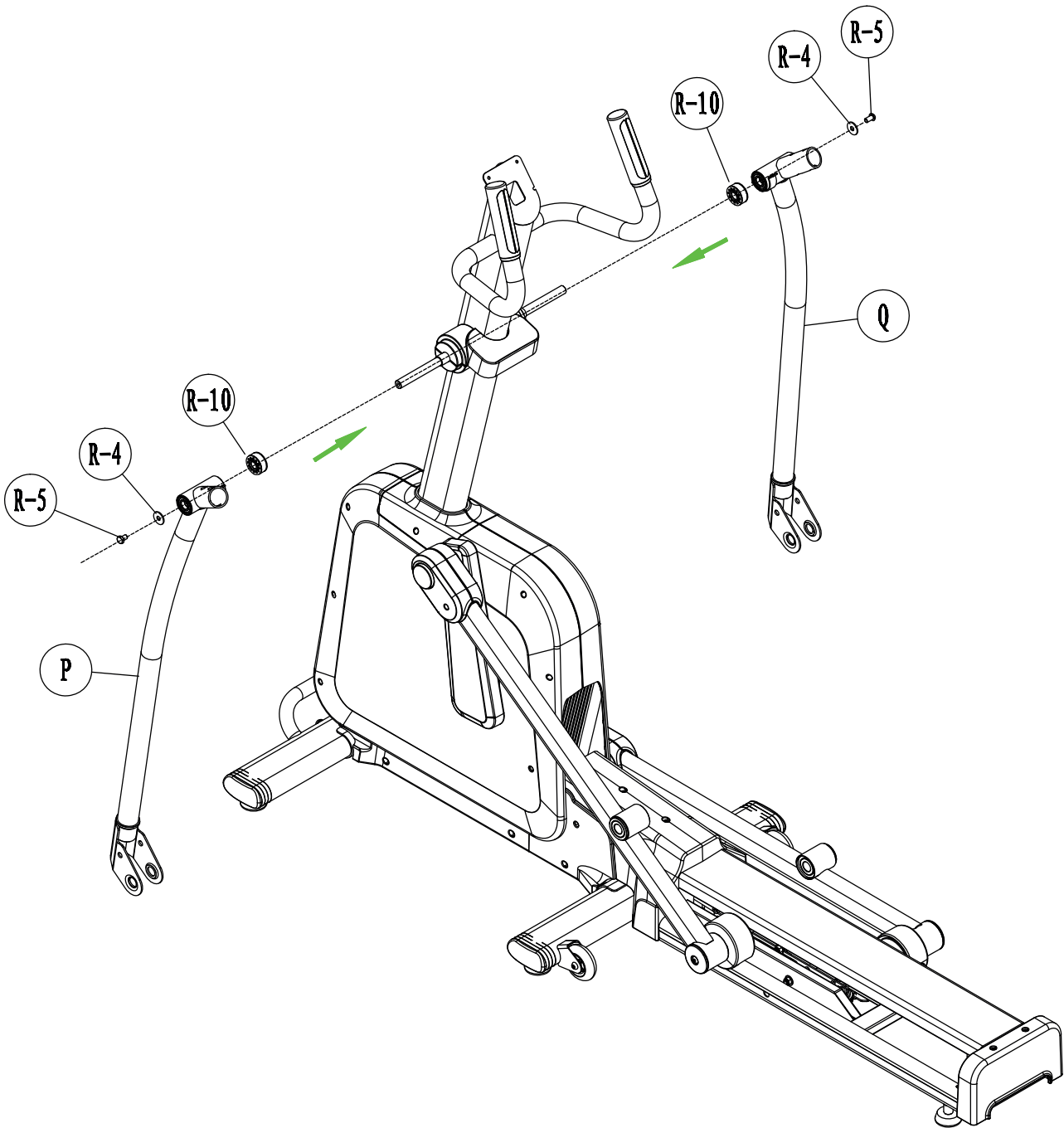

Step 6

1. Assemble the two pedal arms (E & F) to the left and right lower handlebar (P & Q) with two hex. screws (R-5), two flat washers (R-6) and one fixed axle (R-7) each.
2. Assemble the two pedal arms (E & F) to the main frame (J) with one hex. screw (R-12) and one washer (R-11) each.
3. Assemble the left and right covers (S-5 & S-6) to the pedal arms (E & F) with one screw (R-8) each.

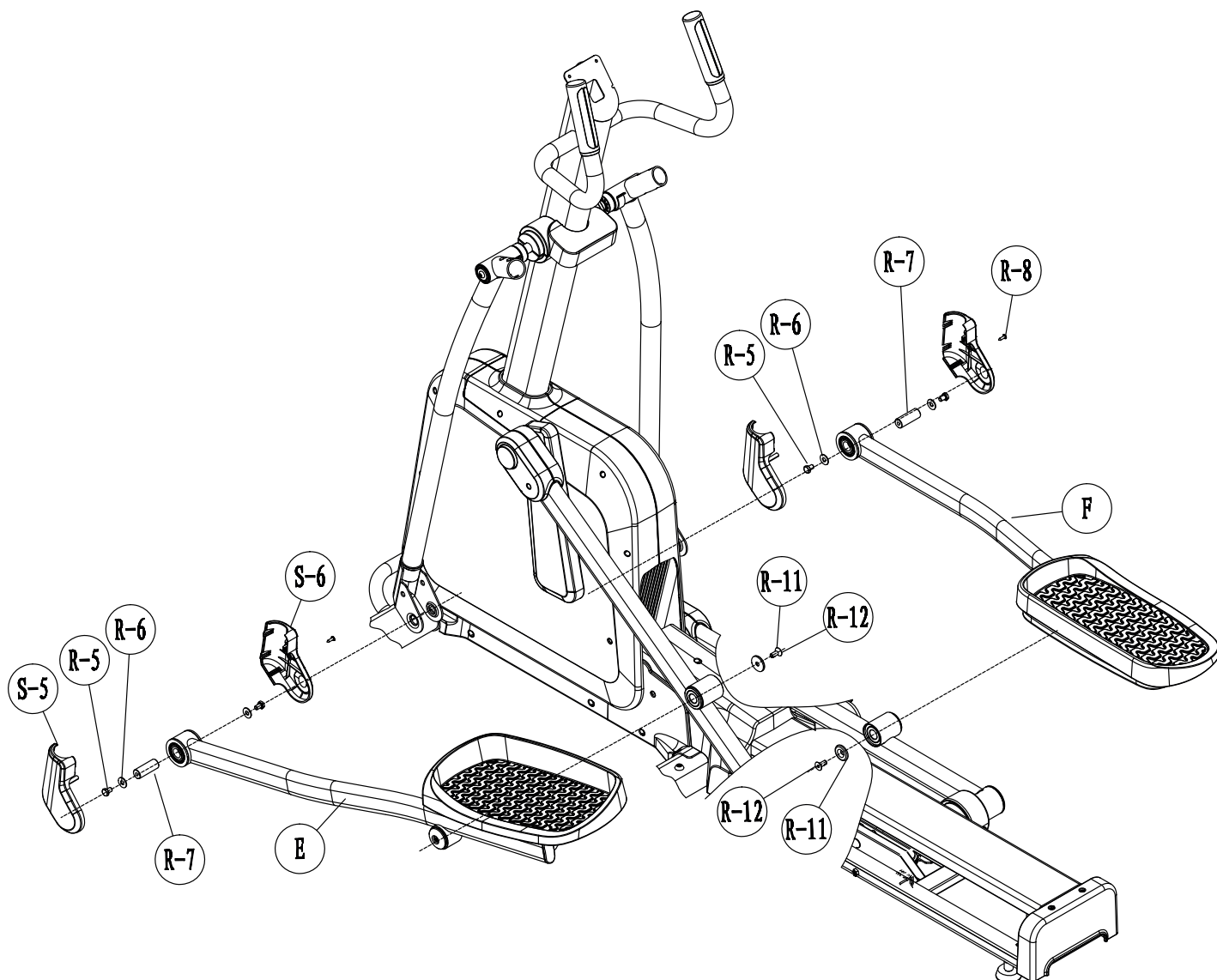

Step 7

1. Assemble the left and right upper handlebar (N & O) to the left and right lower handlebar (P & Q) with two hex. screws (R-2) and two nylon nuts (R-3).
2. Assemble the covers (S-1 & S-2, S3 & S4) to the left and right upper handlebar (N & O) with four screws (R-9).

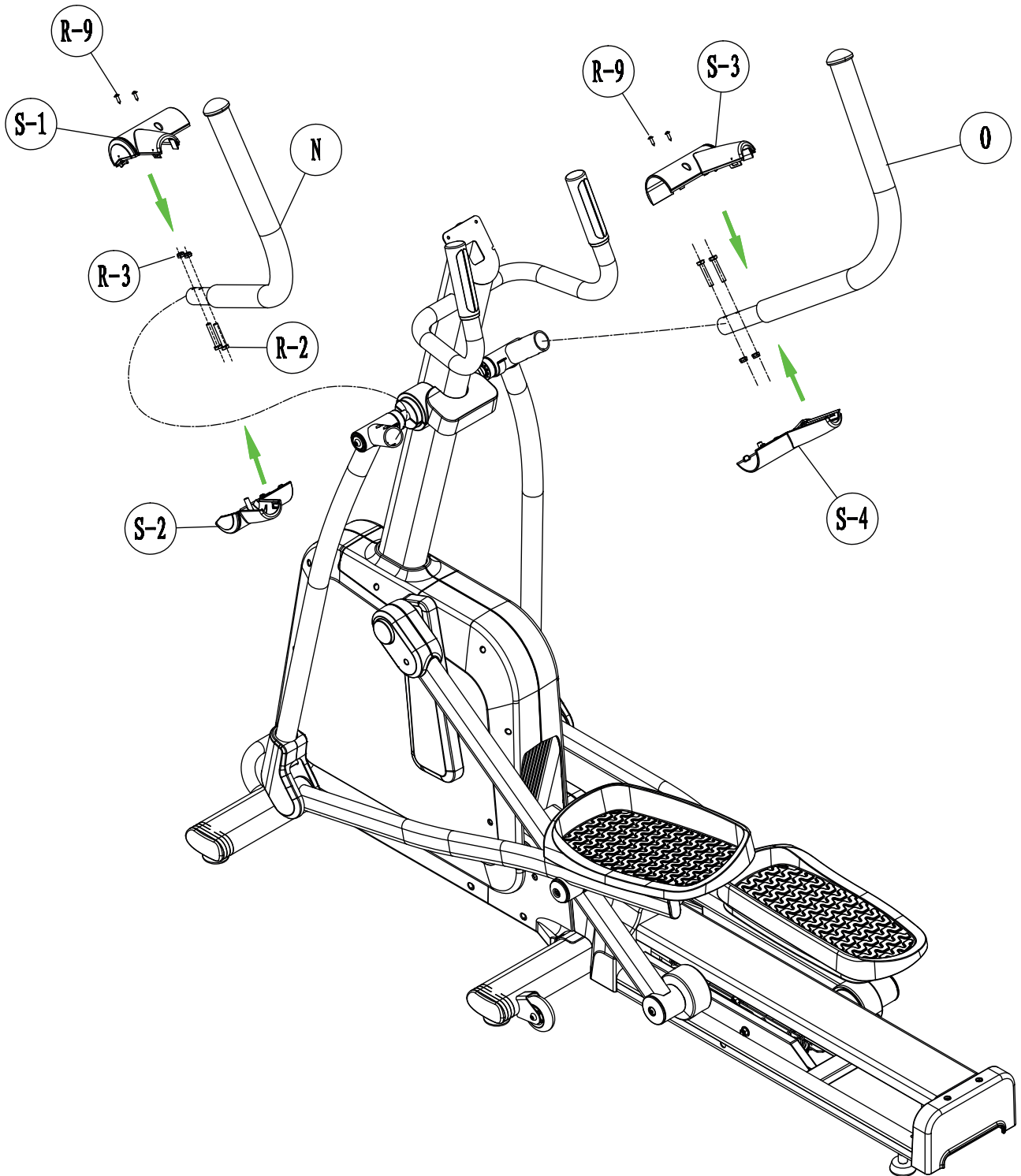

Step 8

1. Remove the four screws (A-1).
2. Connect the sensor wire (K-5) and the connecting wire (K-6) with their respective counterparts of the console (A).
3. Assemble the console to the handlebar post (L) with four screws (A-1).

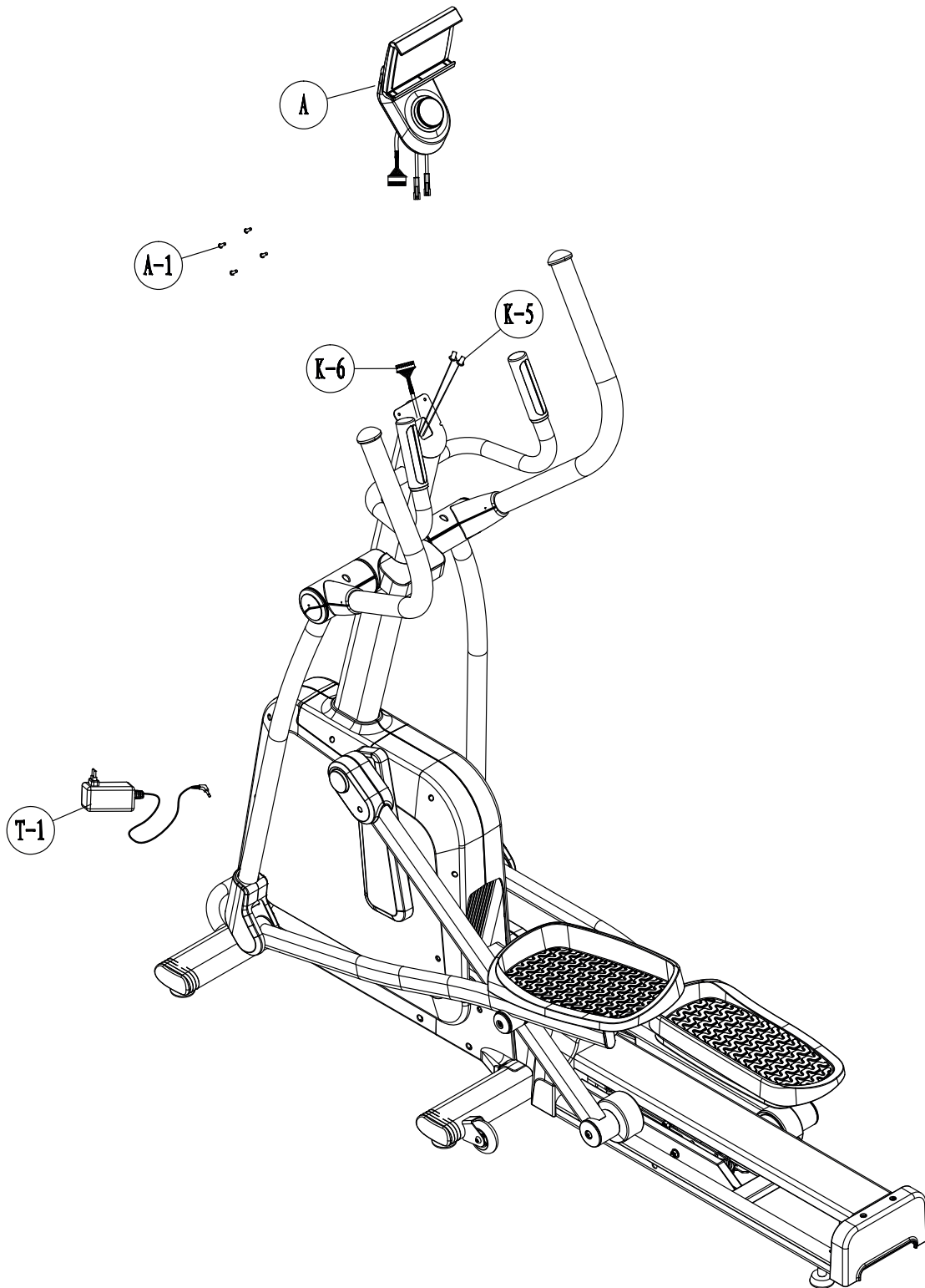

Step 9

If the floor is uneven, you can stabilize the equipment by turning the two setting screws under the main frame.

1. Lift the equipment on the desired side and rotate the setting screws under the main frame.
2. Rotate the screws clockwise in order to remove them and to raise the equipment.
3. Rotate them counterclockwise in order to lower the equipment.

Step 10

► ATTENTION

The equipment must not be connected to a multiple socket, otherwise it cannot be guaranteed that the equipment will be supplied with sufficient power. Technical errors can result.

Plug the power plug into a wall outlet that complies with the instructions in the chapter on electrical safety.

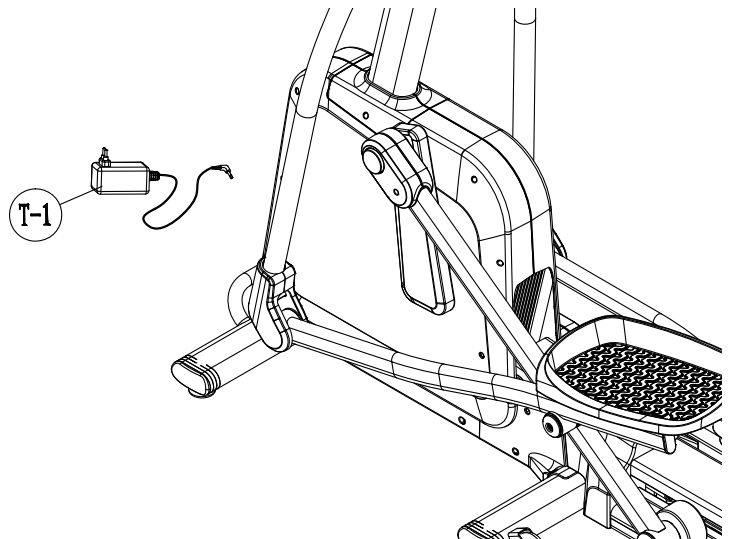

Correctly Getting On and Off

1. To get on, grip the handles with both hands and first step onto the left pedal with your left foot or onto the right pedal with your right foot and then place your foot onto the other pedal.
2. To get off, grip the handles with both hands and place one foot next to the equipment and then the other foot.

2.4 Folding Mechanism

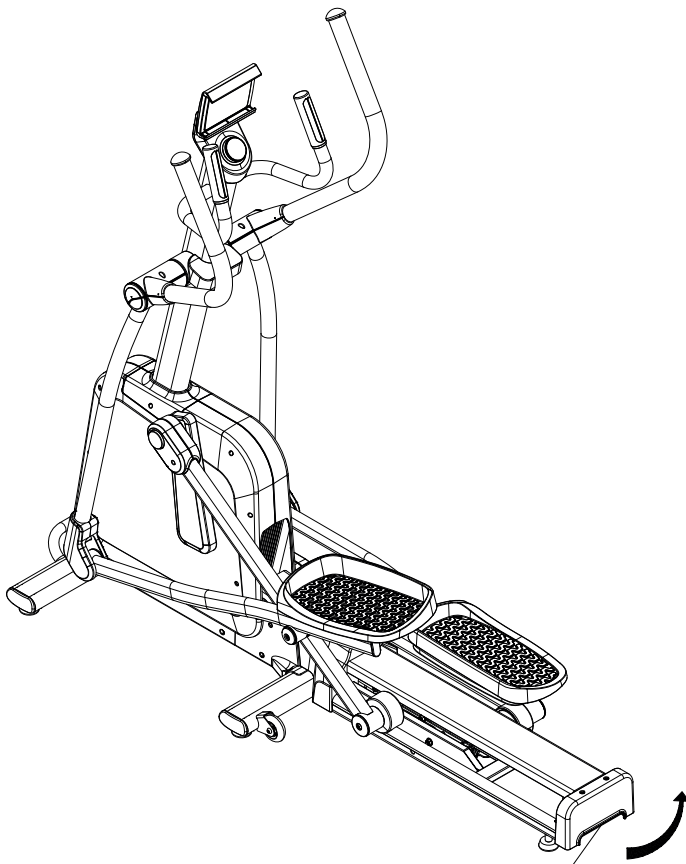

Lift until it engages audibly

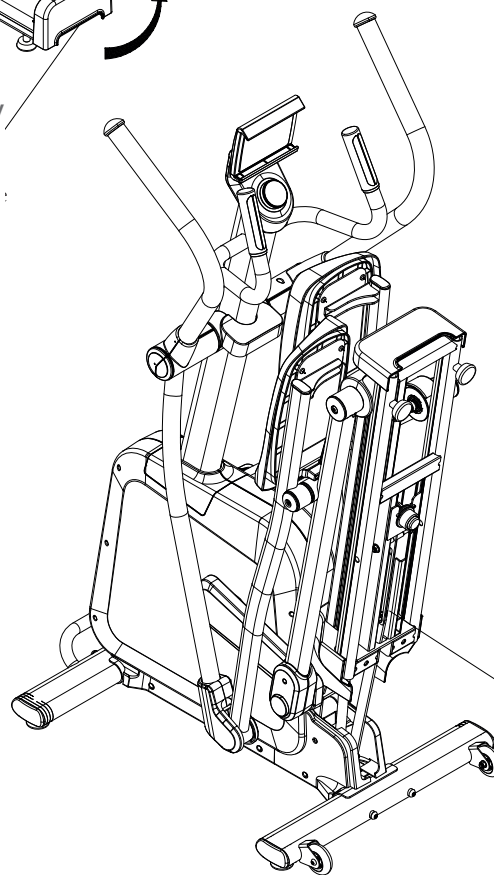

Pull the red button and release the folding mechanism. Lower it slowly to the floor.







3 OPERATING INSTRUCTIONS





① NOTICE

- + Familiarise yourself with all the functions and setting options of the device before starting training. Have the proper use of this product explained to you by a specialist.
- + Always start your training with low intensity and increase evenly and gently. End your training with a cool-down phase. If you are unsure, please consult your physician.

3.1 Console display



	SYMBOL	DISPLAY	SETTING RANGE
	TIME	00:00~99:59	00:00 ~ 99:00
	SPEED	0.0~99.9K/M	-
	DISTANCE	0 / 15~999	-
	CALORIES	0.00~99.99Km	0.0 ~99.0
	RPM	0~9999	0 ~ 9990
	LOAD	0~999	-

 	WATTS	1 ~ 16 / 1 ~ 32	1 ~ 16 / 1 ~ 32
	PULSE  WARNING Your training equipment is not a medical device. The heart rate measurement of this equipment may be inaccurate. Various factors can affect the accuracy of the heart rate measurement. The heart rate measurement serves only as a training aid.	30 ~ 230	30 ~ 230
	Wireless Technology: A signal appears above the PULSE symbol.		

3.2 Button functions

FUNCTION	DESCRIPTION
Increase (+), decrease (-) values and confirm value settings (MODE)	To increase values, turn the rotary knob clockwise (+). To reduce values, turn the rotary knob anti-clockwise (-). To confirm the value settings, press the rotary knob once.  NOTICE LED display: Active mode: Depending on intensity - green, orange or red Inactive mode: blue
Start programme (START)	To start a programme, step on the pedals
Reset values (RESET)	To reset the value settings, press and hold the rotary knob for approx. 3 seconds.

3.3 Programmes

3.3.1 Quick-Start and Manual Mode

① NOTICE

The individual parameters are shown on the display one after the other every 3 seconds. To fix a value, press the rotary knob once.

Quick-Start

To start the Quick-Start function, simply step on the pedals without any prior settings. The programme starts automatically and all values are incremented.

Manual Mode

In manual mode, you can carry out your training depending on one or more parameters. All the parameters you set are counted up during the training programme, the others are counted down accordingly. To start the programme, step on the pedals.

3.4 Wireless Connection and Fitness Apps

This console is equipped with a wireless interface. Please take note that your mobile device needs to be compatible with the wireless interface of the treadmill.

To use training apps you will have to activate the wireless connection function on your mobile device (tablet or smart phone) and start the fitness app. Select your fitness equipment. Please follow the instructions given in the app. You will find the name of your fitness equipment on a small sticker on the back of the console.

You will find the fitness apps in the app stores of Google or Apple. There you will find the apps "Kinomap" or "Zwift". Please note that these apps are produced by an external manufacturer. Fitshop does not take any responsibility regarding the availability, functionality or contents of these programmes.

IMPORTANT NOTE

The pre-installed apps are produced and provided by external manufacturers. Changes and availability within these apps might occur. Fitshop does not take any responsibility and can not be held liable for the availability, functionality or contents of these apps. To make sure the pre-installed apps are working correctly, they must be updated regularly. If needed, the respective app will notify you to do so. To update the app, you need a google account. A google email is sufficient. Just follow the instructions on the screen to perform the update.

Please note: The system is set up only for the pre-installed apps. Do not install any additional apps as their proper functionality can not be guaranteed. The installation of other apps might cause technical issues.

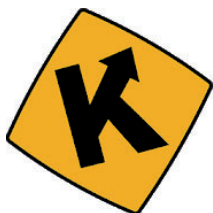
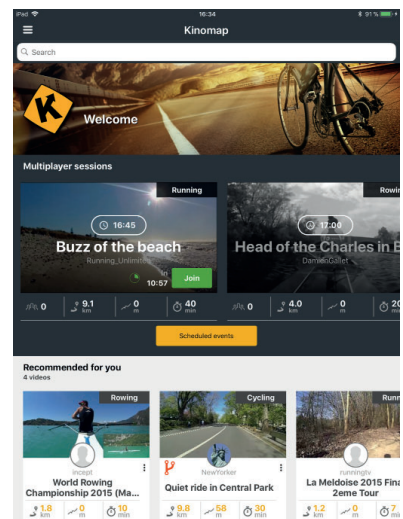
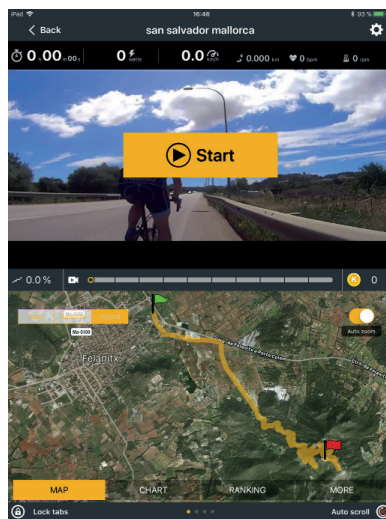
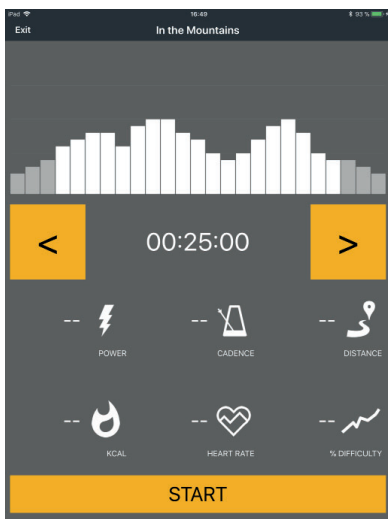

Example: Kinomap

4.1 General Instructions

WARNING

- + The storage location should be chosen so that improper use by third parties or children can be prevented.
- + If your equipment does not have transportation wheels, the equipment must be disassembled before transportation.

▶ ATTENTION

- + Make sure that the equipment is protected from moisture, dust and dirt in the selected storage location. The storage location should be dry and well ventilated and have a constant ambient temperature between 10°C and 35°C.

4.2 Transportation Wheels

▶ ATTENTION

If you want to transport your equipment over particularly sensitive and soft floor coverings, such as parquet, planks or laminate, lay out the transport route with cardboard or similar to avoid possible floor damage.

1. Stand behind the equipment and lift it until the weight is transferred to the transportation wheels. After that, you easily can move the equipment to a new position. For long transport distances the equipment should be disassembled and safely packed.
2. Select the new location by following the instructions in the section 1.4 of this manual.

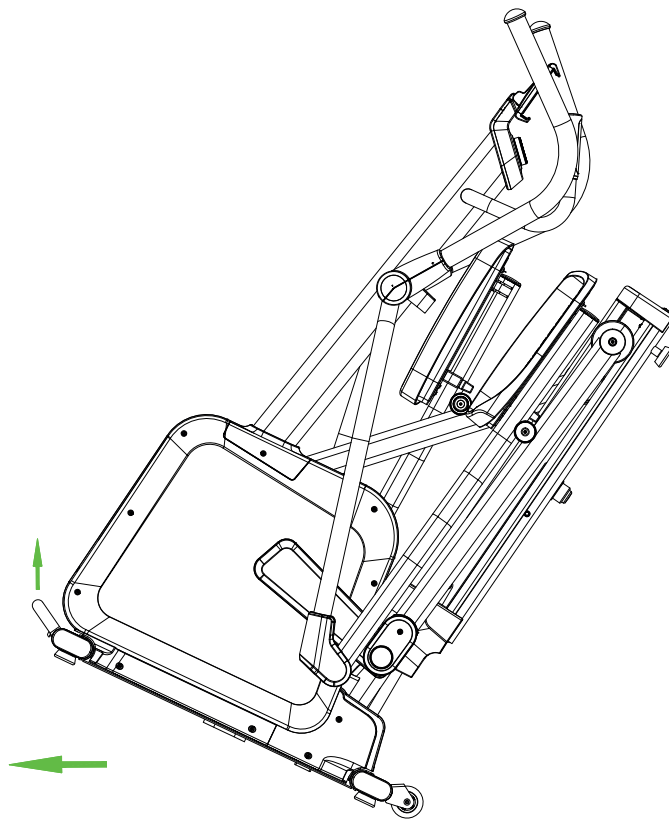

5.1 General Instructions



WARNING

- + Do not make any improper changes to the equipment.



CAUTION

- + Damaged or worn components may affect your safety and the life of the equipment. Therefore, immediately replace damaged or worn components. In such a case, contact the contract partner. The equipment must not be used until it has been repaired. If necessary, use only original spare parts.

▶ ATTENTION

- + In addition to the instructions and recommendations for maintenance and care given here, additional service and/or repair work may be necessary; this must only be carried out by authorised service technicians.

5.2 Faults and Fault Diagnosis

The equipment undergoes regular quality controls during production. Nevertheless, faults or malfunctions may occur. Frequently, individual parts are responsible for these disturbances, an exchange is usually sufficient. Please refer to the following overview for the most common errors and how to correct them. If the equipment still does not function properly, contact your contract partner.

Fault	Cause	Solution
Drive disks wobble/ make noises	Drive disk loose	Tighten nut (pay attention to left-hand / right-hand thread)
Display is blank/is not working	Loose cable connections	Check cable connections
Equipment wobbles	Equipment is not level	Align the feet
Creaking noises on the stepping area	Loose screws on stepping area	Tighten the screws on the stepping area
Creaking noises	Screw connections loosened or too tight	Check screw connections
Squeaking noises on the guide rails	Guide rails or rollers dirty or guide rails dry	Clean the guide rails and then lubricate them with a suitable lubricant

No pulse display	<ul style="list-style-type: none"> + Sources of interference in the room + unsuitable chest strap + Wrong position of chest strap + Chest strap defective or battery empty + Pulse display defective 	<ul style="list-style-type: none"> + Eliminate sources of interference (e.g. mobile phone, WLAN, lawn mower and vacuum cleaner robot, etc. ...) + Use a suitable chest strap (see RECOMMENDED ACCESSORIES). + Reposition chest strap and/or moisten electrodes + Changing batteries + Check if pulse display by hand pulse possible
------------------	---	--

5.3 Error Codes and Troubleshooting

The electronics of the equipment continuously carries out tests. In case of deviations, an error code appears on the display and normal operation is stopped for your safety.

Please contact the contract partner for technical support.

5.4 Maintenance and Inspection Calendar

To avoid damage from sweat, the equipment must be cleaned with a damp towel (no solvents!) after each training session.

The following routine tasks must be performed at the specified intervals:

Part	Weekly	Monthly	Quarterly
Display console	C	I	
Slide rails*		C	
Lubrication of slide rails and moving parts*			I
Plastic covers	C	I	
Screws and cable connections		I	
Legend: C = clean; I = inspect			

*Make sure to always clean the slide rails and moving parts before re-lubricating.

By scanning the QR-code with the camera function or QR-code scanner app of your smartphone/tablet, a video on general maintenance of a crosstrainer opens on YouTube. The video serves to illustrate the maintenance points described in this manual.

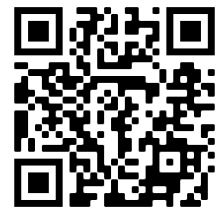

Please note that the video may not be available in your language or with appropriate subtitles.

If you cannot scan QR-codes, you can access all Fitshop videos on YouTube by first opening YouTube and entering "Fitshop" in the search field.

6 DISPOSAL

At the end of its operational life, this equipment cannot be disposed of in normal household waste. Instead, it must be disposed of via an electricals recycling centre. Further information can be obtained from your local authority's recycling service.



The materials can be recycled as per their symbols. Through the reuse, recycling of materials or other forms of recovery of old equipment, you make an important contribution to the protection of the environment.

7 RECOMMENDED ACCESSORIES

To make your training experience even more efficient and pleasant, we recommend that you add suiting accessories to your fitness equipment. For elliptical cross trainers this could for example be a **floor mat**, which makes your fitness equipment stand more securely and also protects the floor from sweat or **silicone spray** to keep moving parts in good shape.

If you have purchased a fitness machine with pulse training and want to train your heart rate, we strongly recommend that you use a compatible **chest strap**, as this ensures optimum transmission of the heart rate.

Our range of accessories offers the highest quality and makes training even better. If you would like to find out more about compatible accessories, please go to the detail page of the product in our webshop (the easiest way is to enter the article number in the search field above) and go to the recommended accessories on this page. Of course, you can also contact our customer service: by telephone, e-mail, in one of our branches or via our social media channels. We will be happy to advise you!



chest strap



floor mat



lubricant

8.1 Serial Number and Model Name

In order to provide you with the best possible service, please have the model name, article number, serial number, exploded drawing and parts list ready. The corresponding contact options can be found in chapter 10 of this operating manual.

NOTICE

The serial number of your equipment is unique. It's located on a white sticker. The exact position of this sticker is shown in the following illustration.

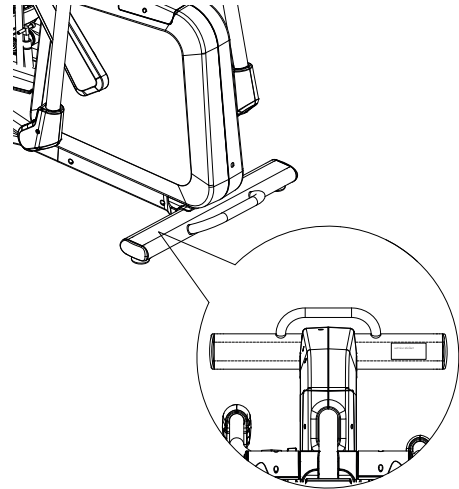

Enter the serial number in the appropriate field.

Serial number:

Brand / Category:

Model Name:

SKU:

8.2 Parts List

No.	Name	Qty.
A	CONSOLE	1
A-1	SCREW	4
B	AXLE ASSEMBLY	1
B-1	PULLEY	1
B-2	AXLE	1
B-3	HEX. SCREW	4
B-4	NYLON NUT	4
B-5	PLASTIC BUSHING	1
C	IDLER WHEEL ASSEMBLY	1
C-1	IDLER LEVER	1
C-2	IDLER WHEEL	1
C-3	BEARING	2
C-4	C RING	1
C-5	WAVE WASHER	1
D	CRANK ASSEMBLY	1
D-1	CRANK	2
D-2	CRANK COVER,INNER	2
D-3	SCREW	2
D-4	HEX. SCREW	2
D-5	NYLON NUT	2
E	PEDAL TUBE (LEFT) ASSEMBLY	1
E-1	PEDAL TUBE (LEFT)	1
E-2	BUSHING	2
E-3	BEARING	2
E-4	PEDAL (LEFT)	1
E-5	SCREW	4
E-6	SUPPORT PAD	1
E-7	SCREW	2
E-8	END CAP	1
E-9	WASHER	1
E-10	SCREW	1

F	PEDAL TUBE (RIGHT) ASSEMBLY	1
F-1	PEDAL TUBE (RIGHT)	1
F-2	BUSHING	2
F-3	BEARING	2
F-4	PEDAL (RIGHT)	1
F-5	SCREW	4
F-6	SUPPORT PAD	1
F-7	SCREW	2
F-8	END CAP	1
F-9	WASHER	1
F-10	SCREW	1
G	PEDAL ARM ASSEMBLY (LEFT)	1
G-1	PEDAL ARM (LEFT)	1
G-2	JOINT OF PEDAL ARM	1
G-3	BEARING	2
G-4	SCREW	1
G-5	FLAT WASHER	2
G-6	NYLON NUT	1
G-7	FLAT WASHER	2
G-8	BUSHING	2
G-9	BUSHING	2
G-10	CAP FOR PEDAL ARM	1
G-11	SCREW	2
G-12	ROLLER	1
G-13	BEARING	2
G-14	BUSHING	1
G-15	ROLLER COVER	1
G-16	SCREW	3
H	PEDAL ARM ASSEMBLY (RIGHT)	1
H-1	PEDAL ARM (RIGHT)	1
H-2	JOINT OF PEDAL ARM	1
H-3	BEARING	2
H-4	SCREW	1
H-5	FLAT WASHER	2

H-6	NYLON NUT	1
H-7	FLAT WASHER	2
H-8	BUSHING	2
H-9	BUSHING	2
H-10	CAP FOR PEDAL ARM	1
H-11	SCREW	2
H-12	ROLLER	1
H-13	BEARING	2
H-14	BUSHING	1
H-15	ROLLER COVER	1
H-16	SCREW	3
I	SLIDER ASSEMBLY	1
I-1	SLIDER TUBE	1
I-2	END CAP	2
I-3	COVER FOR SLIDER (LEFT)	1
I-4	COVER FOR SLIDER (RIGHT)	1
I-5	FOAM PAD	2
I-6	COVER FOR SLIDER	1
I-7	COVER FOR REAR STABILIZER	1
I-8	SCREW	9
I-9	NUT	2
I-10	LIMIT PIN	2
I-11	FOAM PAD	2
I-12	BUTTON	1
I-13	BUTTON HOLDER	1
I-14	SPRING	1
I-15	CONNECTING PIN	1
I-16	SCREW	2
I-17	ADJUSTING LEVER	1
I-18	BUSHING	2
I-19	LOCATING SHAFT	1
I-20	SUPPORT SHAFT	1
I-21	SCREW	1
I-22	PLASTIC WASHER	2

I-23	NYLON NUT	3
I-24	FLAT WASHER	3
I-25	CYLINDER	1
I-26	SCREW	1
I-27	FLAT WASHER	1
I-28	NYLON NUT	1
I-29	BUSHING	2
J	MAIN FRAME SET	1
J-1	SCREW	4
J-2	SCREW	1
J-3	SCREW	1
J-4	SCREW	1
J-5	FLAT WASHER	1
J-6	PARALLEL KEY	2
J-7	FLAT WASHER	2
J-8	SCREW	2
J-9	BUSHING	1
J-10	BUSHING	1
J-11	FLYWHEEL	1
J-12	TENSION WIRE	1
J-13	DRIVE BELT	1
J-14	BEARING	2
J-15	BUSHING	1
J-16	WAVE WAHSER	2
J-17	CHAIN COVER (LEFT)	1
J-18	CHAIN COVER (RIGHT)	1
J-19	SCREWS	7
J-20	SCREWS	14
J-21	CRANK COVER, OUTER	2
J-22	HOUSING REAR COVER	1
J-23	COVER - MAIN FRAME L	1
J-24	COVER - MAIN FRAME R	1
J-25	COVER - MAIN FRAME UPPER	1
J-26	GEAR BOX	1

J-27	CONSOLE CABLE	1
J-28	SENSOR HOLDER	1
J-29	SCREW	2
J-30	SENSOR BOX	1
J-31	SCREW	2
J-32	FLAT WASHER	4
J-33	NYLON NUT	2
J-34	BUSHING	1
J-35	BUSHING	1
J-36	BUSHING	2
J-37	BUSHING	2
J-38	ROTATING SHAFT	1
J-39	HEX. SCREW	2
J-40	FLAT WASHER	4
J-41	TUBE	2
J-42	SCREW	4
J-43	FLAT WASHER	4
J-44	NUT	2
J-45	LIMIT RING	2
J-46	LIMIT ROLLER	2
J-47	BEARING	2
J-48	SCREW	2
J-49	SCREW	2
J-50	FRONT COVER FOR PEDAL ARM (RIGHT)	2
J-51	FRONT COVER FOR PEDAL ARM (LEFT)	2
J-52	SCREW	2
J-53	JOINT PLATE FOR MAIN FRAME	1
J-54	SCREW	2
J-55	SCREW	2
K	HANDLEBAR POST ASSEMBLY	1
K-1	HANDLEBAR POST	1
K-2	HAND PULSE SENSOR	2
K-3	HAND PLUSE PLATE	4
K-4	SCREW	8

K-5	SENSOR WIRE	2
K-6	CONNECTING WIRE	1
K-7	"COVER FOR WATER BOTTLE HOLDER(UNDERNEATH)"	2
K-8	COVER FOR HANDLEBAR POST (UPPER)	1
L	FRONT STABILIZER ASSEMBLY	1
L-1	FRONT STABILIZER	1
L-2	END CAP	2
L-3	CAP	2
M	MIDDLE STABILIZER ASSEMBLY	1
M-1	MIDDLE STABILIZER	1
M-2	CAP	2
M-3	TRANSPORTATION WHEEL	2
M-4	NYLON NUT	2
M-5	SCREW	2
M-6	FLAT WASHER	2
M-7	END CAP	2
N	UPPER HANDLEBAR ASSEMBLY (LEFT)	1
N-1	UPPER HANDLEBAR, LEFT	1
N-2	FOAM GRIP	1
N-3	END CAP FOR UPPER HANDLEBAR	1
O	UPPER HANDLEBAR ASSEMBLY (RIGHT)	1
O-1	UPPER HANDLEBAR, RIGHT	1
O-2	FOAM GRIP	1
O-3	END CAP FOR UPPER HANDLEBAR	1
P	LOWER HANDLEBAR ASSEMBLY (LEFT)	1
P-1	LOWER HANDLEBAR, LEFT	1
P-2	U-SHAPED BRACKET	1
P-3	BEARING	2
P-4	FLAT WASHER	1
P-5	WAVE WAHSER	1
P-6	SCREW	1
P-7	FLAT WASHER	1
Q	LOWER HANDLEBAR ASSEMBLY (RIGHT)	1
Q-1	LOWER HANDLEBAR, RIGHT	1

Q-2	U-SHAPED BRACKET	1
Q-3	BEARING	2
Q-4	FLAT WASHER	1
Q-5	WAVE WAHSER	1
Q-6	SCREW	1
Q-7	FLAT WASHER	1
R	HARDWARE KIT	1
R-1	SCREW	4
R-2	HEX. SCREW	4
R-3	NYLON NUT	4
R-4	FLAT WASHER	2
R-5	HEX. SCREW	6
R-6	FLAT WASHER	4
R-7	FIXED AXLE OF LOWER HANDLEBAR	2
R-8	SCREW	2
R-9	SCREW	8
R-10	BUSHING	2
R-11	WASHER	2
R-12	HEX. SCREW	2
R-13	ALLEN KEY	1
R-14	BUSHING WRENCH	2
R-15	ALLEN KEY	1
R-16	ALLEN KEY	1
S	PLASTIC PARTS IN BOX	
S-1	FRONT CAP OF UPPER LEFT HANDLEBAR	1
S-2	REAR CAP OF UPPER LEFT HANDLEBAR	1
S-3	FRONT CAP OF UPPER RIGHT HANDLEBAR	1
S-4	REAR CAP OF UPPER RIGHT HANDLEBAR	1
S-5	LEFT CAP OF LOWER HANDLEBAR	2
S-6	RIGHT CAP OF LOWER HANDLEBAR	2
S-7	LEFT CAP OF HANDLEBAR POST	1
S-8	RIGHT CAP OF HANDLEBAR POST	1
S-9	COVER FOR REAR STABLIZER	1
T-1	ADAPTER	1

8.3 Exploded Drawing

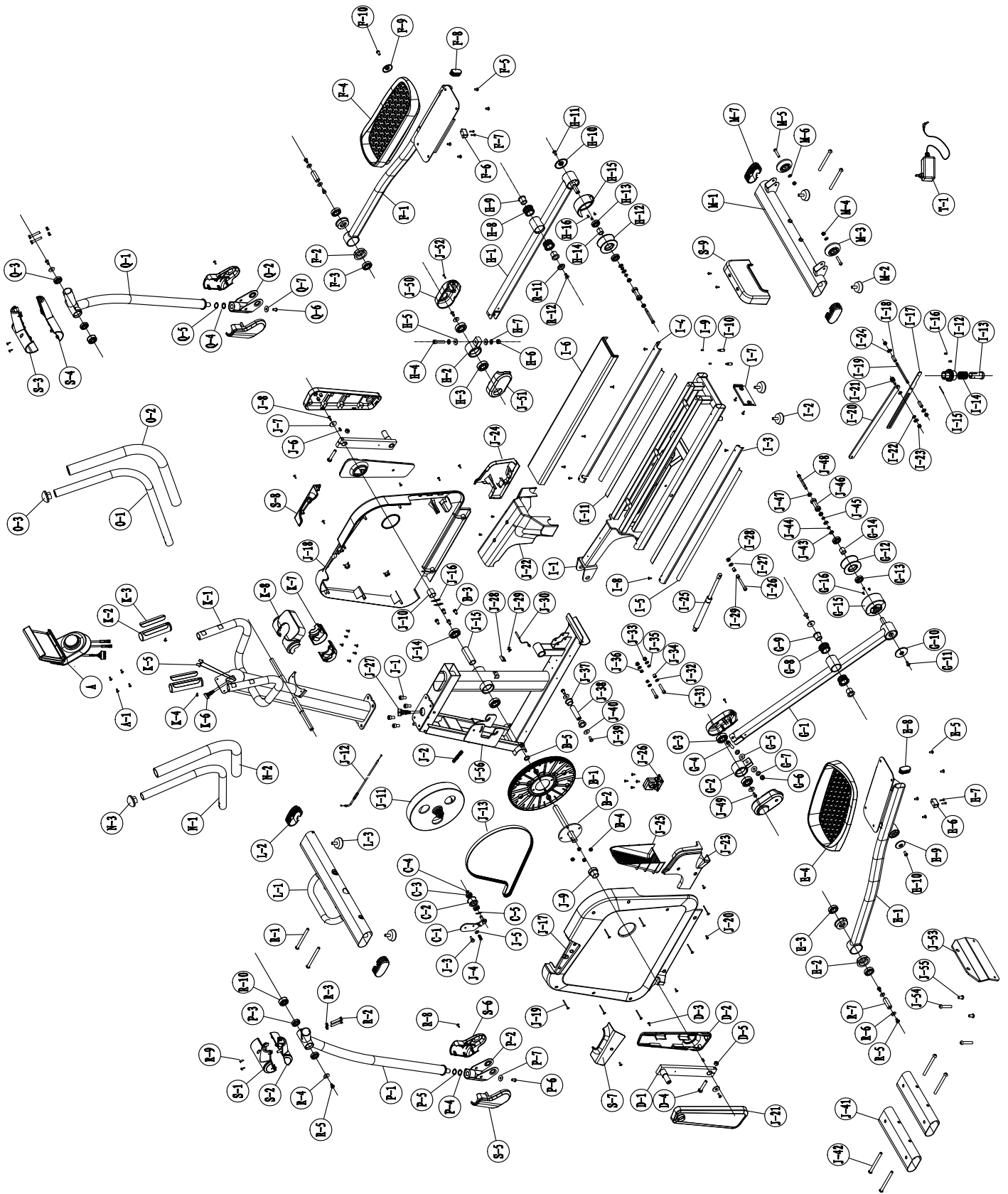

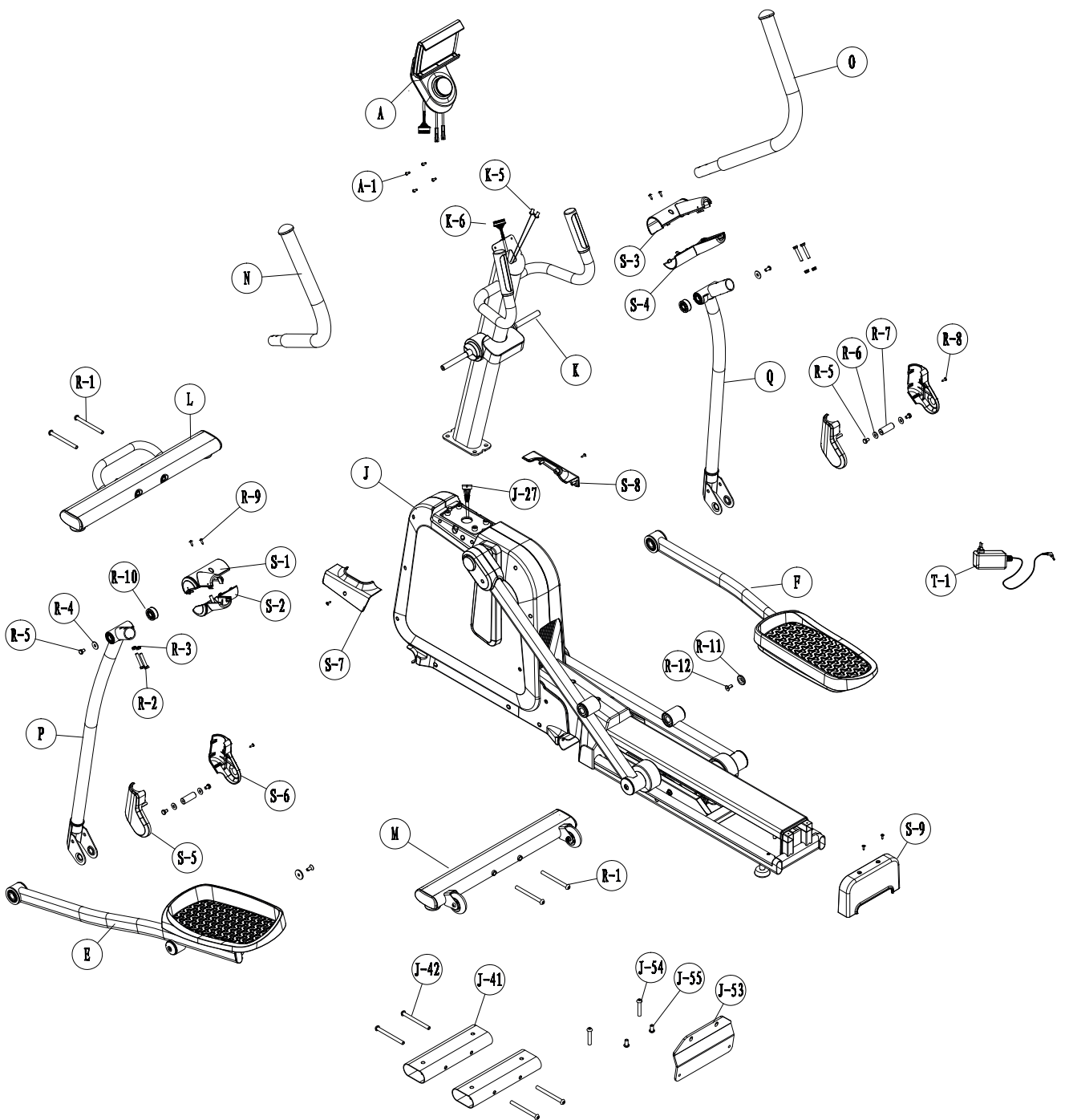

Products from cardiostrong® is subject to strict quality control. However, if a fitness equipment purchased from us does not work perfectly, we take it very seriously and ask you to contact our customer service as indicated. We are happy to help you by phone via our service hotline.

Error Descriptions

Your fitness equipment is developed for long-term, high-quality training. However, should a problem arise, please first read the operating instructions. For further assistance, please contact your contract partner or call our service hotline. To ensure your problem is solved as quickly as possible, please describe the defect as exactly as possible.

In addition to the statutory warranty, we provide a warranty for every fitness equipment purchased from us according to the following provisions.

Your statutory rights are not affected.

Warranty

The warranty is the first/original buyer.

Warranty periods

The following warranty periods begin on delivery of the fitness equipment.

Warranty period

The warranty periods, shown on our web shop, begin on delivery of the fitness equipment. The respective warranty periods for your equipment can be found on its product website.

Repair Costs

According to our choice, there will either be a repair, a replacement of individual damaged parts or a complete replacement. Spare parts, that have to be mounted while assembling the equipment, have to be replaced by the warranty holder personally and are not a part of repair. After the expiration of the warranty period, the responsibility for parts costs, repair costs, installation costs and delivery costs lies with the warranty holder.

The terms of use are defined as follows:

- + Home use: solely for private use in private households up to 3 hours per day
- + Semi-professional use: up to 6 hours per day (e. g. rehabilitation centres, hotels, clubs, company gyms)
- + Professional use: more than 6 hours per day (e. g. commercial gyms)

Warranty Service

Within the warranty period, equipment which develops faults as a result of material or manufacturing defects, will be repaired or replaced at our discretion. Ownership of equipment or parts of equipment which have been replaced is transferred to us. The warranty period is not extended nor does a new warranty period begin following repair or replacement under the warranty.

Warranty Conditions

For the warranty to be valid, the following steps must be taken:

Please contact our customer service by email or phone. If the product under warranty has to be sent in for repair, the seller bears costs. After expiry of the warranty, the buyer bears the costs of transport and insurance. If the fault is covered by our warranty, you will receive a new or repaired equipment in return.

Warranty claims are invalid in case of damage resulting from:

- + misuse or improper handling
- + environmental influences (moisture, heat, electrical surge, dust, etc.)
- + failure to follow the current safety measures for the equipment
- + failure to follow the operating instructions
- + use of force (e. g. hitting, kicking, falling)
- + interventions which were not carried out by one of our authorized service centres
- + unauthorised repair attempts

Proof of Purchase and Serial Number

Please make sure that you are able to provide the appropriate receipt when claiming on your warranty. So that we can clearly identify the model of your equipment, and for the purposes of our quality control, you will need to give the serial number of your equipment, when contacting the service team. Where possible please have your serial number and your customer number ready when you call our service hotline. It will help us to deal with your request swiftly.

If you cannot find the serial number on your fitness equipment, our service team is at your disposal to offer further information.

Service outside of the Warranty Period

We are also happy to issue an individual cost estimate if there is a problem with your fitness equipment after the warranty has expired, or in cases which do not fall under the terms of the warranty, e. g. normal wear and tear. Please contact our customer service team to find a quick and cost-effective solution to your problem. In such a case you will be responsible for the delivery costs.

Communication

Many problems can be solved just by speaking to us as your specialist supplier. We know how important it is to you as a user of the fitness equipment to have problems solved quickly and simply, so you can enjoy working out with minimal interruption. For that reason, we also want to resolve your queries quickly and in a straightforward manner. Thus, please always keep your customer number and the serial number of the faulty equipment handy.

10 CONTACT

DE	DK	UK
<p>TECHNIK</p> <p>☎ +49 4621 4210-900 ☎ +49 4621 4210-698 ✉ technik@fitshop.de 🕒 Öffnungszeiten entnehmen Sie unserer Homepage.</p> <p>SERVICE</p> <p>☎ 0800 20 20277 (kostenlos) ☎ 04621 4210 - 0 ✉ info@fitshop.de 🕒 Öffnungszeiten entnehmen Sie unserer Homepage: https://stg.fit/statita</p>	<p>TEKNIK OG SERVICE</p> <p>☎ 80 90 16 50 +49 4621 4210-945 ✉ info@fitshop.dk 🕒 Åbningstider kan findes på hjemmesiden: https://stg.fit/statit7</p>	<p>CUSTOMER CARE</p> <p>☎ +44 141 737 2249 or +44 141 876 3972 ✉ customercare@fitshop.co.uk 🕒 You can find the opening hours on our homepage: https://stg.fit/statitd</p>
	FR	BE
	<p>TECHNIQUE & SERVICE</p> <p>☎ +33 (0) 189 530984 +49 4621 42 10 933 ✉ info@fitshop.fr 🕒 Vous trouverez les heures d'ouverture sur notre site Internet: https://stg.fit/statit4</p>	<p>TECHNIQUE & SERVICE</p> <p>☎ 02 732 46 77 +49 4621 4210 933 ✉ info@fitshop.be 🕒 Vous trouverez les heures d'ouverture sur notre site Internet: https://stg.fit/statit8</p>
ES	NL	INT
<p>TECNOLOGÍA Y SERVICIOS</p> <p>☎ 911 238 029 ✉ info@fitshop.es 🕒 Consulta nuestro horario de apertura en la página web: https://stg.fit/statit5</p>	<p>TECHNISCHE DIENST & SERVICE</p> <p>☎ +31 172 619961 ✉ service@fitshop.nl 🕒 De openingstijden vindt u op onze homepage: https://stg.fit/statit3</p>	<p>TECHNICAL SUPPORT & SERVICE</p> <p>☎ +49 4621 4210-944 ✉ service-int@fitshop.de 🕒 You can find the opening hours on our homepage: https://stg.fit/statita</p>
PL	AT	CH
<p>DZIAŁ TECHNICZNY I SERWIS</p> <p>☎ 22 307 43 21 +49 4621 42 10-948 ✉ info@fitshop.pl 🕒 Godziny otwarcia można znaleźć na stronie głównej: https://stg.fit/statit6</p>	<p>TECHNIK & SERVICE</p> <p>☎ 0800 20 20277 (Freecall) +49 4621 42 10-0 ✉ info@fitshop.at 🕒 Öffnungszeiten entnehmen Sie unserer Homepage: https://stg.fit/statitb</p>	<p>TECHNIK & SERVICE</p> <p>☎ 0800 202 027 +49 4621 42 10-0 ✉ info@fitshop.ch 🕒 Öffnungszeiten entnehmen Sie unserer Homepage: https://stg.fit/statit9</p>

Please find a detailed overview including address and opening hours for all stores of Fitshop UK on the following website:

www.fitshop.co.uk/storelocator

WE LIVE FITNESS

WEBSHOP AND SOCIAL MEDIA

The Fitshop Group is Europe's largest specialist for home fitness equipment with currently 70 stores and one of the world's most renowned online mail order companies for fitness equipment.

Fitshop UK is part of the Fitshop Group. Private customers order via the 25 web shops in the respective national language or have their desired equipment assembled on site. In addition, the company supplies fitness studios, hotels, sports clubs, companies and physio practices with professional equipment for endurance and strength training.

The Fitshop group offers a wide range of fitness equipment from renowned manufacturers, high-quality in-house developments and comprehensive services, such as a build-up service and sports scientific advice before and after the purchase. The company employs numerous sports scientists, fitness trainers and competitive athletes.

Visit us also on our social media platforms or our blog!



<https://www.fitshop.co.uk>
www.fitshop.co.uk/blog



www.facebook.com/fitshop.co.uk



www.instagram.com/fitshop_uk



www.youtube.com/@fitshop_uk

TAURUS

 cardiostrong

BODYCRAFT

BodyMax

Notes

Notes

