

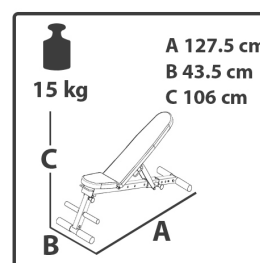

Assembly and operating instructions

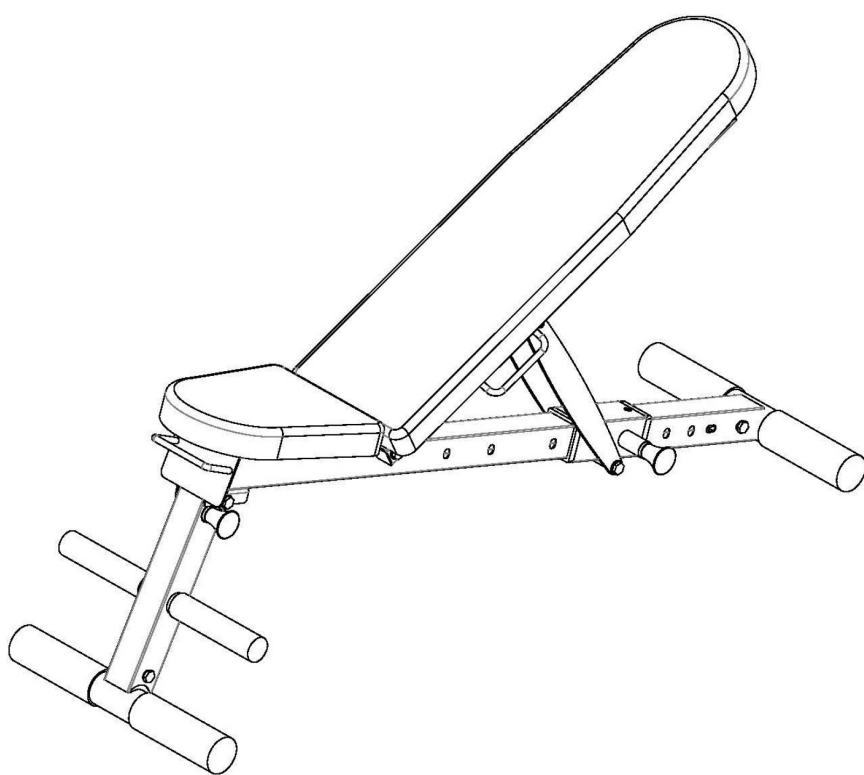

SEBR2586.01.01

Item number SEBR2586

BodyMax CF420 Folding Incline Bench



Dear Customer,

Thank you for deciding for a high-quality training equipment of the brand BodyMax, the brand that makes athlete's hearts beat faster. BodyMax offers a wide range of home fitness equipment like elliptical cross trainers, ergometers, treadmills and rowing machines. BodyMax equipment is the optimal equipment for all those who want to train at home independent of goals and fitness level. For further information please visit www.powerhouse-fitness.co.uk or www.bodymax-fitness.com.



SAFETY NOTICE

Please read all of the instructions carefully before assembly and first use. These instructions are intended to ensure speedy assembly and explain safe usage. Make sure that all people exercising with the equipment (in particular children and persons with limited physical, sensory, mental or motor capabilities) are informed about these instructions and its content in advance. In case of doubt, a responsible person must supervise the use of the equipment.

This equipment has been manufactured according to the latest safety knowledge. As far as possible, potential safety hazards which could cause injury have been eliminated. Make sure to follow the instructions carefully and that all parts are securely in place. If required, read through the instructions again to correct any mistakes.

Please pay close attention to the safety and maintenance instructions given here. The contract partner cannot be held liable for damage to health, accidents or damage to the equipment when it is not used in accordance with these instructions.

The equipment is only suitable for use at home. The equipment is not suitable for semi-professional (e. g., hospitals, clubs, hotels, schools, etc.) and commercial or professional use (e. g., health clubs).

Retain these instructions in a safe place for future reference, maintenance or when ordering replacement parts.

CONTENTS

1	GENERAL INFORMATION	6
1.1	Technical data	6
1.2	Personal safety	6
1.3	Set-up place	7
2	ASSEMBLY INSTRUCTIONS, MAINTENANCE AND CARE	8
2.1	General instructions	8
2.2	Faults and Troubleshooting	9
2.3	Maintenance and service calendar	9
3	ASSEMBLY	10
3.1	Package contents	10
3.2	Assembly instructions	12
4	OPERATING INSTRUCTIONS	14
4.1	Stretching exercises for leg & chest muscles	14
4.2	Workout journal	16
5	WARRANTY INFORMATION	17
6	DISPOSAL	19
7	ORDERING SPARE PARTS	20
7.1	Service-hotline	20
7.2	Serial number and model name	20
7.3	Parts list	21
7.4	Exploded drawing	22

1.1 Technical data

Article weight (gross, including packaging): 16.7 kg

Article weight (net, without packaging): 15.2 kg

Packaging dimensions (L x W x H): approximately 119 cm x 28 cm x 16.5 cm

Set-up dimensions (L x W x H): approximately 127.5 cm x 43.5 cm x 106 cm

Maximum user weight: 150 kg / 330 lbs

1.2 Personal safety

- + Before you start using the equipment, you should consult your physician that this type of exercise is suitable for you from a health perspective. Particularly affected are persons who: have a hereditary disposition to high blood pressure or heart disease, are over the age of 45, smoke, have high cholesterol values, are overweight and/or have not exercised regularly in the past year.
- + Please note that working out excessively can seriously damage your health. Please also be aware that heart rate monitoring systems might be imprecise.
- + The equipment may only be used for its intended purpose; that means for indoor cycle workouts for adults.
- + Any other usage is prohibited and potentially dangerous. The contract partner cannot be held liable for damage resulting from improper use.
- + The equipment is strictly for use by one person at a time.
- + Children should not be allowed unsupervised access to the equipment.
- + Before starting your training, make yourself familiar with all of the equipment's functions and setting options. Have an expert explain the correct usage of the product to you.
- + The machine is NOT equipped with a free-run system. This means: If you move the flywheel, the pedals move as well. In order to avoid knee injuries, do not try to stop the equipment by pedaling backwards. Also do not try to take your feet from the rotating pedals. The motion can only be stopped by pressing the emergency brake or through a controlled reduction of the pedal rate.
- + Only use this indoor cycle with high pedal rotations or while standing after you have practiced with lower pedal rotations.

- + Never bring your hands or other objects near moving parts.
- + During use, wear suitable sports clothing rather than loose or baggy clothing. When selecting sports shoes, think about the suitability of the sole – preferably this should be made of rubber or other non-slip materials. Shoes with heels, leather soles, studs or spikes are not suitable. Never work out in bare feet.
- + It is also important to take note of the information given in the workout instructions for creating a workout plan.
- + At the first signs of weakness, nausea, dizziness, pain, difficulty in breathing or other abnormal symptoms, stop your workout immediately and, if necessary, consult your physician.

1.3 Set-up place

- + The equipment should only be used indoors, in a sufficiently heated and dry area (ambient temperature between 10°C and 35°C). The equipment should not be used outdoors or in rooms with high humidity (over 70%) like swimming pools. The equipment should only be stored in surroundings with an ambient temperature between 5°C and 45°C.
- + The training room should be well ventilated during training and not be exposed to any draughts.
- + Choose a location in which to place the equipment such that there is enough free space/clearance to the front, the rear and to the sides of the equipment (at least 1.50 m). Furthermore, the equipment should not be set up in main entrances or on escape routes.
- + No objects of any type should be inserted into the openings of the equipment.
- + The equipment should be placed on a level and solid surface, any unevenness in the floor should be leveled out.
- + A floor protective mat / equipment underlay can help to protect high-quality floor coverings (parquet, laminate, cork, carpets) from dents and sweat and can help to level out slight unevenness.

2.1 General instructions

- + Please check if all parts and tools belonging to the equipment are included in the delivery and if there is any transport damage. If there are any complaints, please contact your contract partner directly.
- + Some of the nuts and bolts to be used in assembly are already pre-mounted in order to make set-up as easy as possible.
- + The equipment must be assembled by adults. In case of doubt, ask for assistance from another person with technical skills.
- + Keep children away from the equipment during assembly, because small parts are included in the delivery and may be swallowed.
- + Make sure that you have enough space (at least 1.50 m) in every direction during assembly.
- + Do not leave any tools and packaging materials like plastic sheeting laying around to avoid danger of suffocation for children.
- + Assemble the equipment on an underlay mat or on the cardboard packaging in order to avoid damage to the equipment and to the floor (scratches).
- + Before starting assembly, all individual parts should be placed on the floor next to each other.
- + Read the assembly instructions carefully and assemble the equipment according to the illustrations. Proceed carefully and cautiously.
- + First loosen all parts and check for their correct fitting. Then tighten the screws using a tool.
- + Modifications to the design or improper repairs may pose a hazard to the user and should not be carried out. The product warranty may be void as a result.
- + Only authorized service technicians are permitted to carry out all servicing and/or repairs – it excludes maintenance and care.
- + Damaged or worn components may impair your safety and the lifespan of the equipment. You should therefore immediately replace damaged or worn components. Please contact your contract partner in such a case. The equipment should no longer be used until it has been repaired. When needed, only use original BodyMax spare parts.
- + Check the tightness of all screw connections once a month.
- + In order to be able to guarantee the constructively defined safety level of this equipment, we recommend having the equipment regularly maintained (at least once a year) by specialists (service technicians of your contract partner).

- + The equipment may be cleaned of dust, dirt and sweat using a damp cloth. The use of solvents should be strictly avoided. Also, make sure that no liquids (e. g. sweat) get into the openings of the equipment (e. g. console).

2.2 Faults and Troubleshooting

The equipment runs through regular quality controls during production. Nevertheless, errors or malfunctions on the equipment may occur. Individual parts are often the cause of faults and replacement is usually sufficient. Please use the following overview to see the six most common errors and how to repair them. If the equipment still does not work properly, please contact your contract partner.

Problem	Cause	Solution
Squeaking & cracking noises	Loose or too tight screw connection	Check or lubricate screw connection

2.3 Maintenance and service calendar

The indoor cycle must be cleaned after every training session with a moist towel (no solvent!) in order to avoid damage caused by sweat.

The following routine work must be executed in the specified time intervals:





Part	Weekly	Monthly	Annually
Check screws		I	

3 ASSEMBLY



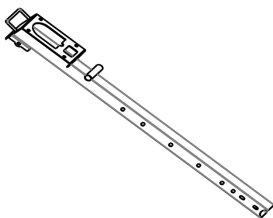
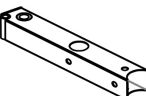
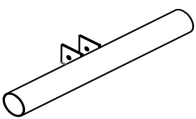
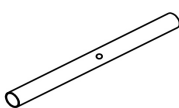

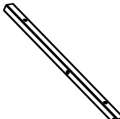

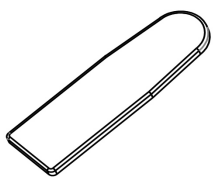
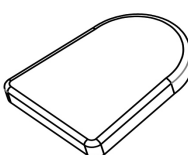



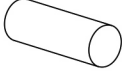

In order to make the assembly of the equipment easier, we recommend that you do not initially fully tighten the screws and bolts. However, you should make sure that all screws and bolts are firmly tightened after assembly.

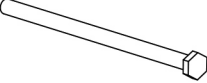
3.1 Package contents

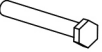
The package contains the parts represented in the illustration. If one of the illustrated parts is missing, please contact your contract partner.

 01# Main Frame 1pc	 02# Support Frame 1pc	 03# Base Frame 2pcs
 04# Foot Tube 1pc	 05# Carriage 1pc	 06# Right Backrest Frame 1pc
 07# Left Backrest Frame 1pc	 08# Backrest Support 1pc	 09# Backrest Cushion 1pc
 10# Seat Cushion 1pc		

Screws

 11L# Long Knob 1pc	 11S# Short Knob 1pc	 12# Small Cover 2pcs	 13# Big Cover 4pcs
 14# Carriage Sleeve 2pcs	 15# Backrest Frame Cap 4pcs	 16# M10*180mm Hex Bolt 2pcs	 17# M10*100mm Hex Bolt 1pc
 18# M10*75mm Hex Bolt 1pc	 19# M8*20mm Hex Bolt 11pcs	 20# M8*50mm Hex Bolt 4pcs	 21# M10 Washer 8pcs
 22# M8 Washer 15pcs	 23# M10 Locknut 4pcs	 24# Bushing 2pcs	

3.2 Assembly instructions

Step 1:

Unpack the carton and place all parts on the floor carefully and remove the packing material and check each part as manual.

1. Slide the Carriage (5) onto the Main Frame(1) using the Short Knob (11S).
2. Attach the Base Frame (3) to Support Frame(2) using 3pcs M8*20mm Hex Bolt (19) and 3pcs M8 washer (22).
3. Attach the Foot Tube (4) into Support Frame(2) using 1pc M8*20mm Hex Bolt (19) and 1pc M8 washer (22).
4. Slide the Small Cover (12) onto the Foot Tube (4).

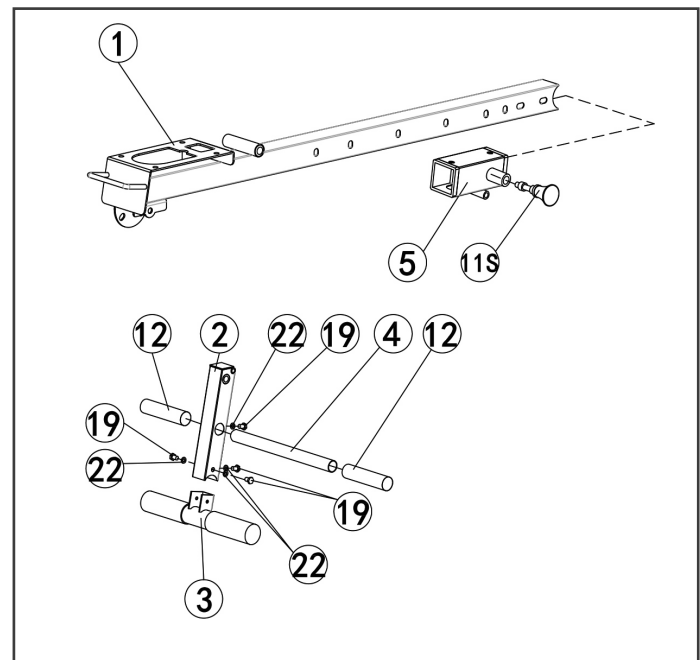

Step 2:

1. Attach another Base Frame (3) to the Main Frame (1) using 3pcs M8*20mm Hex Bolt (19) and 3pcs M8 washer (22).
2. Attach the Support Frame (2) to the Main Frame (1) using 1pc M10*75mm Hex Bolt (18) and 1pcs M10 washer (21) and 1pc M10 Locknut (23), Long Knob(11L).

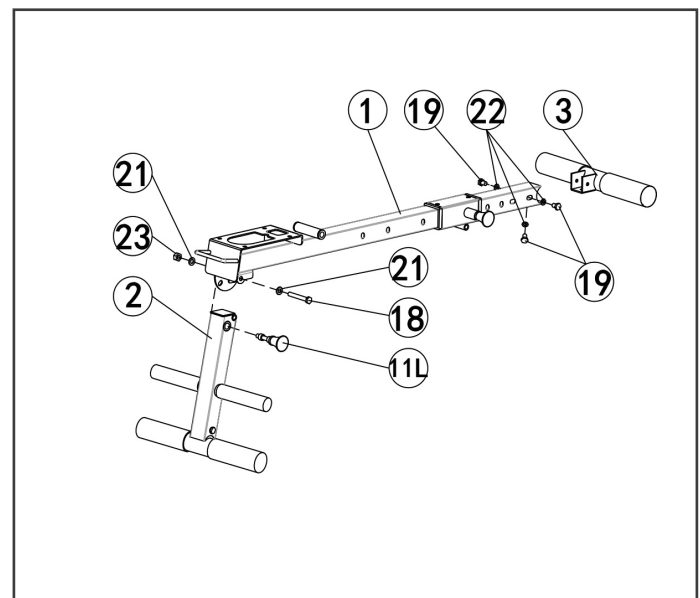

Step 3:

Note: 2pcs Bushing (24) have been assembled onto the Main Frame(1).

1. Attach the Right Backrest Frame (6) and the Left Backrest Frame (7) to the Main Frame (1) using 1pc M10*180mm Hex Bolt (16) and 2pcs M10 washer (21) and 1 pc M10 Locknut(23).

2. Attach the Backrest Support (8) to the Right Backrest Frame (6) and the Left Backrest Frame (7) using 1pc M10*180mm Hex Bolt (16) and 2pcs M10 washer (21) and 1 pc M10 Locknut(23).

3. Attach the Backrest Support (8) to the Carriage (05) using 1pc M10*100mm Hex Bolt (17) and 2pcs M10 washer (21) and 1 pc M10 Locknut(23).

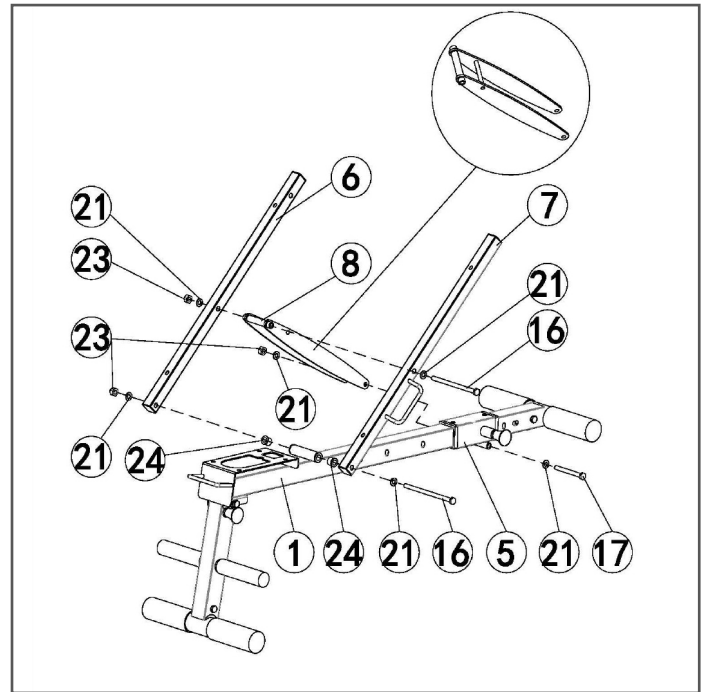

Step 4:

1. Attach the Seat Cushion (10) to the Main Frame (1) using 4pcs M8*20mm Hex Bolt (19) and 4pcs M8 washer (22).

2. Attach the Backrest Cushion (9) to Right Backrest Frame (6) and the Left Backrest Frame (7) using 4pcs M8*50mm Hex Bolt (20) and 4pcs M8 washer (22).

Now go back and recheck all bolts and nuts are tightened, before using machine.

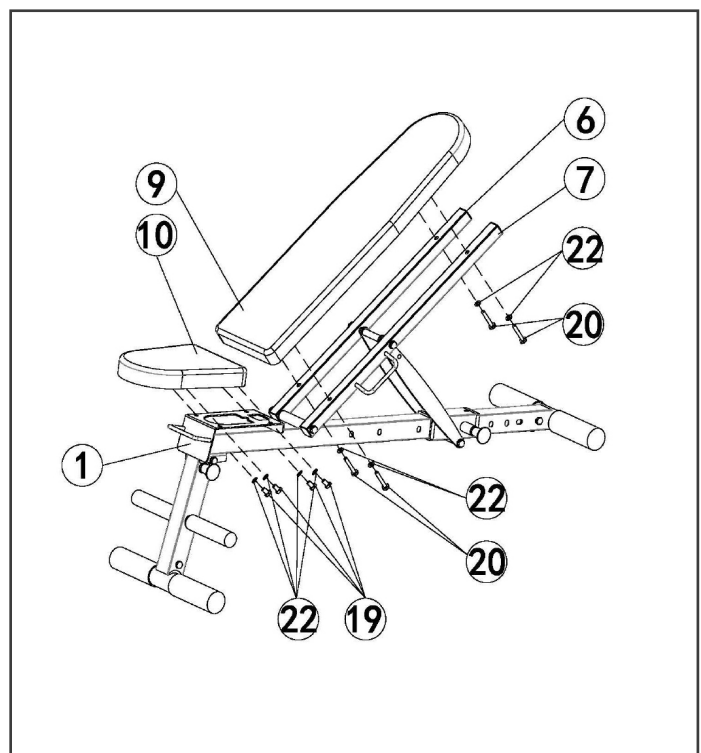

4.1 Stretching exercises for leg and chest muscles

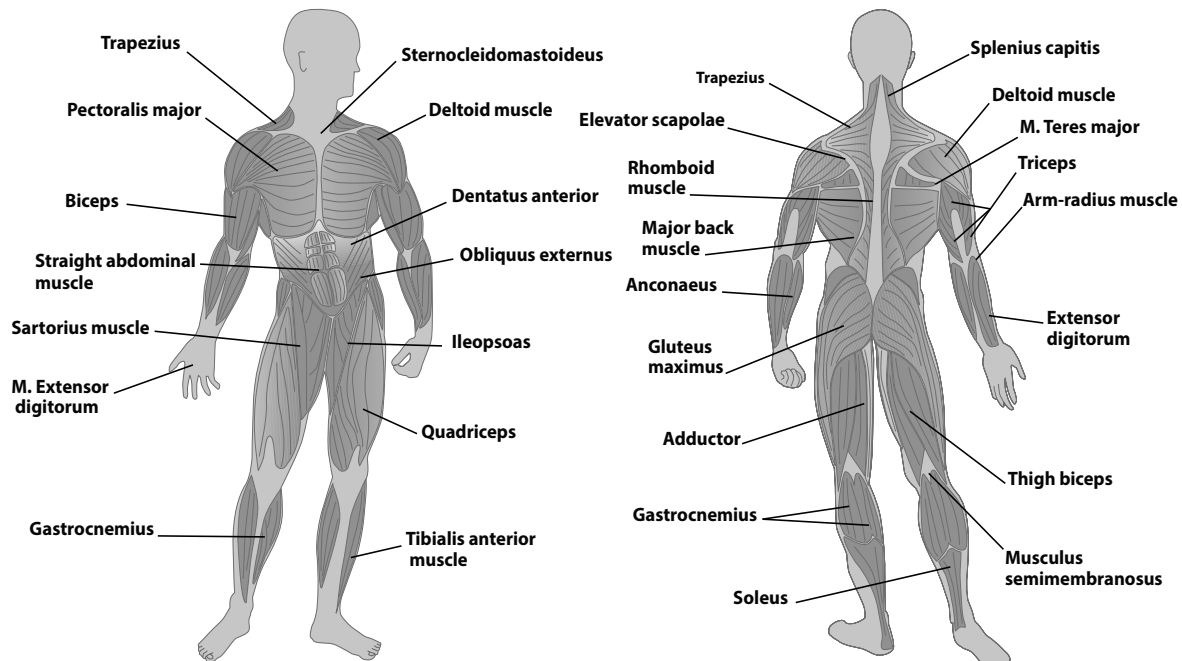

1. Exercise: Stretching of front thigh / leg extension (quadriceps)

- Stable position, grab arches of feet
- Pull heel towards buttocks, knee points downwards (no abduction)
- Straight upper body, avoid tilting the pelvic forward (hollow back) by tensing the abdominal muscles
- Change legs

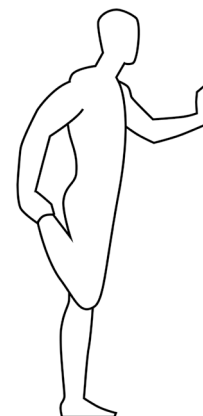

2. Exercise: Stretching the back thigh / leg curl (hamstring)

- Pull thigh towards upper body with both hands
- Stretch through increased stretching in the knee joint
- The lower leg maintains contact with the floor, keep hips bent
- Change legs

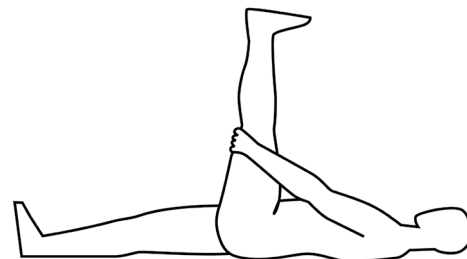

3. Exercise: Stretching the calf muscles (gastrocnemius)

- Place feet parallel to each other pointing forward, the heels touch the floor
- Support yourself on a chair coming from a lunge
- Move your body weight to the front leg, press your heel from the rear leg towards the floor and hold the contact
- Slowly stretch your knee of the rear leg until you feel the stretch in your calves
- Change legs

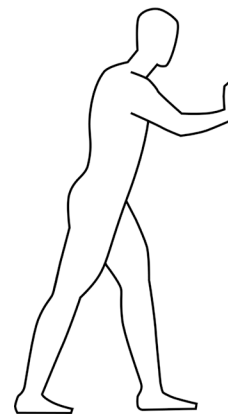

4. Exercise: Stretching the chest muscles (pectoralis major)

- Stand parallel to a wall
- Place your forearm at 90° to the wall with the elbow just above shoulder height
- Turn your head and upper body gradually to the opposite sides until you feel a stretch in the front chest, of the shoulder being leaned on
- Pay attention to tension in your abdominal and gluteal muscles
- Your weight is on your front leg
- Change legs

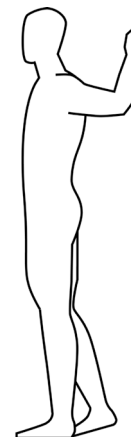

All recommendations of these instructions apply solely to healthy persons and are not suitable for those with heart or cardiovascular problems. All of the tips are intended only as a guide to help you create a workout. Your physician can offer appropriate advice for particular, personal requirements.

We hope you enjoy your workout and have a lot of success!

5 WARRANTY INFORMATION

BodyMax training fitness equipment is subject to strict quality controls. However, if a fitness equipment purchased from us does not work perfectly, we take it very seriously and ask you to contact our customer service as indicated. We are happy to help you by phone via our service hotline.

Error descriptions

Your fitness equipment is developed for long-term, high-quality training. However, should a problem arise, please first read the operating instructions. For further assistance, please contact your contract partner or call our service hotline. To ensure your problem is solved as quickly as possible, please describe the defect as exactly as possible.

In addition to the statutory warranty, we provide a warranty for every fitness equipment purchased from us according to the following provisions.

Your statutory rights are not affected.

Warranty

The warrantee is the first/original buyer and/or any person who received a newly purchased product as a gift from the original buyer.

Warranty periods

The following warranty periods begin on delivery of the fitness equipment.

Model	Use	Full warranty
CF420 Folding Incline Bench	Home use	24 months

Repair costs

According to our choice, there will either be a repair, a replacement of individual damaged parts or a complete replacement. Spare parts, that have to be mounted while assembling the equipment, have to be replaced by the warrantee personally and are not a part of repair. After the expiration of the warranty period for repair costs, a pure parts warranty applies, which does not include the repair, installation and delivery costs.

The terms of use are defined as follows:

- Home use: solely for private use in private households up to 3 hours per day
- Semi-professional use: up to 6 hours per day (e. g. rehabilitation centers, hotels, clubs, company gyms)
- Professional use: more than 6 hours per day (e. g. commercial gyms)

Warranty service

Within the warranty period, equipment which develops faults as a result of material or manufacturing defects, will be repaired or replaced at our discretion. Ownership of equipment or parts of equipment which have been replaced is transferred to us. The warranty period is not extended nor does a new warranty period begin following repair or replacement under the warranty.

Warranty conditions

For the warranty to be valid, the following steps must be taken:

Please contact our customer service by email or phone. If the product under warranty has to be sent in for repair, the seller bears costs. After expiry of the warranty, the buyer bears the costs of transport and insurance. If the fault is covered by our warranty, you will receive a new or repaired equipment in return.

Warranty claims are invalid in case of damage resulting from:

- misuse or improper handling
- environmental influences (moisture, heat, electrical surge, dust, etc.)
- failure to follow the current safety measures for the equipment
- failure to follow the operating instructions
- use of force (e. g. hitting, kicking, falling)
- interventions which were not carried out by one of our authorized service centers
- unauthorized repair attempts

Proof of purchase and serial number

Please make sure that you are able to provide the appropriate receipt when claiming on your warranty. So that we can clearly identify the model of your equipment, and for the purposes of our quality control, you will need to give the serial number of your equipment, when contacting the service team. Where possible please have your serial number and your customer number ready when you call our service hotline. It will help us to deal with your request swiftly.

If you cannot find the serial number on your training equipment, our service employees are ready to help.

Service outside the warranty period

We are also happy to issue an individual cost estimate if there is a problem with your fitness equipment after the warranty has expired, or in cases which do not fall under the terms of the warranty, e. g. normal wear and tear. Please contact our customer service team to find a quick and cost-effective solution to your problem. In such a case you will be responsible for the delivery costs.

Communication

Many problems can be solved just by speaking to us as your specialist supplier. We know how important it is to you as a user of the fitness equipment to have problems solved quickly and simply, so you can enjoy working out with minimal interruption. For that reason, we also want to resolve your queries quickly and in a straightforward manner. Thus, please always keep your customer number and the serial number of the faulty equipment handy.

6 DISPOSAL

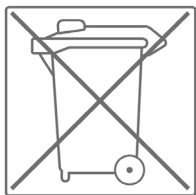

At the end of its operational life, this equipment cannot be disposed of in normal household waste. Instead, it must be disposed of via an electricals recycling centre. Further information can be obtained from your local authority's recycling service.

The materials can be recycled as per their symbols. Through the reuse, recycling of materials or other forms of recovery of old equipment, you make an important contribution to the protection of the environment.

7.1 Service hotline

So that we can give you the best possible service, please have your **model name, part number, serial number, exploded drawing and parts list** ready.

SERVICE-HOTLINE

DE	DK	FR
<p>☎ +49 4621 4210-0</p> <p>☎ +49 4621 4210-699</p> <p>✉ service@sport-tiedje.de</p> <p>Mo. - Fr. 8:00 - 18:00</p> <p>Sa. 9:00 - 18:00</p>	<p>☎ 80 90 16 50</p> <p>☎ +49 4621 4210-945</p> <p>✉ info@t-fitness.dk</p> <p>Ma. - Fr. 8:00 - 18:00</p> <p>Lø. 9:00 - 18:00</p>	<p>☎ +33 (0) 172 770033</p> <p>☎ +49 4621 4210-933</p> <p>✉ service-france@sport-tiedje.fr</p> <p>Lun. - Ven. 8:00 - 18:00</p> <p>Sam. 9:00 - 18:00</p>
NL	UK	INT
<p>☎ +31 172 619961</p> <p>✉ info@fitshop.nl</p> <p>Ma. - Do. 9:00 - 17:00</p> <p>Vr. 9:00 - 21:00</p> <p>Za. 10:00 - 17:00</p>	<p>☎ +44 141 876 3972</p> <p>✉ orders@powerhousefitness.co.uk</p> <p>Mon. - Fri. 9:00 - 17:00</p>	<p>☎ +49 4621 4210-0</p> <p>✉ service-int@sport-tiedje.de</p> <p>Mon - Fri 8:00 - 18:00</p> <p>Sat 9:00 - 18:00</p>

7.2 Serial number and model name

Before assembling your equipment, find the serial number on the white sticker and enter it in the appropriate space.

Serial number:

Brand / category:

Model name:

7.3 Parts list

No.	Description	Qty.
01	Main Frame	1
02	Support Frame	1
03	Base Frame	2
04	Foot Tube	1
05	Carriage	1
06	Right Backrest Frame	1
07	Left Backrest Frame	1
08	Backrest Support	1
09	Backrest Cushion	1
10	Seat Cushion	1
11L	Long Knob	1
11S	Short Knob	1
12	Small Cover	2
13	Big Cover	4
14	Carriage Sleeve	2
15	Backrest Frame Cap	4
16	M10*180mm Hex Bolt	2
17	M10*100mm Hex Bolt	1
18	M10*75 Bolt	1
19	M8*20mm Hex Bolt	11
20	M8*50mm Hex Bolt	4
21	M10 Washer	8
22	M8 Washer	15
23	M10 Locknut	4
24	Bushing	2

7.4 Exploded drawing

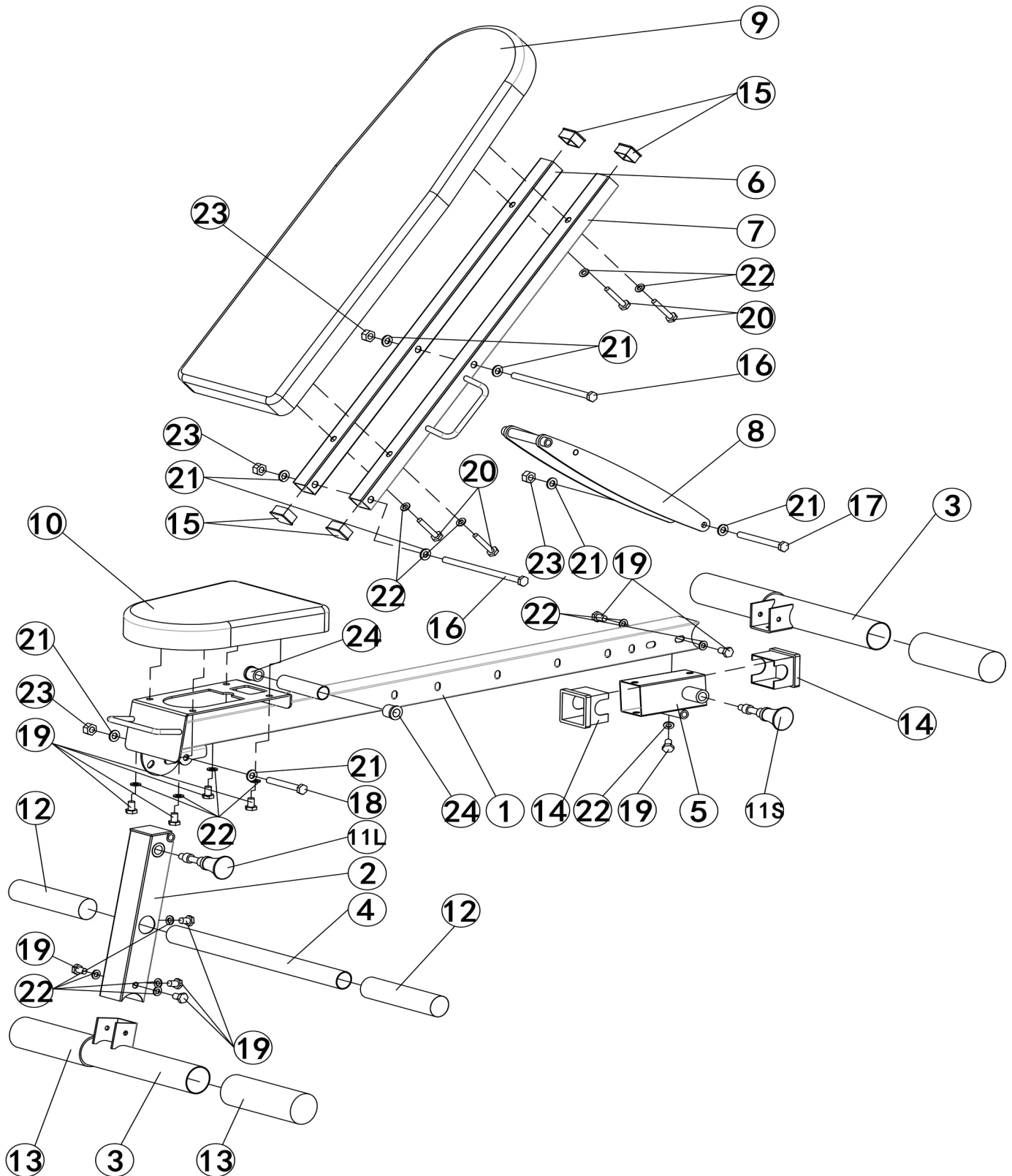















CONTACT

Head office

Powerhouse Fitness
Cloberfield House,
57 Beardmore Way,
Clydebank Industrial Estate,
Clydebank, Glasgow,
G81 4HT

Hotline for Technical Information

DE	DK	FR
 +49 4621 4210-0	 80 90 16 50	 +33 (0) 172 770033
 +49 4621 4210-698	 +49 4621 4210-945	 +49 4621 4210-933
 technik@sport-tiedje.de	 info@t-fitness.dk	 service-france@sport-tiedje.fr
NL	UK	INT
 +31 172 619961	 +44 141 876 3986	 +49 4621 4210-0
 info@fitshop.nl	 support@powerhousefitness.co.uk	 service-int@sport-tiedje.de

www.powerhouse-fitness.co.uk
www.bodymax-fitness.com

DISCLAIMER



©2011 BodyMax is a registered brand of the company Sport-Tiedje GmbH. All rights reserved. Any use of this trademark without the explicit written permission of Sport-Tiedje is prohibited.

Product and instructions are subject to change. Technical data can be changed without advance notice.

Please find a detailed overview including address and opening hours for all specialist fitness stores of the Sport-Tiedje Group in Germany and abroad on the following website.

www.sport-tiedje.com/en/stores

