

BodyMax

Assembly and Operating Instructions

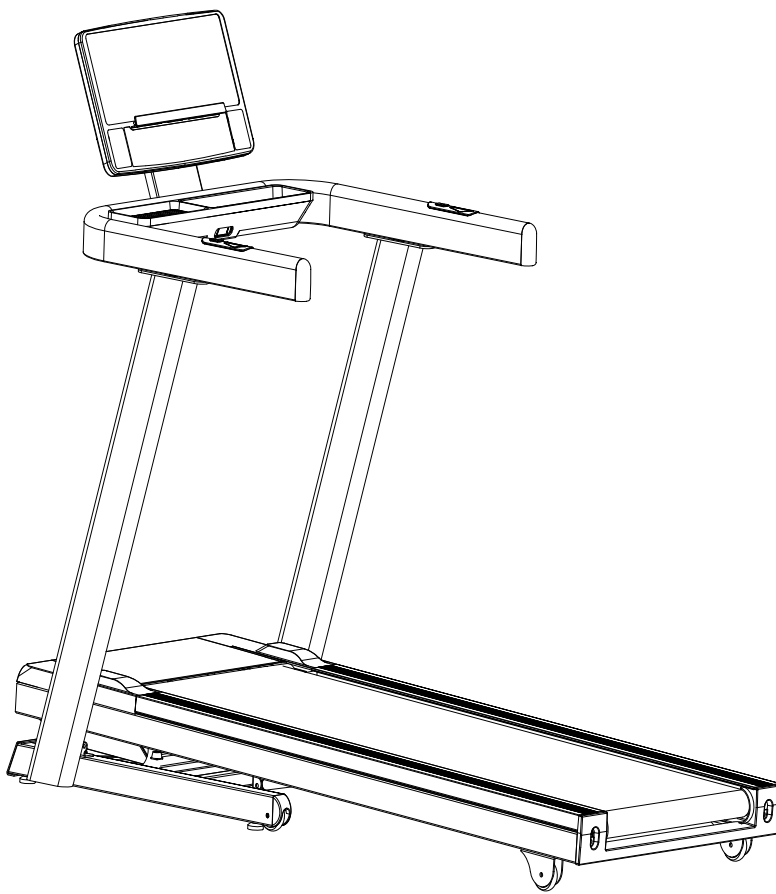

max. 130 kg



~ 60 Min.



33 kg

L 108 | W 56 | H 139

FSUKBMTM50.01.02

SKU: BM-TM50

BodyMax TM50

Content

1	GENERAL INFORMATION	8
1.1	Technical Data	8
1.2	Personal Safety	9
1.3	Electrical Safety	10
1.4	Set-Up Place	11
2	ASSEMBLY	12
2.1	General Instructions	12
2.2	Scope of Delivery	13
2.3	Assembly	15
3	OPERATING INSTRUCTIONS	21
3.1	Console Display	22
3.2	Button Functions	23
3.3	Programmes	24
3.3.1	Quick Start	24
3.3.2	Manual Programme	24
3.3.3	Pre-set Programmes	25
3.3.4	User Programmes	30
3.4	Heart Rate Controlled Programmes	31
3.5	Wireless Connection and Fitness Apps	32
4	STORAGE AND TRANSPORT	33
4.1	General Instructions	33
4.2	Transportation Wheels	33
4.3	Folding Mechanism	33
4.3.1	Folding Up the Treadmill	34
4.3.2	Unfolding the Treadmill	34
5	TROUBLESHOOTING, CARE AND MAINTENANCE	35
5.1	General Instructions	35
5.2	Faults and Fault Diagnosis	35
5.3	Care and Maintenance	36
5.3.1	Adjusting the Running Mat	36
5.3.2	Re-tensioning the Running Mat	37
5.3.3	Lubricating the Running Mat	37
5.4	Maintenance and Inspection Calendar	38

6	DISPOSAL	38
7	RECOMMENDED ACCESSORIES	39
8	ORDERING SPARE PARTS	40
8.1	Serial Number and Model Name	40
8.2	Parts List	41
8.3	Exploded Drawing	45
9	WARRANTY	46
10	CONTACT	48

Dear customer,

Thank you for choosing training equipment from BodyMax.

BodyMax is your reliable partner for home and commercial gym equipment. We are specialized in cardio and strength training machines for home and commercial use. Our products are not only strong, durable, and affordable but also designed to fit your personal needs.

The BodyMax headquarter is based in Rutherglen, Glasgow. Our brand was created with the intention of providing innovative exercise equipment at affordable prices for users of all training levels.

You can find further information at www.bodymax-fitness.com.

Intended Use

The equipment may only be used for its intended purpose.

The equipment is only suitable for home use. The equipment is not suitable for semi-professional (e.g. hospitals, associations, hotels, schools, etc.) and commercial or professional use (e.g. fitness studios).

Legal Notice

Fitshop GmbH
Europe's No. 1 for home fitness

International Headquarters
Flensburger Straße 55
24837 Schleswig
Germany

Management:
Christian Grau
Sebastian Campmann
Dr. Bernhard Schenkel
No. HRB 1000 SL
Local Court Flensburg
European VAT Number: DE813211547

Disclaimer

© BodyMax is a registered brand of the company Fitshop GmbH. All rights reserved. Any use of this trademark without the explicit written permission of Fitshop is prohibited.

Product and manual are subject to change. Technical data can be changed without advance notice.

FITSHOP

Europe's No.1 for Home Fitness

ABOUT THIS MANUAL

Please carefully read the entire manual before installation and first use. The manual will help you to quickly set up the system and explains how to safely use it. Make sure that all persons exercising with the equipment (especially children and persons with physical, sensory, mental or motor disabilities) are informed about this manual and its contents in advance. In case of doubt, responsible persons must supervise the use of the equipment.

Due to ongoing changes and software optimisations, the manual may have to be updated. If you notice any discrepancies during assembly or use, please refer to the manual uploaded to the webshop. The latest manual is always available there.



This equipment has been manufactured according to the latest safety knowledge. As far as possible, potential safety hazards which could cause injury have been eliminated. Make sure to carefully follow the instructions and that all parts are securely in place. If required, read through the instructions again to correct any mistakes.

Training devices must be classified according to accuracy and use. Accuracy classes are only applicable to devices that display training data.

Accuracy classes

Class A: high accuracy.

Class B: medium accuracy.

Class C: low accuracy.

The use classes explain the intended use of the training device.

Use classes

Class S (studio): professional and/or commercial use.

These training devices are intended for the use in training rooms of facilities such as sports clubs, school facilities, hotels, clubs and studios whose access and supervision is specifically regulated by the owner (person with legal responsibility).

Class H (home use): use at home.

These stationary training devices are intended for the use in private homes where access to the training device is regulated by the owner (person with legal responsibility).

Please pay close attention to the safety and maintenance instructions given here. The contract partner cannot be held liable for damage to health, accidents or damage to the equipment when it is not used in accordance with these instructions.

The following safety instructions may appear in this manual:

► **ATTENTION**

This notice indicates potentially hazardous situations which, if not avoided, may result in property damage.

⚠ **CAUTION**

This notice indicates potentially hazardous situations which, if not avoided, may result in slight or minor injuries!

⚠ **WARNING**

This notice indicates potentially hazardous situations which, if not avoided, may result in death or serious injuries!

⚠ **DANGER**

This notice indicates potentially hazardous situations which, if not avoided, will result in death or serious injuries!

ⓘ **NOTICE**

This notice indicates further useful information.

Retain these instructions in a safe place for future reference, maintenance or when ordering replacement parts.

1.1 Technical Data

LED display of:

- + time
- + speed
- + distance
- + calories
- + incline
- + heart rate

Motor output: 2 HP continuous output (DC motor)

Speed range: 1 - 20 km/h (0.1 km/h steps)

Incline range: 0 - 15 % (in 1 % steps)

Total number of training programmes: 43

Manual programmes: 1

Pre-set programmes: 36

User-defined programmes: 3

Heart rate-controlled programmes: 3

Running surface size (L x W): 142 cm x 50 cm

Thickness of running mat: 1.6 mm

Weight and dimensions:

Article weight (gross, including packaging): 89.5

Article weight (net, without packaging): 80

Packaging dimensions (L x W x H): 182.5 cm x 87 cm x 29.5 cm

Set-up dimensions (L x W x H): 172 cm x 83.5 cm x 145 cm

Folded dimensions (L x W x H): 113.5 cm x 79.5 cm x 146 cm

Maximum user weight: 130 kg

Use class: H

1.2 Personal Safety

DANGER

- + Before you start using the equipment, you should consult your physician that this type of exercise is suitable for you from a health perspective. Particularly affected are persons who: have a hereditary disposition to high blood pressure or heart disease, are over the age of 45, smoke, have high cholesterol values, are overweight and/or have not exercised regularly in the past year. If you are under medical treatment that affects your heart rate, medical advice is absolutely essential.
- + Note that excessive training can seriously endanger your health. Please also note that heart rate monitoring systems can be inaccurate. If you notice any signs of weakness, nausea, dizziness, pain, shortness of breath, or other abnormal symptoms, stop exercising immediately and seek advice from your doctor if necessary.
- + The owner must communicate all warnings and instructions to the user.

WARNING

- + This equipment may not be used by children under the age of 14.
- + Children should not be allowed unsupervised access to the equipment.
- + Persons with disabilities must have a medical license and must be under strict observation when using the equipment.
- + The equipment is strictly for use by one person at a time.
- + If your equipment provides a safety key, the clip of the safety key must be attached to your clothing before starting your training. In the event of a fall, the EMERGENCY STOP of the equipment can be initiated.
- + If an emergency occurs and training has to be stopped abruptly, pull out the safety key, grab both handles, jump onto the side rails and wait until the treadmill has come to a complete stop.
- + Keep your hands, feet and other body parts, hair, clothing, jewellery and other objects well clear of moving parts.
- + During use, wear suitable sports clothing rather than loose or baggy clothing. When wearing sports shoes, make sure they have suitable soles, preferably made of rubber or other non-slip materials. Shoes with heels, leather soles, studs or spikes are unsuitable. Never exercise barefoot.

CAUTION

- + If your equipment needs to be connected to the power supply with a mains cable, make sure that the cable is not a potential tripping hazard.
- + Make sure that nobody is within the range of motion of the equipment during training so as not to endanger you or other persons.
- + Be aware that if adjustment devices are left protruding, they may impede the user's movement.

► **ATTENTION**

- + Do not insert any objects of any kind into the openings of the device.
- + To protect the equipment from use by unauthorised third parties, always remove the power cable (if existing) when not in use and store it in a safe place that is inaccessible to unauthorised persons (e.g. children).

1.3 Electrical Safety

 **DANGER**

- + In order to reduce the risk of an electric shock, always unplug the equipment from the mains socket immediately after your workout, before assembly or dismantling, and before maintenance or cleaning. Do not pull on the cable.

 **WARNING**

- + Do not leave the equipment unattended while the mains cable is plugged into the mains socket. During your absence, the mains cable must be removed from the mains socket to prevent improper use by third parties or children.
- + If the mains cable or plug is damaged or defective, contact your contract partner. Until repair, the equipment must not be used.

► **ATTENTION**

- + The equipment requires a mains connection of 220-230 V with 50 Hz mains voltage.
- + The equipment may only be connected directly to an earthed socket using the supplied mains cable. Extension cables must conform to VDE guidelines. Always completely unwind the mains cable.
- + The socket must be protected by a fuse with a minimum fuse rating of "16 A, slow blow".
- + Do not make any changes to the mains cable or the mains plug.
- + Keep the mains cable away from water, heat, oil and sharp edges. Do not route the mains cable underneath the equipment or under a carpet or rug, and do not place any objects on top of it.
- + If your purchased item is equipped with a TFT console, software updates must be carried out regularly. Follow the instructions on the console to perform the update(s).
- + The software systems on gym equipment with TFT consoles are set up only for the pre-installed apps. Do not install any additional apps.

 **NOTICE**

- + The pre-installed apps on TFT consoles are produced and provided by external manufacturers. Fitshop does not take any responsibility for the availability, functionality or contents of these apps.

1.4 Set-Up Place

⚠ WARNING

- + Do not place the equipment in main corridors or escape routes.

⚠ CAUTION

- + Make sure that there is a safety area behind the treadmill with a length of at least 2 m and a width at least equal to the width of the treadmill.
- + The training room should be well ventilated during training and not be exposed to any draughts.
- + Choose the place in which to set up the equipment such that there is enough free space/clearance to the front, the rear and to the sides of the equipment.
- + The free area in the direction from which the exercise equipment is accessed must be at least 0.6 m larger than the exercise area.
- + The set-up and mounting surface of the equipment should be flat, loadable and solid.

▶ ATTENTION

- + The device may only be used in one building, in sufficiently tempered and dry rooms (ambient temperatures between 10°C and 35°C). The equipment should not be used outdoors or in rooms with high humidity (over 70%) like swimming pools.
- + A floor protective mat/equipment underlay can help to protect high-quality floor coverings (parquet, laminate, cork, carpets) from dents and sweat and can help to level out slight unevenness.
- + For Class S equipment, the exercise equipment may only be used in areas where access, supervision and control are specifically regulated by the owner.

Recommended free zone:

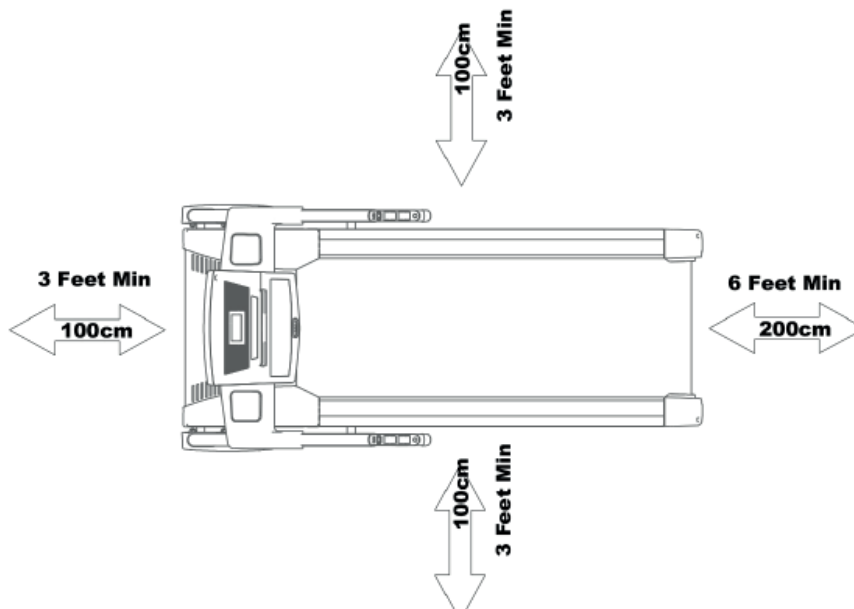

2.1 General Instructions

DANGER

- + Do not leave any tools, packaging materials such as foils or small parts lying around, as otherwise there is a danger of suffocation for children. Keep children away from the equipment during assembly.

WARNING

- + The treadmill is equipped with high-pressure shock absorbers that can cause the treadmill to suddenly open if handled incorrectly. To avoid possible personal injuries, never pull on the areas of the treadmill shown in the illustration. Never try to lift or move the treadmill at the marked areas.
- + Pay attention to the instructions attached to the equipment in order to reduce the risk of injuries.

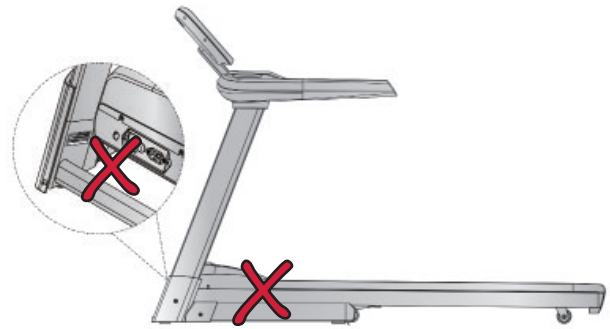

CAUTION

- + Ensure to have sufficient room for movement in each direction during assembly.
- + The assembly of the equipment must be carried out by at least two adults. If in doubt, seek the help of a third technically skilled person.

ATTENTION

- + To prevent damage to the equipment and the floor, assemble the equipment on a mat or packaging board.

NOTICE

- + In order to make the assembly as simple as possible, some screws and nuts to be used can already be pre-assembled.
- + Ideally, assemble the equipment at its later set-up place.

2.2 Scope of Delivery

WARNING

There is a transportation lock that prevents the treadmill from opening during transport. This transportation lock must be removed before assembly.

The scope of delivery consist of the following parts. At the beginning, check whether all parts and tools belonging to the device are included in the scope of delivery and whether damage has occurred. In the event of complaints, the contractual partner must be contacted directly.

CAUTION

If parts of the scope of delivery are missing or damaged, the assembly must not be carried out.

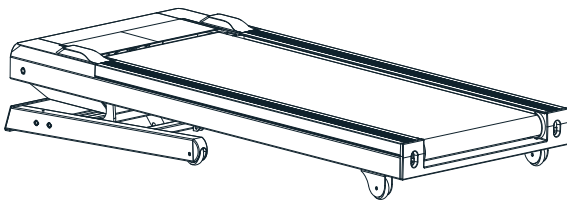

Main frame

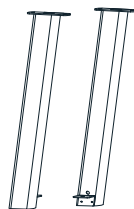

Upright post L & R

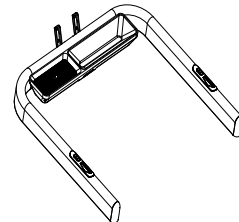

Console frame welds

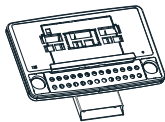

Console



Safety key

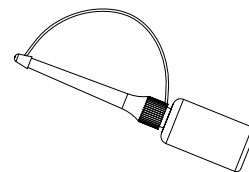

Silicone oil



Manual

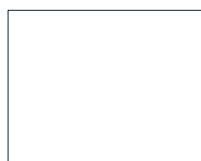

Screw kit

Hardware Pack List

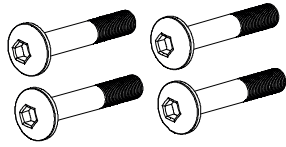

Hexagon large flat head half tooth bolt (M8*50*20) 4pcs

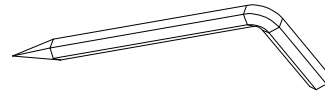

L shape wrench S4 1pcs

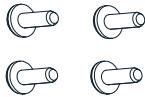

Hexagon pan head full tooth bolt (M6*10) 4pcs

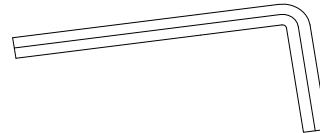

L shape wrench S6 1pcs

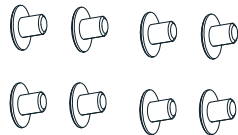

Hexagon large flat head full tooth bolt M8×15 8pcs

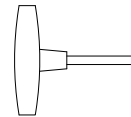

T shape wrench 6x80 1pcs

2.3 Assembly

Before assembly, take a close look at the individual assembly steps shown and carry out the assembly in the order given.

① NOTICE

- + First loosely screw all parts together and check that they fit properly. Tighten the screws using the tool only when you are instructed to do so.
- + If you have difficulty recognising the graphics, we recommend that you open and/or download the PDF instructions stored in the webshop on your end device (e.g. smartphone, tablet or PC). There you have the option of zooming in closer. Please note that the Adobe Acrobat Reader programme must be installed on your end device in order to open the file.

Overview

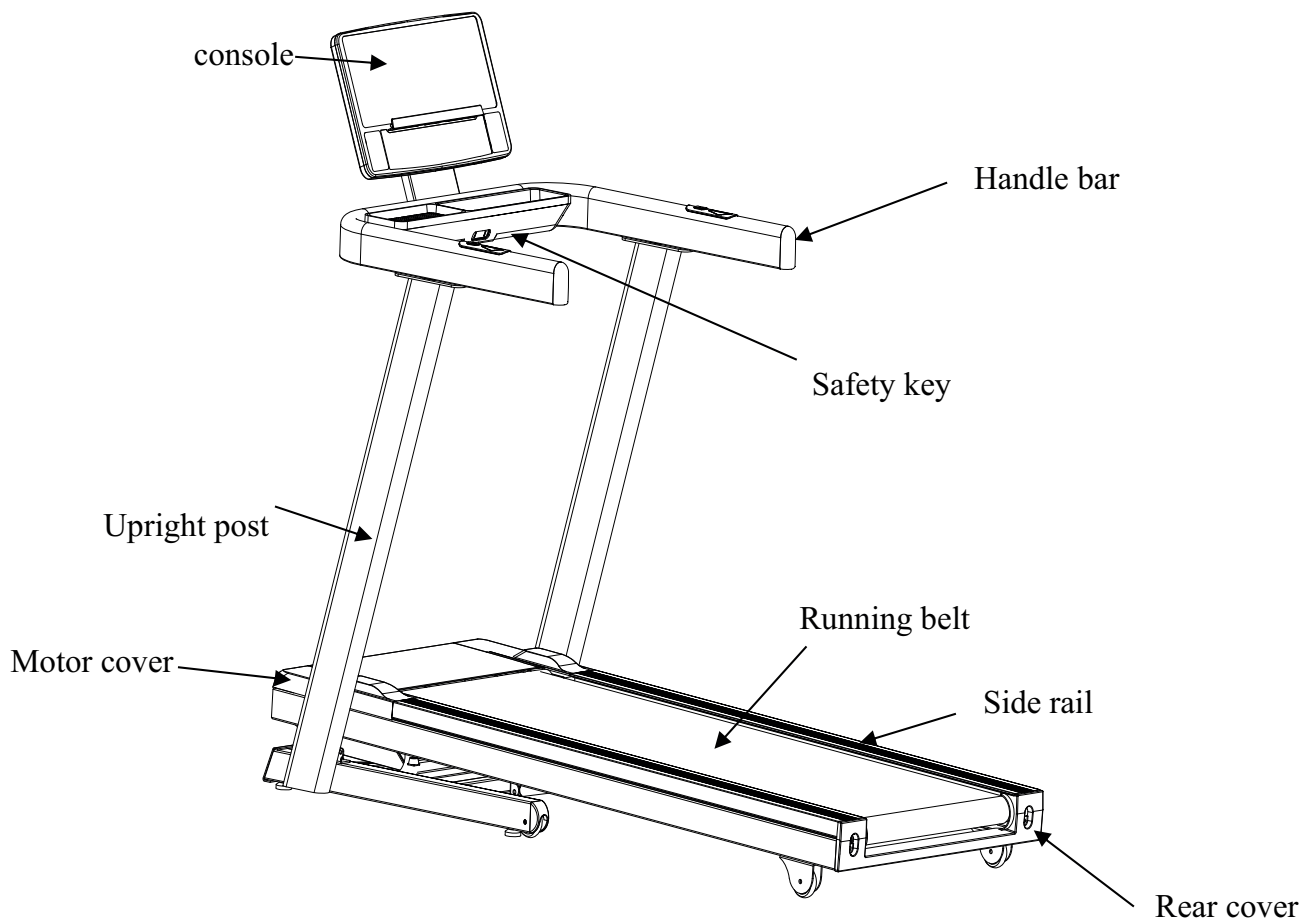

Step 1: Unpacking

1. Lift the equipment out of the box and place it on a flat surface.
2. Remove all packaging material from the equipment.

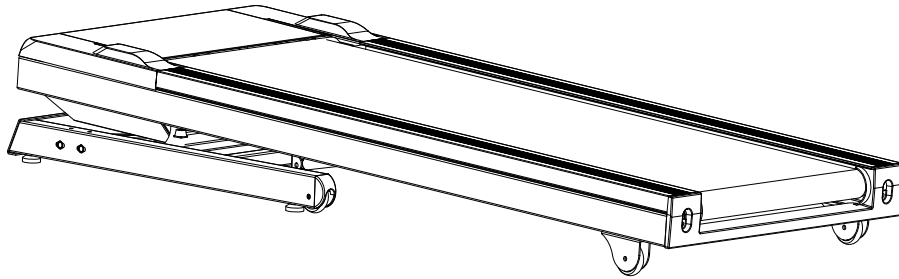

Step 2: Assembly of the Upright Posts

1. Place the treadmill in an upright position.
2. Assemble the left upright post (62) to the corresponding position of the base weldment (1) with two bolts (103) and two bolts (104).

► ATTENTION

Be careful not to pinch the cables in the following step.

3. Connect the two cables (35 and 64) with one another and repeat the previous steps for the right upright post (63).

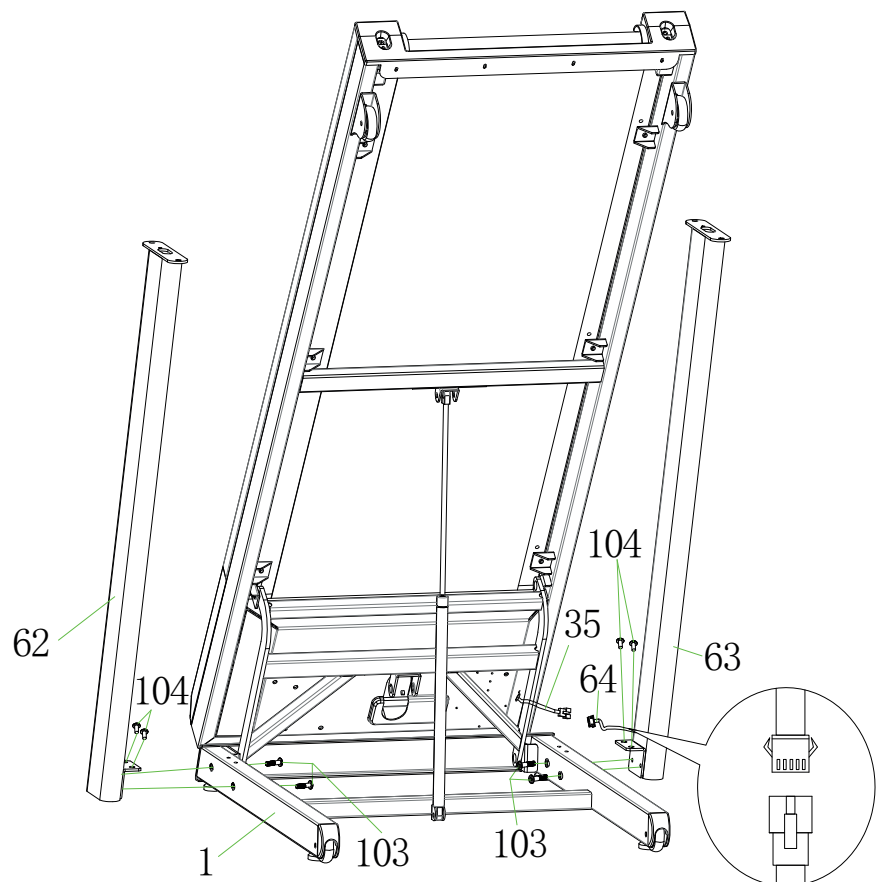

Step 3: Assembly of the Handrail

► **ATTENTION**

Be careful not to pinch the cables in the following step.

1. Connect the two cables (64 and 86) on the right side of the console frame weld with one another.
2. Assemble the console frame weld (24) to the upright posts (62 & 63) with four bolts (104).

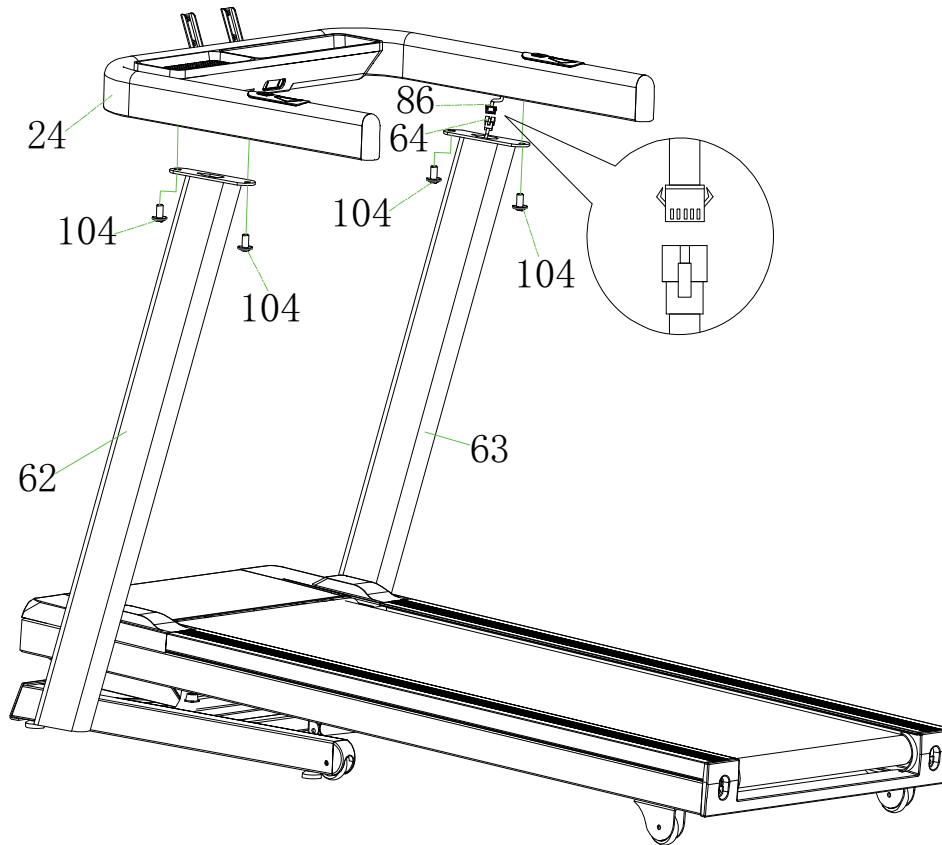

Step 4: Assembly of the Console

► ATTENTION

Be careful not to pinch the cables in the following step.

1. Connect the cables (86 and 88) with one another.
2. Insert the console fixed welds (72) to the console frame weld (24) with four bolts (105).

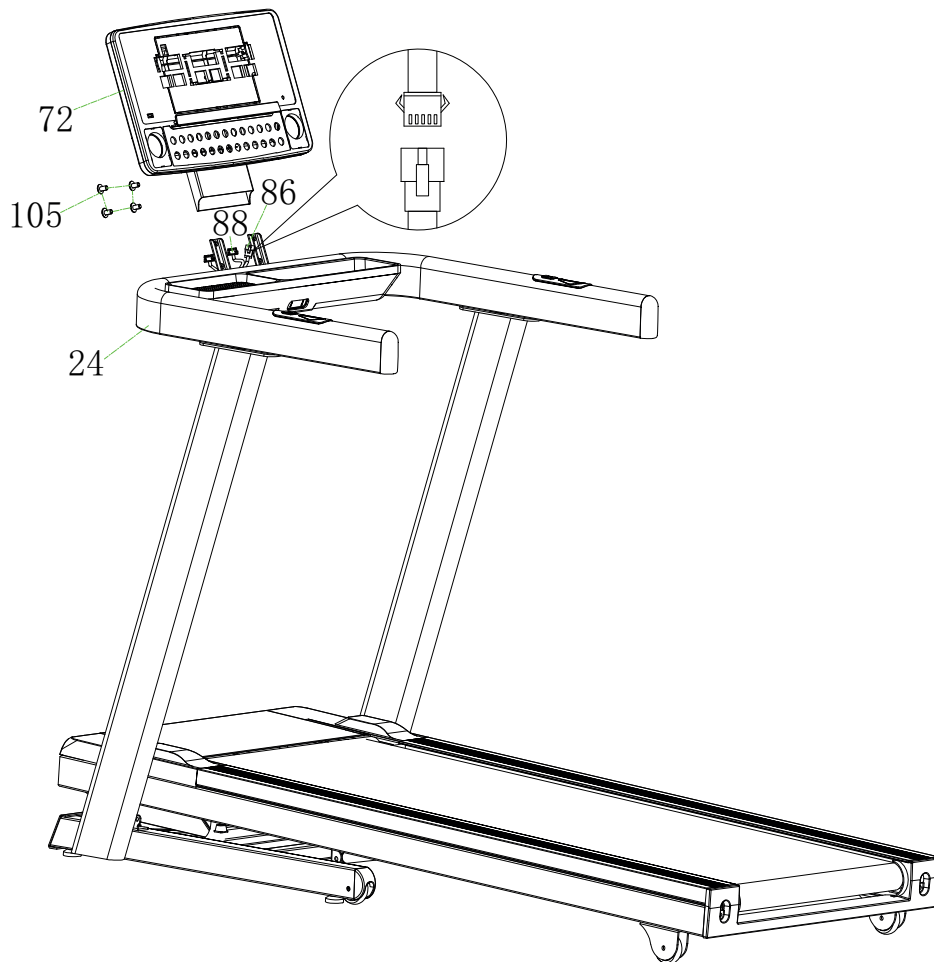

Step 5: Assembly of the Safety Key

1. Set up the treadmill and tighten all bolts.
2. Assemble the safety key (89).

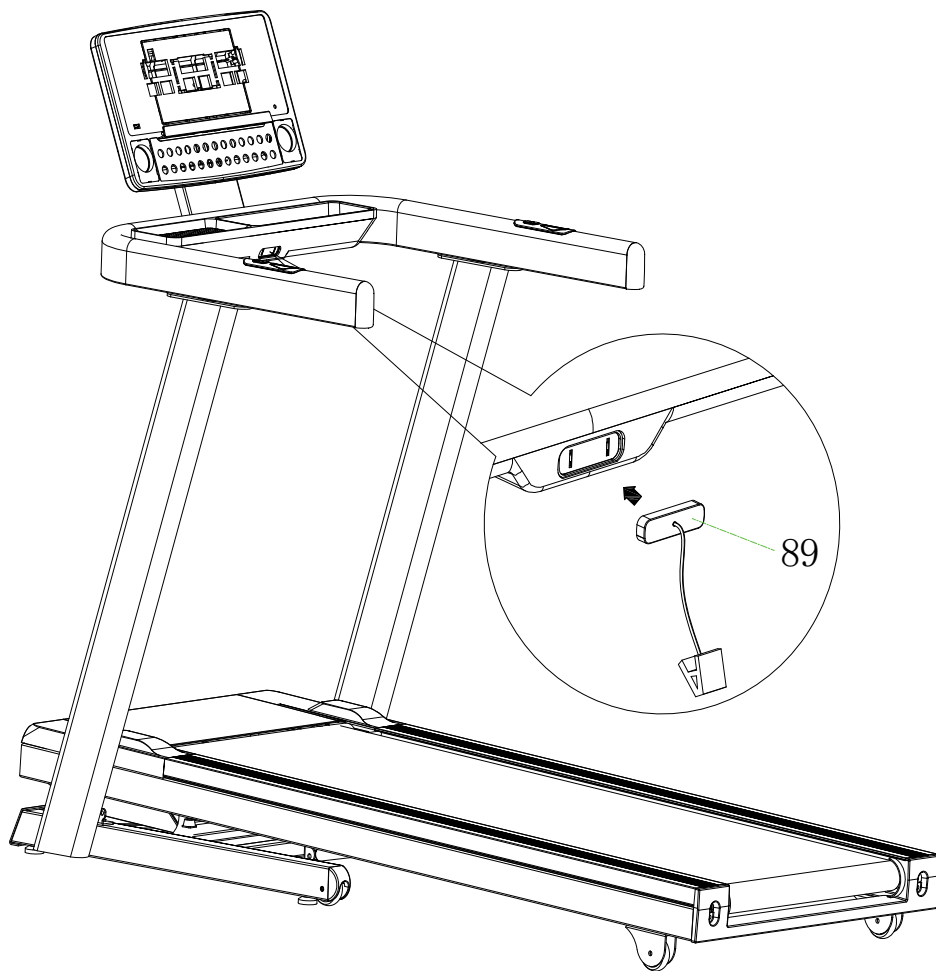

Step 6: Alignment of the Feet

If the floor is uneven, you can stabilize the treadmill by turning the two setting screws under the main frame.

WARNING

The treadmill is equipped with high-pressure shock absorbers that can cause the treadmill to suddenly open if handled incorrectly. For more information, refer to the section 2.1 of this manual.

1. Lift the treadmill on the desired side and rotate the setting screws under the main frame.
2. Rotate the screws clockwise in order to remove them and to raise the running surface.
3. Rotate them counterclockwise in order to lower the running surface.

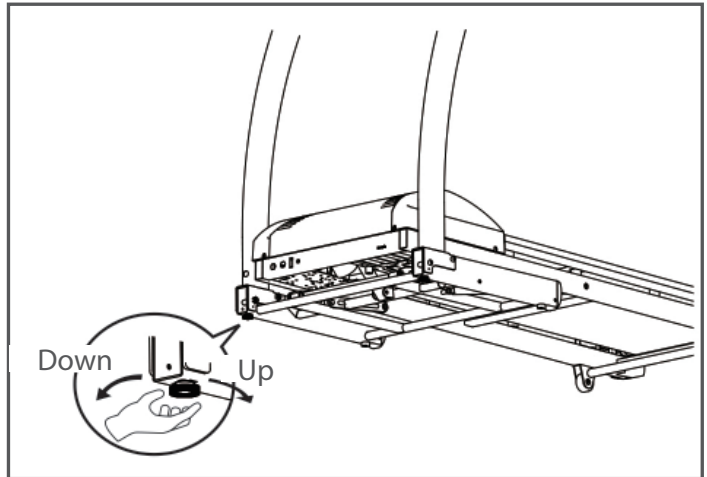

Step 7: Connecting the Equipment to the Mains supply

ATTENTION

The equipment must not be connected to a multiple socket, otherwise it cannot be guaranteed that the equipment will be supplied with sufficient power. Technical errors can result.

Plug the power plug into a wall outlet that complies with the instructions in the chapter on electrical safety.

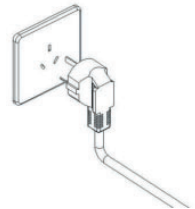

Correctly Getting On and Off

1. To step onto the treadmill, grip the handrails with both hands and step onto the treadmill one foot at a time.
2. To get off, grip the handrails with both hands and step off the treadmill one foot at a time.

3 OPERATING INSTRUCTIONS

NOTICE

- + Familiarise yourself with all the functions and setting options of the device before starting training. Have the proper use of this product explained to you by a specialist.
- + Always start your training with low intensity and increase evenly and gently. End your training with a cool-down phase. If you are unsure, please consult your physician.
- + Most new treadmills make a knocking noise caused by the running mat sliding over the rollers. The time it takes for the noise to subside depends on the intensity of use, the temperature and the humidity around the treadmill.
- + Please bear in mind that the noise emission under load is higher than without load.

SAFETY KEY

WARNING

- + For your safety, the device is equipped with an EMERGENCY STOP function. The equipment can only be operated if the safety key is correctly attached to the contact point of the cockpit. If the safety key is no longer on the contact point, the equipment automatically stops. Therefore, the Safety Key cord with the clip must be attached to your clothing before every training session. If you want to quickly stop the treadmill, if you can no longer control the speed, or if another emergency occurs, remove the safety key from the cockpit using the cord.
- + To enable the safety key to detach from the contact point of the cockpit in the event of a fall, the safety key clip must be firmly attached to your clothing!
- + Make sure that the safety key is not accessible to children.

3.1 Console Display



DISPLAY	DESCRIPTION
Incline	+ Display of the current incline in % + Display range: 0–15
Distance	+ Display of the training distance in km + Display range: 1–99
Time	+ Display of the training time in minutes + Display range: 05:00–99:00
Calories	+ Display of the calories in kcal + Display range: 20–999
Speed	+ Display of the current speed in km/h + Display range: 1.0–20
Pulse	+ Display of the current heart rate + Display range: 80–220

3.2 Button Functions

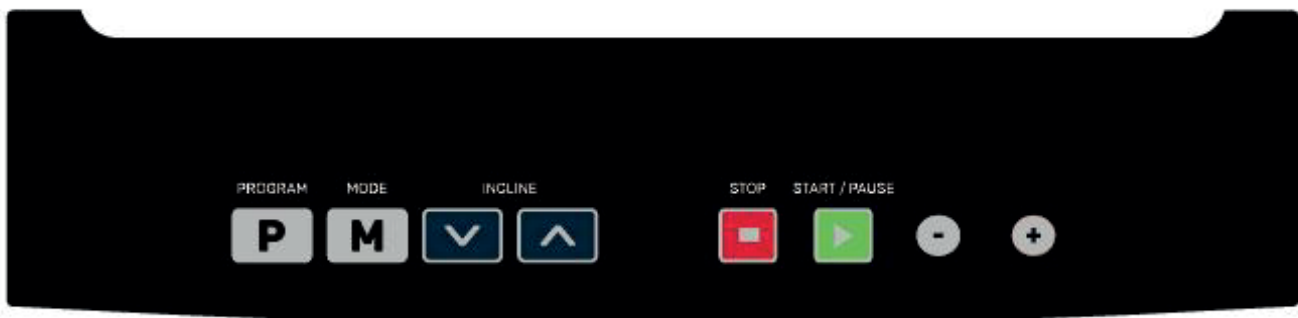

BUTTON	DESCRIPTION
START/PAUSE	With this button you can start or pause a training programme. When you are in the main menu, you can start your training via quick start. When your training is paused, you can continue with your training by pressing this button.
STOP	With this button you can end your training and return to the main menu.
SPEED + / -	<ul style="list-style-type: none"> + With these buttons you can adjust the respective training parameters (time, distance, calories etc.) + With these buttons you can adjust the speed. You can adjust the speed in two ways: <ol style="list-style-type: none"> 1. The buttons on the console (+ and -). 2. The buttons on the handrail.
INCLINE ▼▲	With these buttons you can adjust the incline. You can adjust the incline in two ways: <ol style="list-style-type: none"> 1. The arrow buttons on the console. 2. The buttons on the handrail.
MODE (M)	With this button you confirm your entries.
PROGRAM (P)	With this button you choose your desired training programme.

3.3 Programmes

In total, 43 programmes are available to you:

- + Manual programme: 1
- + Pre-set programmes: 36
- + Heart rate controlled programmes: 3
- + User-defined programmes: 3

3.3.1 Quick Start

1. When you are in the main menu, press the START/PAUSE button to start the training.

A countdown of 5 seconds is started. All values will start to count up.

NOTICE

During training, the speed/incline can be adjusted using the corresponding buttons.

2. Press the START/PAUSE button to pause the training.
3. Press the START/PAUSE button again to continue the training.
4. Press the STOP button to end your training.

3.3.2 Manual Programme

Within the manual programme, you have the option of adjusting your training depending on one, several or all of the target values.

1. When you are in the main menu, press the PROGRAM button to select the manual programme. Confirm the selection with the MODE button.
2. Adjust the desired values (time, calories, distance, etc.) using the +/- buttons and confirm with the MODE button.
3. Press the START/PAUSE button to start the training.

A countdown of 5 seconds is started. The values you enter are counted up, while the remaining values are counted down.

NOTICE

During training, the speed/incline can be adjusted using the corresponding buttons.

4. Press the START/PAUSE button to pause the training.
5. Press the START/PAUSE button again to continue the training.
6. Press the STOP button to end your training.

3.3.3 Pre-set Programmes

A total of 36 pre-set programmes (P01-P36) are available.

1. When you are in the main menu, press the PROGRAM button to select one of the profile programmes. Confirm your selection with the MODE button.
2. Adjust the training time using the +/- buttons and confirm with the MODE button.
3. Press the START/PAUSE button to start the training.

A countdown of 5 seconds is started.

① NOTICE

During training, the speed/incline can be adjusted using the corresponding buttons. However, the adjustment is only made for the segment you are currently training.

4. Press the START/PAUSE button to pause the training.
5. Press the START/PAUSE button again to continue the training.
6. Press the STOP button to end your training.

① NOTICE

Setting time / 10 = duration of each section.

Metric

Pro	Seg Class	1	2	3	4	5	6	7	8	9	10
		P1	SPEED	1.0	3.0	5.0	5.0	5.0	7.0	7.0	5.0
	INCLINE	2	2	8	6	6	4	4	6	2	2
P2	SPEED	2.0	3.0	5.0	8.0	5.0	5.0	6.0	8.0	4.0	3.0
	INCLINE	3	3	2	2	8	8	4	4	4	4
P3	SPEED	2.0	3.0	7.0	8.0	5.0	5.0	5.0	8.0	4.0	3.0
	INCLINE	1	2	5	7	7	4	4	6	2	2
P4	SPEED	2.0	2.0	5.0	8.0	8.0	8.0	8.0	5.0	3.0	2.0
	INCLINE	3	3	9	9	9	9	9	6	2	2
P5	SPEED	3.0	4.0	8.0	9.0	10.0	10.0	10.0	7.0	4.0	3.0
	INCLINE	2	2	8	6	6	6	6	6	1	1
P6	SPEED	3.0	4.0	6.0	7.0	7.0	7.0	9.0	10.0	5.0	3.0
	INCLINE	1	8	8	7	7	7	7	5	3	1
P7	SPEED	3.0	4.0	4.0	10.0	4.0	9.0	4.0	11.0	3.0	2.0
	INCLINE	1	1	6	6	6	8	8	10	6	2
P8	SPEED	3.0	5.0	7.0	9.0	3.0	5.0	7.0	5.0	11.0	5.0
	INCLINE	3	3	3	7	7	3	3	3	5	5
P9	SPEED	3.0	7.0	10.0	4.0	7.0	11.0	5.0	4.0	12.0	6.0
	INCLINE	3	6	7	3	8	8	3	8	4	4
P10	SPEED	3.0	5.0	9.0	10.0	6.0	6.0	9.0	6.0	11.0	3.0
	INCLINE	2	7	5	5	8	8	8	8	4	4
P11	SPEED	4.0	5.0	11.0	9.0	6.0	8.0	9.0	11.0	6.0	5.0
	INCLINE	1	6	3	3	7	7	4	4	6	6
P12	SPEED	4.0	6.0	10.0	10.0	10.0	7.0	7.0	10.0	6.0	5.0
	INCLINE	3	8	9	5	5	8	8	4	4	4
P13	SPEED	2.0	4.0	6.0	6.0	6.0	8.0	8.0	6.0	4.0	3.0

	INCLINE	3	3	9	7	7	5	5	7	3	3
P14	SPEED	3.0	4.0	6.0	9.0	6.0	6.0	7.0	9.0	5.0	4.0
	INCLINE	4	4	3	3	9	9	5	5	5	5
P15	SPEED	3.0	4.0	8.0	9.0	6.0	6.0	6.0	9.0	5.0	4.0
	INCLINE	2	3	6	8	8	5	5	7	3	3
P16	SPEED	3.0	3.0	6.0	9.0	9.0	9.0	9.0	6.0	4.0	3.0
	INCLINE	4	4	10	10	10	10	10	7	3	3
P17	SPEED	4.0	5.0	9.0	10.0	11.0	11.0	11.0	8.0	5.0	4.0
	INCLINE	3	3	9	7	7	7	7	7	2	2
P18	SPEED	4.0	5.0	7.0	8.0	8.0	8.0	10.0	11.0	6.0	4.0
	INCLINE	2	9	9	8	8	8	8	6	4	2
P19	SPEED	4.0	5.0	5.0	11.0	5.0	10.0	5.0	12.0	4.0	3.0
	INCLINE	2.0	2	7	7	7	9	9	11	7	3
P20	SPEED	4.0	6.0	8.0	10.0	4.0	6.0	8.0	6.0	12.0	6.0
	INCLINE	4	4	4	8	8	4	4	4	6	6
P21	SPEED	4.0	8.0	11.0	5.0	8.0	12.0	6.0	5.0	12.0	7.0
	INCLINE	4	7	8	4	9	9	4	9	5	5
P22	SPEED	4.0	6.0	10.0	11.0	7.0	7.0	10.0	7.0	12.0	4.0
	INCLINE	3	8	6	6	9	9	9	9	5	5
P23	SPEED	5.0	6.0	12.0	10.0	7.0	9.0	10.0	12.0	7.0	6.0
	INCLINE	2	7	4	4	8	8	5	5	7	7
P24	SPEED	5.0	7.0	11.0	11.0	11.0	8.0	8.0	11.0	7.0	6.0
	INCLINE	4	9	10	6	6	9	9	5	5	5
P25	SPEED	3.0	5.0	7.0	7.0	7.0	9.0	9.0	7.0	5.0	4.0
	INCLINE	4	4	10	8	8	6	6	8	4	4
P26	SPEED	4.0	5.0	7.0	10.0	7.0	7.0	8.0	10.0	6.0	5.0
	INCLINE	5	5	4	4	10	10	6	6	6	6
P27	SPEED	4.0	5.0	9.0	10.0	7.0	7.0	7.0	10.0	6.0	5.0
	INCLINE	3	4	7	9	9	6	6	8	4	4
P28	SPEED	4.0	4.0	7.0	10.0	10.0	10.0	10.0	7.0	5.0	4.0
	INCLINE	5	5	11	11	11	11	11	8	4	4
P29	SPEED	5.0	6.0	10.0	11.0	12.0	12.0	12.0	9.0	6.0	5.0
	INCLINE	4	4	10	8	8	8	8	8	3	3
P30	SPEED	5.0	6.0	8.0	9.0	9.0	9.0	11.0	12.0	7.0	5.0
	INCLINE	3	10	10	9	9	9	9	7	5	3
P31	SPEED	5.0	6.0	6.0	12.0	6.0	11.0	6.0	12.0	5.0	4.0
	INCLINE	3	3	8	8	8	10	10	12	8	4
P32	SPEED	5.0	7.0	9.0	11.0	5.0	7.0	9.0	7.0	12.0	7.0
	INCLINE	5	5	5	9	9	5	5	5	7	7
P33	SPEED	5.0	9.0	12.0	6.0	9.0	12.0	7.0	6.0	12.0	8.0
	INCLINE	5	8	9	5	10	10	5	10	6	6
P34	SPEED	5.0	7.0	11.0	12.0	8.0	8.0	11.0	8.0	12.0	5.0
	INCLINE	4	9	7	7	10	10	10	10	6	6
P35	SPEED	6.0	7.0	12.0	11.0	8.0	10.0	11.0	12.0	8.0	7.0

	INCLINE	3	8	5	5	9	9	6	6	8	8
P36	SPEED	6.0	8.0	12.0	12.0	12.0	9.0	9.0	12.0	8.0	7.0
	INCLINE	5	10	11	7	7	10	10	6	6	6

Imperial

Pro	Seg Class	1	2	3	4	5	6	7	8	9	10
		P1	SPEED	0.6	1.8	3.1	3.1	3.1	4.3	4.3	3.1
	INCLINE	2	2	8	6	6	4	4	6	2	2
P2	SPEED	1.2	1.8	3.1	5	3.1	3.1	3.7	5	2.5	1.8
	INCLINE	3	3	2	2	8	8	4	4	4	4
P3	SPEED	1.2	1.8	4.3	5	3.1	3.1	3.1	5	2.5	1.8
	INCLINE	1	2	5	7	7	4	4	6	2	2
P4	SPEED	1.2	1.2	3.1	5	5	5	5.0	3.1	1.8	1.2
	INCLINE	3	3	9	9	9	9	9	6	2	2
P5	SPEED	1.8	2.5	5	5.6	6.2	6.2	6.2	4.3	2.5	1.8
	INCLINE	2	2	8	6	6	6	6	6	1	1
P6	SPEED	1.8	2.5	3.7	4.3	4.3	4.3	5.6	6.2	3.1	1.8
	INCLINE	1	8	8	7	7	7	7	5	3	1
P7	SPEED	1.8	2.5	2.5	6.2	2.5	5.6	2.5	6.8	1.8	1.2
	INCLINE	1	1	6	6	6	8	8	10	6	2
P8	SPEED	1.8	3.1	4.3	5.6	1.8	3.1	4.3	3.1	6.8	3.1
	INCLINE	3	3	3	7	7	3	3	3	5	5
P9	SPEED	1.8	4.3	6.2	2.5	4.3	6.8	3.1	2.5	7.5	3.7
	INCLINE	3	6	7	3	8	8	3	8	4	4
P10	SPEED	1.8	3.1	5.6	6.2	3.7	3.7	5.6	3.7	6.8	1.8
	INCLINE	2	7	5	5	8	8	8	8	4	4
P11	SPEED	2.5	3.1	6.8	5.6	3.7	5	5.6	6.8	3.7	3.1
	INCLINE	1	6	3	3	7	7	4	4	6	6
P12	SPEED	2.5	3.7	6.2	6.2	6.2	4.3	4.3	6.2	3.7	3.1
	INCLINE	3	8	9	5	5	8	8	4	4	4
P13	SPEED	1.2	2.5	3.7	3.7	3.7	5	5	3.7	2.5	1.8
	INCLINE	3	3	9	7	7	5	5	7	3	3
P14	SPEED	1.8	2.5	3.7	5.6	3.7	3.7	4.3	5.6	3.1	2.5
	INCLINE	4	4	3	3	9	9	5	5	5	5
P15	SPEED	1.8	2.5	5	5.6	3.7	3.7	3.7	5.6	3.1	2.5
	INCLINE	2	3	6	8	8	5	5	7	3	3
P16	SPEED	1.8	1.8	3.7	5.6	5.6	5.6	5.6	3.7	2.5	1.8
	INCLINE	4	4	10	10	10	10	10	7	3	3

P17	SPEED	2.5	3.1	5.6	6.2	6.8	6.8	6.8	5	3.1	2.5
	INCLINE	3	3	9	7	7	7	7	7	2	2
P18	SPEED	2.5	3.1	4.3	5	5	5	6.2	6.8	3.7	2.5
	INCLINE	2	9	9	8	8	8	8	6	4	2
P19	SPEED	2.5	3.1	3.1	6.8	3.1	6.2	3.1	7.5	2.5	1.8
	INCLINE	2	2	7	7	7	9	9	11	7	3
P20	SPEED	2.5	3.7	5	6.2	2.5	3.7	5	3.7	7.5	3.7
	INCLINE	4	4	4	8	8	4	4	4	6	6
P21	SPEED	2.5	5	6.8	3.1	5	7.5	3.7	3.1	7.5	4.3
	INCLINE	4	7	8	4	9	9	4	9	5	5
P22	SPEED	2.5	3.7	6.2	6.8	4.3	4.3	6.2	4.3	7.5	2.5
	INCLINE	3	8	6	6	9	9	9	9	5	5
P23	SPEED	3.1	3.7	7.5	6.2	4.3	5.6	6.2	7.5	4.3	3.7
	INCLINE	2	7	4	4	8	8	5	5	7	7
P24	SPEED	3.1	4.3	6.8	6.8	6.8	5	5	6.8	4.3	3.7
	INCLINE	4	9	10	6	6	9	9	5	5	5
P25	SPEED	1.8	3.1	4.3	4.3	4.3	5.6	5.6	4.3	3.1	2.5
	INCLINE	4	4	10	8	8	6	6	8	4	4
P26	SPEED	2.5	3.1	4.3	6.2	4.3	4.3	5	6.2	3.7	3.1
	INCLINE	5	5	4	4	10	10	6	6	6	6
P27	SPEED	2.5	3.1	5.6	6.2	4.3	4.3	4.3	6.2	3.7	3.1
	INCLINE	3	4	7	9	9	6	6	8	4	4
P28	SPEED	2.5	2.5	4.3	6.2	6.2	6.2	6.2	4.3	3.1	2.5
	INCLINE	5	5	11	11	11	11	11	8	4	4
P29	SPEED	3.1	3.7	6.2	6.8	7.5	7.5	7.5	5.6	3.7	3.1
	INCLINE	4	4	10	8	8	8	8	8	3	3
P30	SPEED	3.1	3.7	5	5.6	5.6	5.6	6.8	7.5	4.3	3.1
	INCLINE	3	10	10	9	9	9	9	7	5	3
P31	SPEED	3.1	3.7	3.7	7.5	3.7	6.8	3.7	7.5	3.1	2.5
	INCLINE	3	3	8	8	8	10	10	12	8	4
P32	SPEED	3.1	4.3	5.6	6.8	3.1	4.3	5.6	4.3	7.5	4.3
	INCLINE	5	5	5	9	9	5	5	5	7	7
P33	SPEED	3.1	5.6	7.5	3.7	5.6	7.5	4.3	3.7	7.5	5
	INCLINE	5	8	9	5	10	10	5	10	6	6
P34	SPEED	3.1	4.3	6.8	7.5	5	5	6.8	5	7.5	3.1
	INCLINE	4	9	7	7	10	10	10	10	6	6
P35	SPEED	3.7	4.3	7.5	6.8	5	6.2	6.8	7.5	5	4.3
	INCLINE	3	8	5	5	9	9	6	6	8	8
P36	SPEED	3.7	5	7.5	7.5	7.5	5.6	5.6	7.5	5	4.3
	INCLINE	5	10	11	7	7	10	10	6	6	6

3.3.4 User Programmes

A total of 3 user programmes are available, which you can customise according to your personal preferences.

1. When you are in the main menu, press the PROGRAM button to select one of the user profiles (U01, U02, U03). Confirm your selection with the MODE button.
2. Adjust the training time using the +/- buttons and confirm with the MODE button
3. Adjust the desired speed for the 10 segments using the +/- buttons and the incline using the arrow buttons. Confirm your entries with the MODE button.
4. Press the START/PAUSE button to start training.

A countdown of 5 seconds is started.

① NOTICE

During training, the speed/incline can be adjusted using the corresponding buttons. However, the adjustment is only made for the segment you are currently training.

5. Press the START/PAUSE button to pause the training.
6. Press the START/PAUSE button again to continue the training.
7. Press the STOP button to end your training.

3.4 Heart Rate Controlled Programmes

WARNING

Your training equipment is not a medical device. The heart rate measurement of this equipment may be inaccurate. Various factors can affect the accuracy of the heart rate measurement. The heart rate measurement serves only as a training aid.

A total of 3 heart rate-controlled programmes are available (speed limit: 9 km/h, 11 km/h, 13 km/h). The hand pulse sensors of the treadmill must be covered during the programme. Alternatively, you can use an optional chest strap.

1. When you are in the main menu, press the PROGRAM button to select one of the heart rate-controlled programmes (HRC1, HRC2, HRC3). Confirm your selection with the MODE button.
2. Enter your age using the +/- buttons and confirm with the MODE button.
3. Set your desired target heart rate value using the +/- buttons (80-220) and confirm with the MODE button.
4. Adjust the training time using the +/- buttons and confirm with the MODE button.
5. Press the START/PAUSE button to start training.

A countdown of 5 seconds is started.

Your heart rate is measured by the console every 30 seconds.

If the user's heart rate is 30 beats/min below the target heart rate, the speed will increase by 2.0 km/h.

If the user's heart rate is 6-29 beats/min below the target heart rate, the speed is increased by 1.0 km/h.

If the user's heart rate is 30 beats/min above the target heart rate, the speed will be reduced by 2.0 km/h.

If the user's heart rate is 6-29 beats/min higher than the target heart rate, the speed will be reduced by 1.0 km/h.

The user's heart rate is above or below the target heart rate 0-5 times/minute, and the speed remains the same.

NOTICE

If there are problems measuring your heart rate or if your heart rate is too high, the console will end the programme.

6. Press the START/PAUSE button to pause the training.
7. Press the START/PAUSE button again to continue the training.
8. Press the STOP button to end your training.

3.5 Wireless Connection and Fitness Apps

This console is equipped with a wireless interface. Please take note that your mobile device needs to be compatible with the wireless interface of the treadmill.

To use training apps you will have to activate the wireless connection function on your mobile device (tablet or smart phone) and start the fitness app. Select your fitness equipment. Please follow the instructions given in the app. You will find the name of your fitness equipment on a small sticker on the back of the console.

You will find the fitness apps in the app stores of Google or Apple. There you will find the apps "Kinomap" or "Zwift". Please note that these apps are produced by an external manufacturer. Fitshop does not take any responsibility regarding the availability, functionality or contents of these programmes.

IMPORTANT NOTE

The pre-installed apps are produced and provided by external manufacturers. Changes and availability within these apps might occur. Fitshop does not take any responsibility and can not be held liable for the availability, functionality or contents of these apps. To make sure the pre-installed apps are working correctly, they must be updated regularly. If needed, the respective app will notify you to do so. To update the app, you need a google account. A google email is sufficient. Just follow the instructions on the screen to perform the update.

Please note: The system is set up only for the pre-installed apps. Do not install any additional apps as their proper functionality can not be guaranteed. The installation of other apps might cause technical issues.

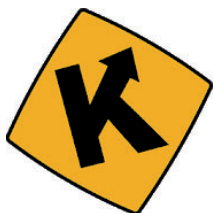
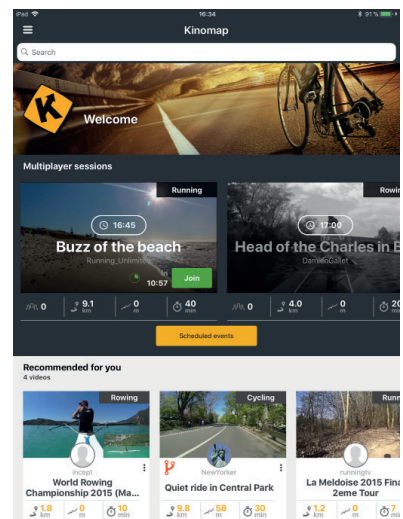
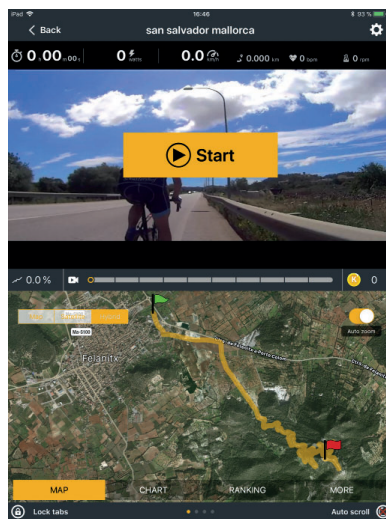
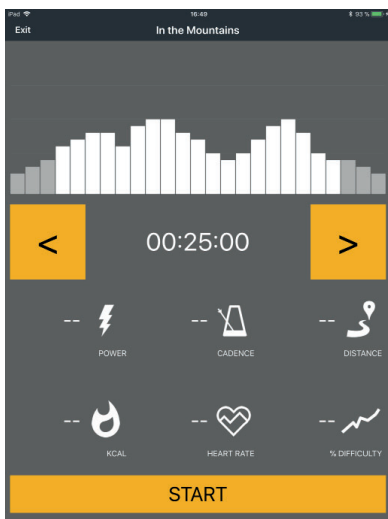

Example: Kinomap

4.1 General Instructions

WARNING

- + The storage location should be chosen so that improper use by third parties or children can be prevented.
- + If your equipment does not have transportation wheels, the equipment must be disassembled before transportation.

ATTENTION

- + Make sure that the equipment is protected from moisture, dust and dirt in the selected storage location. The storage location should be dry and well ventilated and have a constant ambient temperature between 10°C and 35°C.

4.2 Transportation Wheels

ATTENTION

If you want to transport your equipment over particularly sensitive and soft floor coverings, such as parquet, planks or laminate, lay out the transport route with cardboard or similar to avoid possible floor damage.

1. Stand behind the equipment and lift it until the weight is transferred to the transportation wheels. After that, you easily can move the equipment to a new position. For long transport distances the equipment should be disassembled and safely packed.
2. Select the new location by following the instructions in the section 1.4 of this manual.

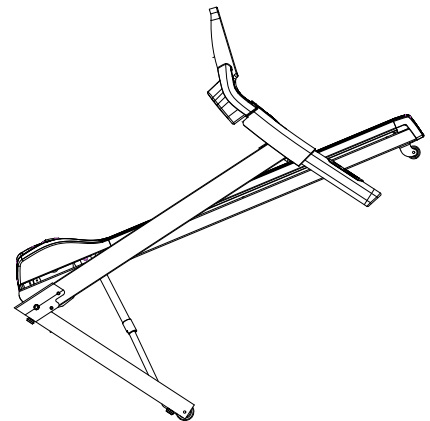

4.3 Folding Mechanism

WARNING

- + The treadmill is equipped with high-pressure shock absorbers that can cause the treadmill to suddenly open if handled incorrectly. For more information, refer to the section 2.1 of this manual.
- + Do not lift the treadmill by the running mat or the rear transporting wheels. These parts do not lock and are difficult to grab.

NOTICE

The treadmill is foldable and thus saves space when it is stored. It also makes it easier to transport.

4.3.1 Folding Up the Treadmill

⚠ WARNING

- + Do not connect the equipment to the power supply when it is folded up. Try not to operate the equipment when it is folded up.
- + The running surface must have come to a complete stop before folding.

⚠ CAUTION

- + Do not lean on the equipment when it is folded and do not place anything on top of it that may make the equipment unstable or fall down.

▶ ATTENTION

- + Make sure that nothing is standing next to or on top of the treadmill that can be spilled or thrown or that makes it impossible to fold the treadmill.

1. Turn off the on/off switch and remove the plug from the outlet.
2. Use both hands to grab the supportive bar directly under the rear part of the running mat so that you have a stable lifting point.
3. Make sure that the hydraulic brake is correctly locked and tilt the treadmill forward.
4. Make sure that you are standing safely and make sure that the locking mechanism is secure by pulling the equipment backwards and it does not move.



4.3.2 Unfolding the Treadmill

▶ ATTENTION

- + Make sure that nothing is standing next to or on top of the treadmill that can be spilled or thrown or that makes it impossible to unfold the treadmill.

1. Stand behind the treadmill and push the device slightly forward towards the display.
2. To release the hydraulic brake lock, use your left foot to push the upper part of the hydraulic brake slightly forward until the lock releases and the treadmill can be pulled back.
3. Keep holding the treadmill.

The hydraulic brake lowers itself gently downwards.

4. Once the treadmill has lowered $\frac{2}{3}$, you can let go of the treadmill.

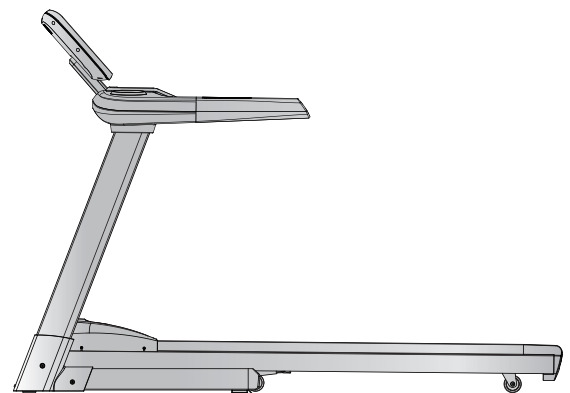

5.1 General Instructions



WARNING

- + Do not make any improper changes to the equipment.



CAUTION

- + Damaged or worn components may affect your safety and the life of the equipment. Therefore, immediately replace damaged or worn components. In such a case, contact the contract partner. The equipment must not be used until it has been repaired. If necessary, use only original spare parts.

ATTENTION

- + In addition to the instructions and recommendations for maintenance and care given here, additional service and/or repair work may be necessary; this must only be carried out by authorised service technicians.

5.2 Faults and Fault Diagnosis

The equipment undergoes regular quality controls during production. Nevertheless, faults or malfunctions may occur. Frequently, individual parts are responsible for these disturbances, an exchange is usually sufficient. Please refer to the following overview for the most common errors and how to correct them. If the equipment still does not function properly, contact your contract partner.

Fault	Cause	Solution
Console is not responding	Safety key missing or not inserted correctly	Check whether Safety Key is inserted and insert if necessary
Running mat slanting	Running mat not centered	Adjust the running mat according to the instructions
Grinding noises		
Running mat slips through/stops	Tape tension/lubrication not correct	Check belt tension/lubrication according to instructions
Display is blank/is not working	+ Interrupted power connection + Loose cable connections	+ Power switch to on + Check whether Safety Key is plugged in + Check cable connections
No pulse display	+ Sources of interference in the room + unsuitable chest strap + Wrong position of chest strap + Chest strap defective or battery empty + Pulse display defective	+ Eliminate sources of interference (e.g. mobile phone, WLAN, lawn mower and vacuum cleaner robot, etc. ...) + Use a suitable chest strap (see RECOMMENDED ACCESSORIES). + Reposition chest strap and/or moisten electrodes + Changing batteries + Check if pulse display by hand pulse possible

5.3 Care and Maintenance

The most important maintenance measure is the care of the running mat. This includes adjustment, re tensioning and lubrication of the running mat. Damage resulting from insufficient or neglected care is not covered by the warranty. You should therefore carry out maintenance checks at regular intervals. Be very careful when adjusting and tightening the running mat, as a strong over voltage or under voltage can cause damage to the equipment. The running mat is adjusted at the factory according to the regulations before delivery. However, it may happen that the running mat slips during transport.

By scanning the QR-code with the camera function or QR-code scanner app of your smartphone/tablet, a video on general maintenance of a treadmill opens on YouTube. The video serves to illustrate the maintenance points described in this manual.



Please note that the video may not be available in your language or with appropriate subtitles.

If you cannot scan QR-codes, you can access all Fitshop videos on YouTube by first opening YouTube and entering "Fitshop" in the search field.

5.3.1 Adjusting the Running Mat

During training, the running mat should run as centrally and straight as possible. The alignment of the running mat can change depending on the stress and load. Another reason can be the positioning of the equipment on an uneven surface.

CAUTION

During the following maintenance nobody must be on the treadmill!

1. Let the treadmill run at a speed of 5 km/h.
2. If the running mat deviates to the left, turn the left adjusting screw at the rear end of the device max. one $\frac{1}{4}$ turn clockwise and the right adjusting screw max. one $\frac{1}{4}$ turn anticlockwise.
3. If the running mat deviates to the right, turn the right adjusting screw at the rear end of the device max. $\frac{1}{4}$ turn clockwise and the left adjusting screw max. $\frac{1}{4}$ turn anticlockwise.
4. Then observe the mat for about 30 seconds, as the change is not immediately visible.
5. Repeat this procedure until the running mat is straight again. If the running mat cannot be adjusted, please contact your contract partner.

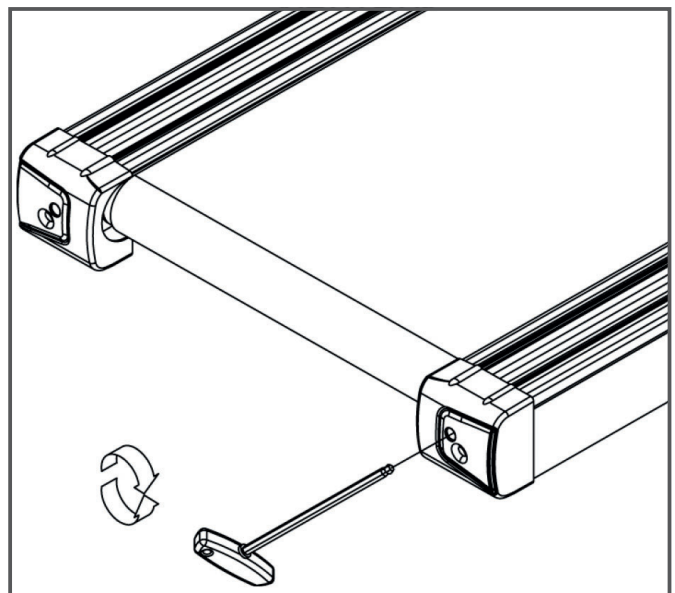

5.3.2 Re-tensioning the Running Mat

If the running mat slips over the rollers during operation (if this is the case, there is a noticeable jerk during running), the running mat must be re tightened.

In most cases, the slipping is caused by stretching of the mat through use. This is perfectly normal.

ⓘ NOTICE

Re-tensioning is carried out using the same adjusting screws that are used for adjustment.

1. Let the treadmill run at a speed of 5km/h.
2. Turn the left and right adjusting screws directly one after the other, max. one ¼ turn clockwise.
3. Then check whether the running mat continues to slip. If this is the case, you must perform the described procedure again.

5.3.3 Lubricating the Running Mat

If the running mat is not sufficiently lubricated, friction increases significantly and this leads to heavy wear of the endless belt, running plate, motor and circuit board. If you feel an increased friction of the running mat, this is an indication that you should lubricate the mat. However, lubrication should be carried out at least every 3 months or every 50 operating hours. Whichever case comes first.

ⓘ NOTICE

If your treadmill is equipped with a folding mechanism, you can also lubricate it when it is folded.

1. Raise the running mat slightly.
2. Apply some silicone oil or silicone spray to the entire deck and distribute evenly.
3. Continue turning the belt by hand so that the entire surface between the endless belt and the running plate is lubricated.
4. Wipe off the excess silicone oil or silicone spray.

ⓘ NOTICE

This maintenance must also be carried out after prolonged non-use of the equipment.

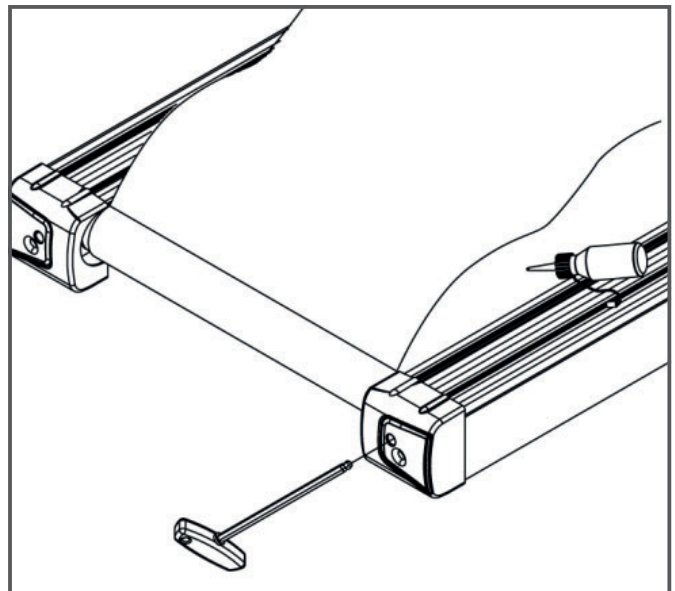

5.4 Maintenance and Inspection Calendar

To avoid damage from body sweat, the equipment must be cleaned with a damp towel (no solvents!) after each training session.

The following routine tasks must be performed at the specified intervals:

Part	Weekly	Monthly	Quarterly
Display console	C	I	
Tension of the running mat			I
Lubrication of the running mat			I
Plastic covers	C	I	
Screws and cable connections			I
Legend: C = clean; I = inspect			

By scanning the QR-code with the camera function or QR-code scanner app of your smartphone/tablet, a video on general maintenance of a treadmill opens on YouTube. The video serves to illustrate the maintenance points described in this manual.



Please note that the video may not be available in your language or with appropriate subtitles.

If you cannot scan QR-codes, you can access all Fitshop videos on YouTube by first opening YouTube and entering "Fitshop" in the search field.

6 DISPOSAL

At the end of its operational life, this equipment cannot be disposed of in normal household waste. Instead, it must be disposed of via an electricals recycling centre. Further information can be obtained from your local authority's recycling service.



The materials can be recycled as per their symbols. Through the reuse, recycling of materials or other forms of recovery of old equipment, you make an important contribution to the protection of the environment.

7 RECOMMENDED ACCESSORIES

To make your training experience even more efficient and pleasant, we recommend that you add suiting accessories to your fitness equipment. For treadmills this could for example be a **floor mat**, which makes your fitness equipment stand more securely and also protects the floor from sweat or **silicone spray** to keep moving parts in good shape and lubricate the running mat. Furthermore, there are additional **handrails** available for some treadmills.

If you have purchased a fitness machine with pulse training and want to train your heart rate, we strongly recommend that you use a compatible **chest strap**, as this ensures optimum transmission of the heart rate.

Our range of accessories offers the highest quality and makes training even better. If you would like to find out more about compatible accessories, please go to the detail page of the product in our webshop (the easiest way is to enter the article number in the search field above) and go to the recommended accessories on this page. Of course, you can also contact our customer service: by telephone, e-mail, in one of our branches or via our social media channels. We will be happy to advise you!



floor mat



chest strap



handrails



lubricant

8.1 Serial Number and Model Name

In order to provide you with the best possible service, please have the model name, article number, serial number, exploded drawing and parts list ready. The corresponding contact options can be found in chapter 10 of this operating manual.

NOTICE

The serial number of your equipment is unique. It's located on a white sticker. The exact position of this sticker is shown in the following illustration.

Enter the serial number in the appropriate field.

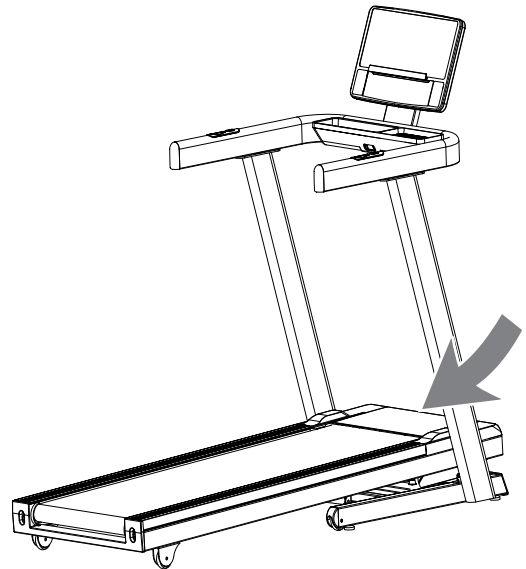

Serial number:

Brand / Category:

Model Name:

SKU:

8.2 Parts List

No.	Name	Specification	Qty.
1	Base weldment		1
2	"Hexagon large flat head half-tooth bolt"	M8×50×20	2
3	hexagon lock nut	M8	2
4	flat washer	Φ8	2
5	"Tapered foot pad (OMA-05-07-005)"	Φ50×Φ41×17×M8×27	4
6	wheel	Φ62×Φ8.0×t22	2
7	Curved open pipe plug	40×60×t2.0	2
8	frame weldment		1
9	"Motor mount(1320CA-06)"		1
10	"motor cover plate"		1
11	fixed tube of motor cover	Φ16×t1.2×23	1
12	Hexagon cylindrical head full tooth bolt	M8×75	1
13	Hexagon cylindrical head full tooth bolt	M8×60	2
14	Hexagon cylindrical head full tooth bolt	M8×15	2
15	Hexagon large flat head full tooth bolt	M8×15	1
16	Hexagon large flat head half- tooth bolt	M8×45×20	2
17	"Hexagon countersunk head full tooth bolt"	M6×30×Φ16	4
18	"Cross recessed large flat head full tooth bolt"	M5×10	2
19	Cross recessed large flat head full tooth bolt	M4×10	6
20	"Cross recessed large flat head tapping screw"	ST4×16	4
21	Cross recessed large flat head tapping screw	ST4×10	7
22	"Cross recessed pan head tapping screw"	ST3×10	4
23	"Cross recessed countersunk head tapping screw"	ST4×15	2
24	console frame welds		1
25	spring washer	Φ8	3
26	spring washer	Φ5	17
27	"serrated lock washers external teeth"	Φ5	2
28	flat washer	Φ8	3
29	hex lock nut	M8	3

30	"Hexagon large flat head half-tooth bolt"	M10×35×20	3
31	"Hexagon large flat head half- tooth bolt"	M10×65×20	2
32	hexagon lock nut	M10	1
33	flat washer	Φ10	1
34	flat washer	Φ8	1
35	communication line	"SM5PIN/SM4PIN/L-750mm/26#"	1
36	photoelectric sensor	L-500	2
37	"3330EAcontroller (ERP)"	1-20KM/H/incline(ERP)	1
38	power connection cable	L-300mm/1.5mm2/(red)	1
39	power connection cable	"L-300mm/1.5mm2/(black)"	1
40	rocker switch	KCD4	1
41	Self-resetting switch	"10A/ABR21-16/250VAC"	1
42	power connection cable	L-100mm/1.5mm2/(red)	1
43	power plug	3×1.0mm2×2000	1
44	3330EA front roller	Φ88×Φ50×Φ17×606	1
45	3330EA rear roller	Φ50×Φ17×529×578	1
46	motor	Φ32/36	1
47	incline motor	(195mm)	1
48	3330EA running deck	1300×604×t18	1
49	running belt	2930×500×t1.6	1
50	motor belt	PJ6	1
51	3330EA motor cover		1
52	rear cover	673×93×51	1
53	side rail	87×34.5×1342	1
54	wheel	Φ62×Φ8.0×t22	1
55	cushion		2
56	Round guide block	Φ25×φ5×4.5	2
57	pipe strap	Φ16 (white)	6
58	EVA pad	t15×30×30	10
59	magnet ring		3
60	cable clip		1
61	power cable clip		1
62	upright post L welds		1
63	upright post R welds	0.32 m ²	1

64	communication line	SM4PIN/SM4PIN/L- 1200mm/26#	1
65	Lift frame welds		1
66	"Hexagon head half-tooth bolt"	M12×Φ14×35×19	2
67	"Hexagon large flat head full tooth bolt"	M10×25×15	2
68	"Powder metallurgy sleeve"	Φ24×Φ19×Φ14×14×3	2
69	Sleeve	Φ25×Φ18×t3.0	2
70	flat washer	Φ14	2
71	"Lifting shaft sleeve(OMA-05-06-023)"	Φ25×Φ17×Φ10×6×1	4
72	"console fixed welds"		1
73	speaker grille	t0.5×66×90/1260×3000	2
74	Cross recessed large flat head tapping screw	ST4×16	12
75	Cross recessed countersunk head tapping screw	ST4×15	4
76	Cross recessed countersunk head tapping screw	ST4×65	2
77	Cross recessed countersunk head tapping screw	ST3×10	2
78	Cross recessed large flat head tapping screw	ST4×10	2
79	panel	6710EA/479×294×22	1
80	Panel rear cover	3305EB/479×294×50	1
81	console basket	3330EA/741×270×72.5	1
82	PC plate	357×44.5×t0.5	1
83	cup	1950CA/Φ100×118	1
84	"speed hand-held heartbeat components"	"7239EA/SM5PIN/L-50MM/SPEED+/-"	1
85	incline hand- held heartbeat components	"7239EA/L-50MM/SM5PIN/INCLINE+/-"	1
86	communication line	"SM4PIN/SM4PIN/L-750mm/26#"	1
87	"3337EA console set"	3LED/1-20KM/H/0-15%	1
88	"hand-held heartbeat cable"	3330EA/L-1000mm	1
89	Safety clamp	J52×15×15/L-700	1
90	Safety lock socket	J86×20×16	1
91	IPAD tray	5130/300×25×20	1
92	D-shaped tube plug	DX40×80	2
93	ezfit linking	Φ29×t1.2×340	1

94	"Hexagon large flat head half- tooth bolt"	M8×50×20	1
95	"Hexagon large flat head half-tooth bolt"	M8×30×20	1
96	"Double round tube plug"	Φ33×Φ23×48	1
97	hex lock nut	M8	2
98	flat washer	Φ88×Φ50×Φ17×606	2
99	"gas spring (OMA-01-03-039)"	720×318×Φ10×Φ8.2×350N	1
100	shrapnel-1	t0.6×16.5×43	1
101	acrylic of display board		1
102	keyboard cover		1
103	"Hexagon large flat head half-tooth bolt"	M8×50×20	4
104	Hexagon large flat head full tooth bolt	M8×15	8
105	"Hexagon pan head full tooth bolt"	M6×10	4

8.3 Exploded Drawing

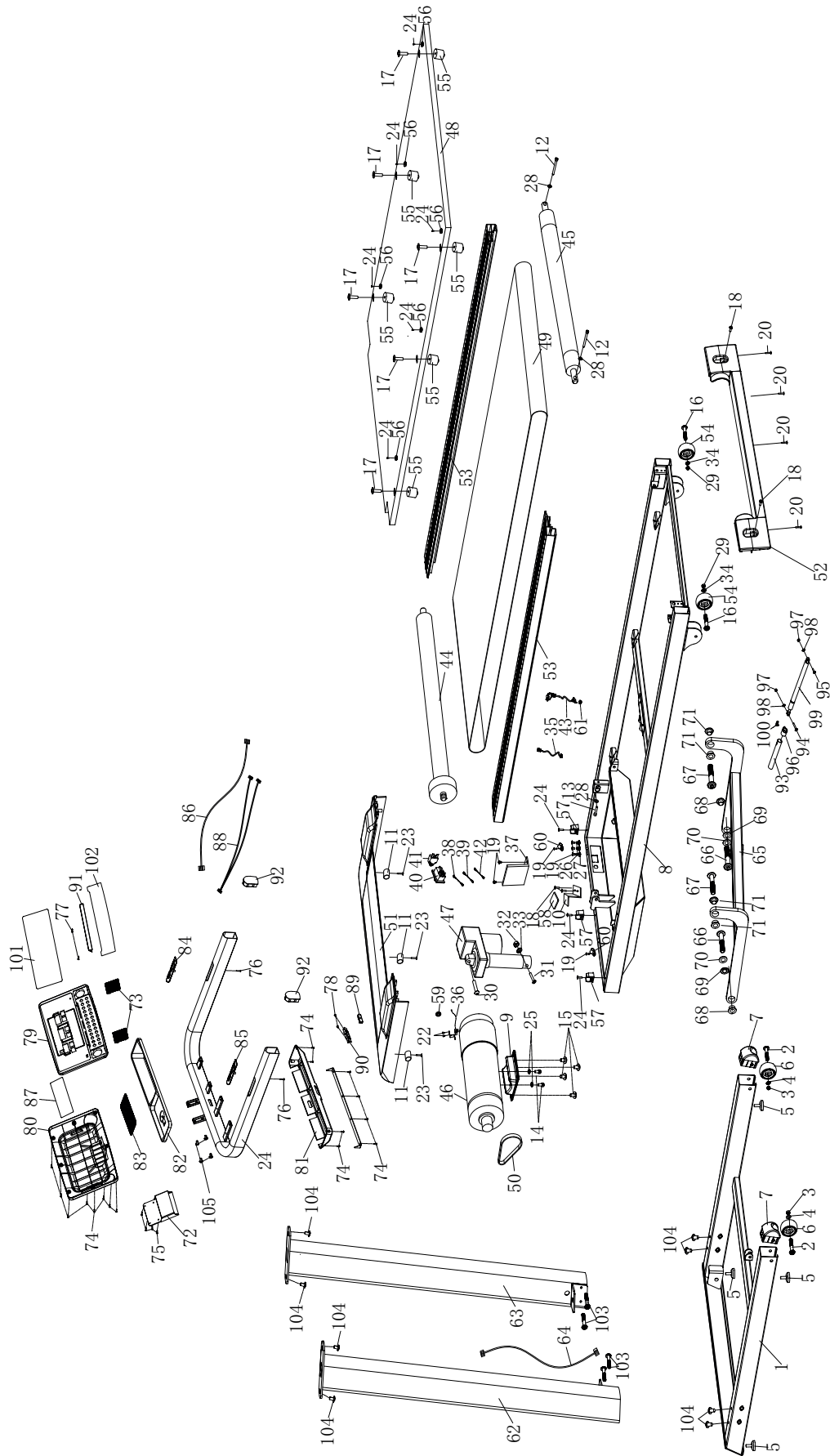

Products from BodyMax® are subject to strict quality control. However, if a fitness equipment purchased from us does not work perfectly, we take it very seriously and ask you to contact our customer service as indicated. We are happy to help you by phone via our service hotline.

Error Descriptions

Your fitness equipment is developed for long-term, high-quality training. However, should a problem arise, please first read the operating instructions. For further assistance, please contact your contract partner or call our service hotline. To ensure your problem is solved as quickly as possible, please describe the defect as exactly as possible.

In addition to the statutory warranty, we provide a warranty for every fitness equipment purchased from us according to the following provisions.

Your statutory rights are not affected.

Warranty

The warranty is the first/original buyer.

Warranty periods

The following warranty periods begin on delivery of the fitness equipment.

Warranty period

The warranty periods, shown on our web shop, begin on delivery of the fitness equipment. The respective warranty periods for your equipment can be found on its product website.

Repair Costs

According to our choice, there will either be a repair, a replacement of individual damaged parts or a complete replacement. Spare parts, that have to be mounted while assembling the equipment, have to be replaced by the warranty holder personally and are not a part of repair. After the expiration of the warranty period, the responsibility for parts costs, repair costs, installation costs and delivery costs lies with the warranty holder.

The terms of use are defined as follows:

- + Home use: solely for private use in private households up to 3 hours per day
- + Semi-professional use: up to 6 hours per day (e. g. rehabilitation centres, hotels, clubs, company gyms)
- + Professional use: more than 6 hours per day (e. g. commercial gyms)

Warranty Service

Within the warranty period, equipment which develops faults as a result of material or manufacturing defects, will be repaired or replaced at our discretion. Ownership of equipment or parts of equipment which have been replaced is transferred to us. The warranty period is not extended nor does a new warranty period begin following repair or replacement under the warranty.

Warranty Conditions

For the warranty to be valid, the following steps must be taken:

Please contact our customer service by email or phone. If the product under warranty has to be sent in for repair, the seller bears costs. After expiry of the warranty, the buyer bears the costs of transport and insurance. If the fault is covered by our warranty, you will receive a new or repaired equipment in return.

Warranty claims are invalid in case of damage resulting from:

- + misuse or improper handling
- + environmental influences (moisture, heat, electrical surge, dust, etc.)
- + failure to follow the current safety measures for the equipment
- + failure to follow the operating instructions
- + use of force (e. g. hitting, kicking, falling)
- + interventions which were not carried out by one of our authorized service centres
- + unauthorised repair attempts

Proof of Purchase and Serial Number

Please make sure that you are able to provide the appropriate receipt when claiming on your warranty. So that we can clearly identify the model of your equipment, and for the purposes of our quality control, you will need to give the serial number of your equipment, when contacting the service team. Where possible please have your serial number and your customer number ready when you call our service hotline. It will help us to deal with your request swiftly.

If you cannot find the serial number on your fitness equipment, our service team is at your disposal to offer further information.

Service outside of the Warranty Period

We are also happy to issue an individual cost estimate if there is a problem with your fitness equipment after the warranty has expired, or in cases which do not fall under the terms of the warranty, e. g. normal wear and tear. Please contact our customer service team to find a quick and cost-effective solution to your problem. In such a case you will be responsible for the delivery costs.

Communication

Many problems can be solved just by speaking to us as your specialist supplier. We know how important it is to you as a user of the fitness equipment to have problems solved quickly and simply, so you can enjoy working out with minimal interruption. For that reason, we also want to resolve your queries quickly and in a straightforward manner. Thus, please always keep your customer number and the serial number of the faulty equipment handy.

10 CONTACT

DE	DK	UK
<p>TECHNIK</p> <p>☎ +49 4621 4210-900 ☎ +49 4621 4210-698 ✉ technik@fitshop.de 🕒 Öffnungszeiten entnehmen Sie unserer Homepage.</p> <p>SERVICE</p> <p>☎ 0800 20 20277 (kostenlos) ☎ 04621 4210 - 0 ✉ info@fitshop.de 🕒 Öffnungszeiten entnehmen Sie unserer Homepage: https://stg.fit/statita</p>	<p>TEKNIK OG SERVICE</p> <p>☎ 80 90 16 50 +49 4621 4210-945 ✉ info@fitshop.dk 🕒 Åbningstider kan findes på hjemmesiden: https://stg.fit/statit7</p>	<p>CUSTOMER CARE</p> <p>☎ +44 141 737 2249 or +44 141 876 3972 ✉ customercare@fitshop.co.uk 🕒 You can find the opening hours on our homepage: https://stg.fit/statitd</p>
	FR	BE
	<p>TECHNIQUE & SERVICE</p> <p>☎ +33 (0) 189 530984 +49 4621 42 10 933 ✉ info@fitshop.fr 🕒 Vous trouverez les heures d'ouverture sur notre site Internet: https://stg.fit/statit4</p>	<p>TECHNIQUE & SERVICE</p> <p>☎ 02 732 46 77 +49 4621 4210 933 ✉ info@fitshop.be 🕒 Vous trouverez les heures d'ouverture sur notre site Internet: https://stg.fit/statit8</p>
ES	NL	INT
<p>TECNOLOGÍA Y SERVICIOS</p> <p>☎ 911 238 029 ✉ info@fitshop.es 🕒 Consulta nuestro horario de apertura en la página web: https://stg.fit/statit5</p>	<p>TECHNISCHE DIENST & SERVICE</p> <p>☎ +31 172 619961 ✉ service@fitshop.nl 🕒 De openingstijden vindt u op onze homepage: https://stg.fit/statit3</p>	<p>TECHNICAL SUPPORT & SERVICE</p> <p>☎ +49 4621 4210-944 ✉ service-int@fitshop.de 🕒 You can find the opening hours on our homepage: https://stg.fit/statita</p>
PL	AT	CH
<p>DZIAŁ TECHNICZNY I SERWIS</p> <p>☎ 22 307 43 21 +49 4621 42 10-948 ✉ info@fitshop.pl 🕒 Godziny otwarcia można znaleźć na stronie głównej: https://stg.fit/statit6</p>	<p>TECHNIK & SERVICE</p> <p>☎ 0800 20 20277 (Freecall) +49 4621 42 10-0 ✉ info@fitshop.at 🕒 Öffnungszeiten entnehmen Sie unserer Homepage: https://stg.fit/statitb</p>	<p>TECHNIK & SERVICE</p> <p>☎ 0800 202 027 +49 4621 42 10-0 ✉ info@fitshop.ch 🕒 Öffnungszeiten entnehmen Sie unserer Homepage: https://stg.fit/statit9</p>

Please find a detailed overview including address and opening hours for all stores of Fitshop UK on the following website:

www.fitshop.co.uk/storelocator

WE LIVE FITNESS

WEBSHOP AND SOCIAL MEDIA

The Fitshop Group is Europe's largest specialist for home fitness equipment with currently 70 stores and one of the world's most renowned online mail order companies for fitness equipment.

Fitshop UK is part of the Fitshop Group. Private customers order via the 25 web shops in the respective national language or have their desired equipment assembled on site. In addition, the company supplies fitness studios, hotels, sports clubs, companies and physio practices with professional equipment for endurance and strength training.

The Fitshop group offers a wide range of fitness equipment from renowned manufacturers, high-quality in-house developments and comprehensive services, such as a build-up service and sports scientific advice before and after the purchase. The company employs numerous sports scientists, fitness trainers and competitive athletes.

Visit us also on our social media platforms or our blog!



<https://www.fitshop.co.uk>
www.fitshop.co.uk/blog



www.facebook.com/fitshop.co.uk



www.instagram.com/fitshop_uk



www.youtube.com/@fitshop_uk

TAURUS

 cardiostrong

BODYCRAFT

BodyMax

Notes

BodyMax