

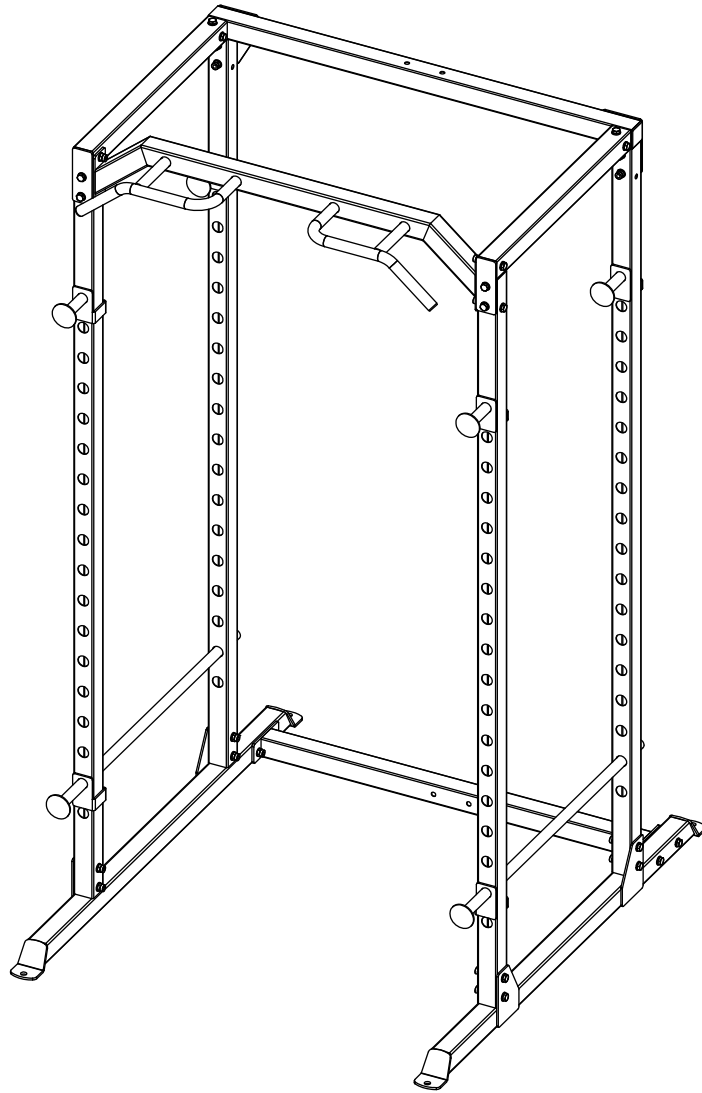

# BodyMax

## CF385+ Power Rack

SEBR2702



### ASSEMBLY INSTRUCTIONS

# SAFETY PRECAUTION

## Safety First

Regardless of how enthusiastic you may be about getting on your equipment and exercising, take the time to ensure that your safety is not jeopardized. A moment's lack of attention can result in an accident, as can failure to observe certain simple safety precautions.

1. Assemble the equipment according to the assembly instructions and only use the individual parts enclosed for assembly of the equipment and which are listed in the parts list as being specifically for this equipment. Before you start assembly, check against the delivery to make sure that everything has been delivered and check against the packing list to make sure all parts have been enclosed.
2. Read, study and understand the Owner's Manual and all the warning labels on this product. Furthermore, it is recommended to familiarize yourself and others with the proper operation and workout recommendations for this product prior to use. Some of this information can be obtained in this owner's Manual, as well as from your local retailer.
3. It is imperative that you retain this Owner's Manual and be sure all warning labels are legible and intact. Replacements Owner's Manual and labels are available from your local retailer.
4. It is recommended that another person assist you with the assembly of this unit.
5. Consult with your physician before beginning any exercise program. It is recommended that you undergo a complete physical examination.
6. Use proper discretion when children are present.
7. Frayed or worn cables can be dangerous and may cause injury. Periodically check these cables for any indication of wear.
8. Keep hands, limbs, loose clothing and long hair well out of the way of moving parts.
9. Do not attempt to lift more weight than you can control safely.
10. Work within your recommended exercise level. DO NOT work to exhaustion. If you feel any pain or discomfort, stop your workout immediately.
11. Inspect the machine for any sign of wear on parts, hardware becoming loose or cracks on welds. If a problem is found do not use or allow the machine to be used until the defective part is repaired or replaced.
12. DO NOT place any sharp objects around the machine.

# ASSEMBLY INSTRUCTION

## I . Notice of assembly

- \* An enough dimension will be required to assemble and properly use the machine.
- \* Please use floor padding, such as cardboard, to avoid scratching your floor during assembly.
- \* The nuts and bolts have a little grease on them to protect them from corrosion. Please keep a rag handy to wipe your hands.
- \* All plastic end caps and plugs have been assembled on the unit prior to shipment. They are shown on the assembly drawings for reference in the event replacement parts are needed.
- \* The machine uses several different lengths of bolts. Be careful to use the correct length of bolt called for at each step of assembly.
- \* Do not touch the wires and cables attention when drilling.

## II . Before you begin

Locate a comfortable work site. Assemble your machine in an open space with ventilation and lighting, and with the help of other person. The machine posses a large area, so you do not place it in living room.

Find your tools. You will need the following tools to assemble your machine.

- . Standard screwdriver
- . WD40 lubricant or Vaseline (if necessary)

Review all safety guideline on Page 2 of this manual.

## III . Assembling your machine

## PART LIST

<b>NUMBER</b>	<b>DESCRIPTION</b>	<b>QUANTITY</b>
1	Vertical Frame	4
2	Left Base Frame	1
3	Right Base Frame	1
4	Cross Brace	1
5	Upper Frame	1
6	Top Beam	2
7	Chin Up Bar	1
8	Left Handle	1
9	Right Handle	1
10	Left Safety Catch	1
11	Right Safety Catch	1
12	Left Adjustment Bar	2
13	Right Adjustment Bar	2
14	Bolt M10*16	6
15	Bolt M10*20	4
16	Bolt M10*70	24
17	Big Washer 10	58
18	Lock Nut M10	24
19	Round Plug	4
20	Square Plug	2

# Exploded View

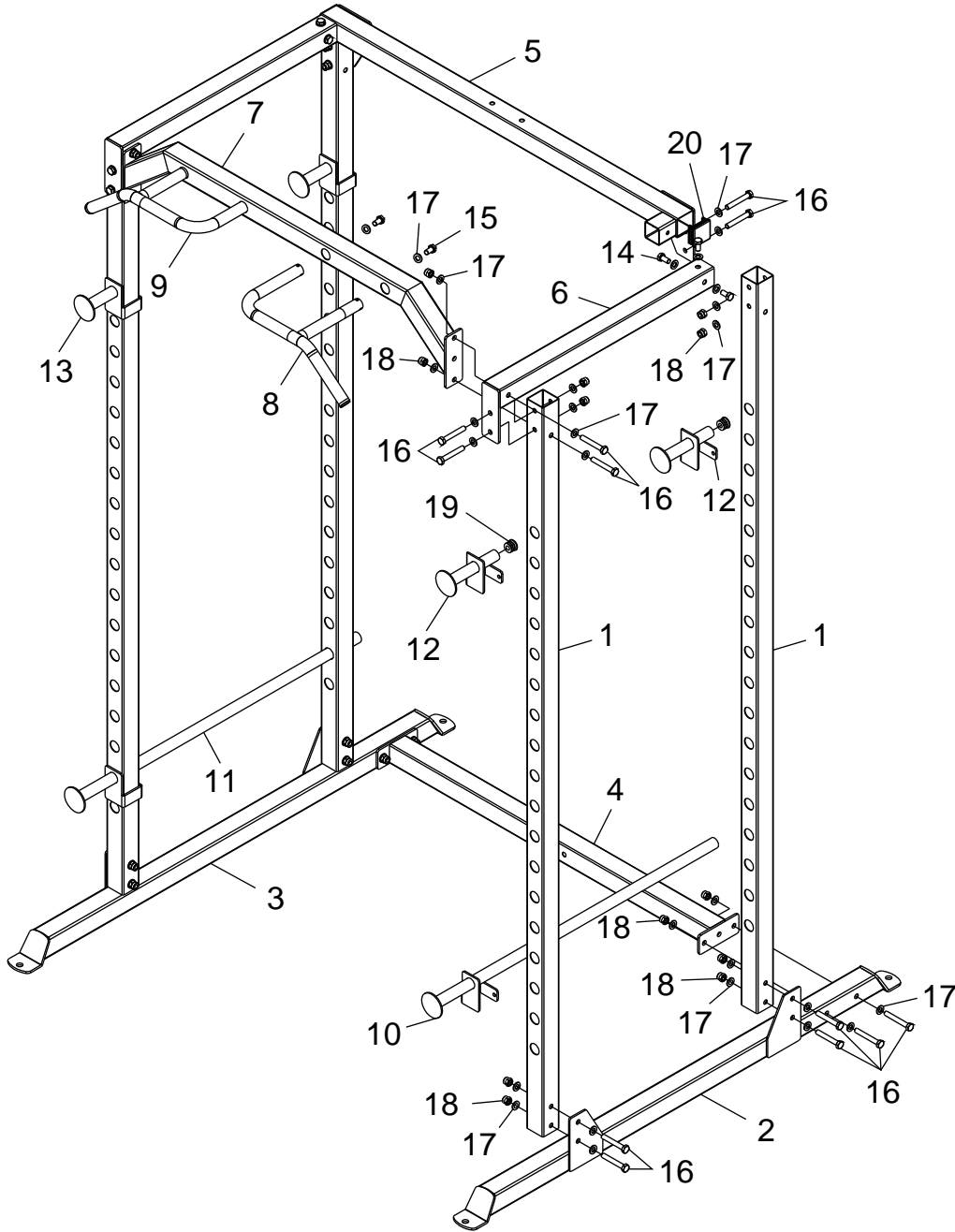

# ASSEMBLY STEPS

## STEP 01

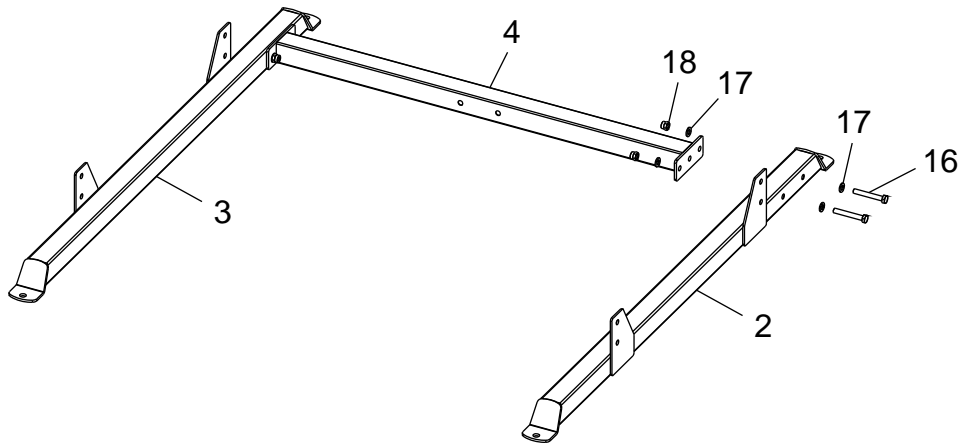

1. Attach Cross Brace (4) to Left & Right Base Frame (2&3) with four Bolts M10\*70 (16), eight Big Washers 10 (17) and four Lock Nuts M10 (18).

## STEP 02

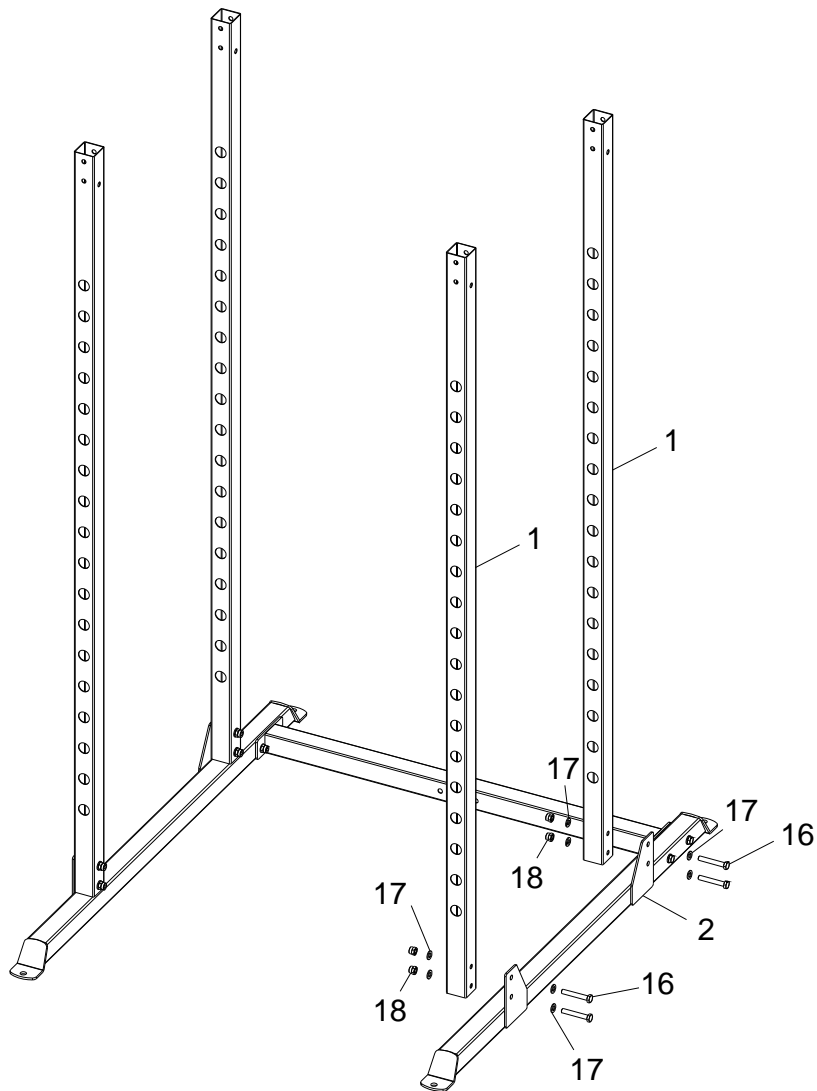

1. Attach four Vertical Frames (1) to Left & Right Base Frame (2&3) with eight Bolts M10\*70 (16), sixteen Big Washers 10 (17) and eight Lock Nuts M10 (18).

## STEP 03

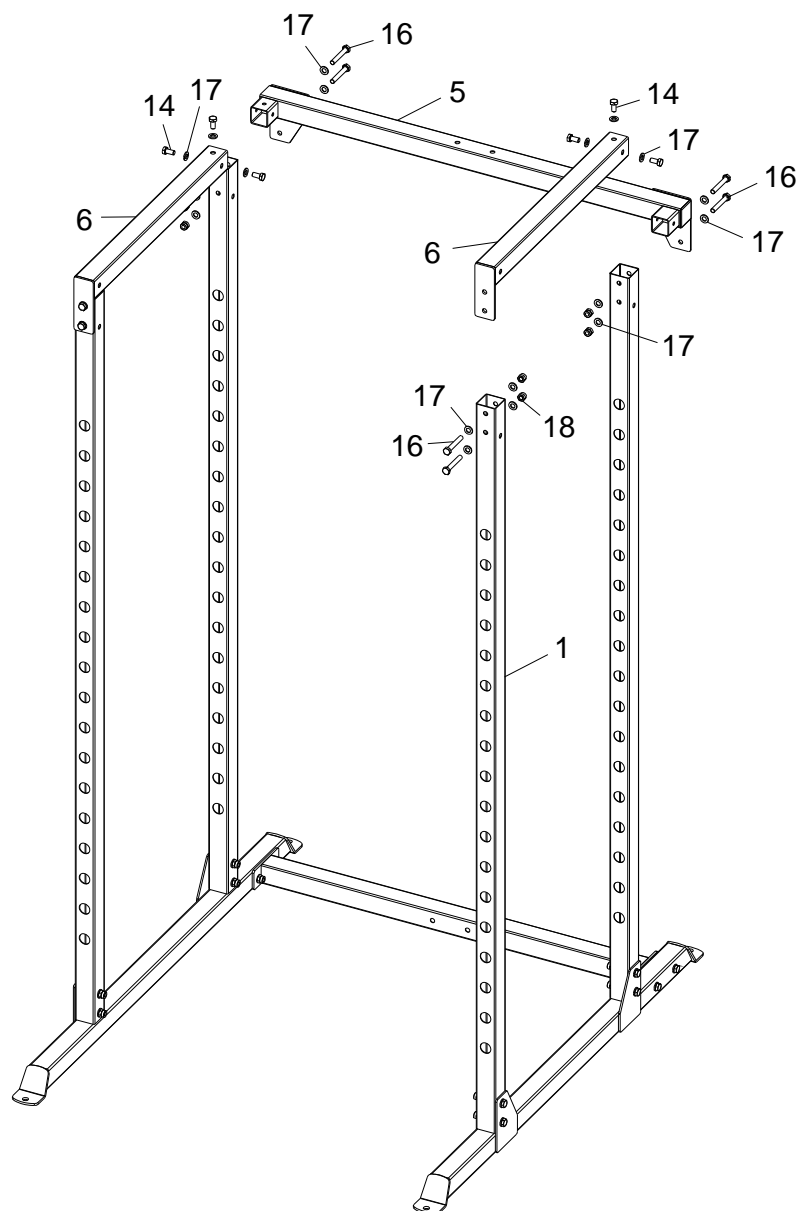

1. Attach Upper Frame (5) to Vertical Frame (1) with four Bolts M10\*70 (16), eight Big Washers 10 (17) and four Lock Nuts M10 (18).
2. Attach Top Beam (6) to Upper Frame (5) with six Bolts M10\*16 (14) and six Big Washers 10 (17),
3. Attach two Top Beam (6) to Vertical Frame (1) with four Bolts M10\*70 (16), eight Big Washers 10 (17) and four Lock Nuts M10 (18).



## STEP 04

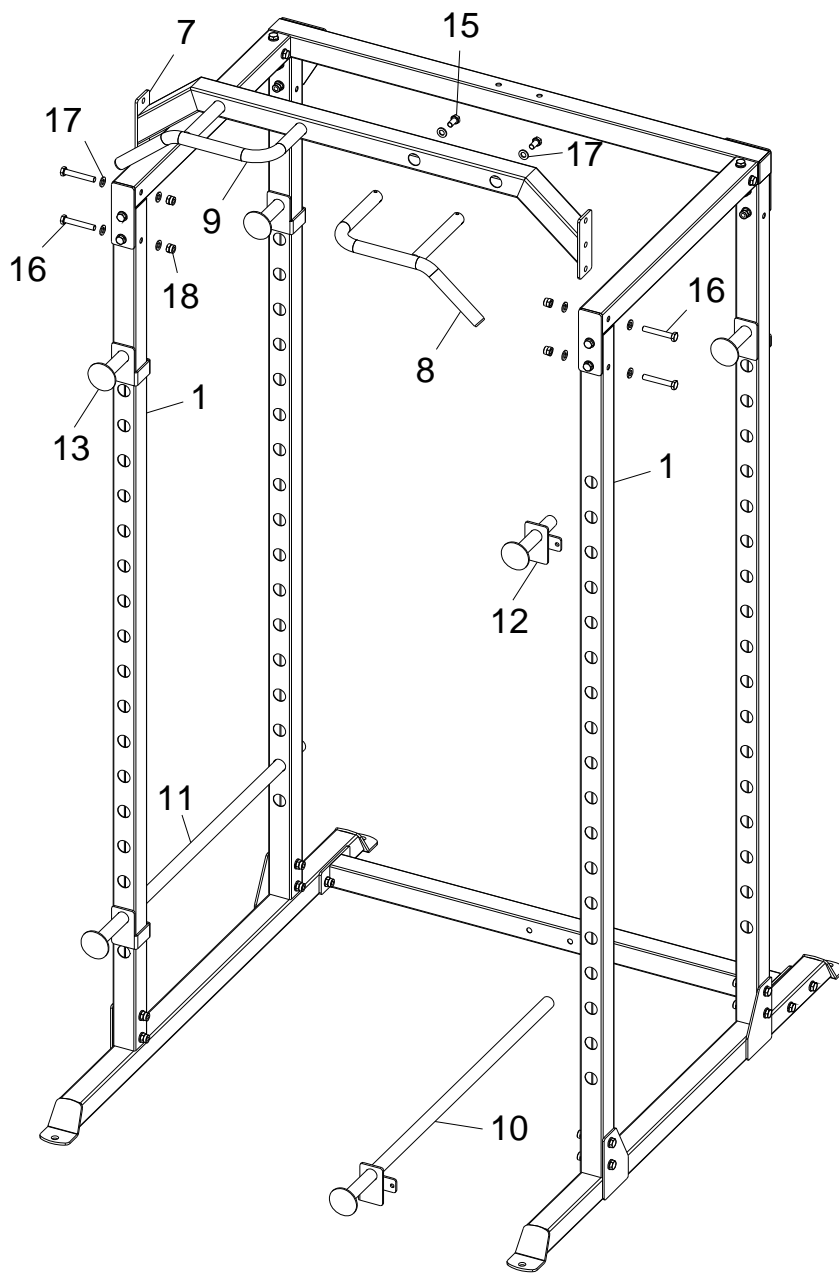

1. Attach Left & Right Handle (8&9) to Chin Up Bar (7) with four Bolts M10\*20 (15) and four Big Washers 10 (17).
2. Attach Chin Up Bar (7) to Vertical Frame (1) with four Bolts M10\*70 (16), eight Big Washers 10 (17) and four Lock Nuts M10 (18).
3. Insert Left & Right Safety Catch (10&11) and Left & Right Adjustment Bar (12&13) into Vertical Frame (1).