

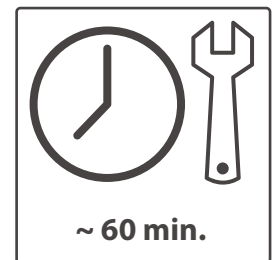

BodyMaxTM

PERFORMANCE WITHOUT COMPROMISE

Assembly and operating instructions

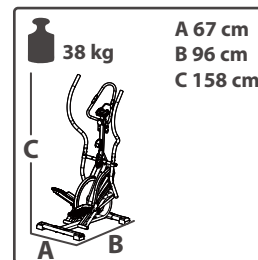
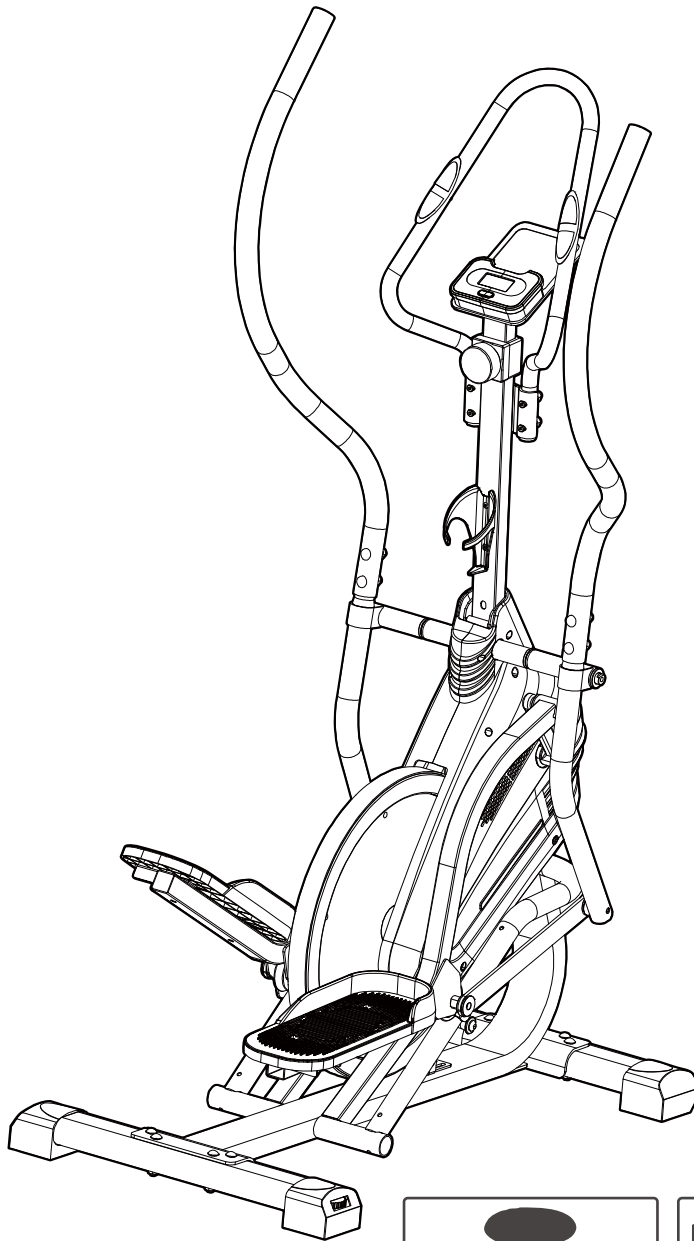

2021.05

Dear Customer,

Thank you for deciding for a high-quality training equipment of the brand BodyMax, the brand that makes athlete's hearts beat faster. BodyMax offers a wide range of home fitness equipment that is the optimal equipment for all those who want to train at home independent of goals and fitness level. For further information please visit www.powerhouse-fitness.co.uk or www.bodymax-fitness.com.

SAFETY NOTICE



Please read all of the instructions carefully before assembly and first use. These instructions are intended to ensure speedy assembly and explain safe usage. Make sure that all people exercising with the equipment (in particular children and persons with limited physical, sensory, mental or motor capabilities) are informed about these instructions and its content in advance. In case of doubt, a responsible person must supervise the use of the equipment.

This equipment has been manufactured according to the latest safety knowledge. As far as possible, potential safety hazards which could cause injury have been eliminated. Make sure to follow the instructions carefully and that all parts are securely in place. If required, read through the instructions again to correct any mistakes.

Please pay close attention to the safety and maintenance instructions given here. The contract partner cannot be held liable for damage to health, accidents or damage to the equipment when it is not used in accordance with these instructions.

The equipment is only suitable for use at home. The equipment is not suitable for semiprofessional (e. g., hospitals, clubs, hotels, schools, etc.) and commercial or professional use (e. g., health clubs).

Retain these instructions in a safe place for future reference, maintenance or when ordering replacement parts.

CONTENTS

1	IMPORTANT SAFETY NOTICE	5
2	GENERAL INFORMATION	6
2.1	Technical data	6
2.2	Personal safety	7
2.3	Set-up place	8
3	ASSEMBLY INSTRUCTION	9
3.1	General instructions	9
3.2	Scope of Delivery	10
3.3	Assembly	12
4	OPERATING INSTRUCTIONS	18
4.1	Console Display	18
4.2	Functions Button	18
5	STORAGE AND TRANSPORT	19
5.1	General Instructions	19
5.2	Folding Mechanism	19
6	TROUBLESHOOTING, CARE AND MAINTENANCE	20
6.1	General Instructions	20
6.2	Faults and Fault Diagnosis	20
6.3	Maintenance and Inspection Calendar	20
7	DISPOSAL	21
8	RECOMMENDED ACCESSORIES	21
9	ORDERING SPARE PARTS	22
9.1	Serial Number and Model Name	22
9.2	Parts list	23
9.3	Exploded drawing	24
10	WARRANTY	25
11	CONTACT	27

ABOUT THIS MANUAL

Please carefully read the entire manual before installation and first use. The manual will help you to quickly set up the system and explains how to safely use it. Make sure that all persons exercising with the equipment (especially children and persons with physical, sensory, mental or motor disabilities) are informed about this manual and its contents in advance. In case of doubt, responsible persons must supervise the use of the equipment.

This equipment has been manufactured according to the latest safety knowledge. As far as possible, potential safety hazards which could cause injury have been eliminated. Make sure to carefully follow the instructions and that all parts are securely in place. If required, read through the instructions again to correct any mistakes.

Please pay close attention to the safety and maintenance instructions given here. The contract partner cannot be held liable for damage to health, accidents or damage to the equipment when it is not used in accordance with these instructions.

The following safety instructions may appear in this manual:

► ATTENTION

This notice indicates potentially hazardous situations which, if not avoided, may result in property damage.

⚠ CAUTION

This notice indicates potentially hazardous situations which, if not avoided, may result in slight or minor injuries!

⚠ WARNING

This notice indicates potentially hazardous situations which, if not avoided, may result in death or serious injuries!

⚠ DANGER

This notice indicates potentially hazardous situations which, if not avoided, will result in death or serious injuries!

ⓘ NOTICE

This notice indicates further useful information.

Retain these instructions in a safe place for future reference, maintenance or when ordering replacement parts.

2.1 Technical data

LCD Display of

- + Speed in km/h
- + MPH
- + Training Time in min
- + Training Distance
- + Calories Burnt
- + Heart Rate

Resistance system:	manual magnetic brake system
Resistance level:	8
Maximum stride length:	25.4 cm
Stride height:	18 cm
Stride width:	27 cm
Flywheel mass:	7 kg

Weight and Dimensions:

Article weight (gross, incl. packaging) approx.:	42 kg
Article weight (net, without packaging) approx.:	38 kg
Packaging dimensions (L x W x H) approx.:	93.5 cm x 33 cm x 77.5 cm
Set up dimensions (L x W x H) approx.:	95.5 cm x 67.3 cm x 158 cm
Maximum user weight:	120 kg

2.2 Personal safety

DANGER

- + Before you start using the equipment, you should consult your physician that this type of exercise is suitable for you from a health perspective. Particularly affected are persons who: have a hereditary disposition to high blood pressure or heart disease, are over the age of 45, smoke, have high cholesterol values, are overweight and/or have not exercised regularly in the past year. If you are under medical treatment that affects your heart rate, medical advice is absolutely essential.
- + Note that excessive training can seriously endanger your health. Please also note that heart rate monitoring systems can be inaccurate. If you notice any signs of weakness, nausea, dizziness, pain, shortness of breath, or other abnormal symptoms, stop exercising immediately and seek advice from your doctor if necessary.

WARNING

- + This equipment may not be used by children under the age of 14.
- + Children should not be allowed unsupervised access to the equipment.
- + Persons with disabilities must have a medical license and must be under strict observation when using the equipment.
- + The equipment is strictly for use by one person at a time.
- + If your equipment provides a safety key, the clip of the safety key must be attached to your clothing before starting your training. In the event of a fall, the EMERGENCY STOP of the equipment can be initiated.
- + Keep your hands, feet and other body parts, hair, clothing, jewellery and other objects well clear of moving parts.
- + During use, wear suitable sports clothing rather than loose or baggy clothing. When wearing sports shoes, make sure they have suitable soles, preferably made of rubber or other non-slip materials. Shoes with heels, leather soles, studs or spikes are unsuitable. Never exercise barefoot.

CAUTION

- + If your equipment needs to be connected to the power supply with a mains cable, make sure that the cable is not a potential tripping hazard.
- + Make sure that nobody is within the range of motion of the equipment during training so as not to endanger you or other persons.

ATTENTION

- + Do not insert any objects of any kind into the openings of the device.

2.3 Set-up place

**WARNING**

- + Do not place the equipment in main corridors or escape routes.

**CAUTION**

- + Choose a location in which to place the equipment such that there is enough free space/ clearance to the front, the rear and to the sides of the equipment.
- + The training room should be well ventilated during training and not be exposed to any draughts.
- + Choose the place in which to set up the equipment such that there is enough free space/ clearance to the front, the rear and to the sides of the equipment.
- + The set-up and mounting surface of the equipment should be flat, loadable and solid.

**ATTENTION**

- + The device may only be used in one building, in sufficiently tempered and dry rooms (ambient temperatures between 10°C and 35°C). The equipment should not be used outdoors or in rooms with high humidity (over 70%) like swimming pools.
- + A floor protective mat/equipment underlay can help to protect high-quality floor coverings (parquet, laminate, cork, carpets) from dents and sweat and can help to level out slight unevenness.

3.1 General instructions

 **DANGER**

- + Do not leave any tools, packaging materials such as foils or small parts lying around, as otherwise there is a danger of suffocation for children. Keep children away from the equipment during assembly.

 **WARNING**

- + Pay attention to the instructions attached to the equipment in order to reduce the risk of injuries.

 **CAUTION**

- + Ensure to have sufficient room for movement in each direction during assembly.
- + The assembly of the equipment must be carried out by at least two adults. If in doubt, seek the help of a third technically skilled person.

 **ATTENTION**

- + To prevent damage to the equipment and the floor, assemble the equipment on a mat or packaging board.







 **NOTICE**

- + In order to make the assembly as simple as possible, some screws and nuts to be used can already be pre-assembled.
- + Ideally, assemble the equipment at its later set-up place.

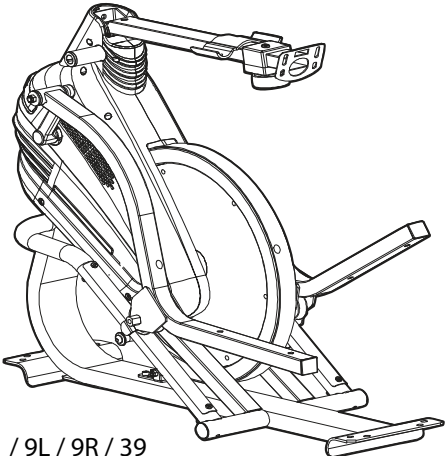
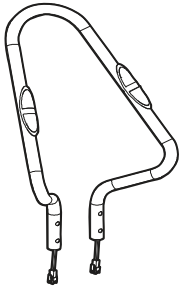
3.2 Scope of Delivery

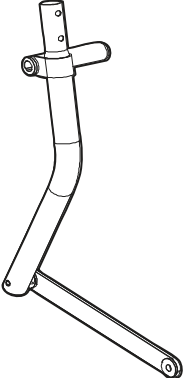
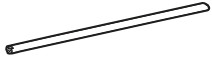
The scope of delivery consist of the following parts. At the beginning, check whether all parts and tools belonging to the device are included in the scope of delivery and whether damage has occurred. In the event of complaints, the contractual partner must be contacted directly.

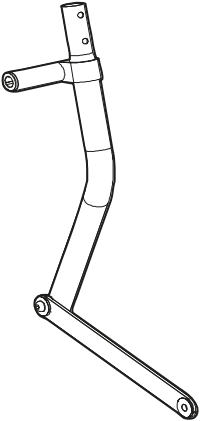
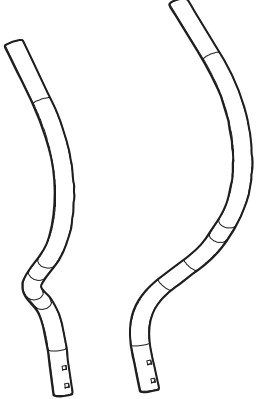
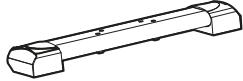
CAUTION
If parts of the scope of delivery are missing or damaged, the assembly must not be carried out.

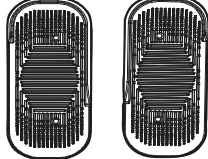
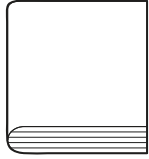
 <p>NO. 1 / 9L / 9R / 39 Main Fame × 1set</p>	 <p>NO. 86 Middle Handlebar × 1set</p>	 <p>NO. 41 Monitor × 1pc</p>  <p>NO. 83 Pedal Subplate × 1set</p>
 <p>NO. 29L / 25 Left Swing Rod with Connect Metal × 1set</p>	 <p>NO. 49 Long Axis × 1pc</p>	 <p>NO. 89 Bottle Holder × 1pc</p>
 <p>NO. 29R / 25 Right Swing Rod with Connect Metal × 1set</p>	 <p>NO. 34L / 34R L&R Handlebar × 1set</p>	 <p>NO. 2 Front Bottom Tube × 1pc</p>  <p>NO. 3 Rear Bottom Tube × 1pc</p>
 <p>NO. 10L / 10R Pedal (L/R) × 1set</p>	 <p>User Manual × 1pc</p>	

Step 1

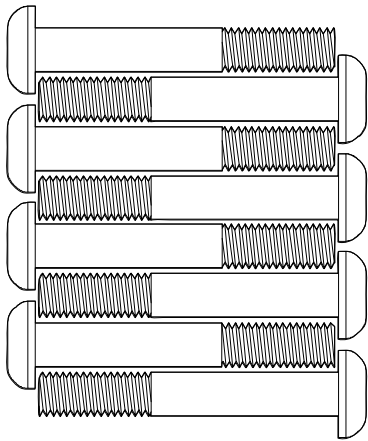

NO.4 Screw (M8x55) × 8pcs

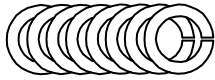

NO.5 Spring Washer (D8) × 8pcs



NO.6 Flat Washer (D8) × 8pcs

Step 2

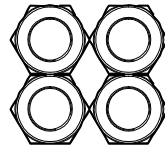

NO.12 Nylon Nut (M8) × 4pcs

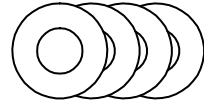

NO.6 Washer (D8) × 4pcs

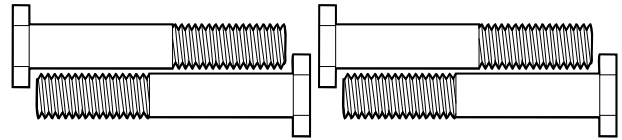

NO.11 Bolt (B8x50) × 4pcs

Step 3

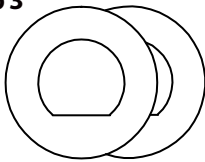

NO.30 Washer (ø16xø28) × 2pcs

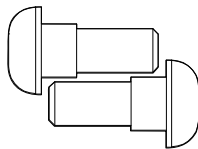

NO.26 Bolt (M8xø9) × 2pcs

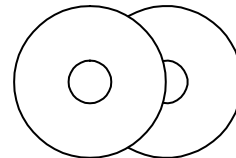

NO.31 Washer (D8xø28) × 2pcs



NO.32 Spring Washer (D8) × 2pcs

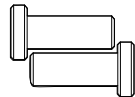

NO.33 Screw (M8x16) × 2pcs

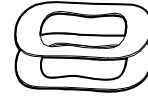

NO.95 Wave Washer (ø26xø16x0.3) × 2pcs

Step 4

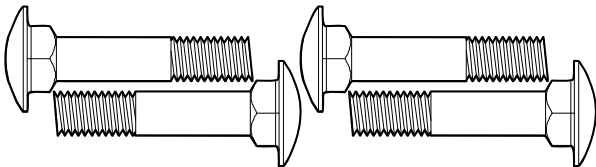

NO. 35 Bolt (M8x40) × 4pcs

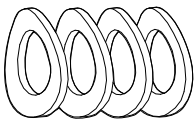

NO. 36 Washer (D8) × 4pcs

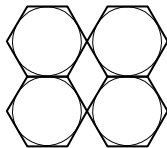

NO. 37 Nut (M8) × 4pcs

Step 5

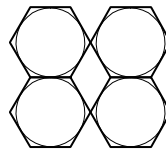

NO. 37 Nut (M8) × 4pcs

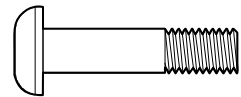

NO.42 Screw (M8x40) × 1pc

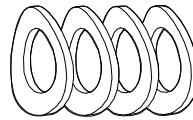

NO. 36 Washer (D8) × 4pcs

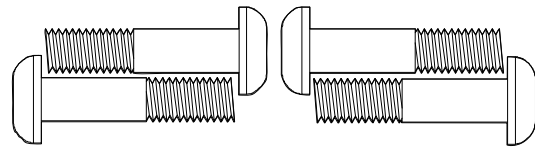

NO. 87 Screw (M8x35) × 4pcs

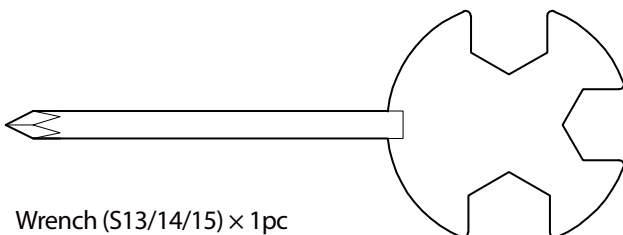

Wrench (S13/14/15) × 1pc



Wrench × 2pcs

3.3 Assembly

Before assembly, take a close look at the individual assembly steps shown and carry out the assembly in the order given.

① NOTICE

First loosely screw all parts together and check that they fit properly. Tighten the screws using the tool only when you are instructed to do so.

Step 1: Assembly of the Stabilizers and the Covers

1. Mount the front stabilizer (2) and the rear stabilizer (3) to the main frame (1) with four screws (4), four spring washers (5) and four washers (6) on each of the stabilizers (2 & 3).
2. Mount the left and right decorative covers (70L & 70R) to the main frame (1) with two screws (73) and one screw (72) on each side.

	NO.4 Screw (M8x55) × 8pcs
	NO.5 Spring Washer (D8) × 8pcs
	NO.6 Flat Washer (D8) × 8pcs
	NO.72 Screw (ST4.2x20) × 2pcs
	NO.73 Screw (ST4.2x12) × 4pcs

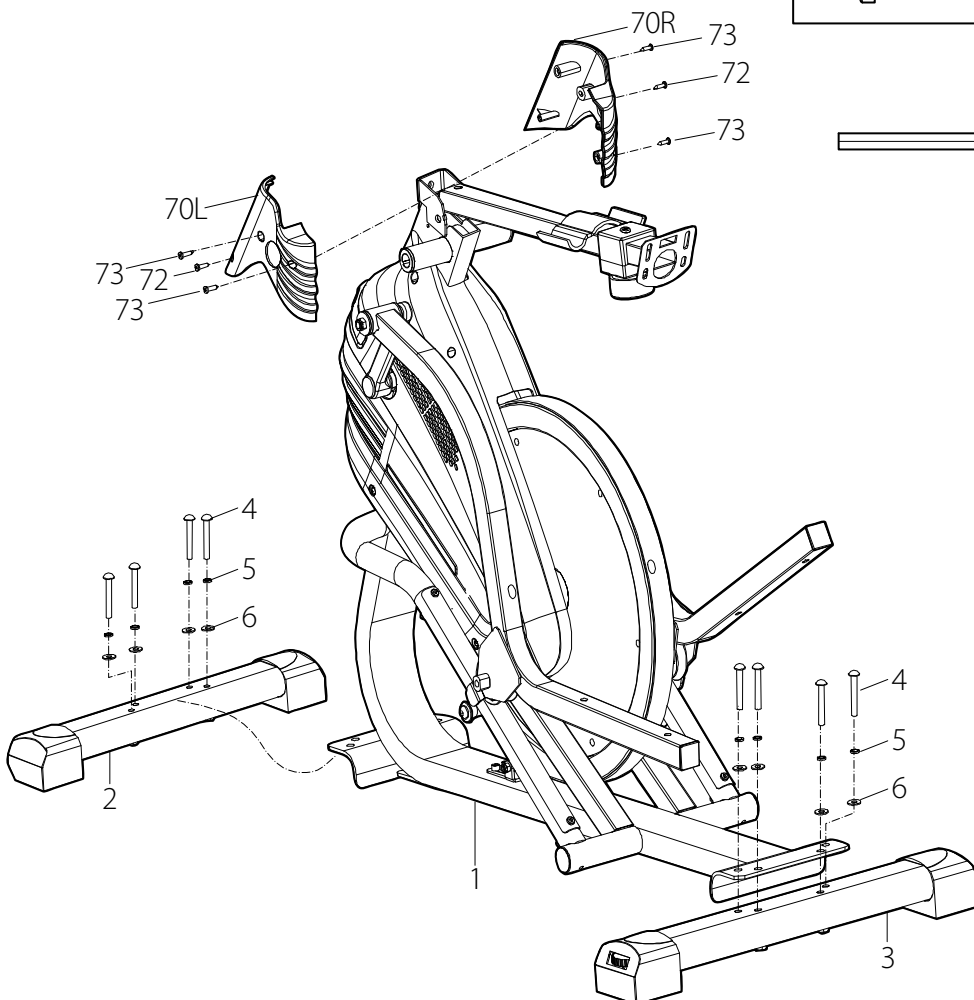





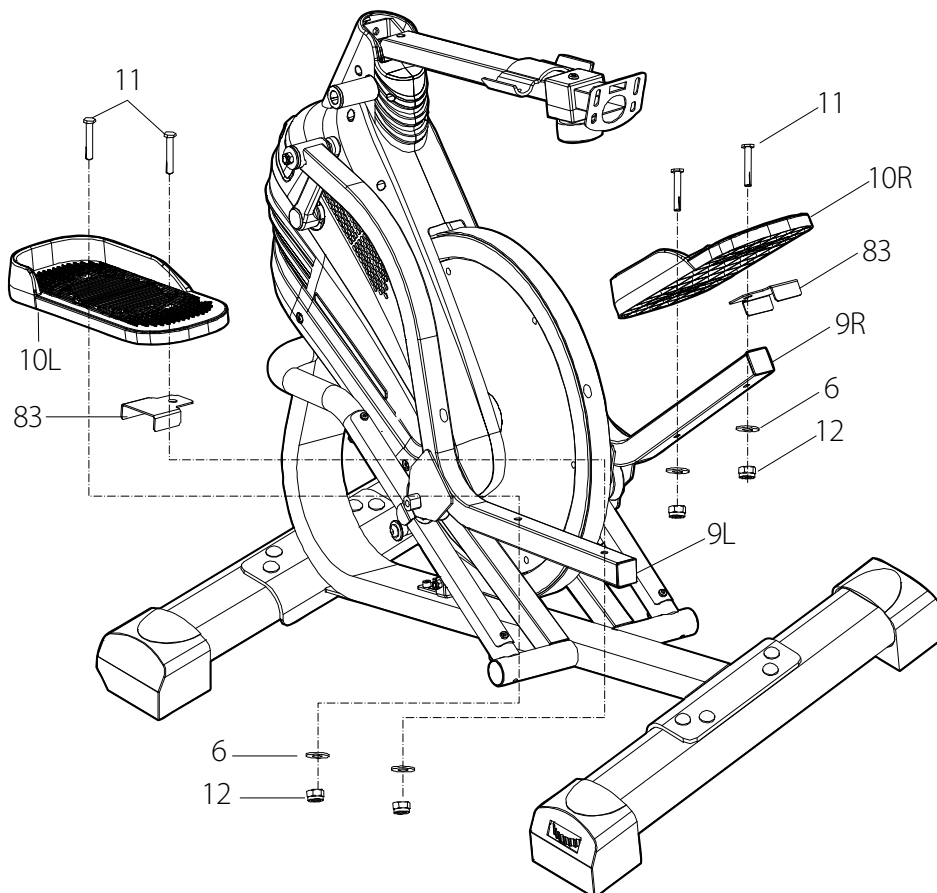
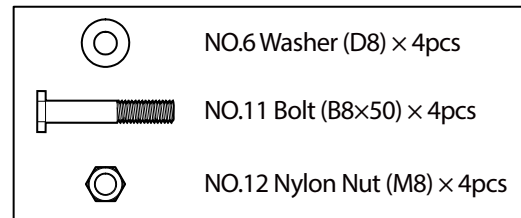

Step 2: Assembly of the Pedals

1. Place one pedal plate (83) on each of the pedal welds (9R & 9L).
2. Mount the pedals (10R & 10L) to their respective pedal weld (9R & 9L) with two screws (11), two washers (6) and two nylon nuts (12) on each side.



Step 3: Assembly of the Swing Rods

1. Slide the long axis (49) through the connection at the top centre of the main frame (1).
2. Mount the right swing rod (29R) to the right of the long axis (49) with one screw (33), one spring washer (32), one washer (31), one washer (30) and one wave washer (95).
3. Mount the connect metal of the right swing rod (25) to the right pedal weld (9R) with one screw (26) and two washers (27).
4. Repeat the steps 2 and 3 on the left side.

	NO.26 Bolt (M8xø9) × 2pcs
	NO.30 Washer (ø16xø28) × 2pcs
	NO.31 Washer (D8xø28) × 2pcs
	NO.32 Spring Washer (D8) × 2pcs
	NO.33 Screw (M8x16) × 2pcs
	NO.95 Wave Washer (ø26xø16x0.3) × 2pcs

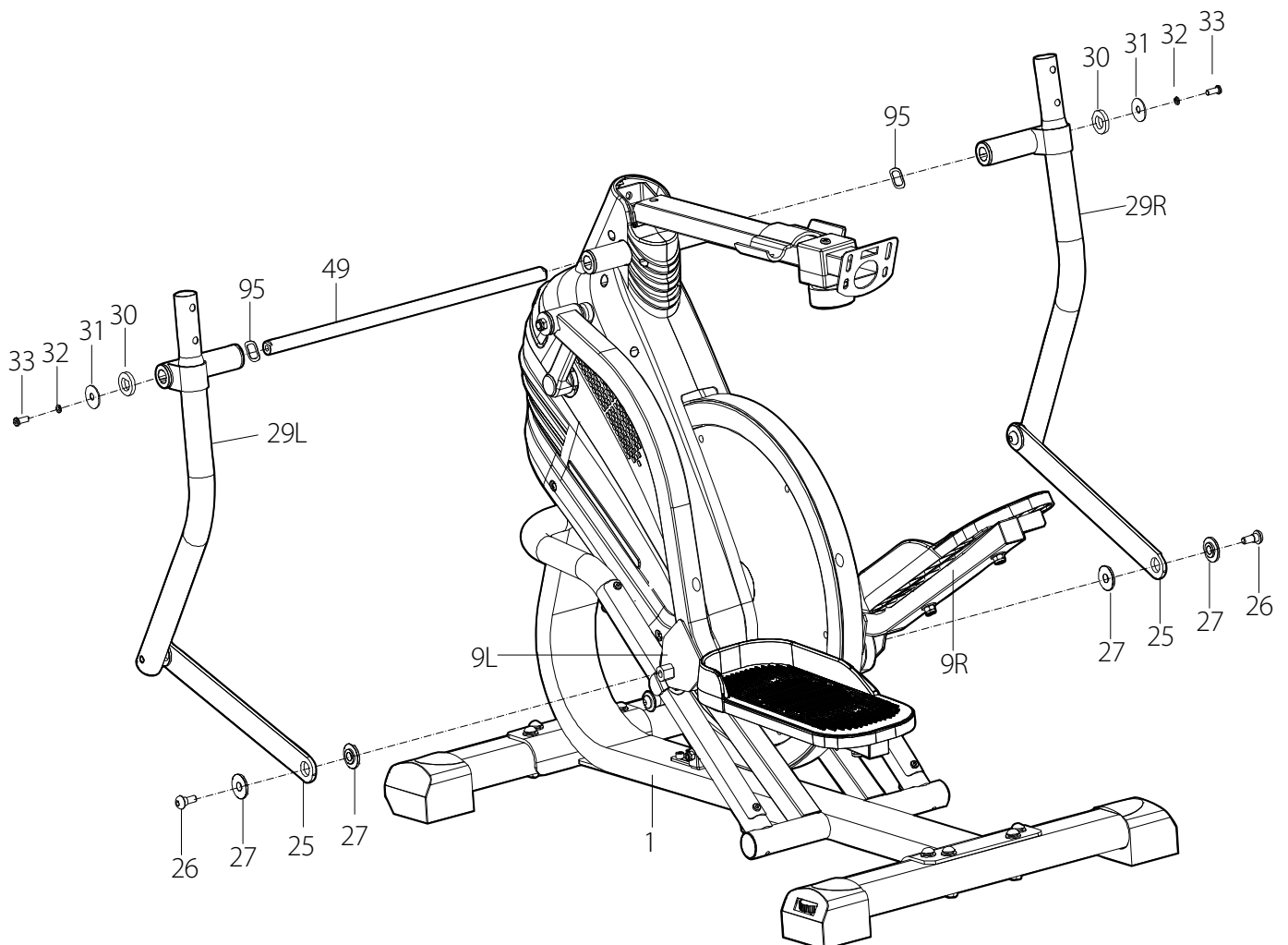
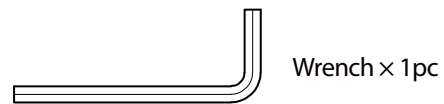



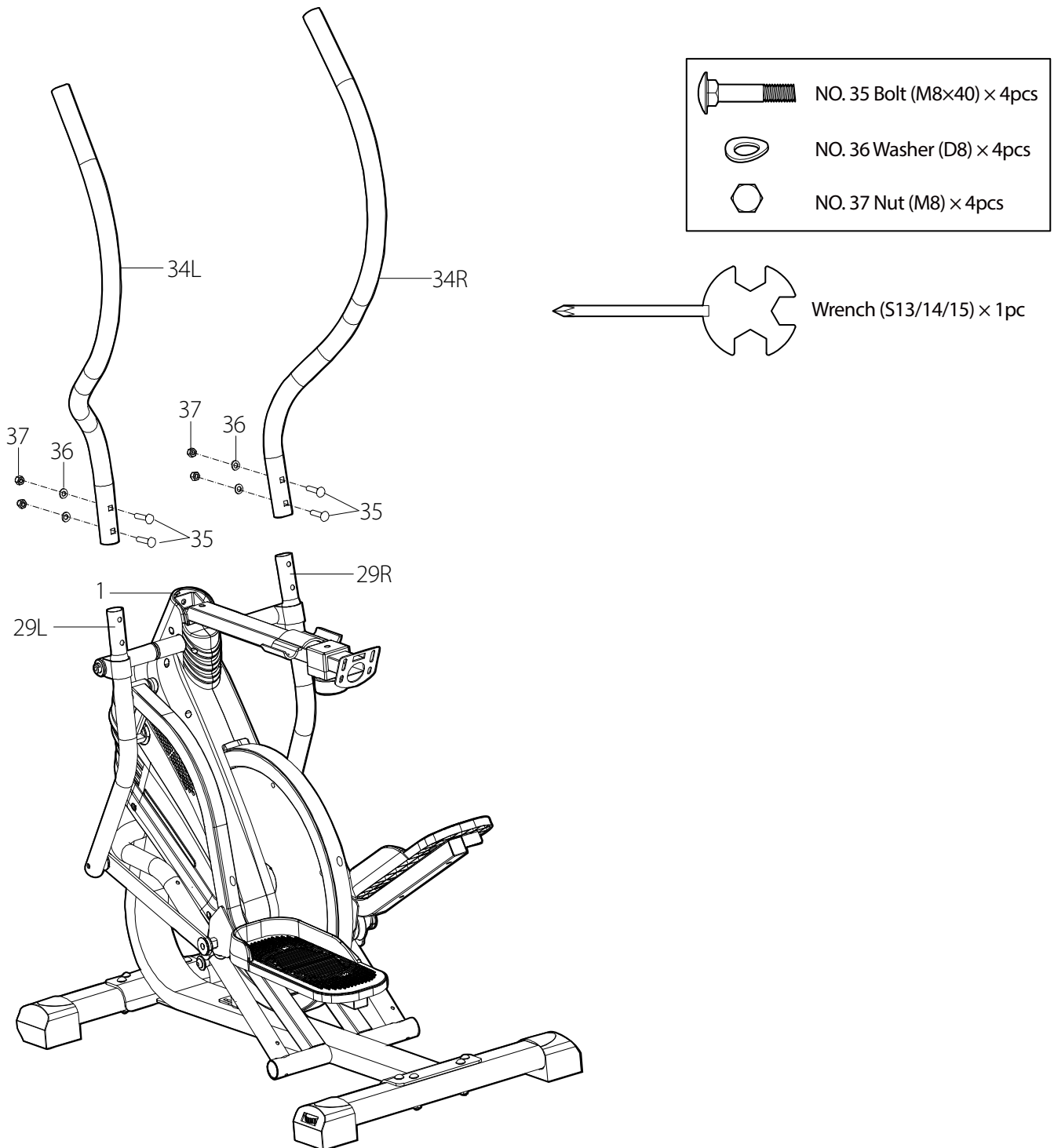

Step 4: Assembly of the Handlebars

Mount the left and right handlebars (34L & 34R) to their respective swing rod (29L & 29R) with two screws (35), two washers (36) and two nuts (37) on each side.

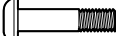

Step 5: Assembly of the Middle Handlebar

1. Slide the mid handlebar weld (39) into the main frame (1).
2. Mount the mid handlebar weld (39) to the main frame (1) with one screw (42).
3. Mount the middle handlebar (86) to the mid handlebar weld (39) with four screws (87), four washers (36) and four nuts (37).
4. Connect the hand pulse sensors of the middle handlebar (90) to the lower cables of the mid handlebar weld (96).

	NO. 36 Washer (D8) × 4pcs
	NO. 37 Nut (M8) × 4pcs
	NO. 42 Screw (M8×40) × 1pc
	NO. 87 Screw (M8×35) × 4pcs

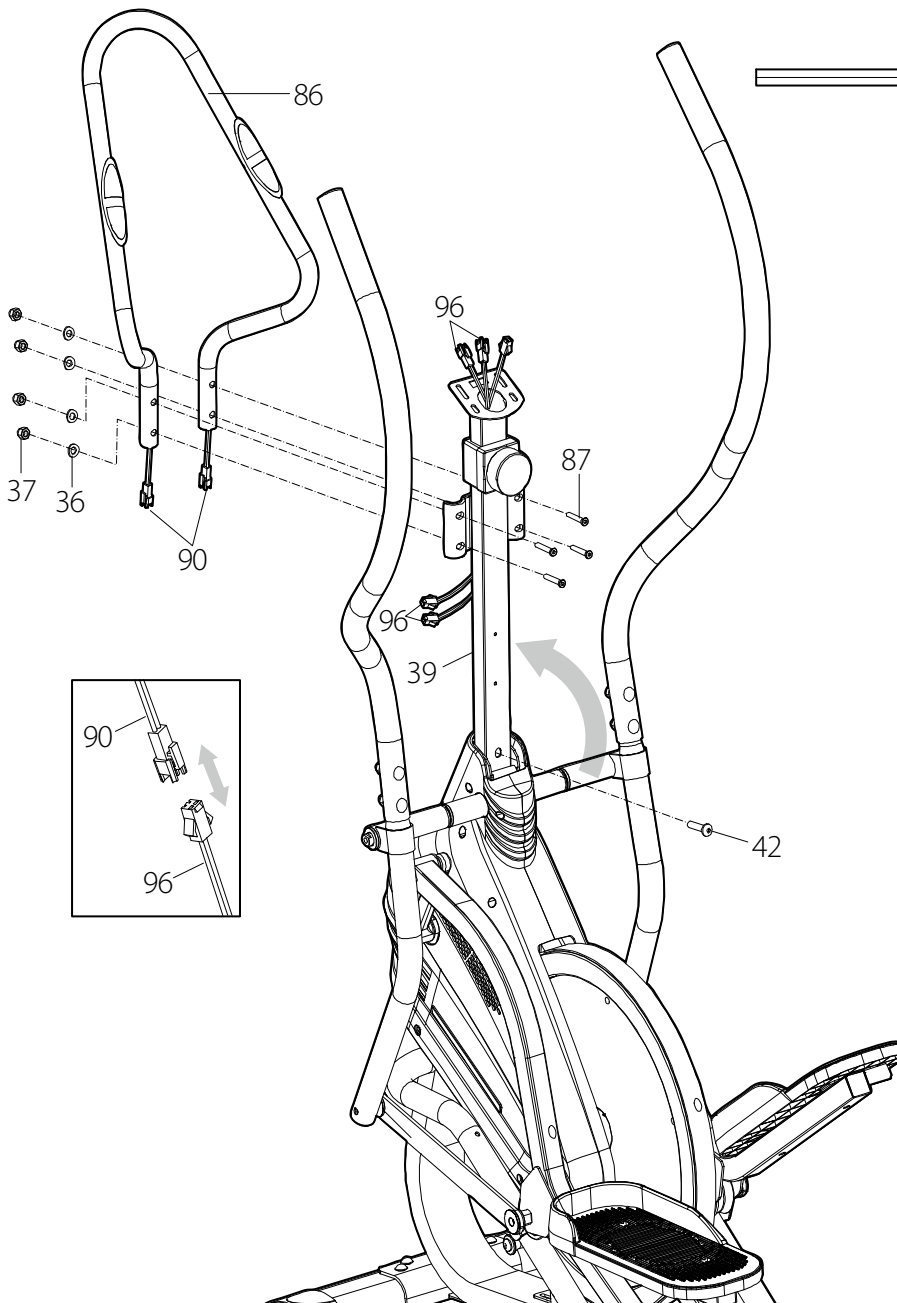
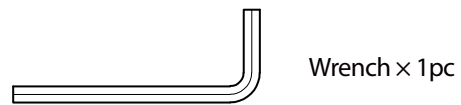

Step 6: Assembly of the Monitor and the Bottle Holder

1. Connect the cables of the mid handlebar weld (80 & 96) to the cables of the monitor (41).

► **ATTENTION**

Make sure not to pinch the cables during the following step.

2. Mount the monitor (41) to the mid handlebar weld (39) with two screws (84).
3. Mount the bottle holder (89) to the mid handlebar weld (39) with two screws (92).
4. Now tighten all screw joints with the necessary tools.
→ The assembly of the equipment is completed.

 NO. 84 Screw (M5x10) × 2pcs

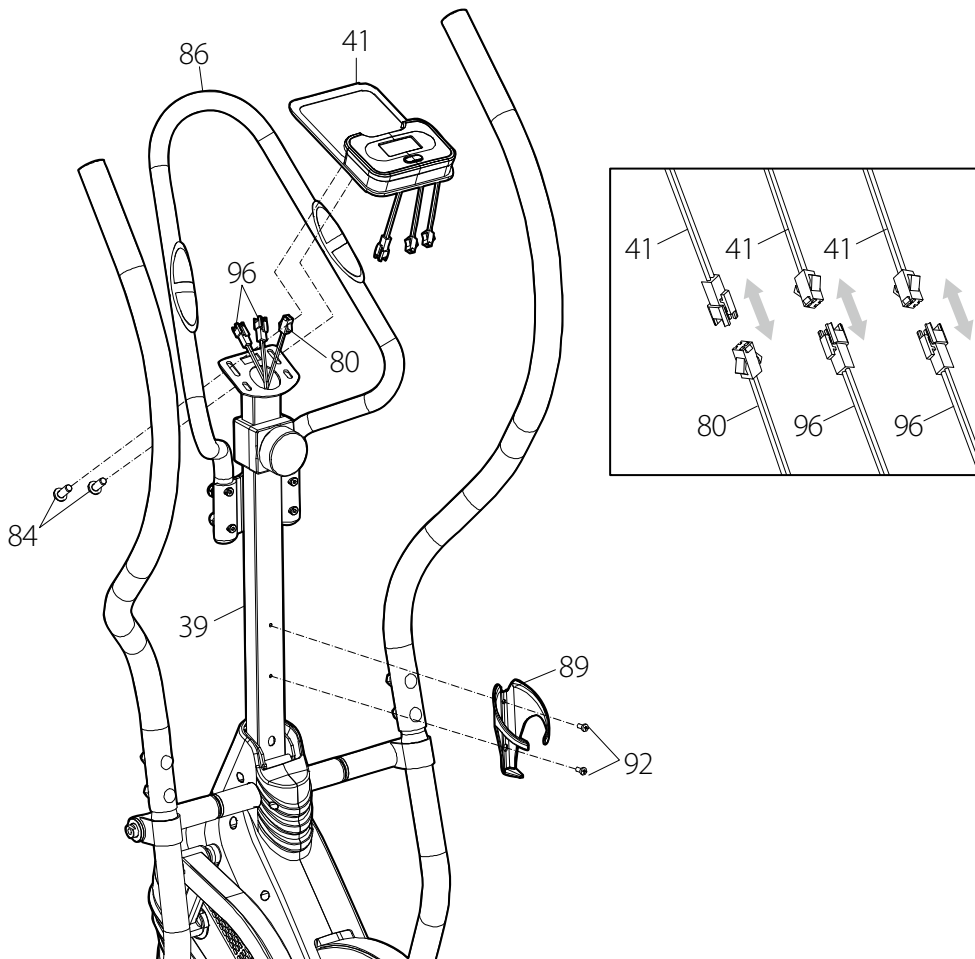
 NO. 92 Screw (M5x10) × 2pcs

Step 7: Alignment of the Feet

If the floor is uneven, you can stabilize the equipment by turning the setting screws under the main frame.

1. Lift the equipment on the desired side and rotate the setting screws under the main frame.
2. Rotate the screws clockwise in order to remove them and to raise the equipment.
3. Rotate the screws counterclockwise in order to lower the equipment.

① NOTICE

Familiarise yourself with all the functions and setting options of the device before starting training. Have the proper use of this product explained to you by a specialist.

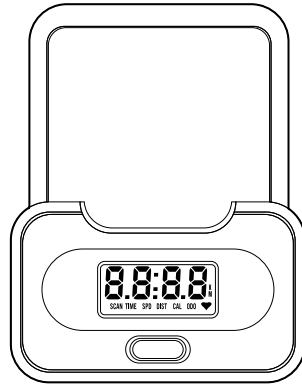
4.1 Console Display

Scan	Displays a different training value every six seconds
Time	Displays the remaining or elapsed training time (00:00 -99:59 min)
Speed	Displays the current training speed (0 - 999.9 km/h)
Distance	Displays the remaining distance or the distance traveled
Odometer	Displays the total amount of distance traveled since first use (0 - 9999 km)
Calories	Displays the total amount of burned calories (0 - 9999 kcal)
Pulse Rate	<p>Displays the current heart rate.</p> <p>⚠ WARNING Your training equipment is not a medical device. The heart rate measurement of this equipment may be inaccurate. Various factors can affect the accuracy of the heart rate measurement. The heart rate measurement serves only as a training aid.</p>
Battery	AAA Battery (2x)
Operating Temperature	0 ~ 40°C (32 °F ~ 104 °F)
Storage Temperature	-10 ~ 60°C

4.2 Functions Button

Functions Button	<p>+ By pressing the functions button, you can choose between functions, such as TIME - SPEED - DIST - CALORIES(CAL) - ODO - PULSE RATE wechseln</p> <p>+ In order to reset a value, press and then hold the respective button for 3 seconds</p>
------------------	--------------------------------------------------------------------------------------------------------------------------------------------------------------------------------------------------------------------------------------------------

4.3 Hibernation

The console enters hibernation mode automatically if the sensor does not receive a signal. The console will turn on again once the functions button is pressed or the sensor receives a signal.

5.1 General Instructions

WARNING

- + The storage location should be chosen so that improper use by third parties or children can be prevented.
- + If your equipment does not have transportation wheels, the equipment must be disassembled before transportation.

ATTENTION

- + Make sure that the equipment is protected from moisture, dust and dirt in the selected storage location. The storage location should be dry and well ventilated and have a constant ambient temperature between 10°C and 35°C.

5.2 Folding Mechanism

ATTENTION

- + If you want to transport your equipment over particularly sensitive and soft floor coverings, such as parquet, planks or laminate, lay out the transport route with cardboard or similar to avoid possible floor damage.
1. Stand in front of the equipment and lift it until the weight is transferred to the transportation wheels. After that, you easily can move the equipment to a new position. For long transport distances the equipment should be disassembled and safely packed.
 2. Select the new location by following the instructions in the section 1.3 of this manual.

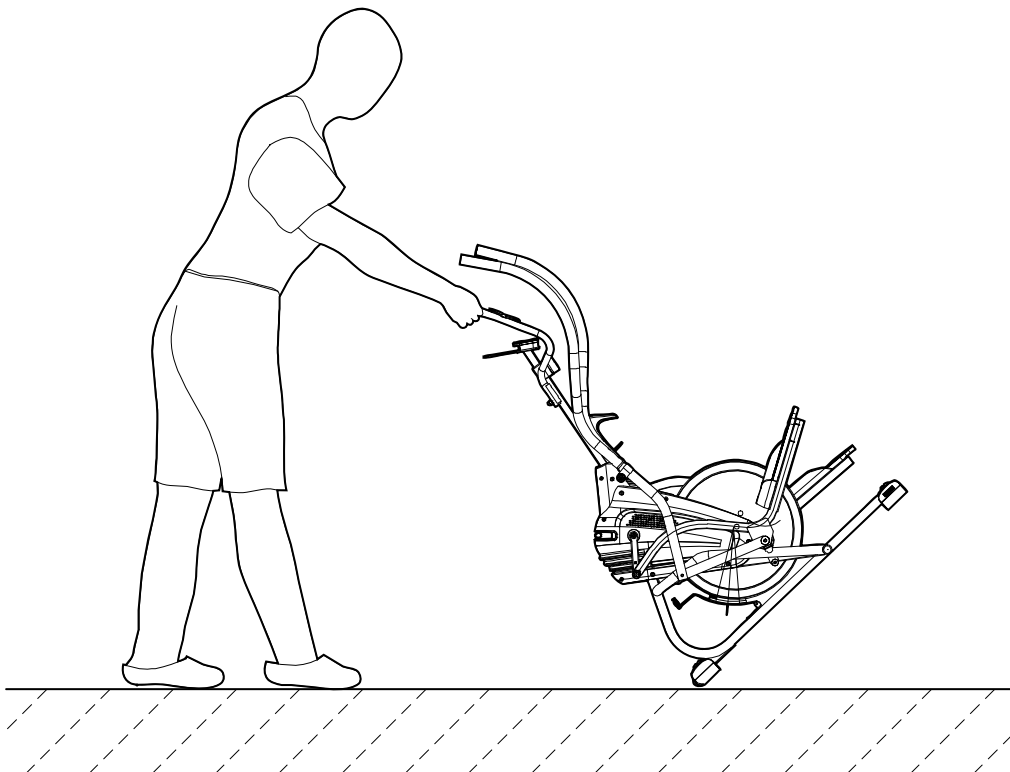

6.1 General Instructions

WARNING

- + Do not make any improper changes to the equipment.

CAUTION

- + Damaged or worn components may affect your safety and the life of the equipment. Therefore, immediately replace damaged or worn components. In such a case, contact the contract partner. The equipment must not be used until it has been repaired. If necessary, use only original spare parts.

ATTENTION

- + In addition to the instructions and recommendations for maintenance and care given here, additional service and/or repair work may be necessary; this must only be carried out by authorised service technicians.

6.2 Faults and Fault Diagnosis

The equipment undergoes regular quality controls during production. Nevertheless, faults or malfunctions may occur. Frequently, individual parts are responsible for these disturbances, an exchange is usually sufficient. Please refer to the following overview for the most common errors and how to correct them. If the equipment still does not function properly, contact your contract partner.

Fault	Cause	Solution
Drive disks wobble/make noises	Drive disk loose	Tighten nut (pay attention to left-hand / right-hand thread)
Display is blank/is not working	Loose cable connections	Check cable connections
Equipment wobbles	Equipment is not level	Align the feet
Creaking noises on the stepping area	Loose screws on stepping area	Tighten the screws on the stepping area
Creaking noises	Screw connections loosened or too tight	Check screw connections
Squeaking noises on the guide rails	Guide rails or rollers dirty or guide rails dry	Clean the guide rails and then lubricate them with a suitable lubricant
No pulse display	<ul style="list-style-type: none"> + Sources of interference in the room + Unsuitable chest strap + Wrong position of chest strap + Chest strap defective or battery empty + Pulse display defective 	<ul style="list-style-type: none"> + Eliminate sources of interference (e.g. mobile phone, WLAN, lawn mower and vacuum cleaner robot, etc. ...) + Use a suitable chest strap (see RECOMMENDED ACCESSORIES). + Reposition chest strap and/or moisten electrodes + Changing batteries + Check if pulse display by hand pulse possible

6.3 Maintenance and Inspection Calendar

To avoid damage from body sweat, the equipment must be cleaned with a damp towel (no solvents!) after each training session.

The following routine tasks must be performed at the specified intervals:

Part	Weekly	Monthly	Quarterly
Display console	C	I	
Slide rails			C
Lubrication of slide rails and moving parts			I
Plastic covers	C	I	
Screws and cable connections		I	
Legend: C = clean; I = inspect			

7 DISPOSAL

At the end of its operational life, this equipment cannot be disposed of in normal household waste. Instead, it must be disposed of via a recycling centre. Further information can be obtained from your local authority's recycling service.



The materials can be recycled as per their symbols. Through the reuse, recycling of materials or other forms of recovery of old equipment, you make an important contribution to the protection of the environment.

8 RECOMMENDED ACCESSORIES

To make your training experience even more efficient and pleasant, we recommend that you add suiting accessories to your fitness equipment. This could be a floor mat, for example, which makes your fitness equipment stand more securely and also protects the floor from falling sweat, but it could also be additional handrails on some treadmills or silicone spray to keep moving parts in good shape.

If you have purchased a fitness machine with pulse training and want to train your heart rate, we strongly recommend that you use a compatible chest strap, as this ensures optimum transmission of the heart rate. You may want to buy additional grips or weights for multi gyms.

Our range of accessories offers the highest quality and makes training even better. If you would like to find out more about compatible accessories, please go to the detail page of the product in our webshop (the easiest way is to enter the article number in the search field above) and go to the recommended accessories on this page. Of course, you can also contact our customer service: by telephone, e-mail, in one of our branches or via our social media channels. We will be happy to advise you!



9.1 Serial Number and Model Name

In order to provide you with the best possible service, please have the model name, article number, serial number, exploded drawing and parts list ready. The corresponding contact options can be found in chapter 10 of this operating manual.

NOTICE

The serial number of your equipment is unique. It's located on a white sticker. The exact position of this sticker is shown in the following illustration.

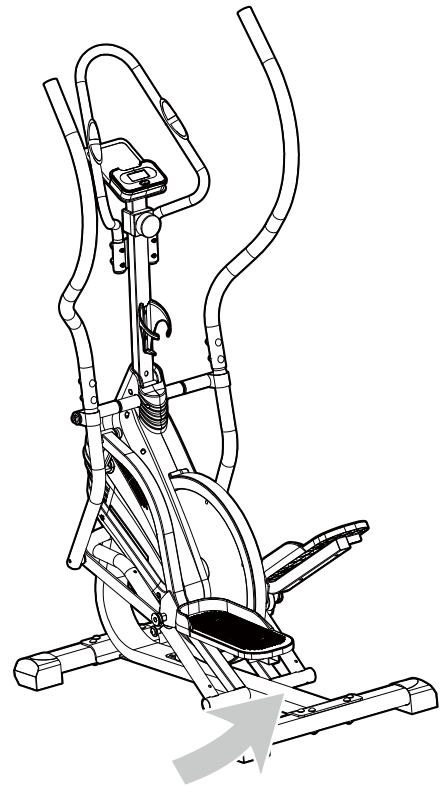

Enter the serial number in the appropriate field.

Serial number:

Brand / Category:

BodyMax / Stepper

Model Name:

MXT40-M2 Apex Trainer

SKU-Code:

CVET2706

9.2 Parts List

No.	Name	Qt'y	No.	Name	Qt'y	No.	Name	Qt'y
1	Main Frame	1	34L/R	Handlebar (L/R)	2	68	Screw (M5×12mm)	2
2	Front Stabilizer	1	35	Bolt (M8×40mm)	4	69L/R	Chain Cover (L&R)	2
3	Rear Stabilizer	1	36	Washer (D8)	8	70L/R	Decoration Cover (L&R)	2
4	Screw (M8×55mm)	8	37	Nut (M8)	8	71	Decorative Strip	1
5	Spring Washer (D8)	13	38	Foam	2	72	Screw (ST4.2×20mm)	13
6	Washer (D8×ø16×15×1.5)	12	39	Mid Handlebar Weld	1	73	Screw (ST4.2×12mm)	4
7	Feet Cap	2	40	Screw (M8×55mm)	1	74	Screw (ST4.8×19mm)	2
8	Adjustable Feet Cap	2	41	Monitor	1	75	Screw (ST4.2×20mm)	5
9L/R	Pedal Weld	2	42	Screw (M8×40mm)	1	76	Tension Control	1
10L/R	Pedal (L/R)	2	43	Washer (D8×ø28×2)	2	77	Tension Control Back Cover	1
11	Bolt (M8×50mm)	4	44L/R	Crank (L&R)	2	78	Screw (M5×20mm)	1
12	Nylon Nut (M8)	7	45	Axis (6203ZZ)	2	79	Belt	1
13	Axis Cap	10	46	Screw (M6×15mm)	4	80	Sensor Wire	1
14	Slide Board	2	47	Mid Axis	1	81	Washer (ø8.5×ø19×2)	2
15	Screw (M6×45mm)	4	48	Belt wheel	1	82	Tube Pad	1
16	Nylon Nut (M6)	9	49	Long Axis	1	83	Pedal Plate	2
17	Round Tube Cap	4	50	Crank (L/R)	1	84	Screw (M5×10mm)	2
18	Screw	2	52	Crank Cap	2	85	Washer (D16)	2
19	Axis (6200Z)	4	53	Nut (M10×1.25)	2	86	Middle Handlebar	1
20	Slider Wheel	2	54	Flywheel Axis	1	87	Screw (M8×35mm)	4
21	Bolt (M8×12×ø10×32mm)	2	55	Axis (6000RS)	2	88	Foam	1
22	Sub Wheel	2	56	Flywheel	1	89	Bottle Holder	1
23	Nylon Nut (M10)	2	57	Nut (M10)	2	90	Hand Pulse Sensor	2
24	Squared Cap	2	58	Chain Bolt	1	91	Screw (ST4.2×18)	2
25	Connect Metal	2	59	Nut (M10×1mm)	2	92	Screw (M5×10)	2
26	Bolt (M8×9×ø10×12mm)	2	60	Nut (M6)	6	93	Spring Washer (D6)	4
27	Sleeve	8	61	Brake Weld	1	94	Screw (M6×70mm)	1
28	Bolt (M8×12×ø10×12×31mm)	2	62	Magnetic Metal Board	1	95	Wave Washer (ø26×ø16×0.3)	2
29L/R	Swing Rod (L/R)	2	63	Magnetic	4	96	Plug Wire	1
30	D Washer	2	64	Brake Fix Seat	1	97	Plug	1
31	Washer (D8×ø28×2mm)	2	65	Brake Shock Pad	1	98	Tube Plug	1
32	Spring Washer (D8)	2	66	Screw (M6×50mm)	1	A	Wrench (S6)	2
33	Screw (M8×16mm)	2	67	Spring	1	B	Wrench (S13/14/15)	1

9.3 Exploded drawing

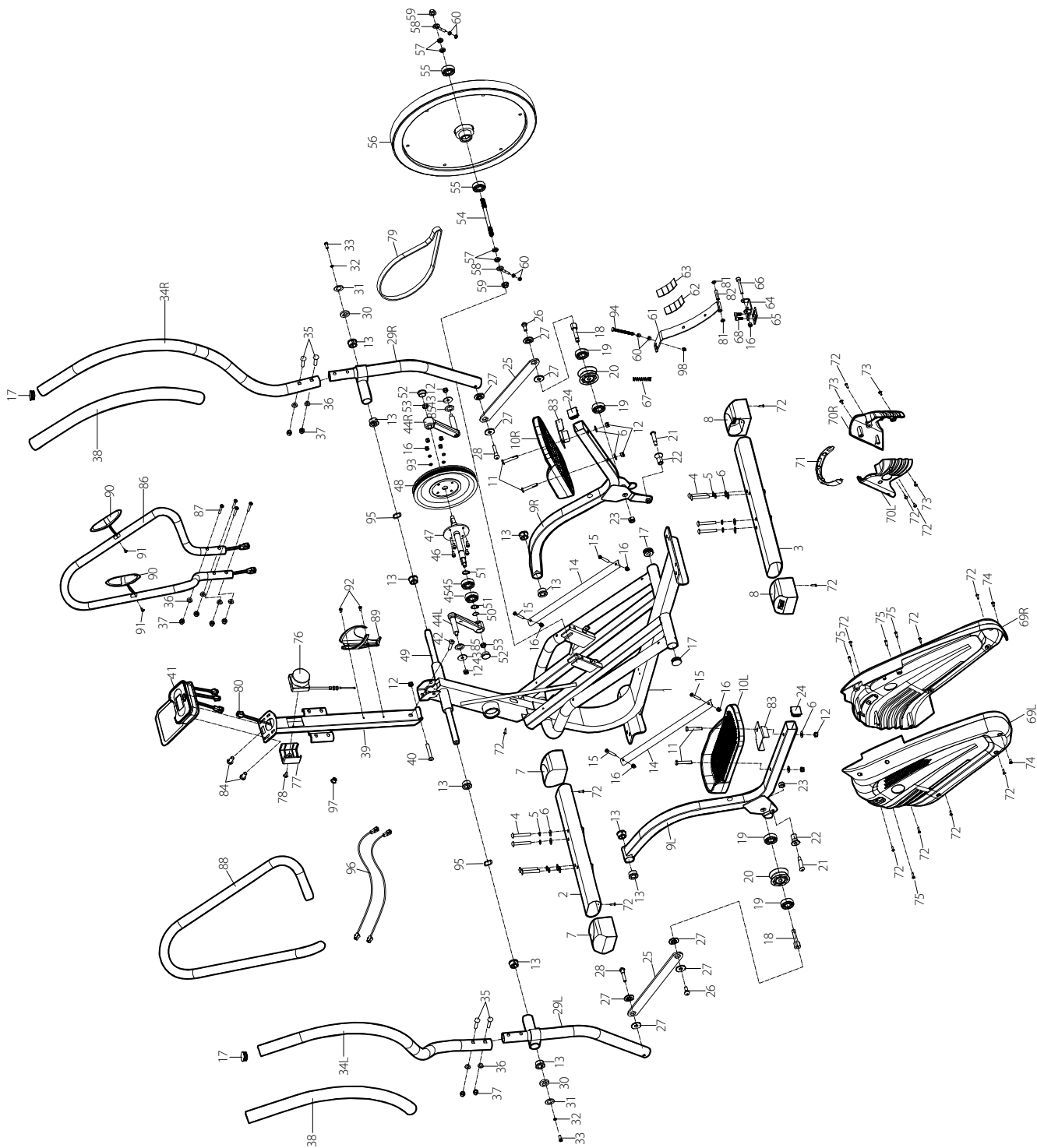

Training equipment from BodyMax Fitness® is subject to strict quality control. However, if a fitness equipment purchased from us does not work perfectly, we take it very seriously and ask you to contact our customer service as indicated. We are happy to help you by phone via our service hotline.

Error descriptions

Your fitness equipment is developed for long-term, high-quality training. However, should a problem arise, please first read the operating instructions. For further assistance, please contact your contract partner or call our service hotline. To ensure your problem is solved as quickly as possible, please describe the defect as exactly as possible.

In addition to the statutory warranty, we provide a warranty for every fitness equipment purchased from us according to the following provisions.

Your statutory rights are not affected.

Warrantee

The warrantee is the first/original buyer and/or any person who received a newly purchased product as a gift from the original buyer.

Warranty periods

The following warranty periods begin on delivery of the fitness equipment.

Model	Use	Full warranty
MXT40-M2	Home Use	1 Year

Repair costs

According to our choice, there will either be a repair, a replacement of individual damaged parts or a complete replacement. Spare parts, that have to be mounted while assembling the equipment, have to be replaced by the warrantee personally and are not a part of repair. After the expiration of the warranty period for repair costs, a pure parts warranty applies, which does not include the repair, installation and delivery costs.

The terms of use are defined as follows:

- Home use: solely for private use in private households up to 3 hours per day
- Semi-professional use: up to 6 hours per day (e. g. rehabilitation centers, hotels, clubs, company gyms)
- Professional use: more than 6 hours per day (e. g. commercial gyms)

Warranty service

Within the warranty period, equipment which develops faults as a result of material or manufacturing defects, will be repaired or replaced at our discretion. Ownership of equipment or parts of equipment which have been replaced is transferred to us. The warranty period is not extended nor does a new warranty period begin following repair or replacement under the warranty.

Warranty conditions

For the warranty to be valid, the following steps must be taken:

Please contact our customer service by email or phone. If the product under warranty has to be sent in for repair, the seller bears costs. After expiry of the warranty, the buyer bears the costs of transport and insurance. If the fault is covered by our warranty, you will receive a new or repaired equipment in return.

Warranty claims are invalid in case of damage resulting from:

- misuse or improper handling
- environmental influences (moisture, heat, electrical surge, dust, etc.)
- failure to follow the current safety measures for the equipment
- failure to follow the operating instructions
- use of force (e. g. hitting, kicking, falling)
- interventions which were not carried out by one of our authorized service centers
- unauthorized repair attempts

Proof of purchase and serial number

Please make sure that you are able to provide the appropriate receipt when claiming on your warranty. So that we can clearly identify the model of your equipment, and for the purposes of our quality control, you will need to give the serial number of your equipment, when contacting the service team. Where possible please have your serial number and your customer number ready when you call our service hotline. It will help us to deal with your request swiftly.

If you cannot find the serial number on your training equipment, our service employees are ready to help.

Service outside the warranty period

We are also happy to issue an individual cost estimate if there is a problem with your fitness equipment after the warranty has expired, or in cases which do not fall under the terms of the warranty, e. g. normal wear and tear. Please contact our customer service team to find a quick and cost-effective solution to your problem. In such a case you will be responsible for the delivery costs.

Communication

Many problems can be solved just by speaking to us as your specialist supplier. We know how important it is to you as a user of the fitness equipment to have problems solved quickly and simply, so you can enjoy working out with minimal interruption. For that reason, we also want to resolve your queries quickly and in a straightforward manner. Thus, please always keep your customer number and the serial number of the faulty equipment handy.

DE	DK	FR
<p>TECHNICAL SUPPORT</p> <p> +49 4621 4210-900</p> <p> +49 4621 4210-698</p> <p> technik@sport-tiedje.de</p> <p> Mo - Fr 08:00 - 18:00 Sa 09:00 - 18:00</p> <p>SERVICE</p> <p> 0800 20 20277 (Freecall)</p> <p> info@sport-tiedje.de</p> <p> Mo - Fr 08:00 - 21:00 Sa 09:00 - 21:00 So 10:00 - 18:00</p>	<p>TECHNICAL SUPPORT & SERVICE</p> <p> 80 90 16 50</p> <p>+49 4621 4210-945</p> <p> info@fitshop.dk</p> <p> Mo - Fr 08:00 - 18:00 Sa 09:00 - 18:00</p>	<p>TECHNICAL SUPPORT & SERVICE</p> <p> +33 (0) 172 770033</p> <p>+49 4621 4210-933</p> <p> service-france@fitshop.fr</p> <p> Mo - Fr 08:00 - 18:00 Sa 09:00 - 18:00</p>
	PL	BE
	<p>TECHNICAL SUPPORT & SERVICE</p> <p> 22 307 43 21</p> <p>+49 4621 42 10-948</p> <p> info@fitshop.pl</p> <p> Mo - Fr 08:00 - 18:00 Sa 09:00 - 18:00</p>	<p>TECHNICAL SUPPORT & SERVICE</p> <p> 02 732 46 77</p> <p>+49 4621 42 10-932</p> <p> info@fitshop.be</p> <p> Mo - Fr 08:00 - 18:00 Sa 09:00 - 18:00</p>

UK	NL	INT
<p>TECHNICAL SUPPORT</p> <p> +44 141 876 3986</p> <p> support@powerhousefitness.co.uk</p> <p>SERVICE</p> <p> +44 141 876 3972</p> <p> Mo - Fr 9am - 5pm</p>	<p>TECHNICAL SUPPORT & SERVICE</p> <p> +31 172 619961</p> <p> info@fitshop.nl</p> <p> Ma - Do 09:00 - 17:00 Vr 09:00 - 21:00 Za 10:00 - 17:00</p>	<p>TECHNICAL SUPPORT & SERVICE</p> <p> +49 4621 4210-944</p> <p> service-int@sport-tiedje.de</p> <p> Mo - Fr 8am - 6pm Sat 9am - 6pm</p>
	AT	CH
	<p>TECHNICAL SUPPORT & SERVICE</p> <p> 0800 20 20277 (Freecall)</p> <p>+49 4621 42 10-0</p> <p> info@sport-tiedje.at</p> <p> Mo - Fr 08:00 - 18:00 Sa 09:00 - 18:00</p>	<p>TECHNICAL SUPPORT & SERVICE</p> <p> 0800 202 027</p> <p>+49 4621 42 10-0</p> <p> info@sport-tiedje.ch</p> <p> Mo - Fr 08:00 - 18:00 Sa 09:00 - 18:00</p>

Please find a detailed overview including address and opening hours for all stores of the Sport-Tiedje Group in Germany and abroad on the following website:

www.sport-tiedje.com/en/stores

DE	DK	FR
<p>TECHNICAL SUPPORT</p> <p>☎ +49 4621 4210-900</p> <p>☎ +49 4621 4210-698</p> <p>✉ technik@sport-tiedje.de</p> <p>🕒 Mo - Fr 08:00 - 18:00 Sa 09:00 - 18:00</p> <p>SERVICE</p> <p>☎ 0800 20 20277 (Freecall)</p> <p>✉ info@sport-tiedje.de</p> <p>🕒 Mo - Fr 08:00 - 21:00 Sa 09:00 - 21:00 So 10:00 - 18:00</p>	<p>TECHNICAL SUPPORT & SERVICE</p> <p>☎ 80 90 16 50</p> <p>+49 4621 4210-945</p> <p>✉ info@fitshop.dk</p> <p>🕒 Mo - Fr 08:00 - 18:00 Sa 09:00 - 18:00</p>	<p>TECHNICAL SUPPORT & SERVICE</p> <p>☎ +33 (0) 172 770033</p> <p>+49 4621 4210-933</p> <p>✉ service-france@fitshop.fr</p> <p>🕒 Mo - Fr 08:00 - 18:00 Sa 09:00 - 18:00</p>
	PL	BE
	<p>TECHNICAL SUPPORT & SERVICE</p> <p>☎ 22 307 43 21</p> <p>+49 4621 42 10-948</p> <p>✉ info@fitshop.pl</p> <p>🕒 Mo - Fr 08:00 - 18:00 Sa 09:00 - 18:00</p>	<p>TECHNICAL SUPPORT & SERVICE</p> <p>☎ 02 732 46 77</p> <p>+49 4621 42 10-932</p> <p>✉ info@fitshop.be</p> <p>🕒 Mo - Fr 08:00 - 18:00 Sa 09:00 - 18:00</p>

UK	NL	INT
<p>TECHNICAL SUPPORT</p> <p>☎ +44 141 876 3986</p> <p>✉ support@powerhousefitness.co.uk</p> <p>SERVICE</p> <p>☎ +44 141 876 3972</p> <p>🕒 Mo - Fr 9am - 5pm</p>	<p>TECHNICAL SUPPORT & SERVICE</p> <p>☎ +31 172 619961</p> <p>✉ info@fitshop.nl</p> <p>🕒 Ma - Do 09:00 - 17:00 Vr 09:00 - 21:00 Za 10:00 - 17:00</p>	<p>TECHNICAL SUPPORT & SERVICE</p> <p>☎ +49 4621 4210-944</p> <p>✉ service-int@sport-tiedje.de</p> <p>🕒 Mo - Fr 8am - 6pm Sat 9am - 6pm</p>
	AT	CH
	<p>TECHNICAL SUPPORT & SERVICE</p> <p>☎ 0800 20 20277 (Freecall)</p> <p>+49 4621 42 10-0</p> <p>✉ info@sport-tiedje.at</p> <p>🕒 Mo - Fr 08:00 - 18:00 Sa 09:00 - 18:00</p>	<p>TECHNICAL SUPPORT & SERVICE</p> <p>☎ 0800 202 027</p> <p>+49 4621 42 10-0</p> <p>✉ info@sport-tiedje.ch</p> <p>🕒 Mo - Fr 08:00 - 18:00 Sa 09:00 - 18:00</p>

Please find a detailed overview including address and opening hours for all stores of the Sport-Tiedje Group in Germany and abroad on the following website:

www.sport-tiedje.com/en/stores

WE LIVE FITNESS

WEBSHOP AND SOCIAL MEDIA

Sport-Tiedje is Europe's largest specialist store for home fitness equipment with currently over 70 stores and one of the world's most renowned online mail order companies for fitness equipment. Private customers order via the 25 web shops in the respective national language or have their desired equipment assembled on site. In addition, the company supplies fitness studios, hotels, sports clubs, companies and physio practices with professional equipment for endurance and strength training.

Sport-Tiedje offers a wide range of fitness equipment from renowned manufacturers, high-quality in-house developments and comprehensive services, such as a build-up service and sports scientific advice before and after the purchase. The company employs numerous sports scientists, fitness trainers and competitive athletes.

Visit us also on our social media platforms or our blog!

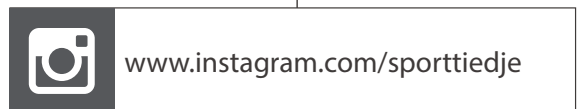
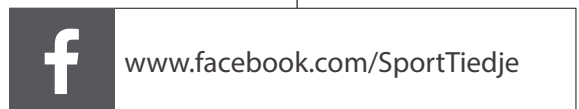

Notes

