

OWNER'S MANUAL

Lat/Row Machine

Model #: 660 LR

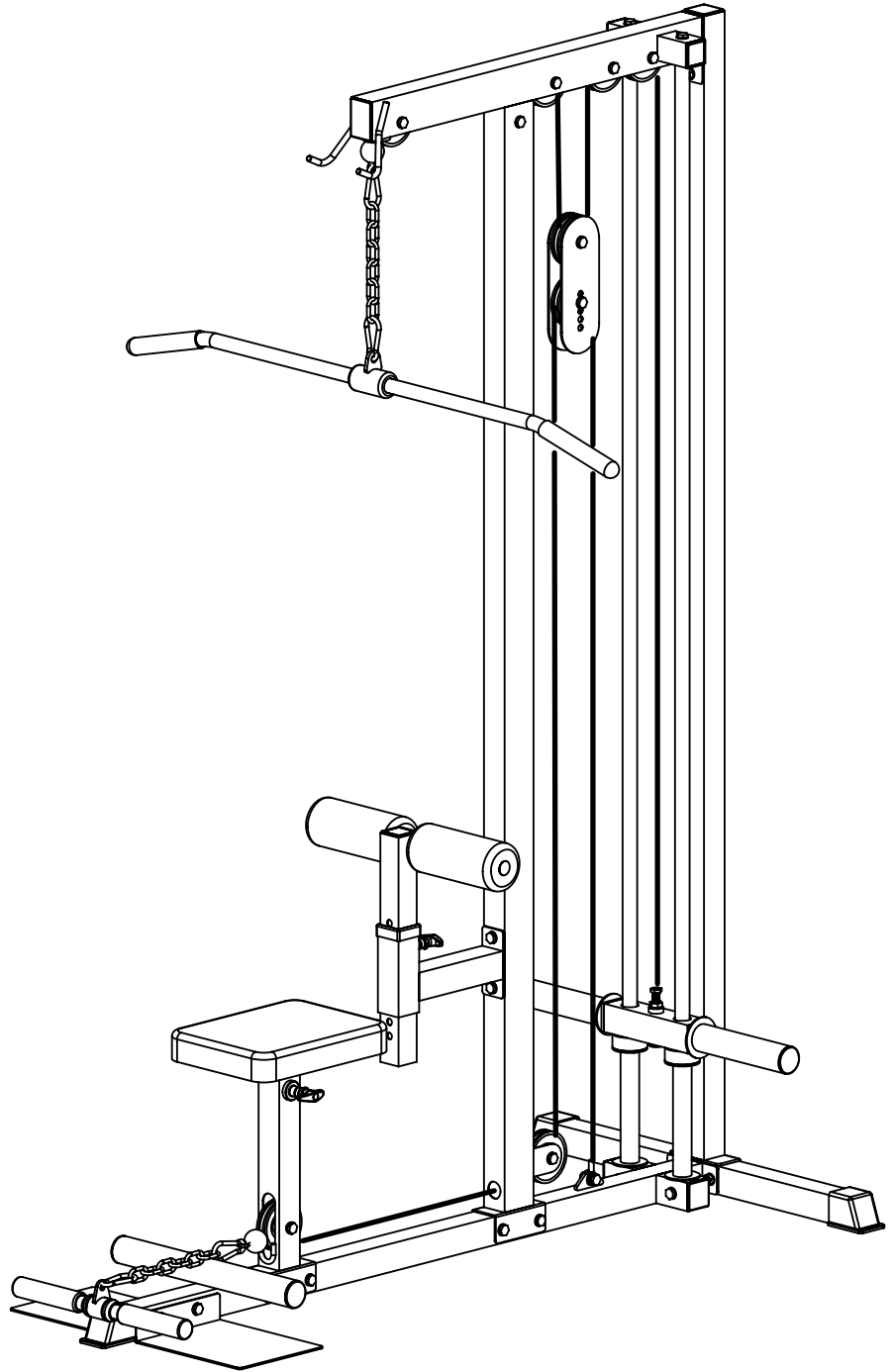

Caution: Read all precautions and instructions in this manual before using this equipment. Save this manual for future reference.

Assembly Instructions

Contents

Contents	1
Before You Begin	2
Assembly Steps	3-8
Parts&Hardware List	9-10

Assembly Instructions

Before Your Begin

This exercise equipment is built for optimum safety. Be sure to read the entire manual before you assemble or operate your equipment. Please note the following safety precautions:

1. Keep children and pets away from the equipment at all times. Do not leave children unattended in the same room with the equipment.
2. Only one person at a time should use the equipment.
3. If the user experiences dizziness, nausea, chest pain, or any other abnormal symptoms STOP the workout at once.
CONSULT A PHYSICIAN IMMEDIATELY.
4. Position the equipment on a clear, level surface. DO NOT use the bench near water or outdoors.
5. Keep hands away from all moving parts.
6. Always wear appropriate workout clothing when exercising. DO NOT wear robes or other clothing that could become caught in the equipment.
7. Use the equipment only for its intended use as described in this manual. DO NOT use attachments not recommended by the manufacturer.
8. Before using the equipment, always do stretching exercises to properly warm up.
9. Never operate the equipment if the equipment is not functioning properly.

Tools Required

Assembly Size : Approx. L1520 x W1200 x H2100MM

Tools Required : Allen Wrench Set / Socket Wrench Set

Adjustable Wrench / Crescent Wrench

Rubber Mallet / Tape Measure

ASSEMBLY REQUIRES AT LEAST TWO PERSONS

Weight Capacity

Maximum Weight of the Weight : **600LBS**

WARNING: This Product Is Rated for Home Use Only!

Using this product in a commercial setting will void all warranties and can result in serious injury or death!

Assembly Instructions

STEP 1

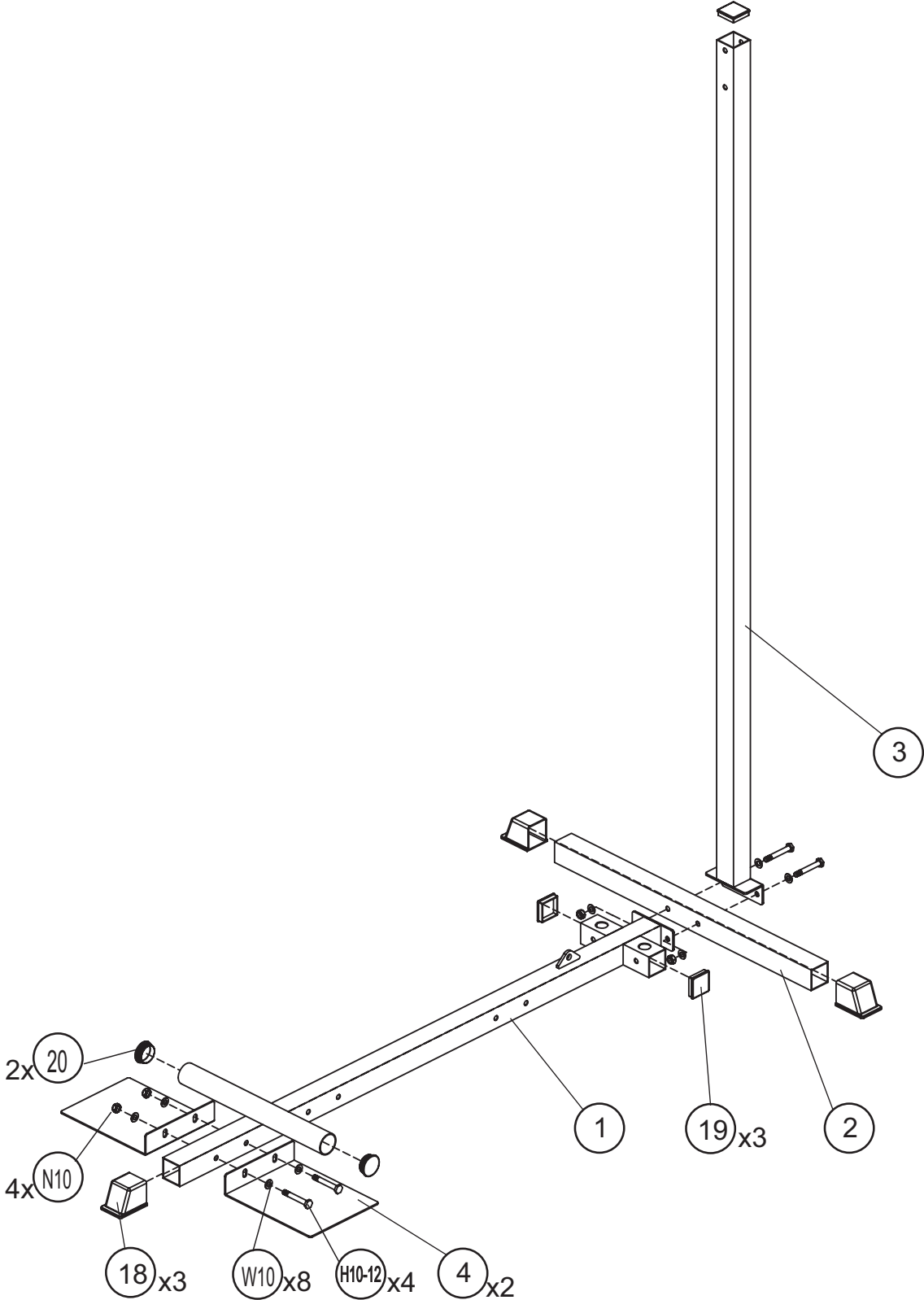

Assembly Instructions

STEP 2

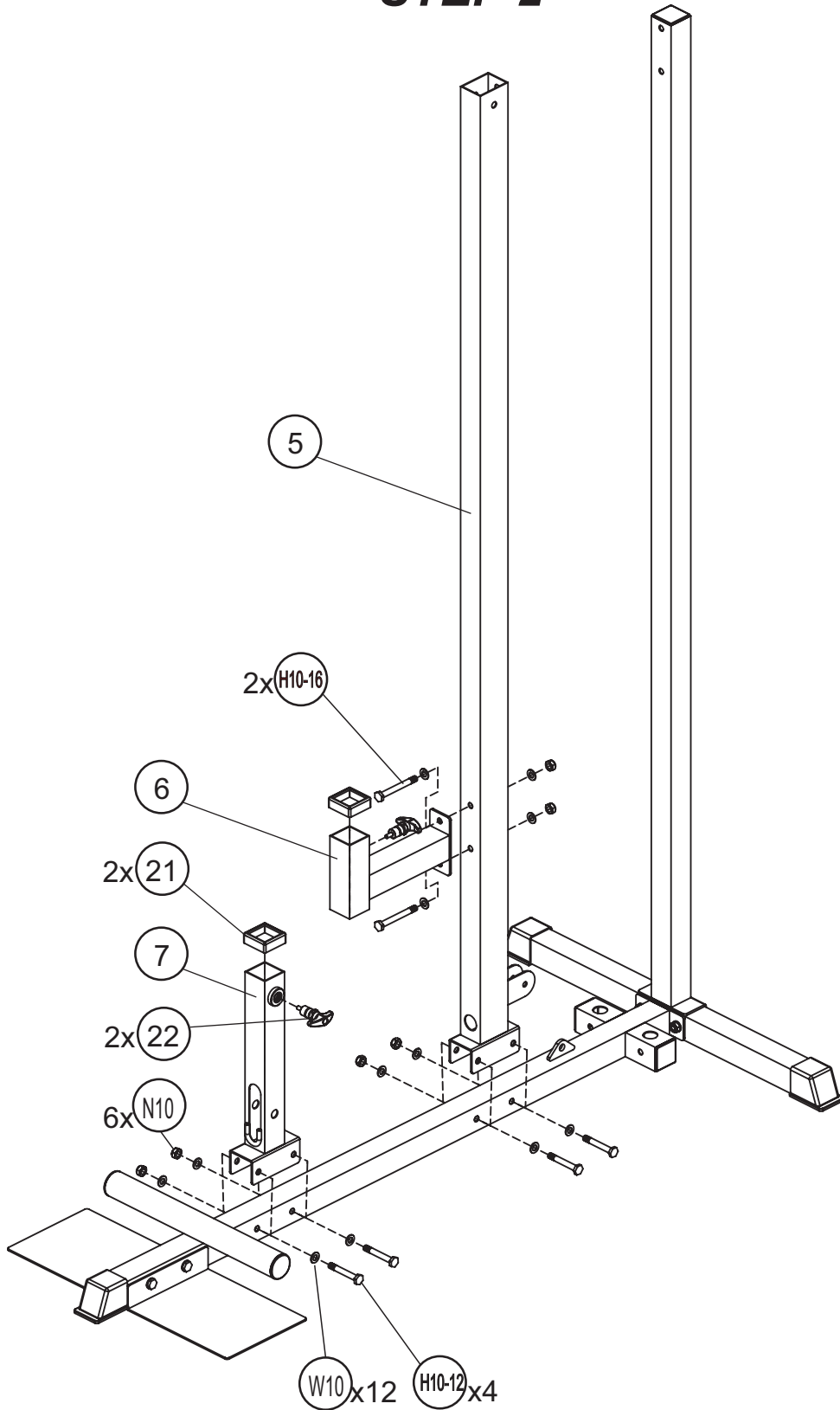

Assembly Instructions

STEP 3

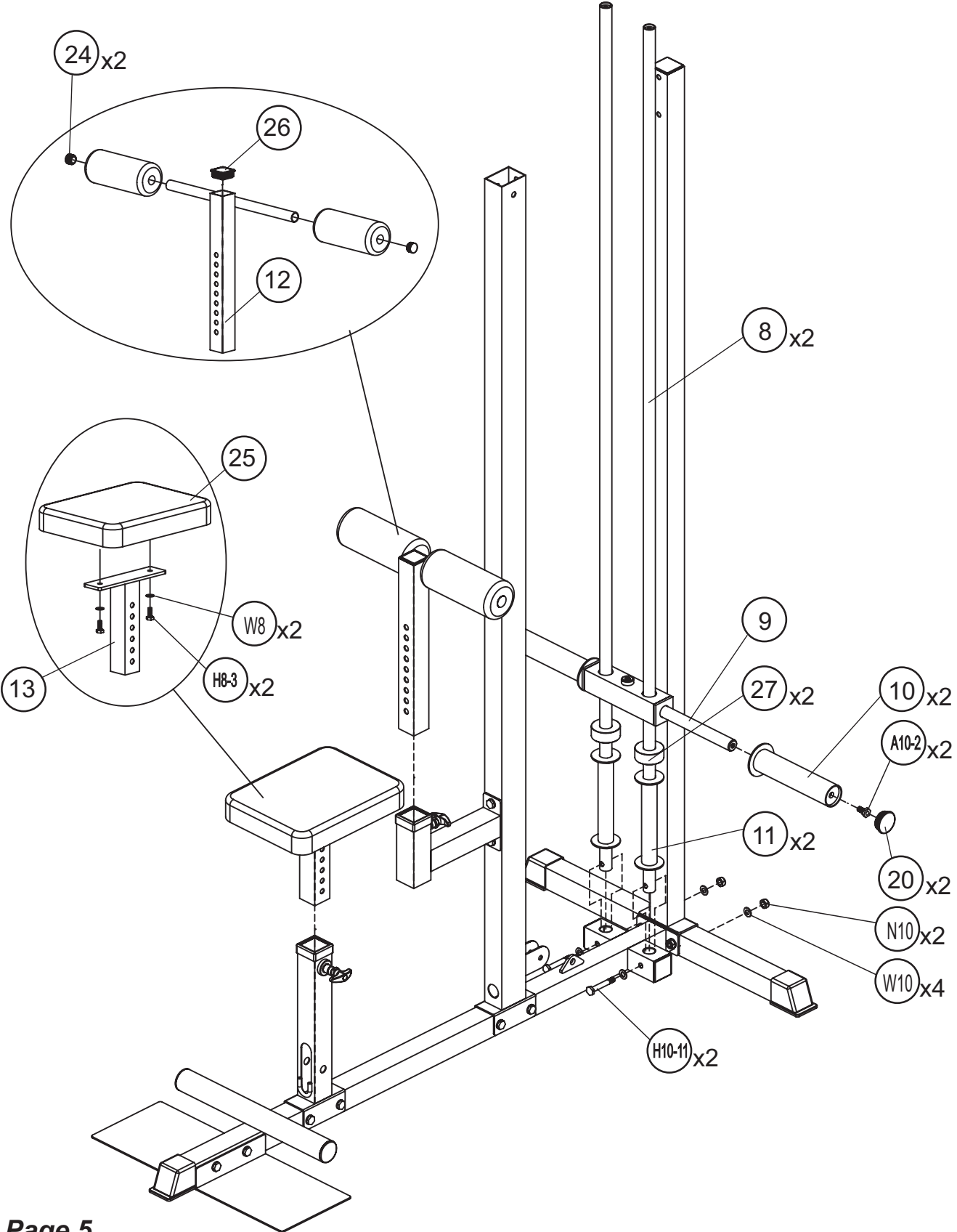

Assembly Instructions

STEP 4

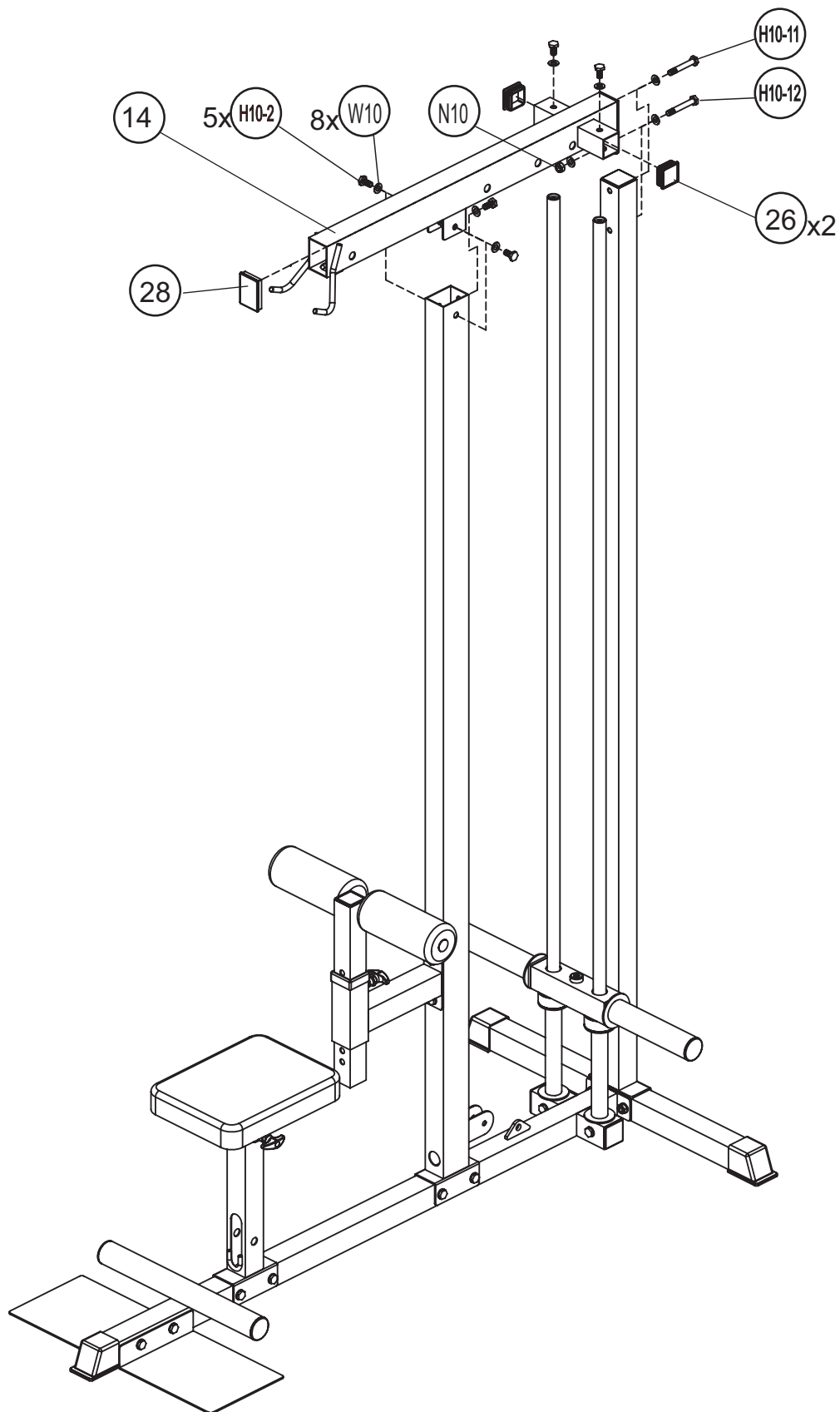

Assembly Instructions

Cable Loop Diagram

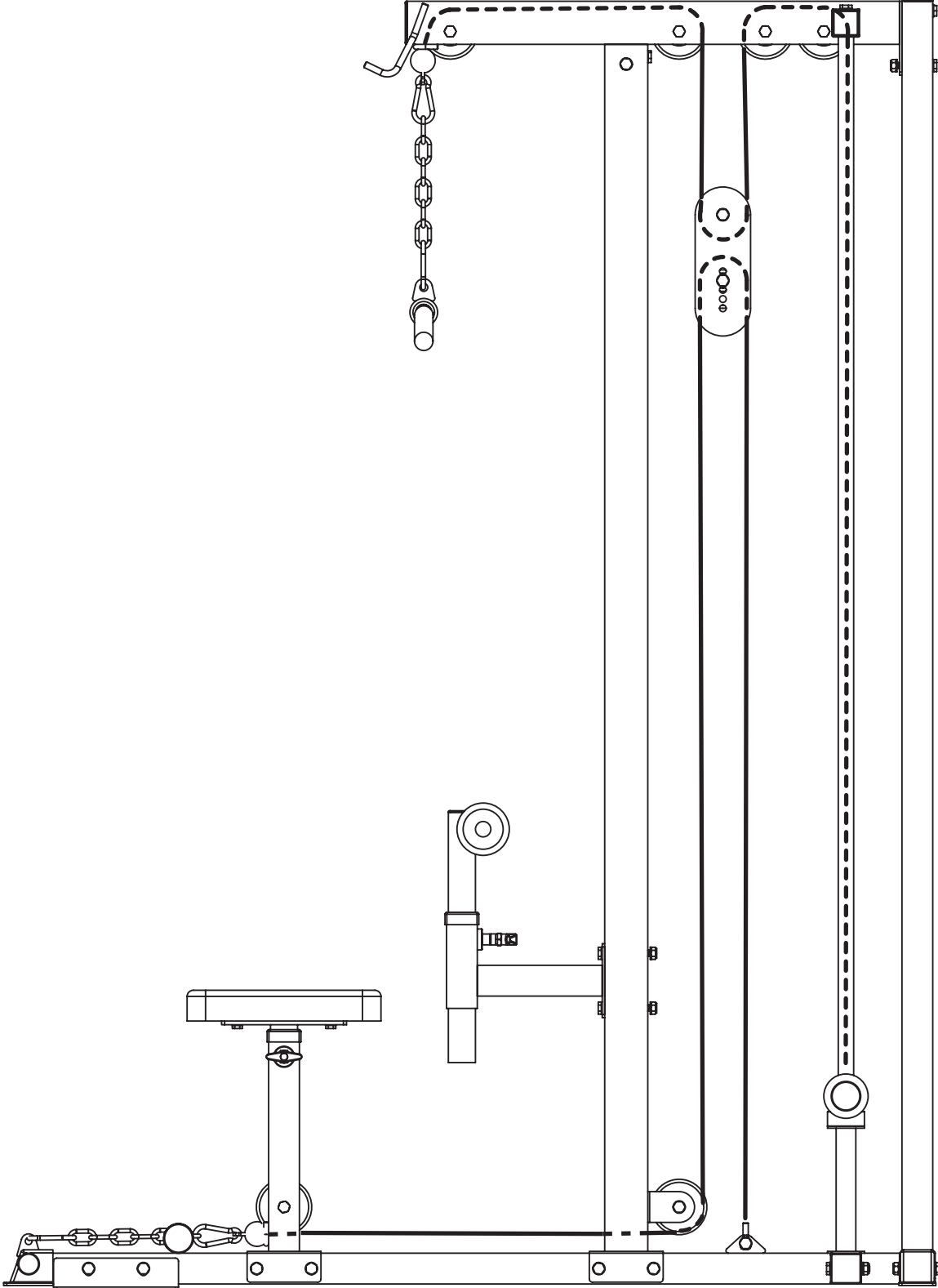

Assembly Instructions

STEP 5

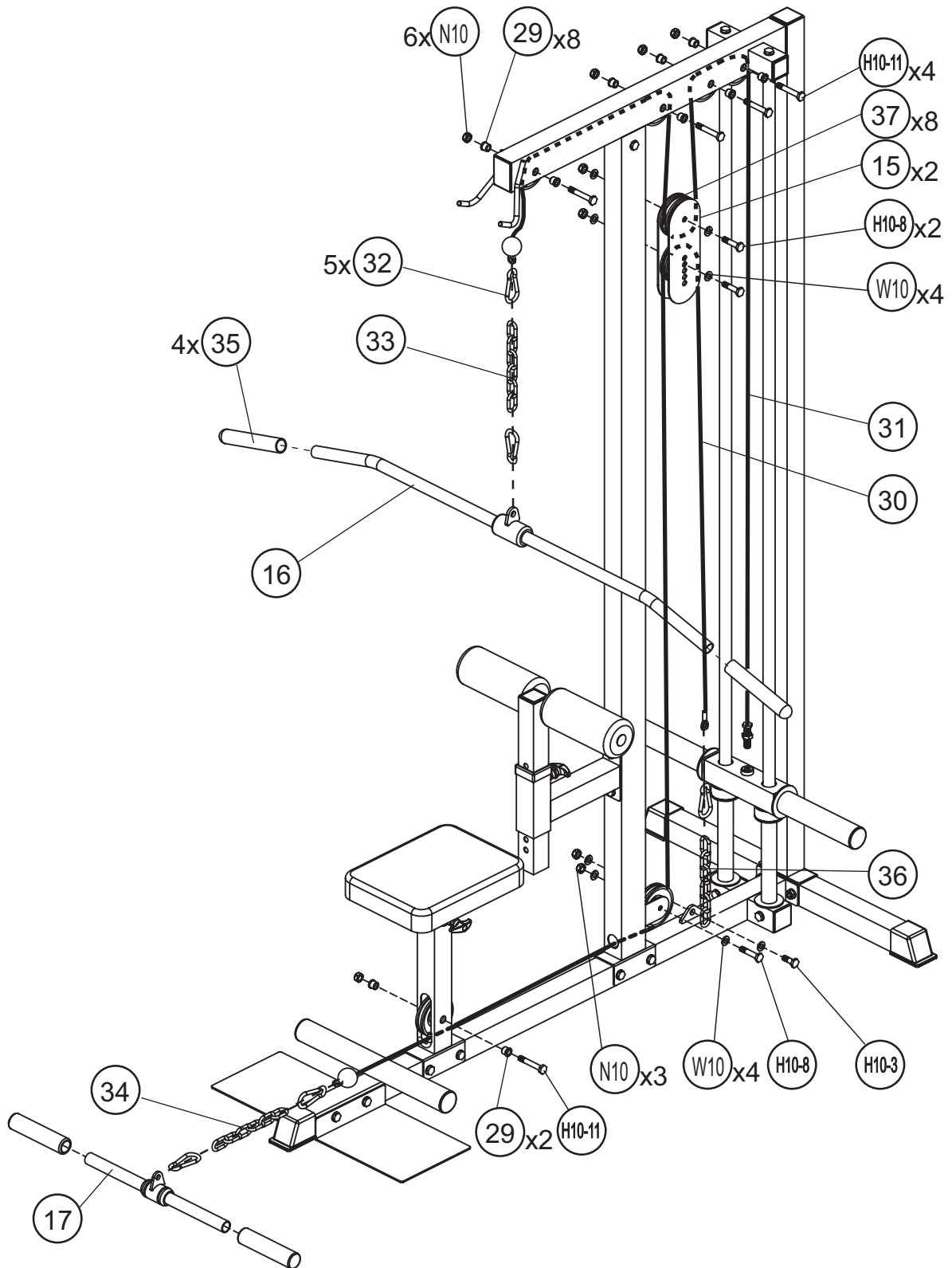

Assembly Instructions

Parts & Hardware List

Part#	Description	Qty	Remark
1	Bottom Frame	1	
2	Rear Foot Tube	1	
3	Rear Upright	1	
4	Foot Plate	2	
5	Front Upright	1	
6	Leg Holder Bracket	1	
7	Seat Bracket Support	1	
8	Guide Rod	2	
9	Weight Plate Holder	1	
10	Olympic Sleeve	2	
11	Plate Holder Riser	2	
12	Leg Holder	1	
13	Seat Bracket	1	
14	Top Frame	1	
15	Pulley Plate	2	
16	Lat Bar	1	
17	Low Row Bar	1	
18	F50x50mm Outer Cap	3	
19	F50x50mm Inner Cap	3	Pre-assembled
20	Dia 48mm Inner Cap	4	Pre-assembled
21	F50-45mm Sleeve	2	Pre-assembled
22	Pop Pin	2	
23	Foam Roller	2	
24	Dia 25mm Inner Cap	2	Pre-assembled
25	Seat Pad	1	
26	F45x45mm Inner Cap	3	Pre-assembled
27	Rubber Bumper	2	
28	F50x70mm Inner Cap	1	Pre-assembled
29	Pulley Bushing	10	
30	Low Row Cable	1	
31	Lat Cable	1	
32	Clip	5	
33	Short Chain	1	
34	Long Chain	1	
35	Handle Sleeve	4	Pre-assembled
36	Cable Chain	1	
37	Pylley	8	

Assembly Instructions

Parts & Hardware List

Part#	Description	Qty	Remark
H8-3	M8x25mm Hex Head Bolt	2	
A10-2	M10x20mm Allen Bolt	2	
H10-2	M10x20mm Hex Head Bolt	5	
H10-3	M10x25mm Hex Head Bolt	1	
H10-8	M10x50mm Hex Head Bolt	3	
H10-11	M10x65mm Hex Head Bolt	8	
H10-12	M10x70mm Hex Head Bolt	9	
H10-16	M10x90mm Hex Head Bolt	2	
W8	M8 Washer	2	
W10	M10 Washer	40	
N10	M10 Nut	22	