

## OVERVIEW CHART

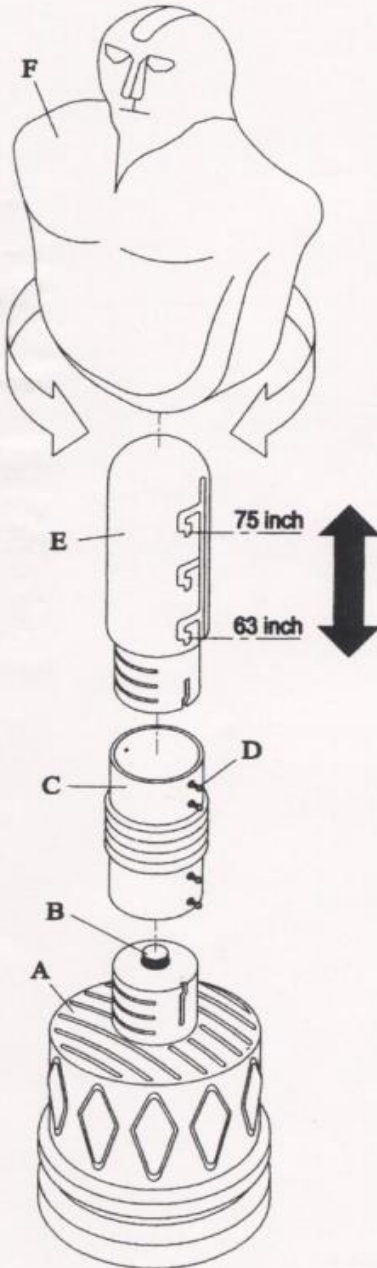

## HEAVY TRAINING BOXING AID ASSEMBLY INSTRUCTIONS

### FEATURE:

1. Free standing, no chains or hanger required.
2. Water-filled base provides excellent stability.
3. Pressurized bag stem for optimal resistance.
4. Flexible polyurethane construction allows for quick rebound.

### INSTRUCTIONS

**Step 1.** Open the Cap (B) on the Base (A) fills the Base (A) with Water or Sand.

Then close the Cap (B) as shown in Figure A & Figure B.

**Step 2.** Attach Elasticity (C) to the Base (A), and tighten them with eight Bolts (D) and attach stretch form (E) to Elasticity (C) with same way as shown in Overview Chart.

**Step 3.** You can adjust the PU Man (F) from 63" to 75" by the direction on the Overview Chart.

**Step 4.** If you want to release the water, just open the cap (on the top of the Base). You can fill the base with sand or water

Water 110kgs.

Sand 130kgs.

※ Do not use Boxing stand by the hand with other things. (ex: Ring)

※ Do not use Boxing stand by the Sports shoes or Boxing shoes with other things.

FIGURE A



FIGURE B

