

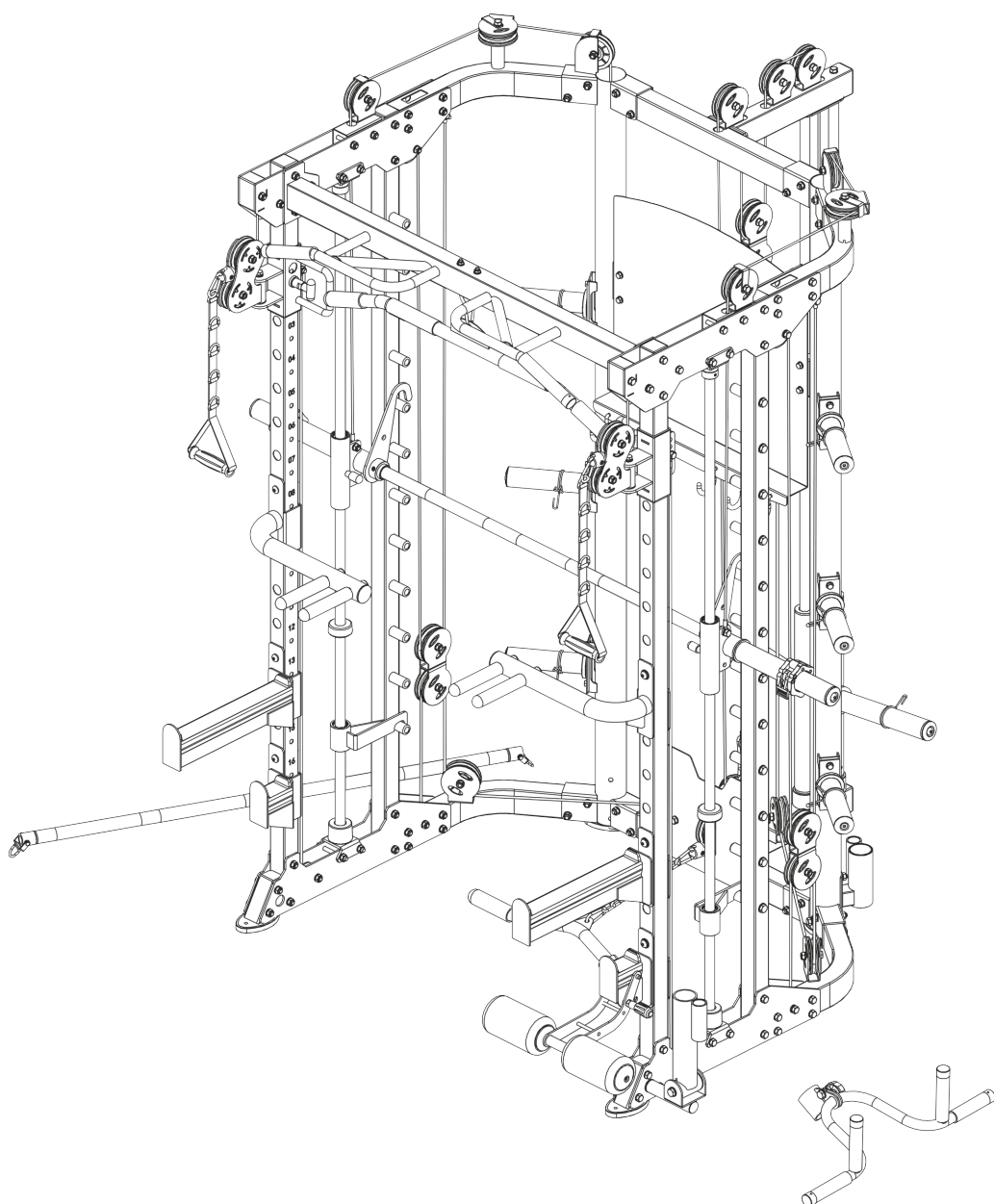





Assembly and Operating Instructions



 ~ 300 Min. 

 199 kg
L 148 | W 202 | H 224

SEBR2720.01.01

SKU: SEBR2720

BodyMax CTX5

Content

1	GENERAL INFORMATION	7
1.1	Technical Data	7
1.2	Personal Safety	8
1.3	Set-Up Place	9
2	ASSEMBLY	10
2.1	General Instructions	10
2.2	Scope of Delivery	10
2.3	Assembly	15
2.4	Optional Leg Press Plate	40
2.4.1	Scope of Delivery - Leg Press Plate	40
2.4.2	Assembly - Leg Press Plate	40
3	STORAGE AND TRANSPORT	41
3.1	General Instructions	41
4	TROUBLESHOOTING, CARE AND MAINTENANCE	42
4.1	General Instructions	42
4.2	Faults and Fault Diagnosis	42
4.3	Maintenance and Inspection Calendar	43
5	DISPOSAL	43
6	RECOMMENDED ACCESSORIES	44
7	ORDERING SPARE PARTS	45
7.1	Serial Number and Model Name	45
7.2	Parts List	46
7.3	Exploded Drawing	49
8	WARRANTY	50
9	CONTACT	52

Dear customer,

Thank you for choosing training equipment from BodyMax.

BodyMax is your reliable partner for home and commercial gym equipment. We are specialized in cardio and strength training machines for home and commercial use. Our products are not only strong, durable, and affordable but also designed to fit your personal needs.

The BodyMax headquarter is based in Rutherglen, Glasgow. Our brand was created with the intention of providing innovative exercise equipment at affordable prices for users of all training levels.

You can find further information at www.bodymax-fitness.com.

Intended Use

The equipment may only be used for its intended purpose.

The equipment is only suitable for home use. The equipment is not suitable for semi-professional (e.g. hospitals, associations, hotels, schools, etc.) and commercial or professional use (e.g. fitness studios).

Disclaimer



©2016 BodyMax® is a registered brand of the company Sport-Tiedje GmbH. All rights reserved. Any use of this trademark without the explicit written permission of Sport-Tiedje is prohibited.

Product and manual are subject to change. Technical data can be changed without advance notice.

ABOUT THIS MANUAL

Please carefully read the entire manual before installation and first use. The manual will help you to quickly set up the system and explains how to safely use it. Make sure that all persons exercising with the equipment (especially children and persons with physical, sensory, mental or motor disabilities) are informed about this manual and its contents in advance. In case of doubt, responsible persons must supervise the use of the equipment.

Due to ongoing changes and software optimisations, the manual may have to be updated. If you notice any discrepancies during assembly or use, please refer to the manual uploaded to the webshop. The latest manual is always available there.

This equipment has been manufactured according to the latest safety knowledge. As far as possible, potential safety hazards which could cause injury have been eliminated. Make sure to carefully follow the instructions and that all parts are securely in place. If required, read through the instructions again to correct any mistakes.



Please pay close attention to the safety and maintenance instructions given here. The contract partner cannot be held liable for damage to health, accidents or damage to the equipment when it is not used in accordance with these instructions.

The following safety instructions may appear in this manual:

► **ATTENTION**

This notice indicates potentially hazardous situations which, if not avoided, may result in property damage.

⚠ **CAUTION**

This notice indicates potentially hazardous situations which, if not avoided, may result in slight or minor injuries!

⚠ **WARNING**

This notice indicates potentially hazardous situations which, if not avoided, may result in death or serious injuries!

⚠ **DANGER**

This notice indicates potentially hazardous situations which, if not avoided, will result in death or serious injuries!

ⓘ **NOTICE**

This notice indicates further useful information.

Retain these instructions in a safe place for future reference, maintenance or when ordering replacement parts.

1.1 Technical Data

Weight and Dimensions

Packaging dimensions (L x W x H) approx.:	221 cm x 95 cm x 38 cm
Set-up dimensions (L x W x H) approx.:	148 cm x 202 cm x 224 cm
Article weight (gross, incl. packaging) approx.:	219 kg/482 lbs
Article weight (net, excl. packaging) approx.:	199 kg/438 lbs
Maximum load:	215 kg/474 lbs
Maximum user weight (dip/chin up bars):	150 kg/331 lbs
Cable length:	247.5 cm ; 474 cm ; 409.5 cm ; 170.5 cm ; 971.5 cm
Cable width:	0.5 cm
Cable material:	Steel
Cover material:	Nylon
Pulley diameter:	95 mm ; 50 mm
Transmission ratio:	2:1 & 1:1

Optional Leg Press Plate

Packaging dimensions (L x W x H) approx.:	122 cm x 38 cm x 14 cm
Set-up dimensions (L x W x H) approx.:	113 cm x 34 cm x 13 cm
Article weight (gross, incl. packaging) approx.:	12 kg/26 lbs
Article weight (net, excl. packaging) approx.:	11 kg/24 lbs

1.2 Personal Safety

DANGER

- + Before you start using the equipment, you should consult your physician that this type of exercise is suitable for you from a health perspective. Particularly affected are persons who: have a hereditary disposition to high blood pressure or heart disease, are over the age of 45, smoke, have high cholesterol values, are overweight and/or have not exercised regularly in the past year. If you are under medical treatment that affects your heart rate, medical advice is absolutely essential.
- + Note that excessive training can seriously endanger your health. Please also note that heart rate monitoring systems can be inaccurate. If you notice any signs of weakness, nausea, dizziness, pain, shortness of breath, or other abnormal symptoms, stop exercising immediately and seek advice from your doctor if necessary.

WARNING

- + This equipment may not be used by children under the age of 14.
- + Children should not be allowed unsupervised access to the equipment.
- + Persons with disabilities must have a medical license and must be under strict observation when using the equipment.
- + The equipment is strictly for use by one person at a time.
- + If your equipment provides a safety key, the clip of the safety key must be attached to your clothing before starting your training. In the event of a fall, the EMERGENCY STOP of the equipment can be initiated.
- + Keep your hands, feet and other body parts, hair, clothing, jewellery and other objects well clear of moving parts.
- + During use, wear suitable sports clothing rather than loose or baggy clothing. When wearing sports shoes, make sure they have suitable soles, preferably made of rubber or other non-slip materials. Shoes with heels, leather soles, studs or spikes are unsuitable. Never exercise barefoot.

CAUTION

- + If your equipment needs to be connected to the power supply with a mains cable, make sure that the cable is not a potential tripping hazard.
- + Make sure that nobody is within the range of motion of the equipment during training so as not to endanger you or other persons.

ATTENTION

- + Do not insert any objects of any kind into the openings of the device.

1.3 Set-Up Place

WARNING

- + Do not place the equipment in main corridors or escape routes.

CAUTION

- + Choose a location in which to place the equipment such that there is enough free space/clearance to the front, the rear and to the sides of the equipment.
- + The training room should be well ventilated during training and not be exposed to any draughts.
- + Choose the place in which to set up the equipment such that there is enough free space/clearance to the front, the rear and to the sides of the equipment.
- + The set-up and mounting surface of the equipment should be flat, loadable and solid.
- + If your device is to be mounted on the wall/ceiling, make sure that you use the appropriate assembly material to avoid possible damages or personal injuries. The contractual partner accepts no liability for this.

ATTENTION

- + The device may only be used in one building, in sufficiently tempered and dry rooms (ambient temperatures between 10°C and 35°C). The equipment should not be used outdoors or in rooms with high humidity (over 70%) like swimming pools.
- + A floor protective mat/equipment underlay can help to protect high-quality floor coverings (parquet, laminate, cork, carpets) from dents and sweat and can help to level out slight unevenness.

2.1 General Instructions



DANGER

- + Do not leave any tools, packaging materials such as foils or small parts lying around, as otherwise there is a danger of suffocation for children. Keep children away from the equipment during assembly.



WARNING

- + Pay attention to the instructions attached to the equipment in order to reduce the risk of injuries.



CAUTION

- + Ensure to have sufficient room for movement in each direction during assembly.
- + The assembly of the equipment must be carried out by at least two adults. If in doubt, seek the help of a third technically skilled person.



ATTENTION

- + To prevent damage to the equipment and the floor, assemble the equipment on a mat or packaging board.



NOTICE

- + In order to make the assembly as simple as possible, some screws and nuts to be used can already be pre-assembled.
- + Ideally, assemble the equipment at its later set-up place.

2.2 Scope of Delivery

The scope of delivery consist of the following parts. At the beginning, check whether all parts and tools belonging to the device are included in the scope of delivery and whether damage has occurred. In the event of complaints, the contractual partner must be contacted directly.



CAUTION

- If parts of the scope of delivery are missing or damaged, the assembly must not be carried out.

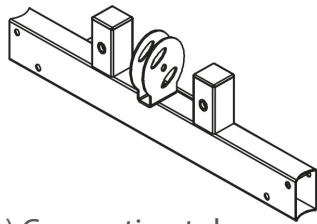

(1) Connection tube

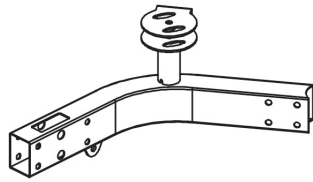

(8) Upper bending tube left

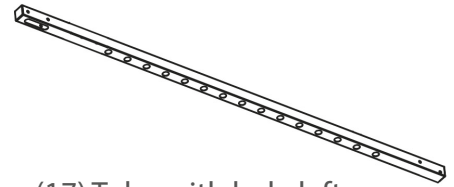

(17) Tube with hole left

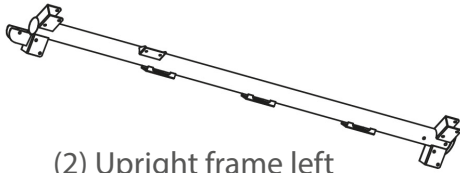

(2) Upright frame left

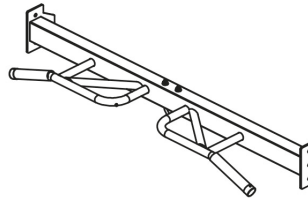

(12) Chin up bar

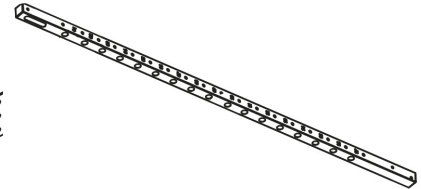

(18) Tube with hole right

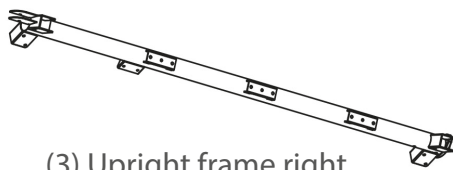

(3) Upright frame right

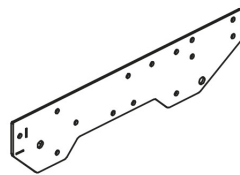

(13) Upper plate 4x

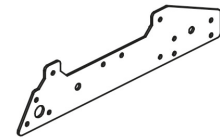

(19) Lower plate 4x

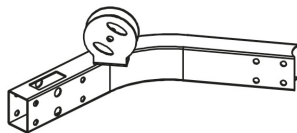

(4) Bending tube left

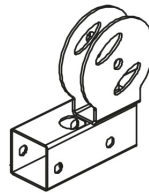

(14) Pulley frame tube right

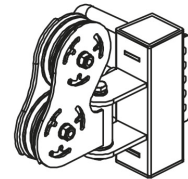

(20) Sliding tube right

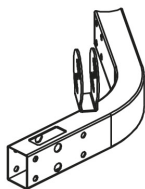

(5) Bending tube right



(15) Pulley frame tube left

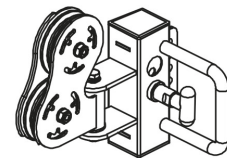

(21) Sliding tube left

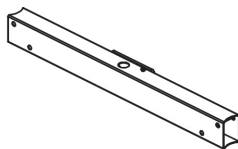

(6) Upper connection tube

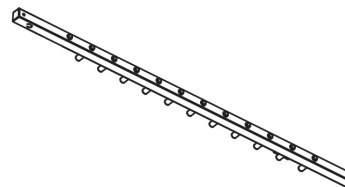

(16) Upright tube 2x



(22) Foot tube cover 2x

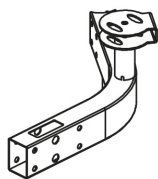

(7) Upper bending tube right



(23) End tube 2x

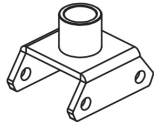

(25) Lower base 2x



(36) Check ring 2x

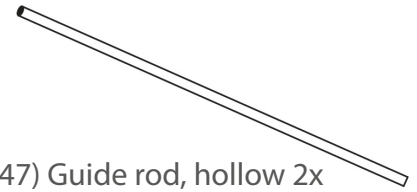

(47) Guide rod, hollow 2x

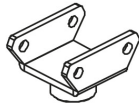

(26) Upper base 2x

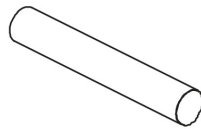

(37) Pipe 2x

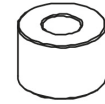

(48) Rubber pad 2x

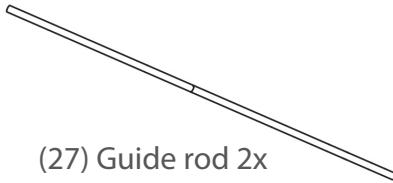

(27) Guide rod 2x

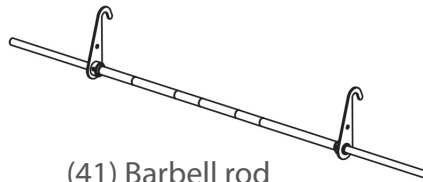

(41) Barbell rod

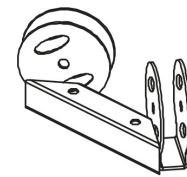

(53) Double pulley bracket



(28) Lock sleeve 2x

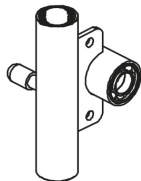

(29) Sliding sleeve 2x



(43) Rubber pad 2x

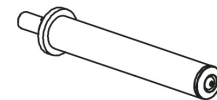

(55) Back barbell plate holder 2x



(30) Rubber pad with groove 2x

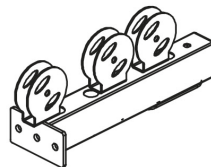

(44) Upper connection tube short



(56) Wire - 2745mm 2x

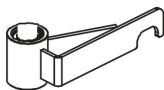

(31) Safety hook right

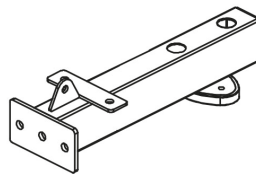

(45) Lower connection tube



(57) Pulley - 95mm 25x



(32) Safety hook left

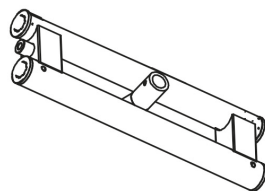

(46) Big sliding sleeve



(35) End cap 2x

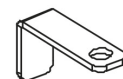

(58) Pulley plate 6x



(61) Weight 2x



(62) Wire - 4740mm



(63) Hanging pulley frame 3x

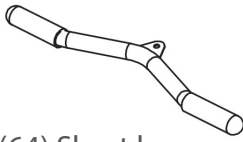

(64) Short bar



(65) Foot plate



(66) Chain with snap hooks

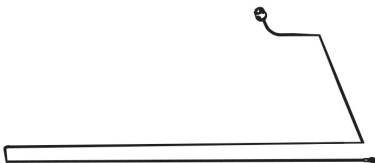

(67) Wire - 4185mm 2x



(68) Pulley spacer sleeve 16x

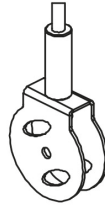

(69) Pulley frame



(70) Wire - 1705mm



(71) 5section chain with snap hooks

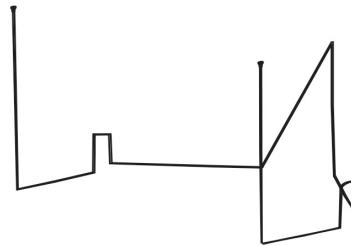

(72) Wire - 9715mm



(73) Pulley - 50mm 4x

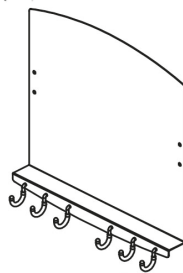

(74) Shield



(76) Barbell plate holder 6x

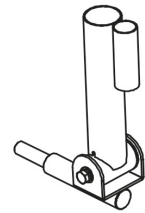

(79) Core trainer



(80) Powder metallurgy sleeve 2x

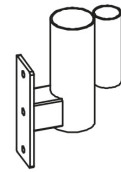

(81) Barbell rod cup

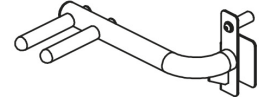

(83) Dip bar left

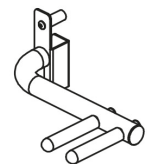

(84) Dip bar right

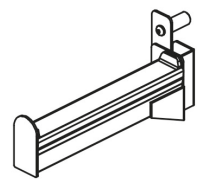

(85) Barbell rod holder right

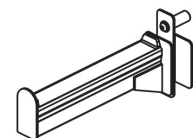

(86) Barbell rod holder left



(87) Barbell rod holder short left

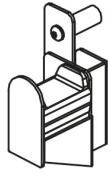

(88) Barbell rod holder short right

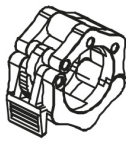

(89) Barbell clamp collar 2x



(90) Long bar



(91) Ship rod

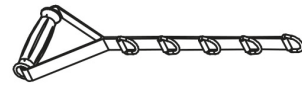

(92) Hand belt 2x

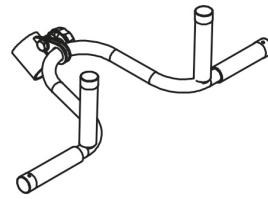

(93) Pull lift device

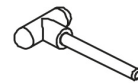

(94) T-shaped pin

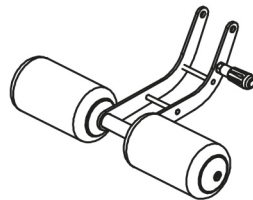

(95) Leg curl tube

2.3 Assembly

Before assembly, take a close look at the individual assembly steps shown and carry out the assembly in the order given.

① NOTICE

- + First loosely screw all parts together and check that they fit properly. Tighten the screws using the tool only when you are instructed to do so.
- + If you have difficulty recognising the graphics, we recommend that you open and/or download the PDF instructions stored in the webshop on your end device (e.g. smartphone, tablet or PC). There you have the option of zooming in closer. Please note that the Adobe Acrobat Reader programme must be installed on your end device in order to open the file.

Step 1: Assembly of the Main Frame

① NOTICE

- + Install all bolts and nuts before tightening. Do not over tighten.
 - + Not all bolts, washers and nuts are shown in the drawing as they are identical. For each bolt connection, use one bolt (9), two washers (11) and one nut (10).
1. Attach the left bending tube (4) to the bottom of left upright frame (2) with two bolts (9), four washers (11) and two nuts (10).
 2. Attach the right bending tube (5) to the bottom of right upright frame (3) with two bolts (9), four washers (11) and two nuts (10).
 3. Attach the connection tube (1) to the bottom of the left and right upright frames (2 & 3) with a total of four bolts (9), eight washers (11) and four nuts (10).
 4. Attach the upper connection tube (6) to the top of the left and right upright frames (2 & 3) with a total of four bolts (9), eight washers (11) and four nuts (10).
 5. Attach the left upper bending tube (8) to the top of the left upright frame (2) with two bolts (9), four washers (11) and two nuts (10).
 6. Attach the right upper bending tube (7) to the top of the right upright frame (3) with two bolts (9), four washers (11) and two nuts (10).
 7. Tighten bolts and nuts.

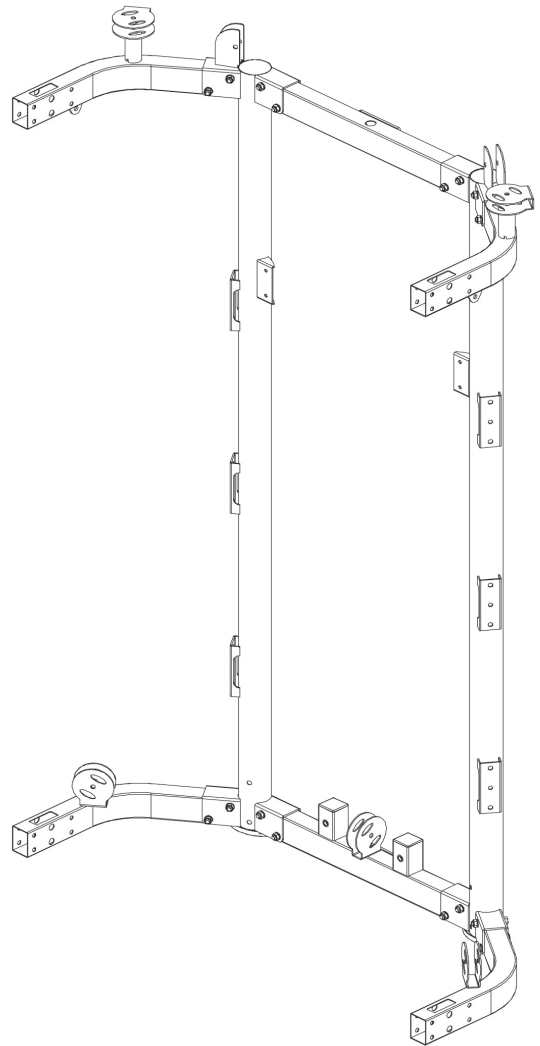

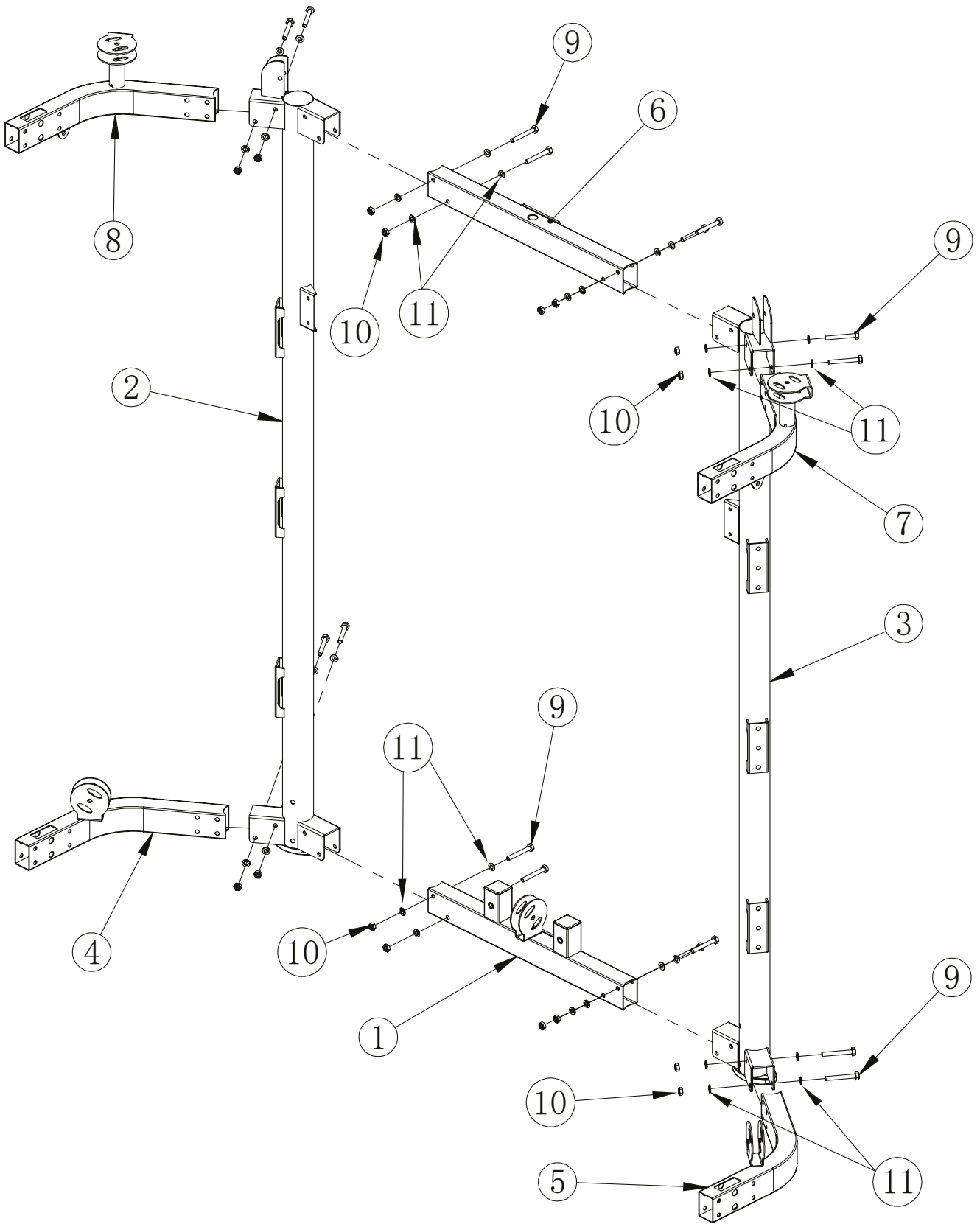

Step 2: Assembly of the Tubes and Chin Up Bar, Part 1

NOTICE

+ Install all bolts and nuts before tightening. Do not over tighten.

1. Attach one upright tube (16) together with two upper plates (13) to the right upper bending tube (7) with two bolts (9), four washers (11) and two nuts (10).
2. Attach the upright tube (16) together with two lower plates (19) to the right bending tube (5) with two bolts (9), four washers (11) and two nuts (10).
3. Attach the right pulley frame tube (14) to the upper plates (13) with two bolts (9), four washers (11) and two nuts (10) [fig. A].
4. Attach the upper plates (13) to the right upper bending tube (7) with four bolts (9), eight washers (11) and four nuts (10) [fig. B].
5. Attach the right sliding tube (20) to the right tube with holes (17).
6. Attach the right tube with holes (17) and the foot tube cover (22) to the lower plates (19) with four bolts (9), eight washers (11) and four nuts (10) [fig. C].
7. Attach the lower plates (19) to the right bending tube (5) with four bolts (9), eight washers (11) and four nuts (10) [fig. D].
8. Repeat the steps 1 to 7 on the left side.

NOTICE

+ For the left side, use the left pulley frame tube (15), left sliding tube (21) and left tube with holes (18).

+ Do not tighten bolts and nuts yet.

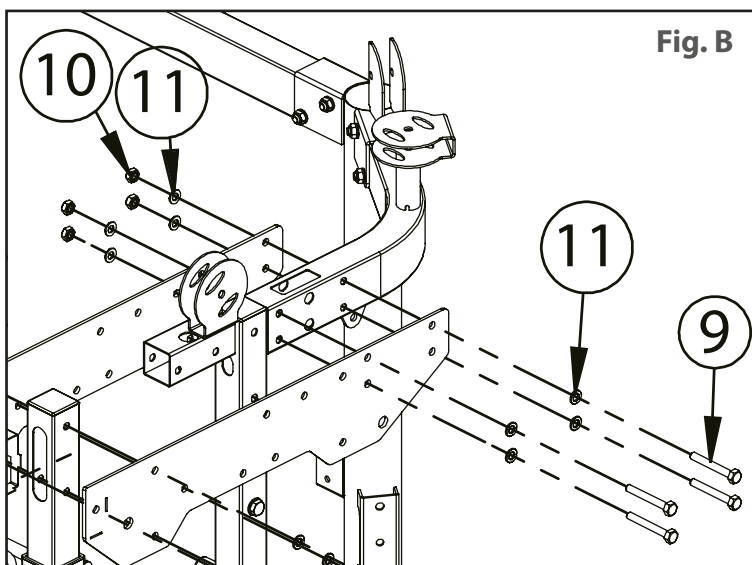
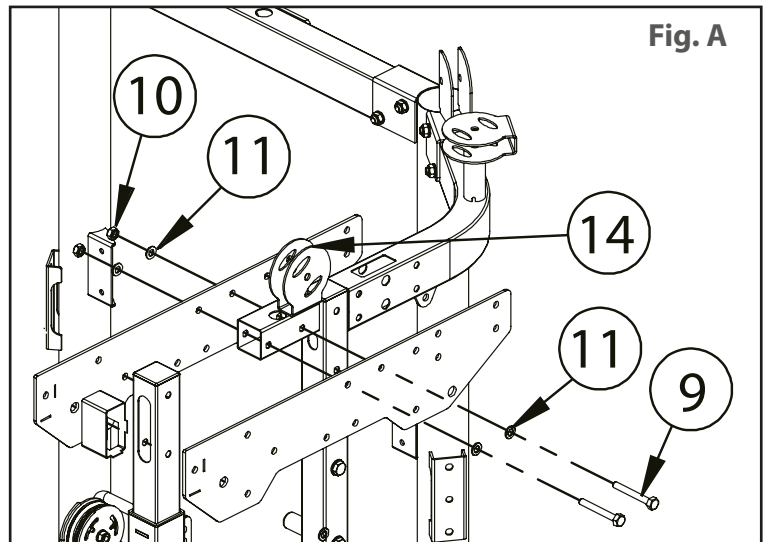

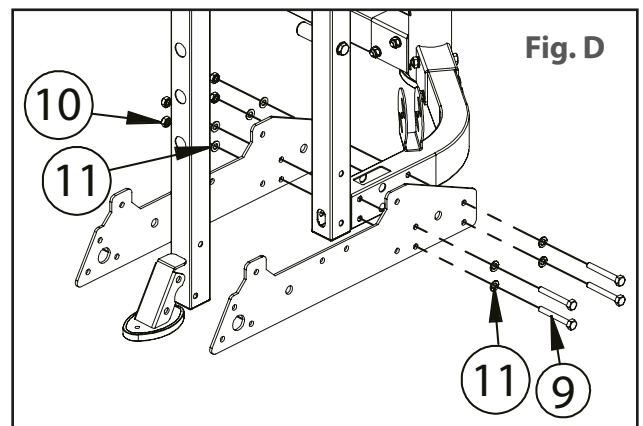
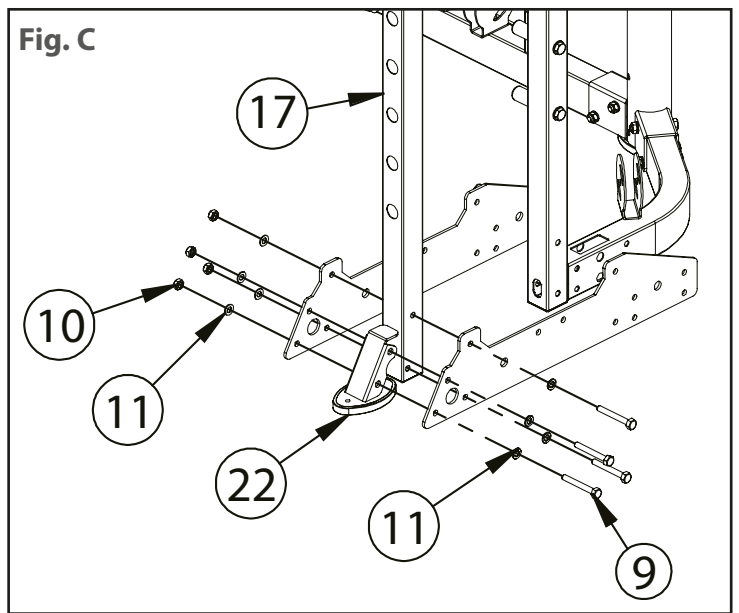
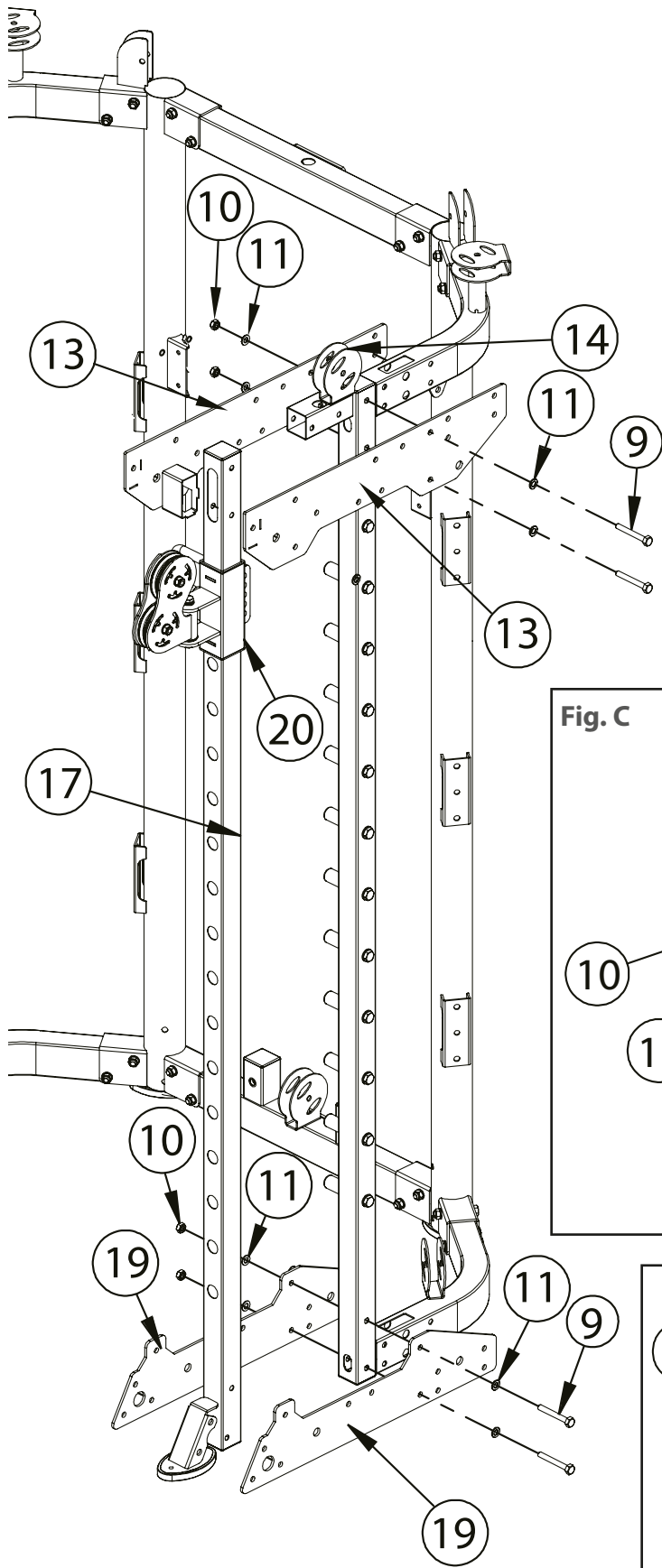

Step 2: Assembly of the Tubes and Chin Up Bar, Part 2

ⓘ NOTICE

+ Install all bolts and nuts before tightening. Do not over tighten.

1. Attach one end tube (23) between the upper plates (13) with one bolt (9), two washers (11) and one nut (10) on each side of the machine.
2. Attach the chin up bar (12) to the inner side of the upper plates (13) and to the left and right tubes with holes (18 & 17) with a total of six bolts (24), twelve washers (11) and six nuts (10).
3. Now tighten all bolts and nuts.

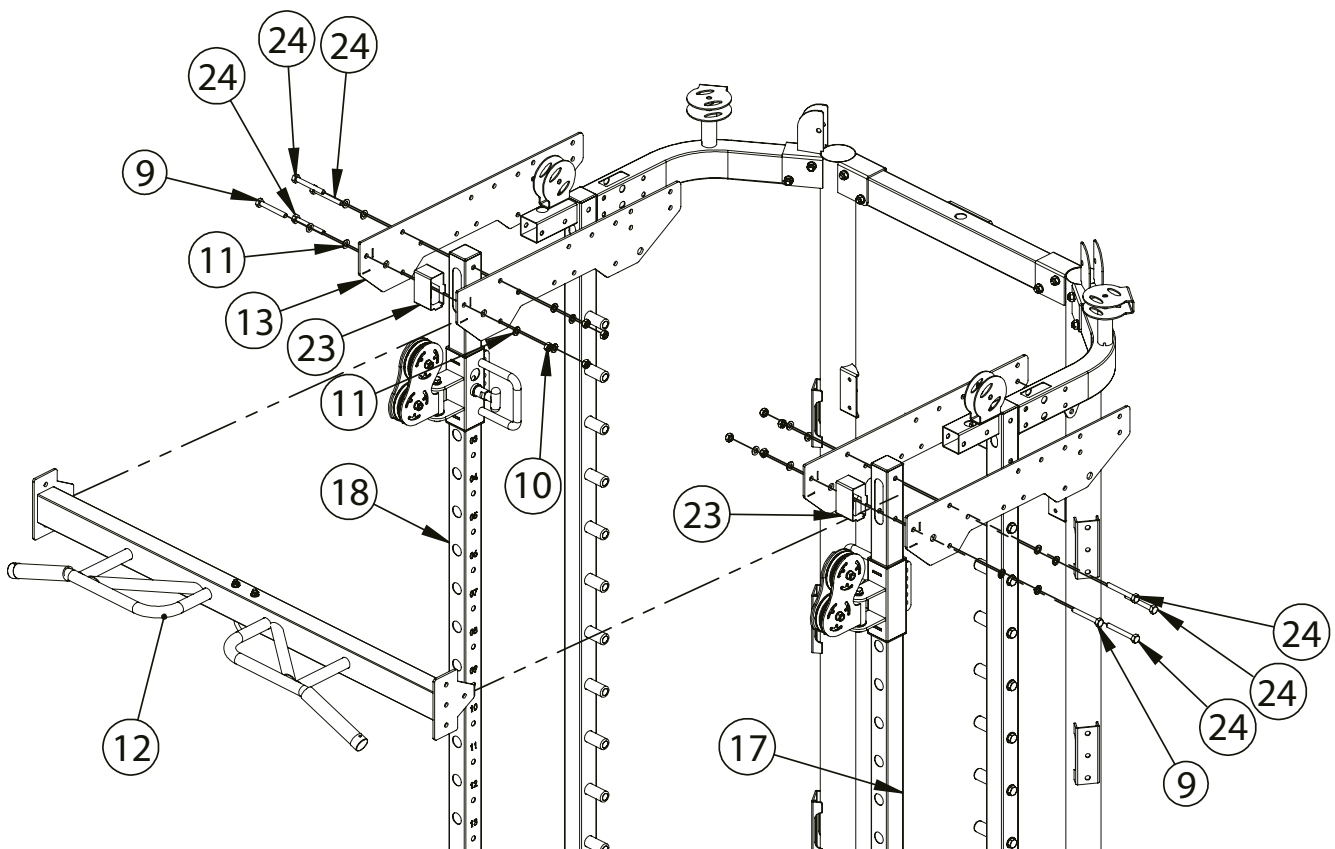

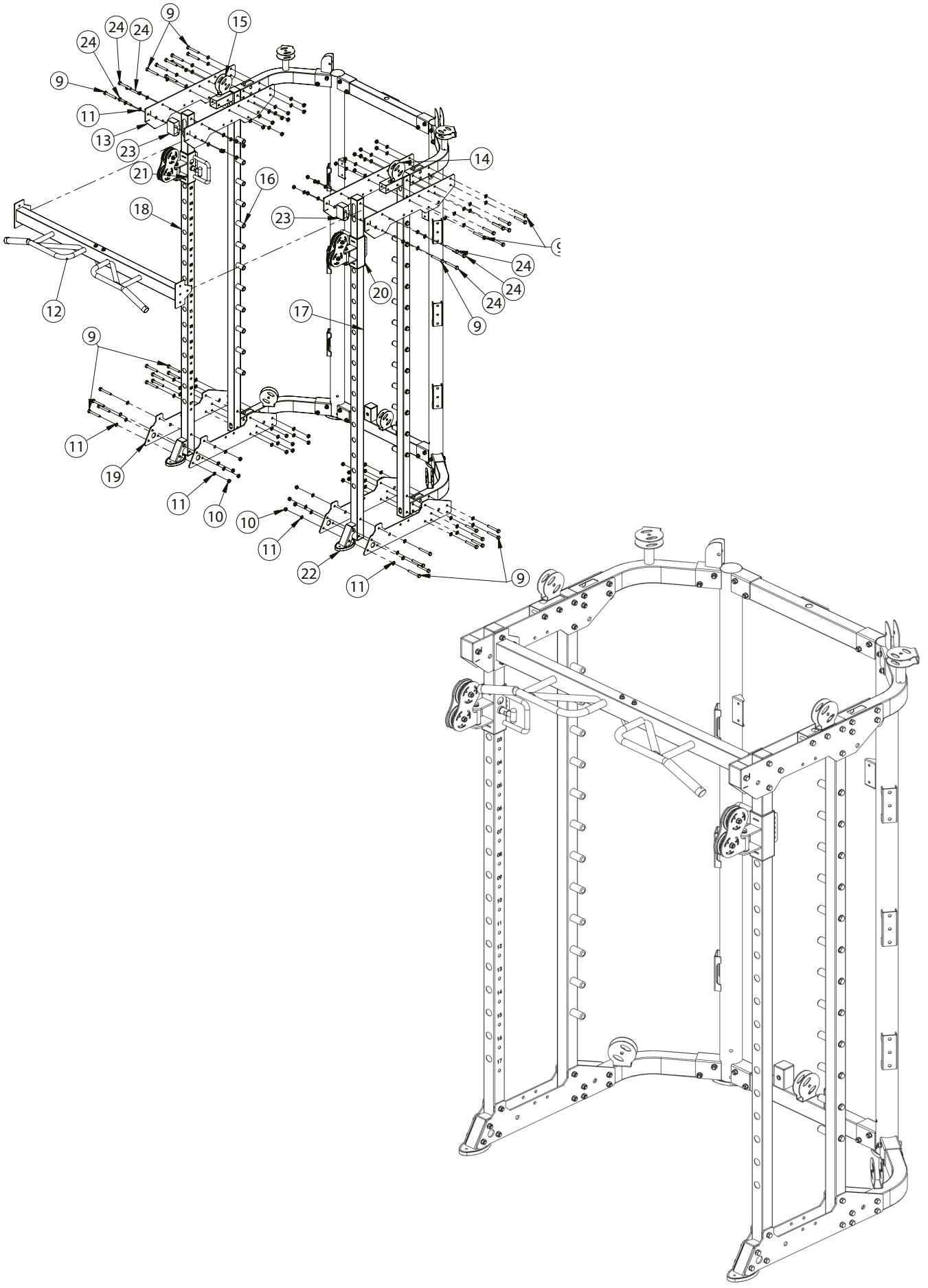

Step 3: Assembly of Guide Rods and Barbell Rod

1. Attach the lower bases (25) to the lower plates (19) with a total of four bolts (33), eight washers (11) and four nuts (10).
2. Attach the upper bases (26) to the upper plates (13) with a total of four bolts (33), eight washers (11) and four nuts (10).

NOTICE

For the next steps, it is recommended to begin on one side and proceed further. The following instructions begin on the right side.

3. Slide the following parts over the right guide rod (27) in the following order: one rubber pad with groove (30), one safety hook left (32; the hook should be facing inwards/to the left), one rubber pad (43), one sliding sleeve (29) and one lock sleeve (28).
4. Slide the following parts over the left guide rod (27) in the following order: one rubber pad with groove (30), one safety hook right (31; the hook should be facing inwards/to the right), one rubber pad (43), one sliding sleeve (29) and one lock sleeve (28).
5. While carefully holding the right guide rod with its components, insert the guide rod (27) into the lower base (25) and upper base (26).
6. Secure the guide rod (27) to the lock sleeve (28) with one set screw (34).
7. First, slide the barbell rod (41) through the right sided sliding sleeve (29) on the right guide rod (27), then hang the barbell rod (41) at any height in the upright tubes (16).
8. While carefully holding the left guide rod and its components, first slide the left sided sliding sleeve (29) onto the left side of the barbell rod (41), then insert the left guide rod (27) into the lower base (25) and upper base (26).
9. Secure the guide rod (27) to the lock sleeve (28) with one set screw (34).
10. Slide one check ring (36) and one pipe (37) onto each end of the barbell rod (41).
11. Attach one end cap (35) to each pipe (37) with one bolt (38), one spring washer (39) and one washer (40).
12. Slide one barbell collar (89) onto each pipe (37).

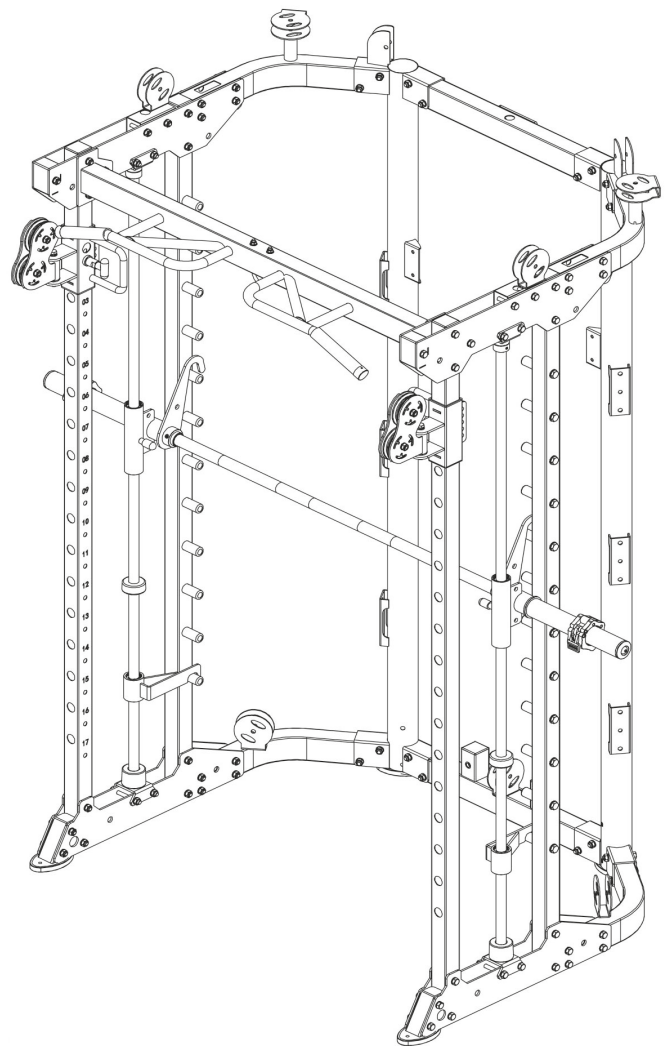

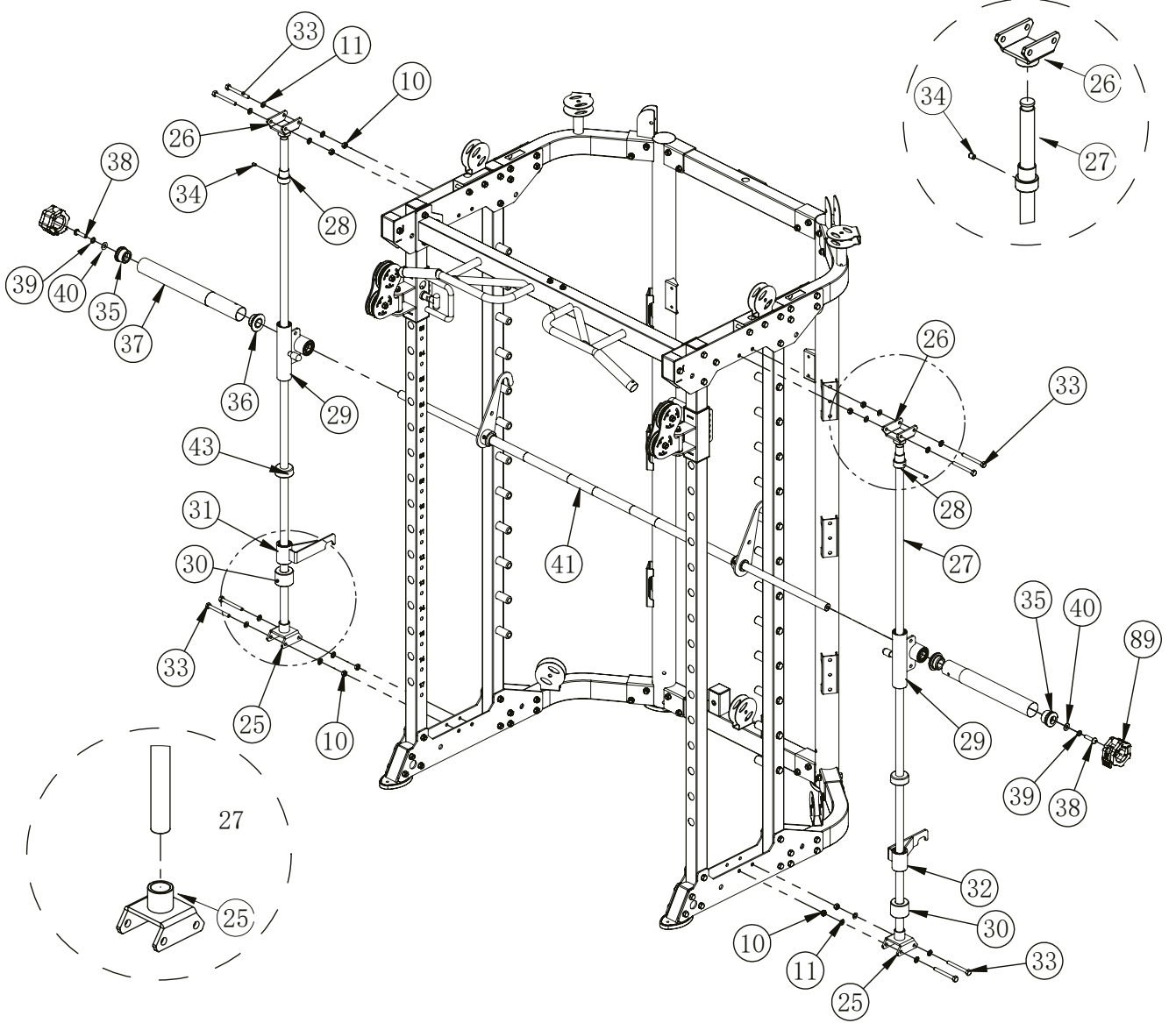

Step 4: Assembly of the Hollow Guide Rods

NOTICE

Install all bolts and nuts before tightening.

1. Attach the short upper connection tube (44) to the upper connection tube (6) with two bolts (52), two spring washers (39) and two washers (40).
2. Attach the lower connection tube (45) to the connection tube (1) with two bolts (52), two spring washers (39) and two washers (40).
3. Attach the double pulley bracket (53) to the lower connection tube (45) with two bolts (51), four washers (11) and two nuts (10).
4. Slide two rubber pads (48) and the big sliding sleeve (46) over the hollow guide rods (47).
5. Insert the guide rods (47) into the lower connection tube (45).
6. Attach the guide rods (47) to the lower connection tube with two bolts (49) and two washers (11).
7. Attach the guide rods (47) to the short upper connection tube (44) with two bolts (50) and two washers (11).
8. Attach the back barbell plate holders (55) to the big sliding sleeve (46) with one set screw (34) each.
9. Tighten the bolts and nuts.

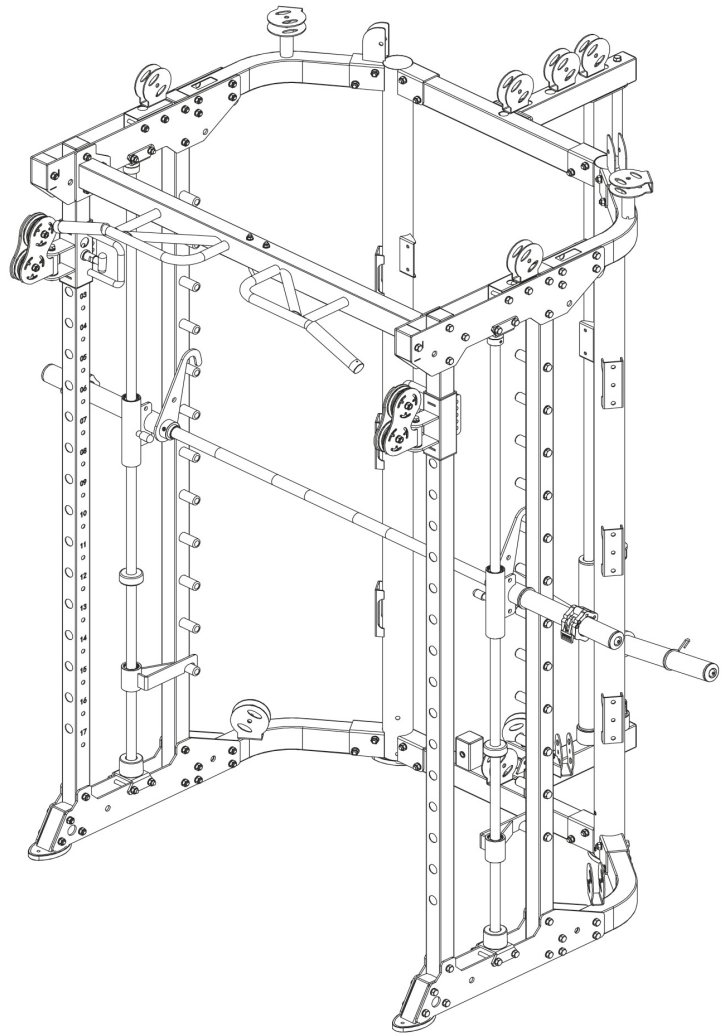

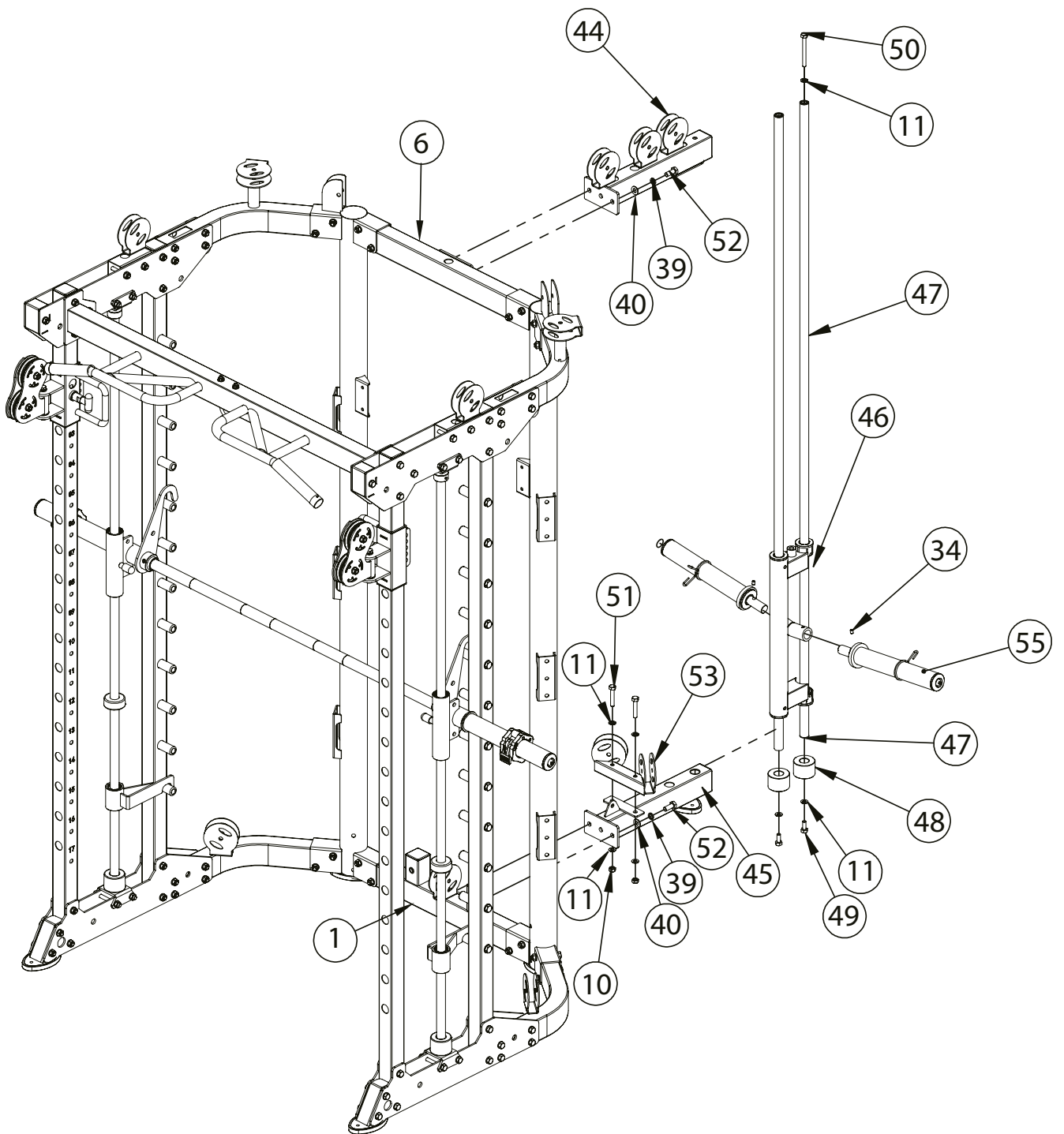

Step 5: Assembly of the Wires, Part 1

NOTICE

- + Use the 2745mm wires (56) and 95mm pulleys (57).
 - + The wires and pulleys must be assembled simultaneously.
 - + Start with one side of the machine and repeat the steps on the other side.
1. Connect the wire (56) to the weight (61) and place the weight inside the right upright frame (3).
 2. Route the wire (56) over one pulley (57, A) and attach the pulley (A) to the pulley bracket (A-1) with one bolt (60), one pulley plate (58), two washers (11) and one nut (10).
 3. Route the wire (56) around one pulley (57, B) and attach the pulley (B) to the pulley bracket (B-1) with one bolt (59), one pulley plate (58) and one washer (11).
 4. Route the wire (56) over over pulley (57, C) and attach the pulley (C) to the pulley bracket (C-1) with one bolt (60), one pulley plate (58), two washers (11) and one nut (10).
 5. Attach the loop end of the wire (56) to the outside of the sliding sleeve (29) with one bolt (49), two washers (11) and one nut (10).
 6. Repeat the steps 1 to 5 on the left side of the machine with the second wire (56).

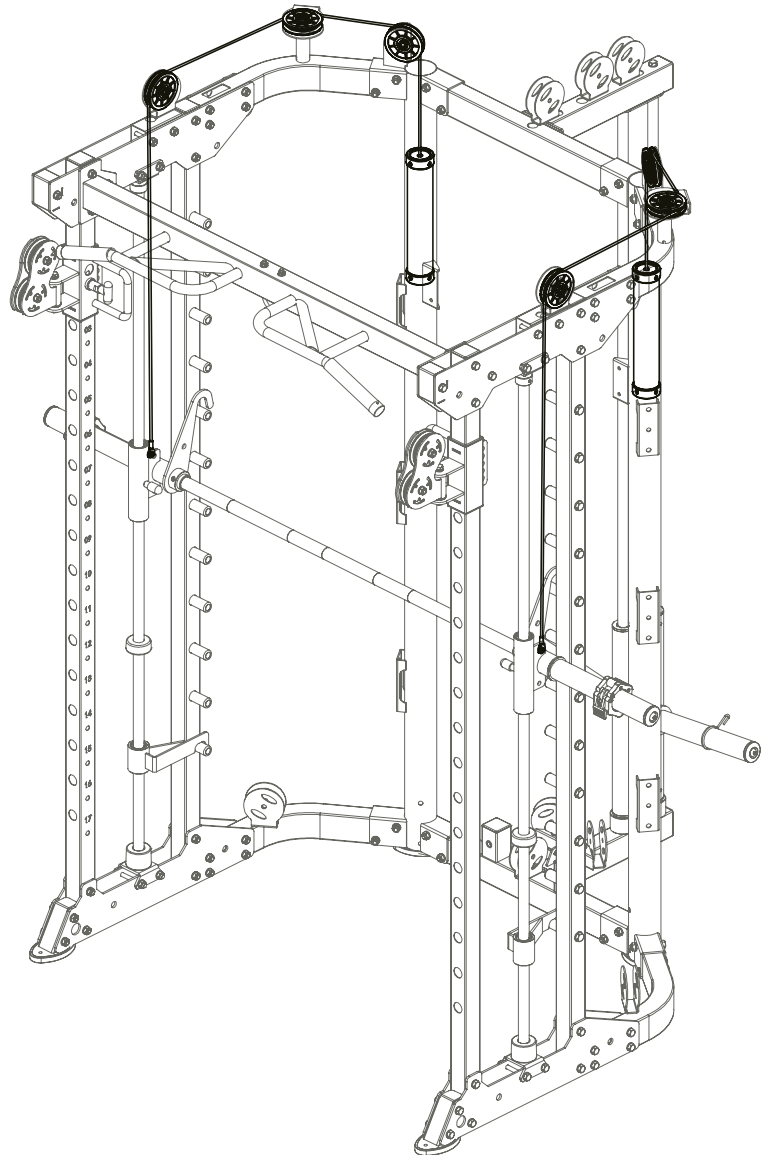

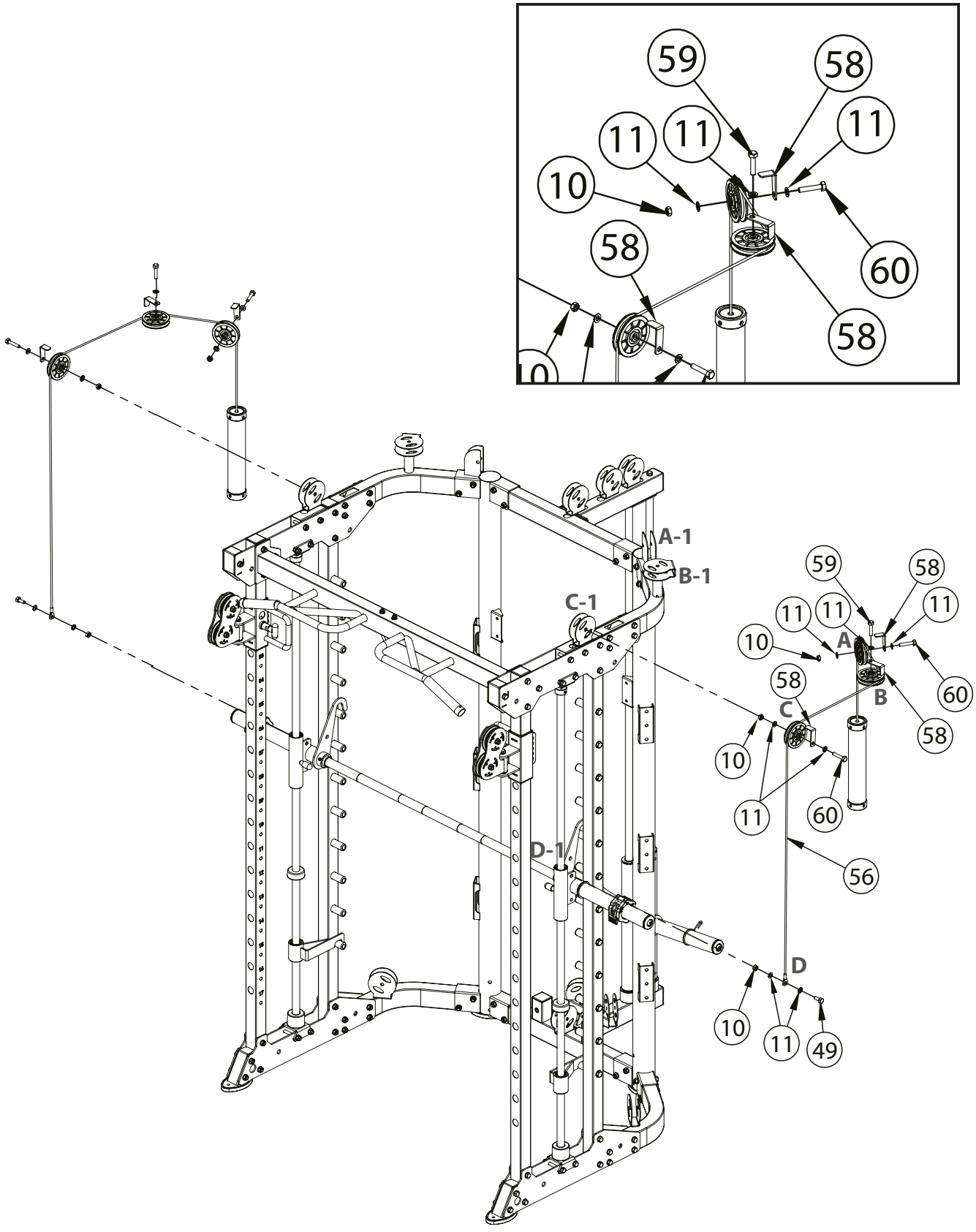

Step 6: Assembly of the Wires, Part 2

ⓘ NOTICE

- + Use the 4740mm wire (62) and 95mm pulleys (57).
- + The wire and pulleys must be assembled simultaneously.

1. Route the wire (62) under one pulley (57, A) and attach the pulley (A) to the pulley bracket (A-1) with one bolt (59), two washers (11) and one nut (10).
2. Route the wire (62) over one pulley (57, B) and attach the pulley (B) to the pulley bracket (B-1) with one bolt (59), two washers (11) and one nut (10).
3. Route the wire (62) under one pulley (57, C) and attach pulley (C) to the upper pulley bracket (C-1) in the hanging pulley frame (63) with one bolt (59), two washers (11) and one nut (10).
4. Route the wire (62) over one pulley (57, D) and attach the pulley (D) to the pulley bracket (D-1) with one bolt (59), two washers (11) and one nut (10).
5. Route the wire (62) over one pulley (57, E) and attach the pulley (E) to the pulley bracket (E-1) with one bolt (59), two washers (11) and one nut (10).
6. Attach the bolt end of the wire (62) to the big sliding sleeve (46; F-1).
7. Attach the footplate (65) to the connection tube (1) with two bolts (49) and two washers (11).
8. Attach the chain (66) to the ball end of the wire (62) with one of the snap hooks.
9. Attach the short bar (64) to the other snap hook of the chain (66).

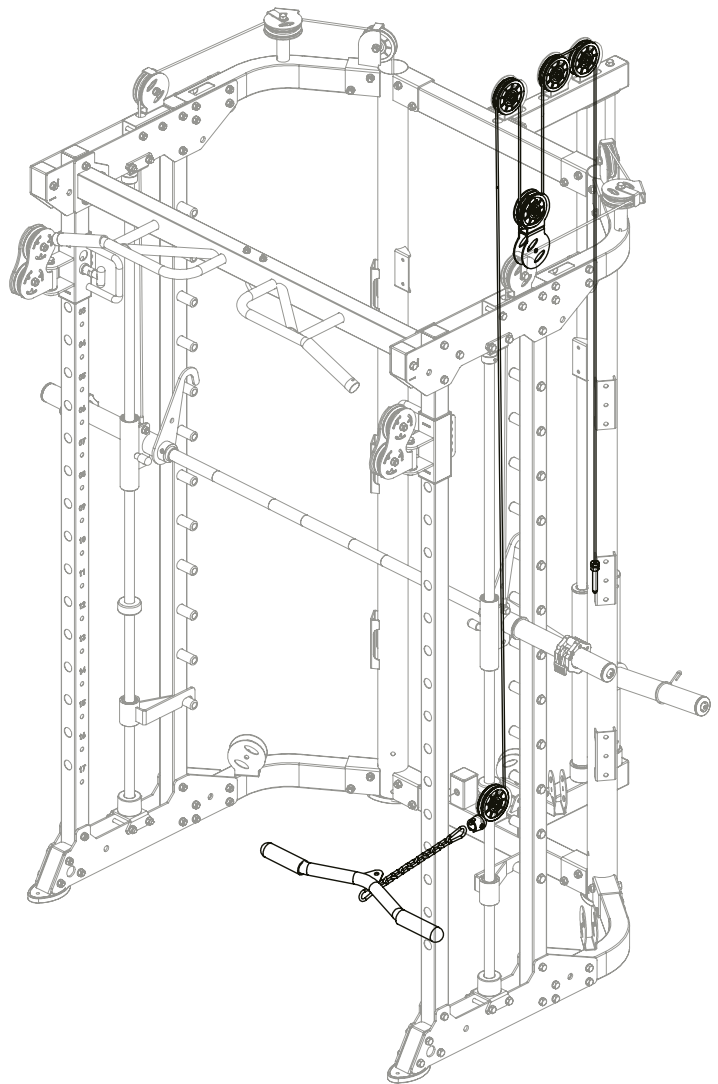

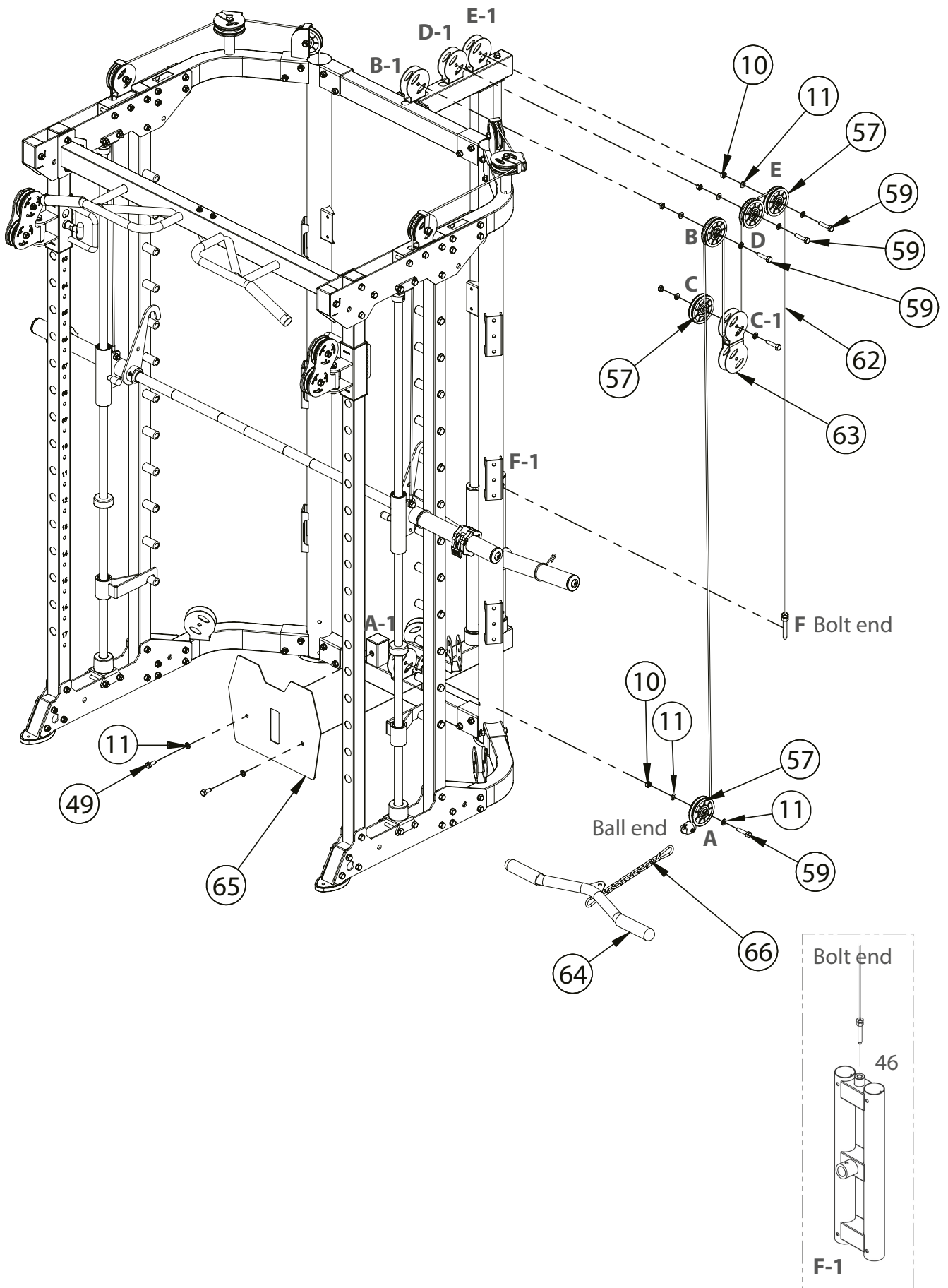

Step 7: Assembly of the Wires, Part 3

ⓘ NOTICE

- + Use the 4185mm wires (67) and 95mm pulleys (57).
 - + The wires and pulleys must be assembled simultaneously.
 - + Start with one side of the machine and repeat the steps on the other side.
1. Route the wire (67) over one pulley (57, A) and attach the pulley (A) between the upper plates (A-1) with one bolt (24), two pulley spacer sleeves (68), two washers (11) and one nut (10).
 2. Route the wire (67) over one pulley (57, B) and attach the pulley (B) between the upper plates (B-1) with one bolt (24), two pulley spacer sleeves (68), two washers (11) and one nut (10).
 3. Route the wire (67) under one pulley (57, C) and attach the pulley (C) to the upper pulley bracket (C-1) in the hanging pulley frame (63) with one bolt (59), two washers (11) and one nut (10).
 4. Attach the loop end of the wire (67) to the right upper bending tube (7; D-1) with one bolt (49), two washers (11) and one nut (10).
 5. Repeat the steps 1 to 4 on the left side of the machine with the second wire (67).

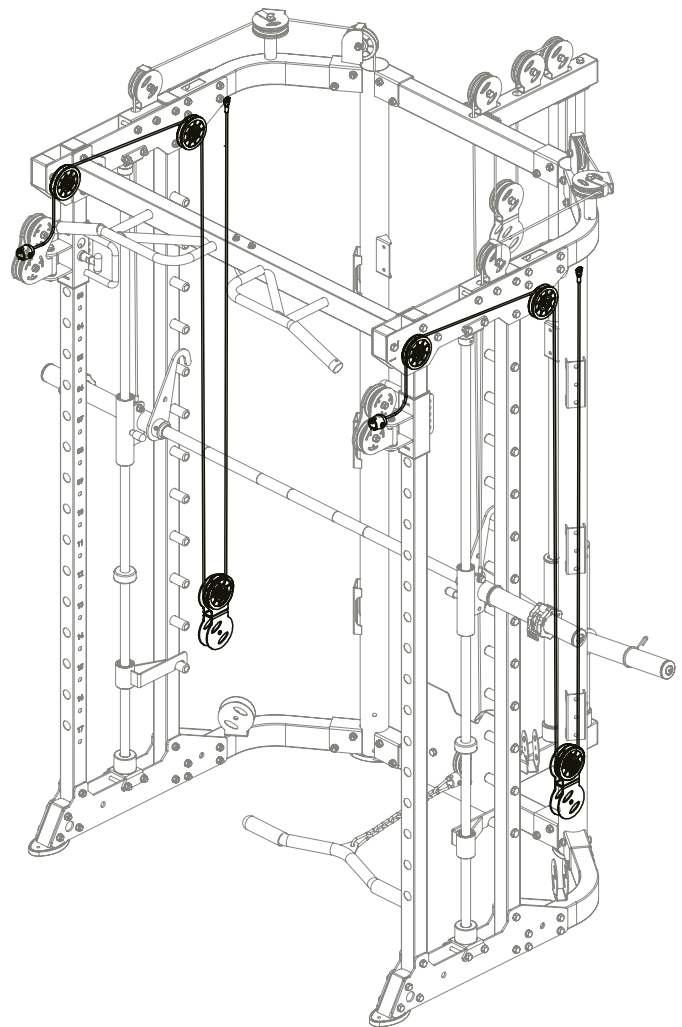

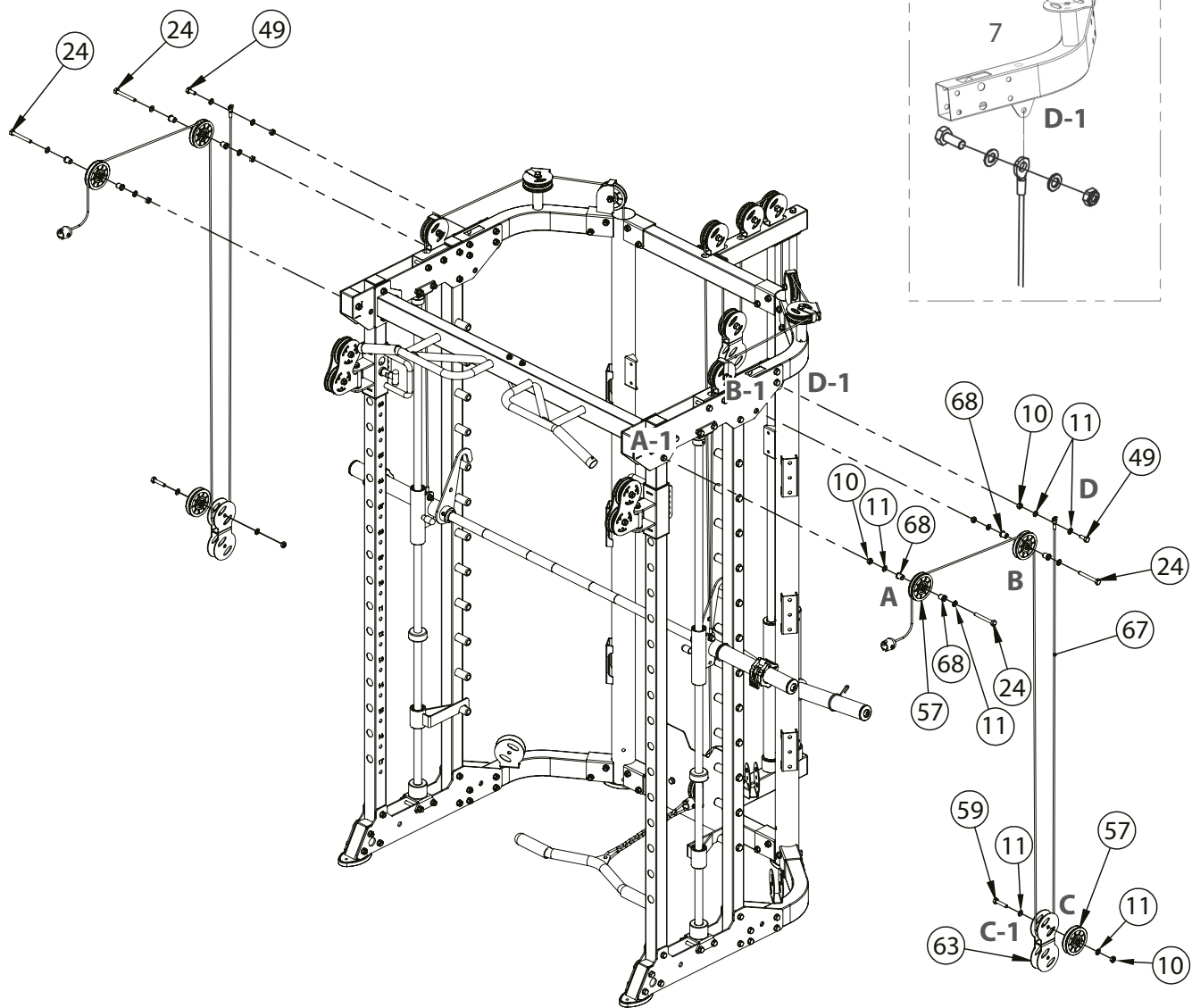

Step 8: Assembly of the Wires, Part 4

NOTICE

- + Use the 1705mm wire (70) and 95mm pulley (57).
 - + The wire and pulley must be assembled simultaneously.
1. Attach the bolt end of the wire (70) to the pulley frame (69).
 2. Route the wire (70) over one pulley (57) and attach the pulley (57) to the lower pulley bracket in the hanging pulley frame (63) with one bolt (59), two washers (11) and one nut (10).
 3. Attach the chain (71) to the end of the wire (70) and to the lower connection tube (45).

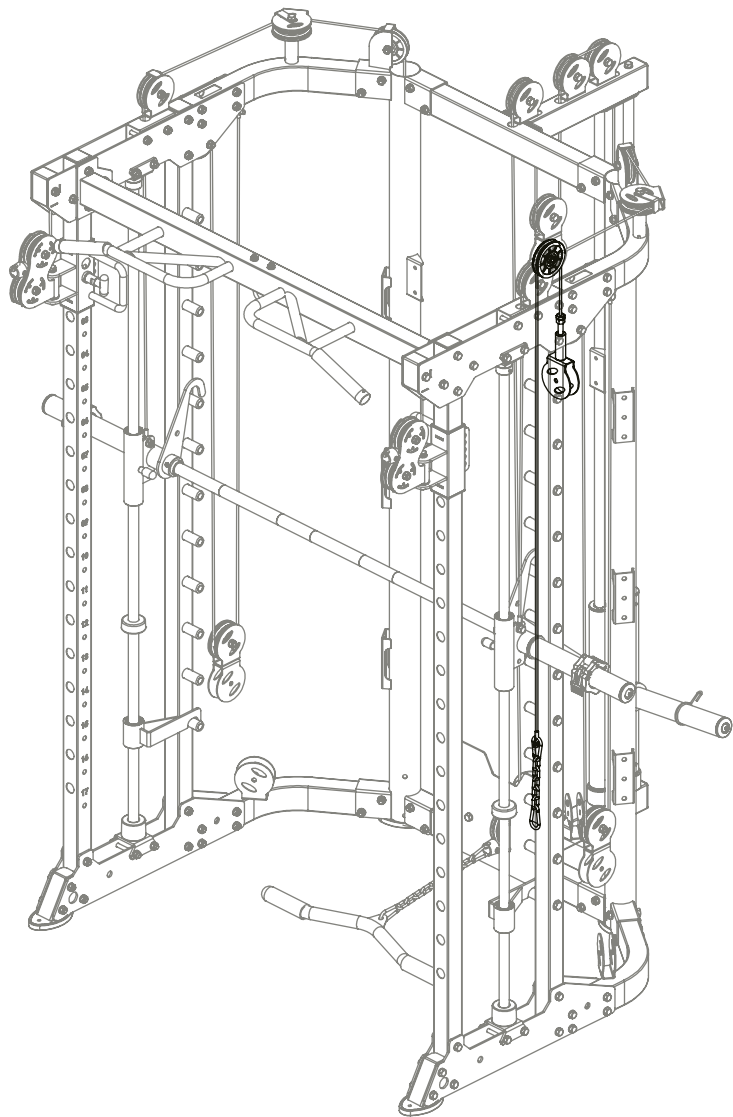

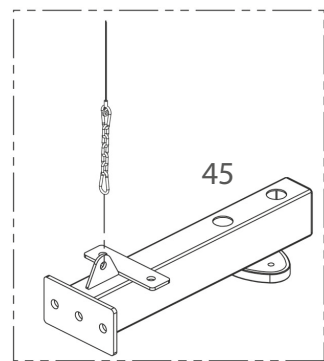
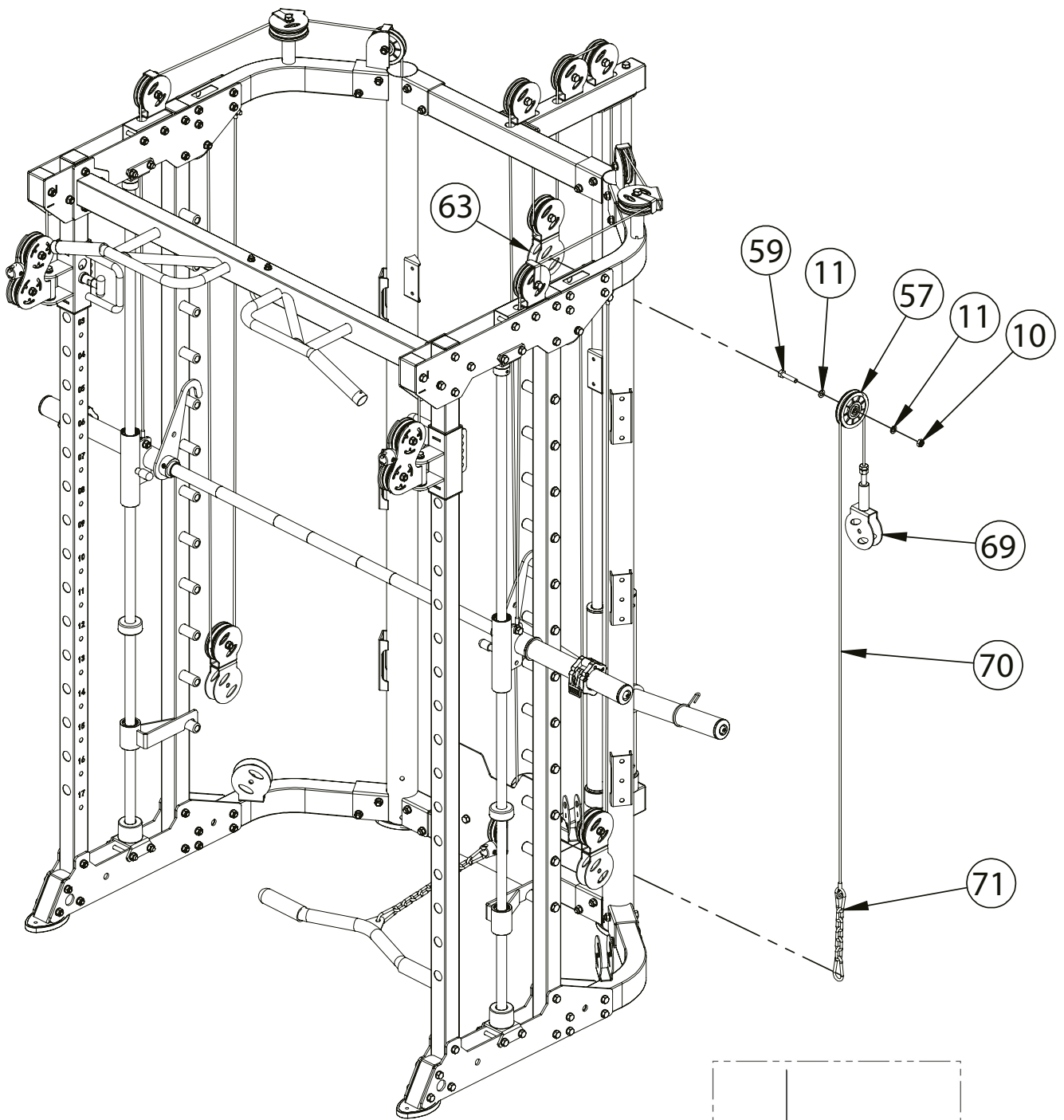

Step 9: Assembly of the Wires, Part 5

ⓘ NOTICE

- + Use the 9715mm wire (72), seven 95mm pulleys (57) and four 50mm pulleys (73).
- + The wire and pulleys must be assembled simultaneously.

1. Attach the end of the wire (72) to the right sliding tube (20) with one bolt (49), two washers (11) and one nut (10).
2. Route the wire (72) under one pulley (73, A) and attach the pulley (A) between the lower plates (A-1) with one bolt (24), two washers (11), two pulley spacer sleeves (68) and one nut (10).
3. Route the wire (72) under one pulley (73, B) and attach the pulley (B) between the lower plates (B-1) with one bolt (24), two washers (11), two pulley spacer sleeves (68) and one nut (10).
4. Route the wire (72) over one pulley (57, C) and attach the pulley (C) to the lower pulley bracket (C-1) in the hanging pulley frame (63) with one bolt (59), two washers (11) and one nut (10).
5. Route the wire (72) under one pulley (57, D) and attach the pulley (D) to the pulley bracket (D-1) on the right bending tube (5) with one bolt (59), two washers (11) and one nut (10).
6. Route the wire (72) under one pulley (57, E) and attach the pulley (E) to the right pulley bracket (E-1) in the double pulley bracket (53) with one bolt (59), two washers (11) and one nut (10).
7. Route the wire (72) over one pulley (57, F) and attach the pulley (F) to the pulley bracket (F-1) in the pulley frame (69) with one bolt (59), two washers (11) and one nut (10).
8. Route the wire (72) under one pulley (57, G) and attach the pulley (G) to the left pulley bracket (G-1) in the double pulley bracket (53) with one bolt (59), two washers (11) and one nut (10).
9. Route the wire (72) under one pulley (57, H) and attach the pulley (H) to the pulley bracket (H-1) on the left bending tube (4) with one bolt (59), two washers (11) and one nut (10).
10. Route the wire (72) over one pulley (57, I) and attach the pulley (I) to the lower pulley bracket (I-1) in the hanging pulley frame (63) with one bolt (59), two washers (11) and one nut (10).
11. Route the wire (72) under one pulley (73, J) and attach the pulley (J) between the lower plates (J-1) with one bolt (24), two washers (11), two pulley spacer sleeves (68) and one nut (10).
12. Route the wire (72) under one pulley (73, K) and attach the pulley (K) between the lower plates (K-1) with one bolt (24), two washers (11), two pulley spacer sleeves (68) and one nut (10).
13. Attach the end of the wire (72) to the left sliding tube (21) with one bolt (49), two washers (11) and one nut (10).

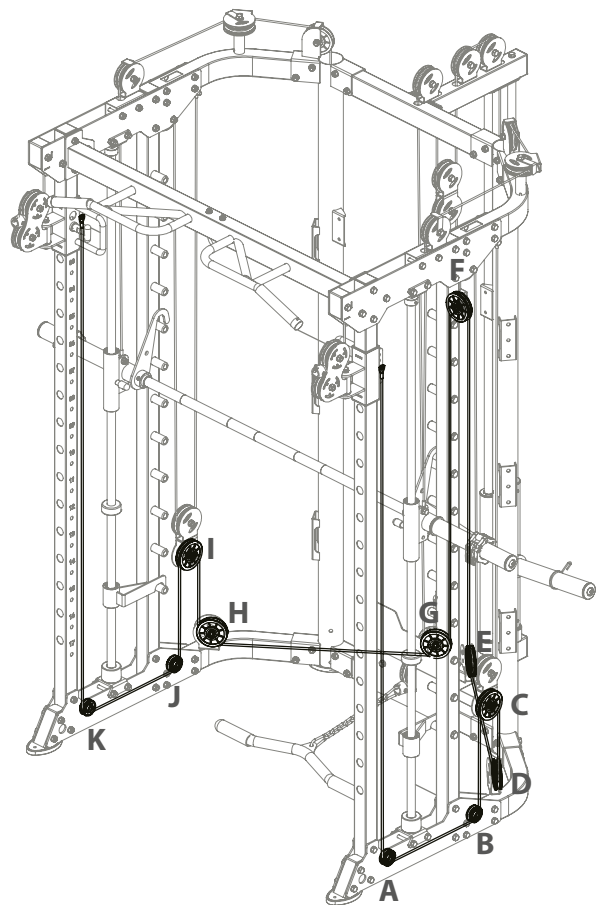

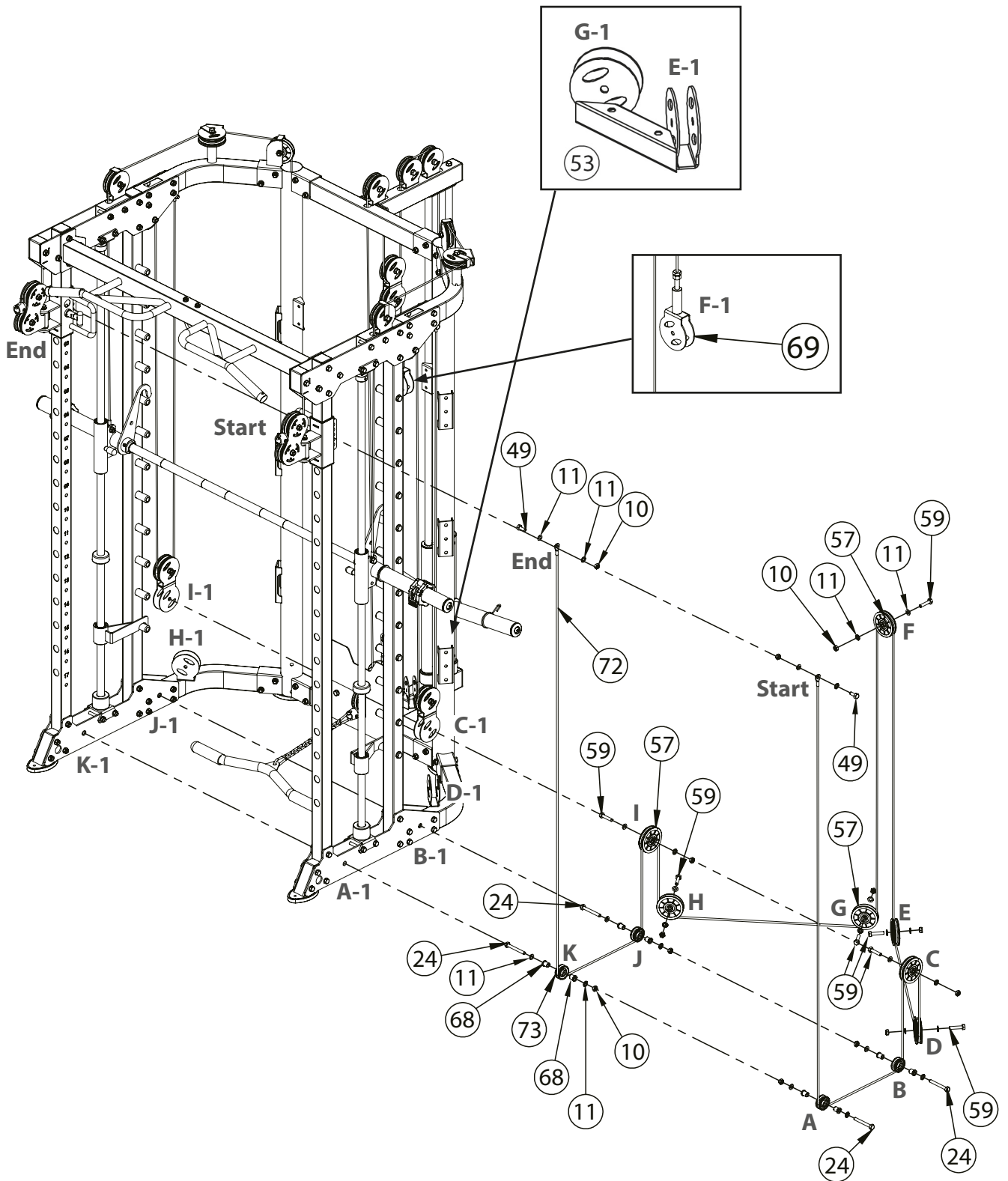

Step 10: Assembly of the Shield and Barbell Plate Holders

NOTICE

Install all bolts, washers and nuts before tightening.

1. Attach the shield (74) to the left and right upright frames (2 & 3) with four bolts (76), eight washers (77) and four nuts (78).
2. Attach a total of six barbell plate holders (75) to the left and right upright frames (2 & 3) with two bolts (76) and two washers (77) each.

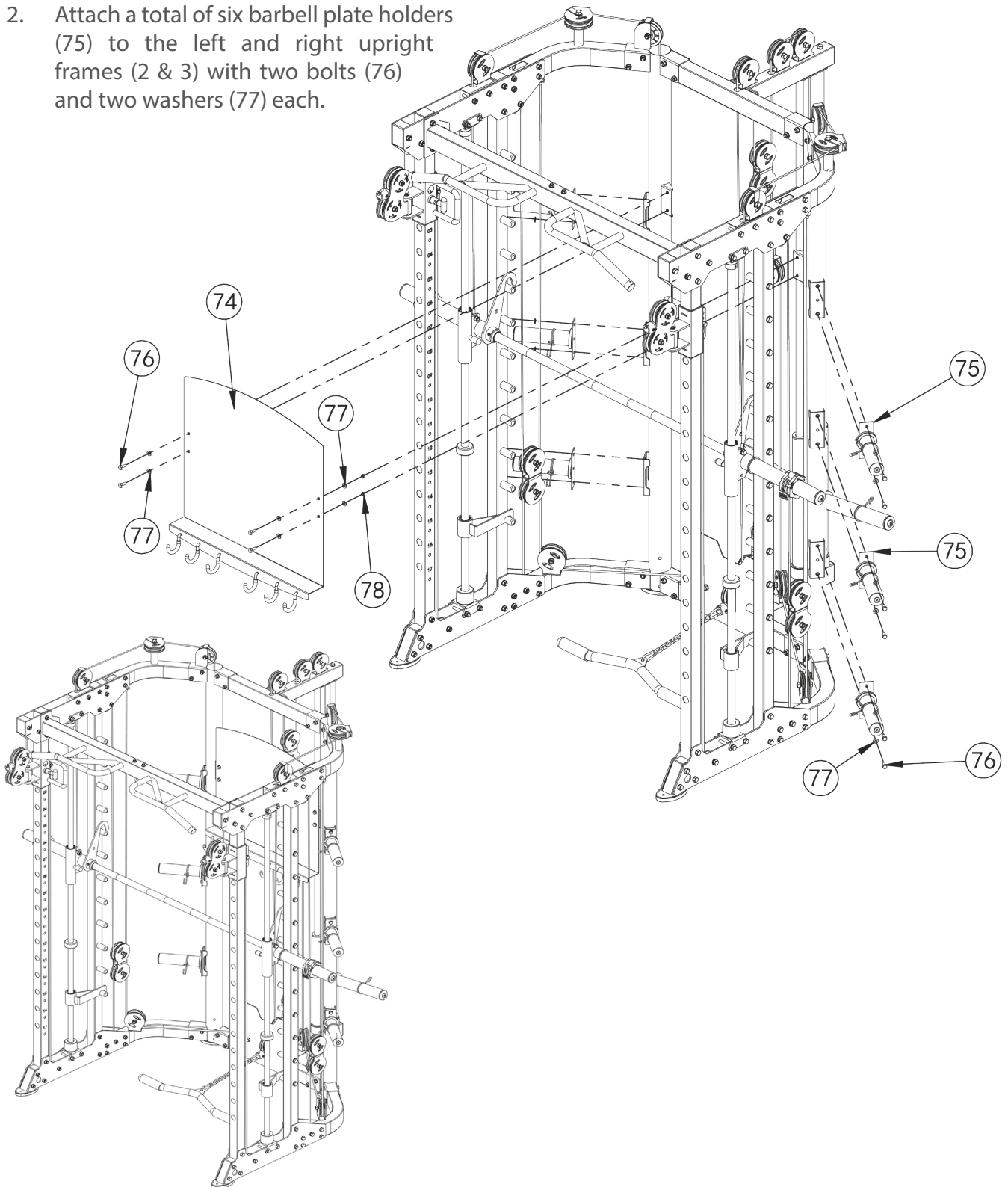

Step 11: Assembly of the Core Trainer and the Barbell Rod Cup

1. Attach the barbell rod cup (81) to the right upright frame (3) with two bolts (76) and two washers (77).
2. Attach the core trainer (79) to the lower plates (19) with one bolt (49), one washer (82) and two powder sleeves (80).

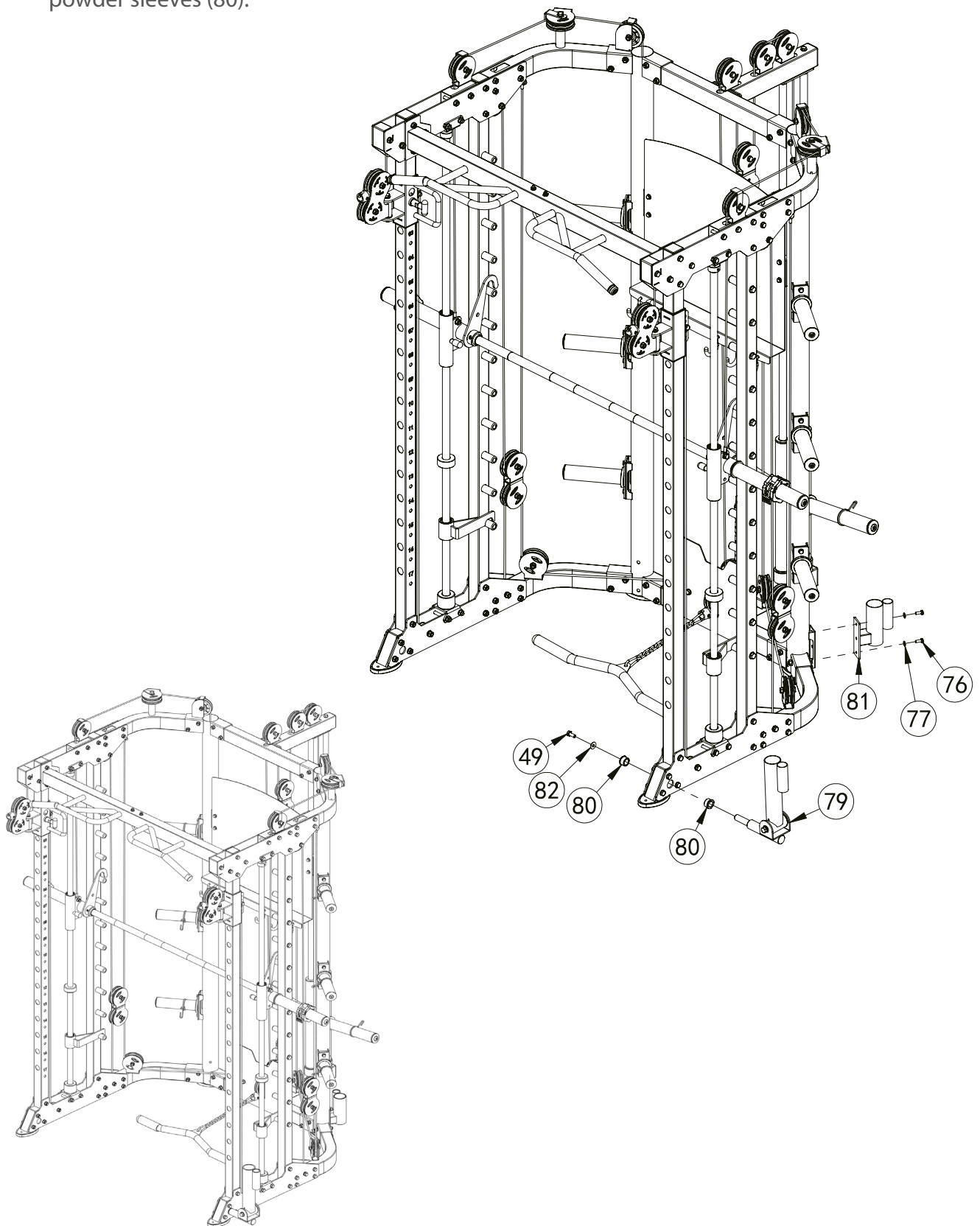

Step 12: Accessories

The CTX5 complete training system comes with a variety of attachments that can be used interchangeably like shown below. The following accessories are included in the scope of delivery:

- + 83: dip bar left
- + 84: dip bar right
- + 85: barbell rod holder right
- + 86: barbell rod holder left
- + 87: barbell rod holder short left
- + 88: barbell rod holder short right
- + 90: long bar
- + 91: ship rod
- + 92: hand belt
- + 93: pull lift device
- + 94: T-shaped pin
- + 95: leg curl tube

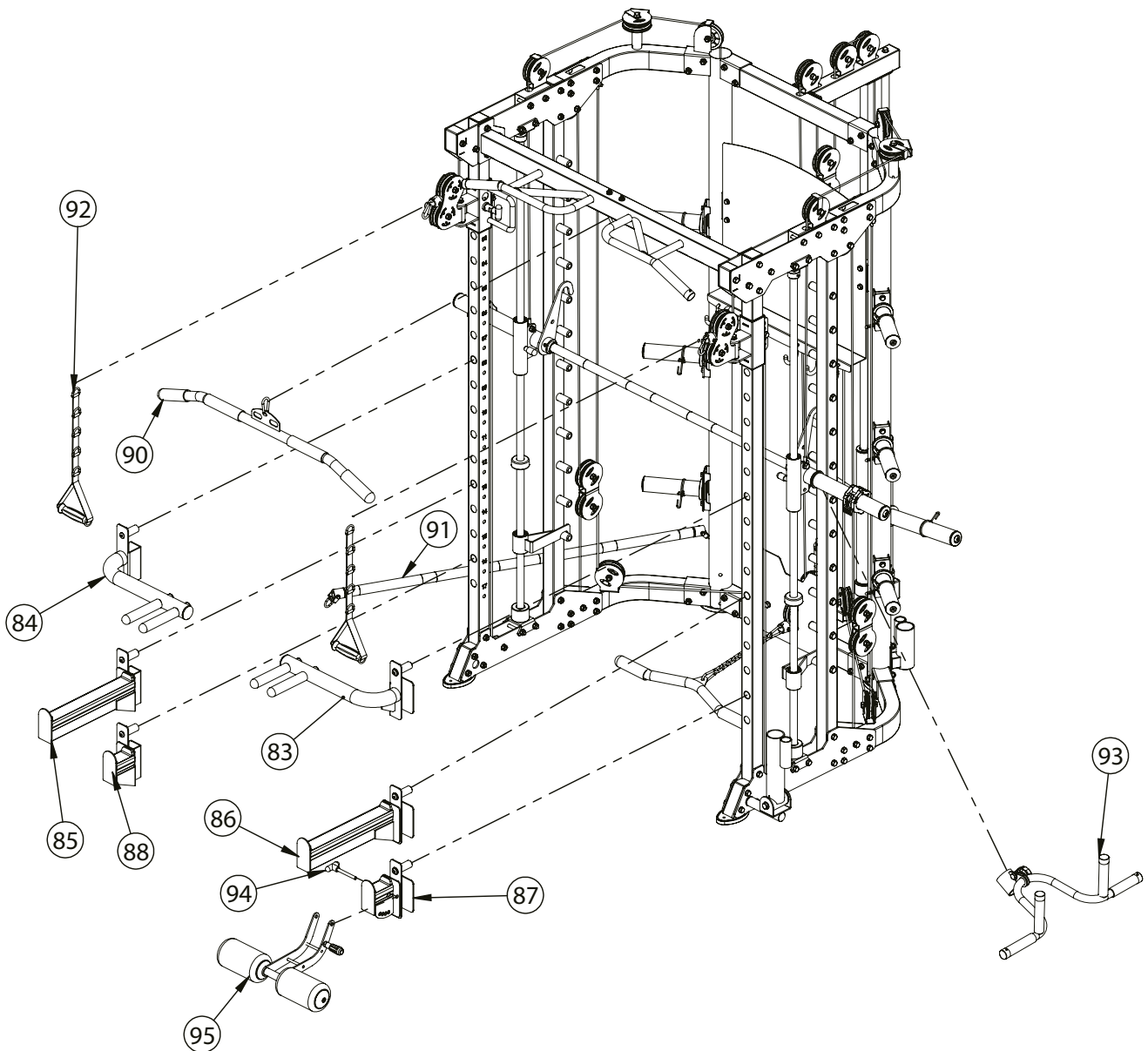

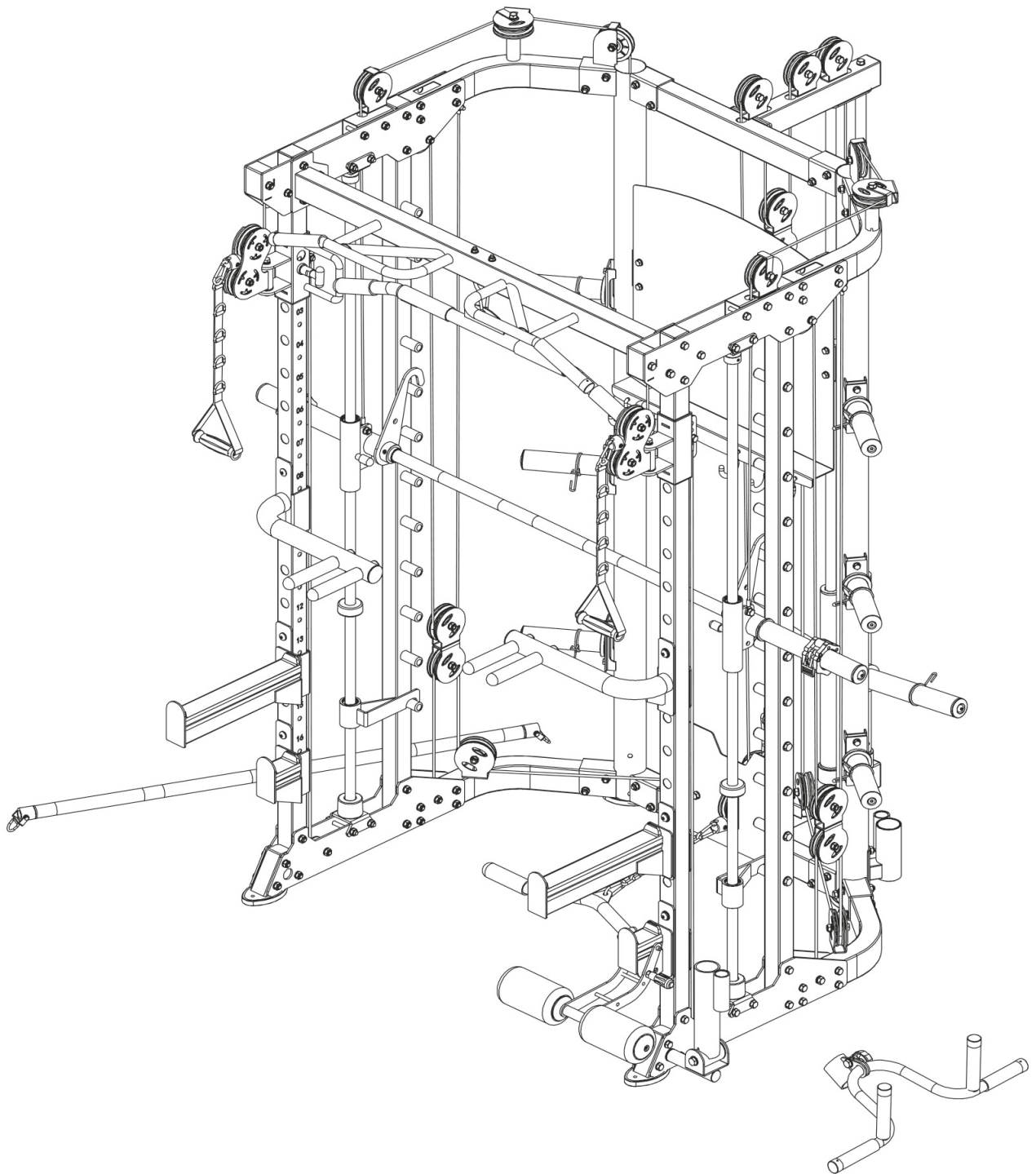

2.4 Optional Leg Press Plate

NOTICE

The leg press plate is an optional accessory for the CTX5 complete training system and is not included in the scope of delivery of the Smith machine itself. The leg press plate must be purchased separately.

Scan the QR code with the camera function or QR code scanner app of your mobile device to visit our shop and find more information on the leg press plate.



2.4.1 Scope of Delivery - Leg Press Plate

The scope of delivery consist of the following parts. At the beginning, check whether all parts and tools belonging to the device are included in the scope of delivery and whether damage has occurred. In the event of complaints, the contractual partner must be contacted directly.

CAUTION

If parts of the scope of delivery are missing or damaged, the assembly must not be carried out.

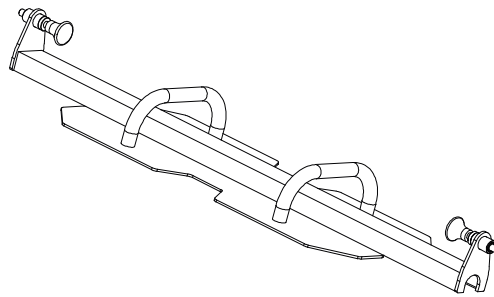

2.4.2 Assembly - Leg Press Plate

Attach the leg press plate (1) to the hooks of the barbell rod (41) and secure with the pins.

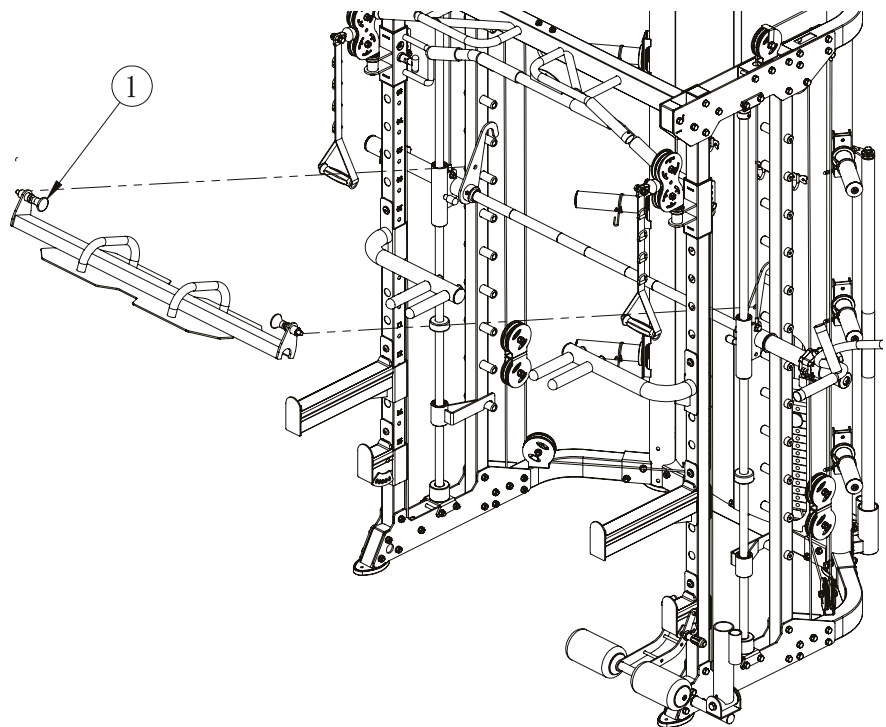

3.1 General Instructions



WARNING

- + The storage location should be chosen so that improper use by third parties or children can be prevented.
- + If your equipment does not have transportation wheels, the equipment must be disassembled before transportation.



ATTENTION

- + Make sure that the equipment is protected from moisture, dust and dirt in the selected storage location. The storage location should be dry and well ventilated and have a constant ambient temperature between 10°C and 35°C.

4.1 General Instructions



WARNING

- + Do not make any improper changes to the equipment.



CAUTION

- + Damaged or worn components may affect your safety and the life of the equipment. Therefore, immediately replace damaged or worn components. In such a case, contact the contract partner. The equipment must not be used until it has been repaired. If necessary, use only original spare parts.

ATTENTION

- + In addition to the instructions and recommendations for maintenance and care given here, additional service and/or repair work may be necessary; this must only be carried out by authorised service technicians.

4.2 Faults and Fault Diagnosis

The equipment undergoes regular quality controls during production. Nevertheless, faults or malfunctions may occur. Frequently, individual parts are responsible for these disturbances, an exchange is usually sufficient. Please refer to the following overview for the most common errors and how to correct them. If the equipment still does not function properly, contact your contract partner.

Fault	Cause	Solution
Grinding noises	Cables or pulleys do not run smoothly or are damaged	+ Visual inspection of the cable routing or the pulley guide + If damaged, replace the defective part
Cable without tension	Cable too loose	+ Check cable routing + Readjust cable tension
Squeaking & cracking noises	Screw connections loosened or too tight	+ Check or lubricate screw connections* + Check cable routing
Unit wobbles	+ Uneven ground + Loose screw connections	+ Align unit + Tighten screw connections
Heavy draught	+ Weight holders/guide rods too dry + Faulty cable routing	+ Lubricate guide rods* + Check cable routing

* With a grease-free silicone oil or silicone spray.

4.3 Maintenance and Inspection Calendar

To avoid damage from body sweat, the equipment must be cleaned with a damp towel (no solvents!) after each training session.

The following routine tasks must be performed at the specified intervals:

Part	Weekly	Monthly	Quarterly
Cables	C	I	
Screw connections		I	
Pulleys and cable routing		I	
Slide rails/Guide rods		I	
Cushions	C		
Legend: C = clean; I = inspect			

5 DISPOSAL

At the end of its operational life, this equipment cannot be disposed of in normal household waste. Instead, it must be disposed of via an recycling centre. Further information can be obtained from your local authority's recycling service.



The materials can be recycled as per their symbols. Through the reuse, recycling of materials or other forms of recovery of old equipment, you make an important contribution to the protection of the environment.

6 RECOMMENDED ACCESSORIES

To make your training experience even more efficient and pleasant, we recommend that you add suiting accessories to your fitness equipment. For training equipment like smith machines, weight benches or racks this could for example be a **floor mat**, which makes your fitness equipment stand more securely and also protects the floor from sweat but it could be also **additional weights, handles, foot straps** for leg exercises or **triceps ropes**. For some smith machines, there are also optional add-ons such as **leg presses** that make your workout even more intense and comprehensive.

Our range of accessories offers the highest quality and makes training even better. If you would like to find out more about compatible accessories, please go to the detail page of the product in our webshop (the easiest way is to enter the article number in the search field above) and go to the recommended accessories on this page. Alternatively, you can use the QR code provided. Of course, you can also contact our customer service: by telephone, e-mail, in one of our branches or via our social media channels. We will be happy to advise you!



floor mat



chest strap



tricep and curl bar



triceps rope

7.1 Serial Number and Model Name

In order to provide you with the best possible service, please have the model name, article number, serial number, exploded drawing and parts list ready. The corresponding contact options can be found in chapter 9 of this operating manual.

NOTICE

The serial number of your equipment is unique. It's located on a white sticker. The exact position of this sticker is shown in the following illustration.

Enter the serial number in the appropriate field.

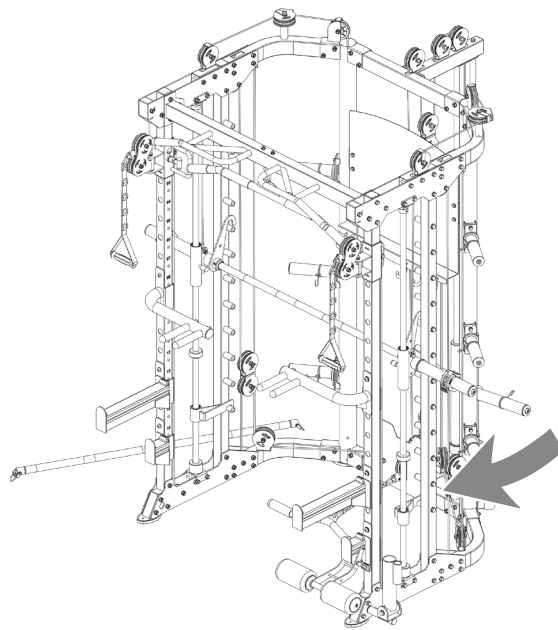

Serial number:

Brand / Category:

BodyMax / smith machine

Model Name:

CTX5 Complete Training System / CTX5/MS-PRO Leg Press Plate

SKU:

SEBR2720 / SEBR2725

7.2 Parts List

No.	Name	Specification	Qty.
1	connection tube		1
2	upright frame left		1
3	upright frame right		1
4	bending tube left		1
5	bending tube right		1
6	upper connection tube		1
7	upper bending tube right		1
8	upper bending tube left		1
9	hexagon bolt	M10*75	54
10	lock nut	M10	103
11	washer	Φ10	213
12	chin up bar		1
13	upper plate		4
14	pulley frame tube right		1
15	pulley frame tube left		1
16	upright tube		2
17	tube with hole right		1
18	tube with hole left		1
19	lower plate		4
20	sliding tube right		1
21	sliding tube leftf		1
22	foot tube cover		2
23	end tube		2
24	hexagon bolt	M10*80	14
25	lower base		2
26	upper base		2
27	guide rod	Φ25*1850	2
28	lock sleeve		2
29	sliding sleeve		2
30	rubber pad with groove	Φ60*Φ26*45	2
31	safety hook right		1

32	safety hook left		1
33	hexagon bolt	M10*90	8
34	socket set screw	M8*10	4
35	end cap	Φ51*Φ 42.5*36.6L	2
36	check ring	Φ60*Φ48.5*27L	2
37	pipe	Φ50*310*T0.5	2
38	button head socket screw	M12*40	2
39	spring washer	Φ12	6
40	washer	Φ12	6
41	barbell rod		1
42	inner pipe	Φ48*298*2.5T	2
43	rubber pad		2
44	upper connection tube short		1
45	lower connection tube		1
46	big sliding sleeve		1
47	guide rod hollow		2
48	rubber pad		2
49	hexagon bolt	M10*25	11
50	hexagon bolt	M10*95	1
51	hexagon bolt	M10*55	2
52	hexagon bolt	M12*30	4
53	double pulley bracket		1
55	back barbell plate holder		2
56	wire	Φ5*2745mm	2
57	pulley	Φ95	25
58	pulley plate	20*96*T3	6
59	hexagon bolt	M10*45	17
60	hexagon bolt	M10*50	4
61	weight		2
62	wire	Φ5*4740mm	1
63	hanging pulley frame		3
64	short bar		1
65	footplate		1
66	chain + 2 snap hook		1

67	wire	Φ5*4185mm	2
68	pulley spacer sleeve	Φ20*10.5*L20.5	16
69	pulley frame		1
70	wire	Φ5*1705mm	1
71	5 section chain + snap hook		1
72	wire	Φ5*9715mm	1
73	pulley	Φ50	4
74	shield		1
75	barbell plate holder		6
76	hexagon bolt	M8*20	18
77	washer	Φ8	22
78	lock nut	M8	4
79	core trainer		1
80	powder metallurgy sleeve	Φ33.2*Φ 29*Φ20*18	2
81	barbell rod cup		1
82	big washer	Φ25*10*2.0	1
83	dip bar left		1
84	dip bar right		1
85	barbell rod holder right		1
86	barbell rod holder left		1
87	barbell rod holder short left		1
88	barbell rod holder short right		1
89	barbell clamp collar		2
90	long bar		1
91	ship rod		1
92	hand belt		2
93	pull lift device		1
94	T shape pin	Φ10*100	1
95	leg curl tube		1

7.3 Exploded Drawing

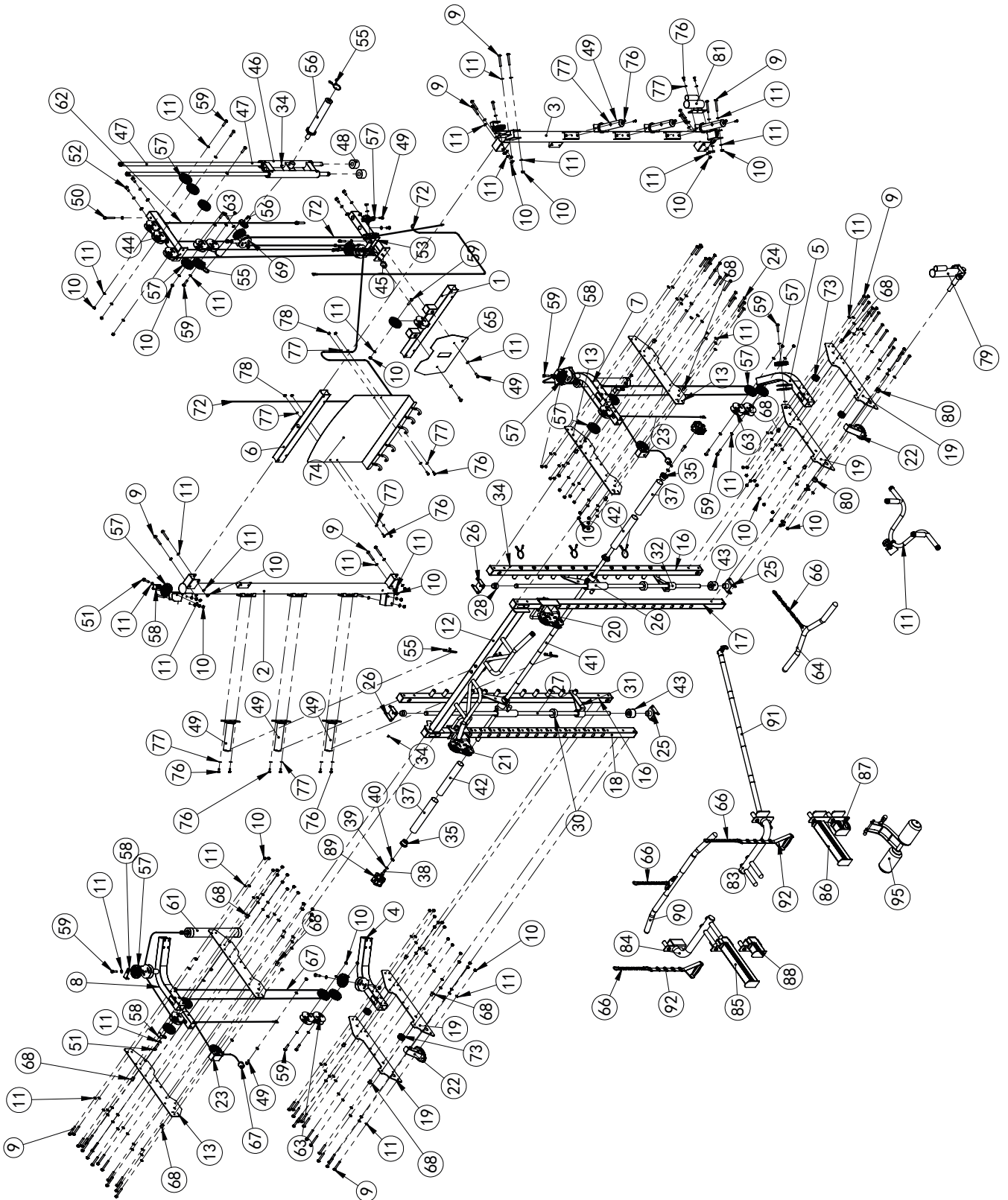

Training equipment from BodyMax® is subject to strict quality control. However, if a fitness equipment purchased from us does not work perfectly, we take it very seriously and ask you to contact our customer service as indicated. We are happy to help you by phone via our service hotline.

Error Descriptions

Your fitness equipment is developed for long-term, high-quality training. However, should a problem arise, please first read the operating instructions. For further assistance, please contact your contract partner or call our service hotline. To ensure your problem is solved as quickly as possible, please describe the defect as exactly as possible.

In addition to the statutory warranty, we provide a warranty for every fitness equipment purchased from us according to the following provisions.

Your statutory rights are not affected.

Warranty

The warranty is the first/original buyer.

Warranty periods

The following warranty periods begin on delivery of the fitness equipment.

Warranty period

The warranty periods, shown on our web shop, begin on delivery of the fitness equipment. The respective warranty periods for your equipment can be found on its product website.

Repair Costs

According to our choice, there will either be a repair, a replacement of individual damaged parts or a complete replacement. Spare parts, that have to be mounted while assembling the equipment, have to be replaced by the warranty personally and are not a part of repair. After the expiration of the warranty period for repair costs, a pure parts warranty applies, which does not include the repair, installation and delivery costs.

The terms of use are defined as follows:

- + Home use: solely for private use in private households up to 3 hours per day
- + Semi-professional use: up to 6 hours per day (e. g. rehabilitation centres, hotels, clubs, company gyms)
- + Professional use: more than 6 hours per day (e. g. commercial gyms)

Warranty Service

Within the warranty period, equipment which develops faults as a result of material or manufacturing defects, will be repaired or replaced at our discretion. Ownership of equipment or parts of equipment which have been replaced is transferred to us. The warranty period is not extended nor does a new warranty period begin following repair or replacement under the warranty.

Warranty Conditions

For the warranty to be valid, the following steps must be taken:

Please contact our customer service by email or phone. If the product under warranty has to be sent in for repair, the seller bears costs. After expiry of the warranty, the buyer bears the costs of transport and insurance. If the fault is covered by our warranty, you will receive a new or repaired equipment in return.

Warranty claims are invalid in case of damage resulting from:

- + misuse or improper handling
- + environmental influences (moisture, heat, electrical surge, dust, etc.)
- + failure to follow the current safety measures for the equipment
- + failure to follow the operating instructions
- + use of force (e. g. hitting, kicking, falling)
- + interventions which were not carried out by one of our authorized service centres
- + unauthorised repair attempts

Proof of Purchase and Serial Number

Please make sure that you are able to provide the appropriate receipt when claiming on your warranty. So that we can clearly identify the model of your equipment, and for the purposes of our quality control, you will need to give the serial number of your equipment, when contacting the service team. Where possible please have your serial number and your customer number ready when you call our service hotline. It will help us to deal with your request swiftly.







































If you cannot find the serial number on your fitness equipment, our service team is at your disposal to offer further information.

Service outside of the Warranty Period

We are also happy to issue an individual cost estimate if there is a problem with your fitness equipment after the warranty has expired, or in cases which do not fall under the terms of the warranty, e. g. normal wear and tear. Please contact our customer service team to find a quick and cost-effective solution to your problem. In such a case you will be responsible for the delivery costs.

Communication

Many problems can be solved just by speaking to us as your specialist supplier. We know how important it is to you as a user of the fitness equipment to have problems solved quickly and simply, so you can enjoy working out with minimal interruption. For that reason, we also want to resolve your queries quickly and in a straightforward manner. Thus, please always keep your customer number and the serial number of the faulty equipment handy.

DE	DK	FR
<p>TECHNIK</p> <p> +49 4621 4210-900</p> <p> +49 4621 4210-698</p> <p> technik@sport-tiedje.de</p> <p> Öffnungszeiten entnehmen Sie unserer Homepage.</p> <p>SERVICE</p> <p> 0800 20 20277 (kostenlos)</p> <p> 04621 4210 - 0</p> <p> info@sport-tiedje.de</p> <p> Öffnungszeiten entnehmen Sie unserer Homepage.</p>	<p>TEKNIK OG SERVICE</p> <p> 80 90 16 50</p> <p>+49 4621 4210-945</p> <p> info@fitshop.dk</p> <p> Åbningstider kan findes på hjemmesiden.</p> <p>PL</p> <p>DZIAŁ TECHNICZNY I SERWIS</p> <p> 22 307 43 21</p> <p>+49 4621 42 10-948</p> <p> info@fitshop.pl</p> <p> Godziny otwarcia można znaleźć na stronie głównej.</p>	<p>TECHNIQUE & SERVICE</p> <p> +33 (0) 189 530984</p> <p>+49 4621 42 10 933</p> <p> info@fitshop.fr</p> <p> Vous trouverez les heures d'ouverture sur notre site Internet.</p> <p>BE</p> <p>TECHNIQUE & SERVICE</p> <p> 02 732 46 77</p> <p>+49 4621 4210 933</p> <p> info@fitshop.be</p> <p> Vous trouverez les heures d'ouverture sur notre site Internet.</p>
UK	NL	INT
<p>CUSTOMER CARE POWERHOUSE</p> <p> +44 141 737 2249 or +44 141 876 3972</p> <p> customercare@powerhouse-fitness.co.uk</p> <p> You can find the opening hours on our homepage.</p>	<p>TECHNISCHE DIENST & SERVICE</p> <p> +31 172 619961</p> <p> info@fitshop.nl</p> <p> De openingstijden vindt u op onze homepage.</p>	<p>TECHNICAL SUPPORT & SERVICE</p> <p> +49 4621 4210-944</p> <p> service-int@sport-tiedje.de</p> <p> You can find the opening hours on our homepage.</p>
ES	AT	CH
<p>TECNOLOGÍA Y SERVICIOS</p> <p> 911 238 029</p> <p> info@fitshop.es</p> <p> Consulta nuestro horario de apertura en la página web.</p>	<p>TECHNIK & SERVICE</p> <p> 0800 20 20277 (Freecall)</p> <p>+49 4621 42 10-0</p> <p> info@sport-tiedje.at</p> <p> Öffnungszeiten entnehmen Sie unserer Homepage.</p>	<p>TECHNIK & SERVICE</p> <p> 0800 202 027</p> <p>+49 4621 42 10-0</p> <p> info@sport-tiedje.ch</p> <p> Öffnungszeiten entnehmen Sie unserer Homepage.</p>

Please find a detailed overview including address and opening hours for all stores of Powerhouse Fitness in the UK on the following website:

www.powerhouse-fitness.co.uk/storelocator

WE LIVE FITNESS

WEBSHOP AND SOCIAL MEDIA

The Sport-Tiedje Group is Europe's largest specialist for home fitness equipment with currently 70 stores and one of the world's most renowned online mail order companies for fitness equipment.

Powerhouse Fitness is part of the Sport-Tiedje Group. Private customers order via the 25 web shops in the respective national language or have their desired equipment assembled on site. In addition, the company supplies fitness studios, hotels, sports clubs, companies and physio practices with professional equipment for endurance and strength training.

The Sport-Tiedje group offers a wide range of fitness equipment from renowned manufacturers, high-quality in-house developments and comprehensive services, such as a build-up service and sports scientific advice before and after the purchase. The company employs numerous sports scientists, fitness trainers and competitive athletes.

Visit us also on our social media platforms or our blog!



<http://www.powerhouse-fitness.co.uk/>
www.powerhouse-fitness.co.uk/blog/



<https://www.facebook.com/powerhousefitness.co.uk>



www.instagram.com/powerhousefitness_uk/



www.youtube.com/user/PHFTV/

TAURUS

 cardiostrong

BODYCRAFT

 **BodyMax**
POWERHOUSE FITNESS GROUP

Notes

