

BODYCRAFT

Assembly and Operating Instructions

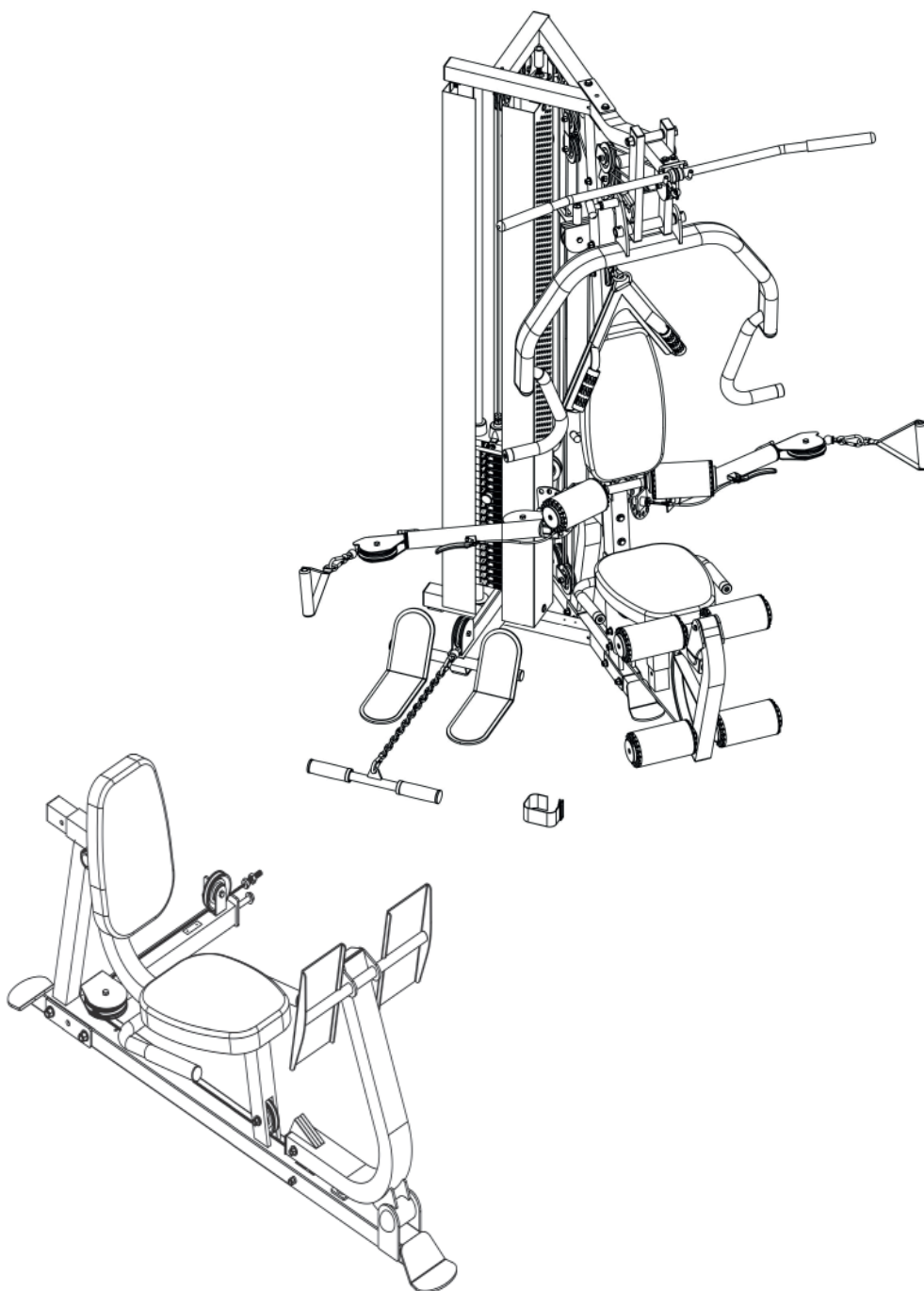

~ 210 Min.



214 kg

L 143 | W 143 | H 210



~ 90 Min.



36 kg

L 164 | W 82 | H 83

FSUKSEMG6221.01.01

SKU: SEMG6221/ SEMG6222

Multi Gym GX

Content

1	GENERAL INFORMATION	8
1.1	Technical Data	8
1.2	Personal Safety	9
1.3	Set-Up Place	10
2	ASSEMBLY	12
2.1	General Instructions	12
2.2	Scope of Delivery: Multi-gym	13
2.3	Assembly: Multi-gym	16
2.4	Scope of Delivery: Leg Press	35
2.5	Assembly: Leg Press	37
3	STORAGE AND TRANSPORT	42
3.1	General Instructions	42
4	TROUBLESHOOTING, CARE AND MAINTENANCE	43
4.1	General Instructions	43
4.2	Faults and Fault Diagnosis	43
4.3	Maintenance and Inspection Calendar	44
5	DISPOSAL	44
6	RECOMMENDED ACCESSORIES	45
7	ORDERING SPARE PARTS	46
7.1	Serial Number and Model Name	46
7.2	Parts List: Multi-gym	47
7.3	Exploded Drawing: Multi-gym	51
7.4	Parts List: Leg Press	52
7.5	Exploded Drawing: Leg Press	53
8	WARRANTY	54
9	CONTACT	56

Dear customer,

Thank you for choosing BodyCraft training equipment. BodyCraft equipment inspires with its multifunctionality and excellent workmanship and is one of the highest quality fitness equipment for home use in terms of innovation and technology. BodyCraft weight stations, for example, offer a very wide range of exercise possibilities. This ranges from traditional strength training such as bench presses to rehabilitation exercises and workouts for complex sports such as golf, tennis or badminton.

Further information can be found at www.fitshop.co.uk

Intended Use

The equipment may only be used for its intended purpose.

The equipment is only suitable for home use. The equipment is not suitable for semi-professional (e.g. hospitals, associations, hotels, schools, etc.) and commercial or professional use (e.g. fitness studios).

Disclaimer

BODYCRAFT

BodyCraft® is a registered brand of the company Fitness Authority Industrial Co., LTD. All rights reserved. Any use of this trademark without the explicit written permission of Fitness Authority Industrial Co., LTD is prohibited.

Product and manual are subject to change. Technical data can be changed without advance notice.

ABOUT THIS MANUAL

Please carefully read the entire manual before installation and first use. The manual will help you to quickly set up the system and explains how to safely use it. Make sure that all persons exercising with the equipment (especially children and persons with physical, sensory, mental or motor disabilities) are informed about this manual and its contents in advance. In case of doubt, responsible persons must supervise the use of the equipment.

Due to ongoing changes and software optimisations, the manual may have to be updated. If you notice any discrepancies during assembly or use, please refer to the manual uploaded to the webshop. The latest manual is always available there.



This equipment has been manufactured according to the latest safety knowledge. As far as possible, potential safety hazards which could cause injury have been eliminated. Make sure to carefully follow the instructions and that all parts are securely in place. If required, read through the instructions again to correct any mistakes.

Training devices must be classified according to accuracy and use. Accuracy classes are only applicable to devices that display training data.

Accuracy classes

Class A: high accuracy.

Class B: medium accuracy.

Class C: low accuracy.

The use classes explain the intended use of the training device.

Use classes

Class S (studio): professional and/or commercial use.

These training devices are intended for the use in training rooms of facilities such as sports clubs, school facilities, hotels, clubs and studios whose access and supervision is specifically regulated by the owner (person with legal responsibility).

Class H (home use): use at home.

These stationary training devices are intended for the use in private homes where access to the training device is regulated by the owner (person with legal responsibility).

Please pay close attention to the safety and maintenance instructions given here. The contract partner cannot be held liable for damage to health, accidents or damage to the equipment when it is not used in accordance with these instructions.

The following safety instructions may appear in this manual:

► **ATTENTION**

This notice indicates potentially hazardous situations which, if not avoided, may result in property damage.

⚠ **CAUTION**

This notice indicates potentially hazardous situations which, if not avoided, may result in slight or minor injuries!

⚠ **WARNING**

This notice indicates potentially hazardous situations which, if not avoided, may result in death or serious injuries!

⚠ **DANGER**

This notice indicates potentially hazardous situations which, if not avoided, will result in death or serious injuries!

ⓘ **NOTICE**

This notice indicates further useful information.

Retain these instructions in a safe place for future reference, maintenance or when ordering replacement parts.

1.1 Technical Data

Multi-gym

Weight and Dimensions

Packaging dimensions (L x W x H) and article weight (gross, incl. packaging) approx.:

Box 1:	200 cm x 43 cm x 17 cm	47.11 kg
Box 2:	111 cm x 101 cm x 25 cm	85.9 kg
Box 3:	188 cm x 18 cm x 12 cm	11.3 kg

Weight plates (5 x 4.5 kg):	27 cm x 14 cm x 13 cm	22.42 kg
2x weight plates (7 x 4.5 kg):	28 cm x 19 cm x 15 cm	31.265 kg

Article weight incl. weight stack (net, without packaging) approx.:	214 kg
Set-up dimensions (L x W x H) approx.:	143 cm x 143 cm x 210 cm

Cables and Pulleys

Weight stack:	1 (90 kg)
Weight plates:	19 + 1 (4.5 kg each)
Cable material:	Steel
Cover material:	Nylon
Pulley size:	90 mm/ 114 mm

Maximum user weight:	130 kg
----------------------	--------

Optional Leg Press

Packaging dimensions (L x W x H) approx.:	169.2 cm x 63.3 x 16.6 cm
Set-up dimensions (L x W x H) approx.:	164 cm x 82 cm x 83 cm

Article weight (gross, incl. packaging) approx.:	41.4 kg
Article weight (net, excl. packaging) approx.:	36 kg

Maximum user weight:	150 kg
----------------------	--------

Use class:	H
------------	---

1.2 Personal Safety

DANGER

- + Before you start using the equipment, you should consult your physician that this type of exercise is suitable for you from a health perspective. Particularly affected are persons who: have a hereditary disposition to high blood pressure or heart disease, are over the age of 45, smoke, have high cholesterol values, are overweight and/or have not exercised regularly in the past year. If you are under medical treatment that affects your heart rate, medical advice is absolutely essential.
- + Note that excessive training can seriously endanger your health. Please also note that heart rate monitoring systems can be inaccurate. If you notice any signs of weakness, nausea, dizziness, pain, shortness of breath, or other abnormal symptoms, stop exercising immediately and seek advice from your doctor if necessary.
- + The owner must communicate all warnings and instructions to the user.

WARNING

- + This equipment may not be used by children under the age of 14.
- + Children should not be allowed unsupervised access to the equipment.
- + Persons with disabilities must have a medical license and must be under strict observation when using the equipment.
- + The equipment is strictly for use by one person at a time.
- + Keep your hands, feet and other body parts, hair, clothing, jewellery and other objects well clear of moving parts.
- + During use, wear suitable sports clothing rather than loose or baggy clothing. When wearing sports shoes, make sure they have suitable soles, preferably made of rubber or other non-slip materials. Shoes with heels, leather soles, studs or spikes are unsuitable. Never exercise barefoot.
- + Always start each workout with a light warm-up and end with a cool-down phase.
- + Using the machine as a support during stretching exercises or attaching resistance bands, ropes or other accessories to it, may cause injuries.

CAUTION

- + If your equipment needs to be connected to the power supply with a mains cable, make sure that the cable is not a potential tripping hazard.
- + Make sure that nobody is within the range of motion of the equipment during training so as not to endanger you or other persons.
- + Be aware that if adjustment devices are left protruding, they may impede the user's movement.
- + The weights should remain in the user's field of vision during the entire exercise to prevent danger to third parties.

ATTENTION

- + Do not insert any objects of any kind into the openings of the device.

1.3 Set-Up Place

WARNING

- + Do not place the equipment in main corridors or escape routes.

CAUTION

- + Choose a location in which to place the equipment such that there is enough free space/clearance to the front, the rear and to the sides of the equipment.
- + The training room should be well ventilated during training and not be exposed to any draughts.
- + Choose the place in which to set up the equipment such that there is enough free space/clearance to the front, the rear and to the sides of the equipment.
- + The free area in the direction from which the exercise equipment is accessed must be at least 0.6 m larger than the exercise area.
- + The set-up and mounting surface of the equipment should be flat, loadable and solid.
- + If your device is to be mounted on the wall/ceiling, make sure that you use the appropriate assembly material to avoid possible damages or personal injuries. The contractual partner accepts no liability for this.

ATTENTION

- + The device may only be used in one building, in sufficiently tempered and dry rooms (ambient temperatures between 10°C and 35°C). The equipment should not be used outdoors or in rooms with high humidity (over 70%) like swimming pools.
- + A floor protective mat/equipment underlay can help to protect high-quality floor coverings (parquet, laminate, cork, carpets) from dents and sweat and can help to level out slight unevenness.
- + For Class S equipment, the exercise equipment may only be used in areas where access, supervision and control are specifically regulated by the owner.

W A L L

W A L L

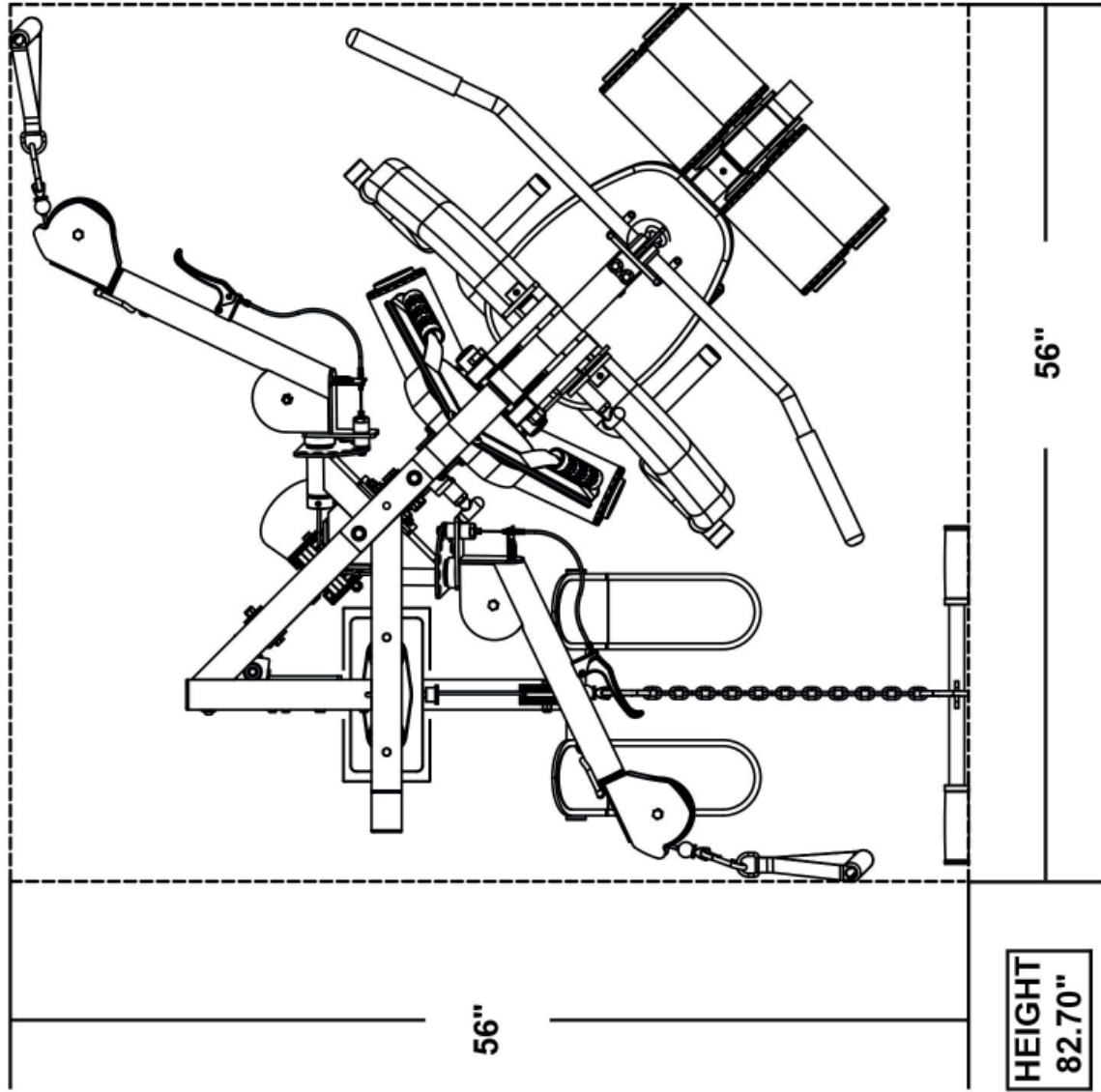

2.1 General Instructions



DANGER

- + Do not leave any tools, packaging materials such as foils or small parts lying around, as otherwise there is a danger of suffocation for children. Keep children away from the equipment during assembly.



WARNING

- + Pay attention to the instructions attached to the equipment in order to reduce the risk of injuries.



CAUTION

- + Ensure to have sufficient room for movement in each direction during assembly.
- + The assembly of the equipment must be carried out by at least two adults. If in doubt, seek the help of a third technically skilled person.



ATTENTION

- + To prevent damage to the equipment and the floor, assemble the equipment on a mat or packaging board.



NOTICE

- + In order to make the assembly as simple as possible, some screws and nuts to be used can already be pre-assembled.
- + Ideally, assemble the equipment at its later set-up place.

2.2 Scope of Delivery: Multi-gym

The scope of delivery consist of the following parts. At the beginning, check whether all parts and tools belonging to the device are included in the scope of delivery and whether damage has occurred. In the event of complaints, the contractual partner must be contacted directly.

CAUTION

If parts of the scope of delivery are missing or damaged, the assembly must not be carried out.

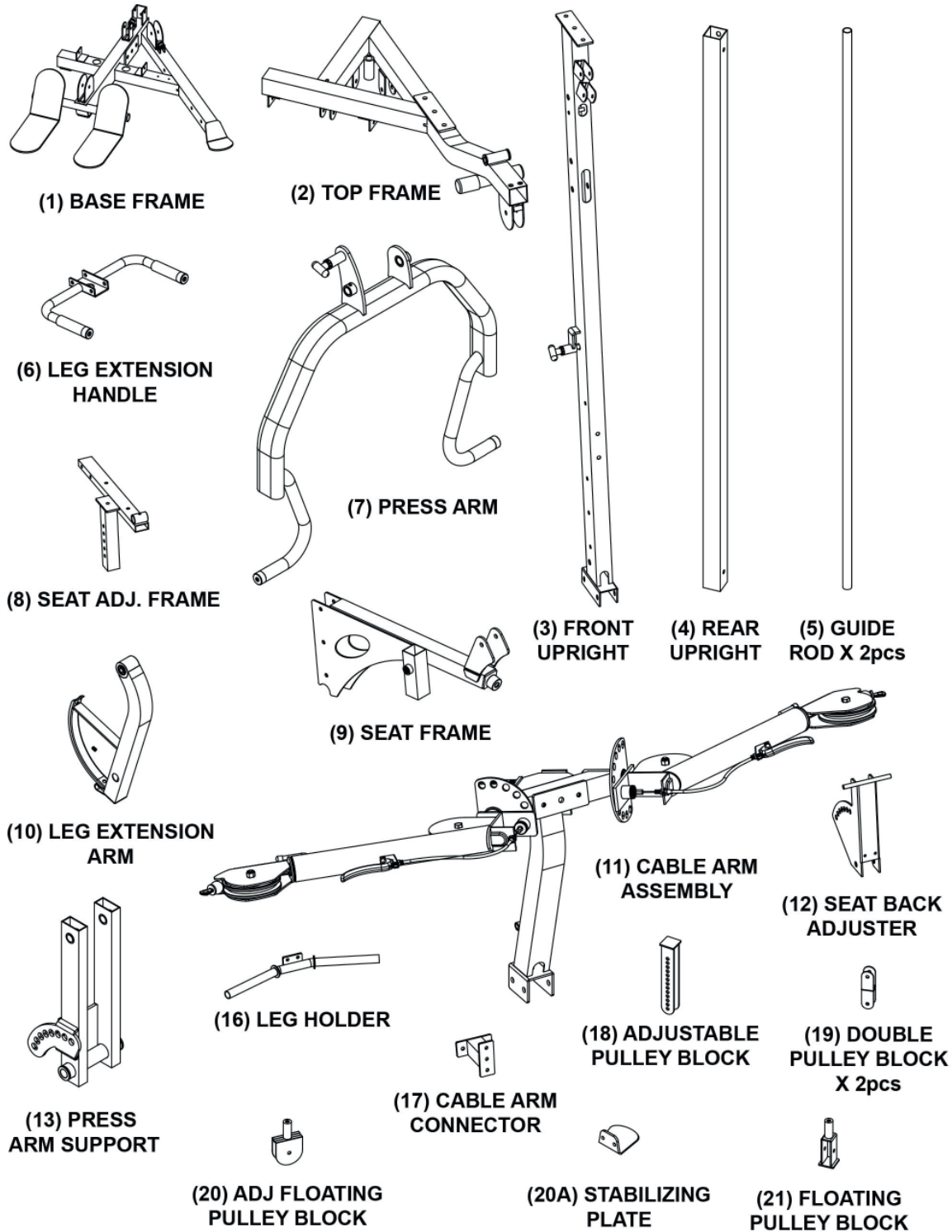



(22) LAT BAR HOLDER



(23) 150LBS LONGER STACK SPACER X 2pcs



(23A) 200LBS SHORTER STACK SPACER X 2pcs



(24) METAL HINGE X 2pcs



(25) CABLE GUIDE PLATE

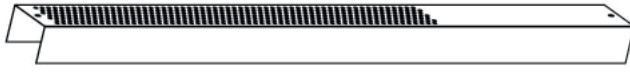

(26) WEIGHT SHROUD X 2pcs



(27) 1" FOAM ROLLER HOLDER X 2pcs



(28) PRESS ARM AXLE

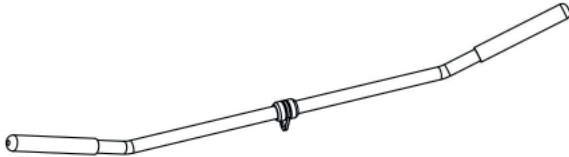

(29) LAT BAR



(30) CURL BAR



(32) PULLEY GUIDE BRACKET X 4pcs



(38) SELECTOR ROD



(39) TOP PLATE

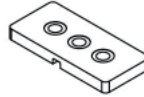

(40) WEIGHT PLATE X 19pcs



(40A) 185L NONSLIP X 2pcs



(41) 235L NONSLIP X 2pcs



(42) AB CRUNCH STRAP



(43) SINGLE HANDLE X 2pcs



(44) ANKLE STRAP



(45) LINK



(46) CLIP X 5pcs

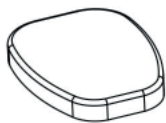

(47) SEAT PAD

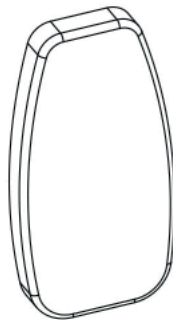

(48) BACK PAD



(49) FOAM PAD & (50) FOAM PAD COVER X 6pcs



(64) 114mm PULLEY X 2pcs



(65) 90mm PULLEY X 29pcs



(66) 50 X 75mm RECT.END CAP



(67) 50mm SQ. END CAP X 5pcs



(68) 25 X 50mm RECT. END CAP X 6pcs



(69) 40 X 80mm OVAL PLUG X 2pcs



(70) 1-1/4" ROUND END PLUG X 2pcs



(71) PLASTIC WASHER X 6pcs



(72) ALUMINUM CAP X 6pcs



(73) 1" ID PLASTIC GUIDE ROD HOLDER X 2pcs



(77) 3/8" ID BUSHING X 8pcs



(79) RUBBER CUSHION X 2pcs



(83) RUBBER STOPPER



(84) LOCKING SPRING KNOB



(86) SHORTER POP PIN



(94) SELECTOR PIN



(87) TOP CABLE



(111) 1/2" HALF THREADED STUD



(88) AB CRUNCH CABLE



(89) LOWER CABLE



(90) CONNECT CABLE



(129) GUIDE ROD MOUNT



(91) CABLE ARM CABLE

NO. DESCRIPTION QTY.

95	5/8" X 5-1/2" HEX BOLT	1
96	3/8" X 4-3/4" HEX BOLT	1
97	3/8" X 4" HEX BOLT	2
98	3/8" X 3-1/8" HEX BOLT	2
98A	3/8" X 3-1/4" HEX BOLT	2
99	3/8" X 3" HEX BOLT	13
100	3/8" X 2-3/4" HEX BOLT	1
101	3/8" X 1-3/4" HEX BOLT	19
102	3/8" X 1-3/4" HEX THREADED BOLT	2
103	3/8" X 1" HEX THREADED BOLT	4
104	5/16" X 1/2" ROUND BOLT	4
105	TOP PLATE BOLT	1
109	3/8" X 3/4" INNER HEX SCREW	6
115	5/8" WASHER	2
116	3/8" WASHER	52
117	5/16" WASHER	4
123	5/8" NYLON NUT	1
124	3/8" NYLON NUT	40
127	4mm HEX WRENCH	1
128	5mm HEX WRENCH	1

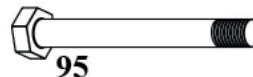

95



101



115



96



102



116

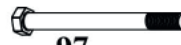

97



103



117

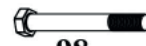

98



104

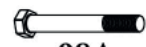

98A



105

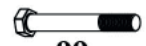

99



109

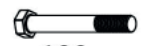

100



123



124



127



128

2.3 Assembly: Multi-gym

Before assembly, take a close look at the individual assembly steps shown and carry out the assembly in the order given.

NOTICE

- + First loosely screw all parts together and check that they fit properly. Tighten the screws using the tool only when you are instructed to do so.
- + If you have difficulty recognising the graphics, we recommend that you open and/or download the PDF instructions stored in the webshop on your end device (e.g. smartphone, tablet or PC). There you have the option of zooming in closer. Please note that the Adobe Acrobat Reader programme must be installed on your end device in order to open the file.

Step 1: Assembly of Front and Rear Upright, Guide Rods and Weight Plates

1. Assemble the front upright (3) to the base frame (1) by using two bolts (99), four washers (116) and two nuts (116).
2. Assemble the shorter pop pin (86) to the front upright (3).
3. Assemble the rear upright (4) to the base frame (1) by using three screws (109) and three washers (116).
4. Insert two guide rod holders (73) into the holes on the base frame (1).
5. Insert two guide rods (5) into the guide rod holders (73).

ATTENTION

- + If you have purchased the optional 200Lbs pound weight stack, please use the 200Lbs shorter stack spacers (23A) instead of the 150Lbs longer stack spacers (23).
6. Slide two 200Lbs stack spacers (23A) onto the guide rods, followed by two rubber cushions (79).
 7. Slide the weight plates (40) onto the guide rods (5), making sure the selector holes point towards front and rear side.
 8. Attach the top plate (39) to the selector rod (38) by using the top plate bolt (105). Tighten the top plate bolt (105) by using a hex key.
 9. Slide the top plate (39) onto the guide rods and guide the selector rod (94) through the center holes of the weight plates (40).
 10. Insert two end plugs (70) into the ends of the round foot plate tube.

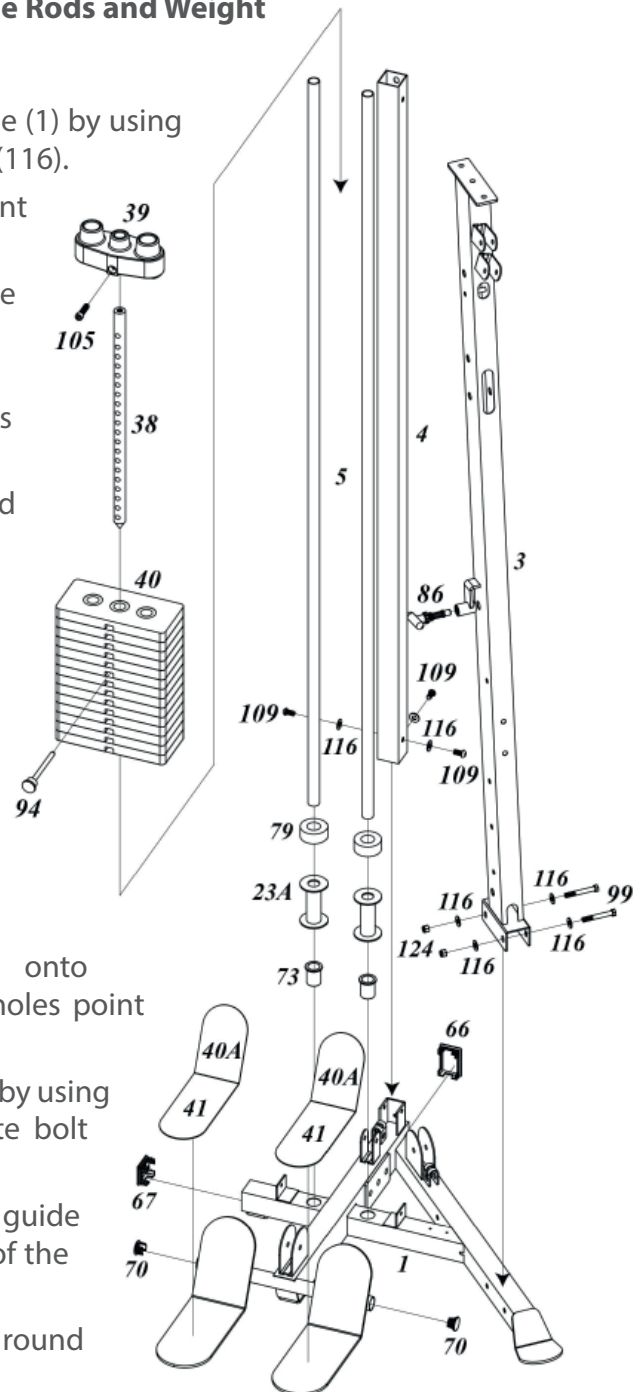

11. Insert one end cap (66) into the rear of the base frame (1).
12. Insert one end cap (67) into the side of the base frame (1).

Step 2: Assembly of the Top Frame

1. Insert the guide rod mount (129) onto the guide rods (5).
2. Assemble the guide rod mount (129) to the top frame (2) by using two bolts (108).
3. Screw two set screws (112) into the guide rods (5).
4. Place the top frame (2) on top, making sure to insert the guide rods (5) and rear upright (4).
5. Assemble the top frame (2) to the rear upright (4), by using three screws (109) and three washers (116).
6. Assemble the top frame (2) to the front upright (3) by using two bolts (98), four washers (116) and two nylon nuts (124).
7. Assemble the lat bar holder (22) to the top frame (2) by using two bolts (104) and two washers (117).
8. Insert three end caps (67) to each end of the top frame (2).

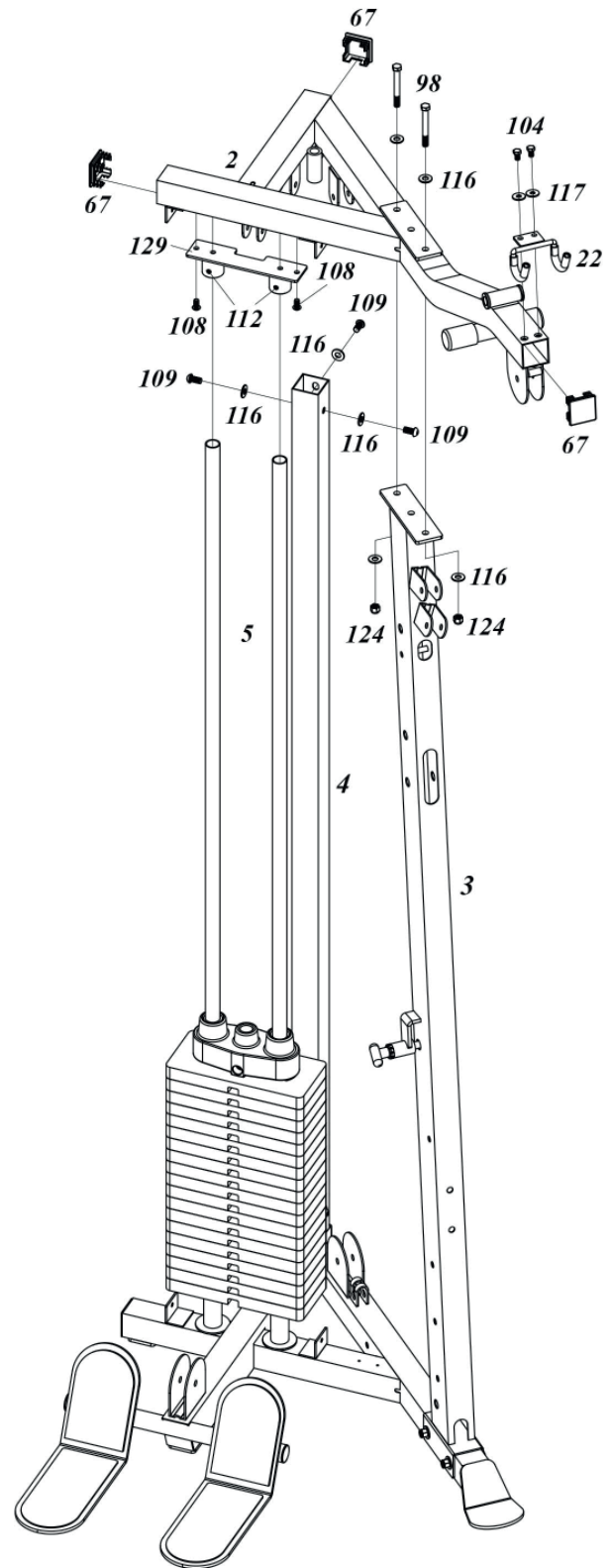

Step 3: Assembly of the Cable Arm Assembly

1. Assemble the cable arm assembly (11) to cable arm connector (17) by using two bolts (103) and two washers (116).
2. Assemble the cable arm connector (17) to front upright (3) by using two bolts (97), four washers (116) and two nylon nuts (124).
3. Assemble the cable arm assembly (11) and stabilizing plate (20A) to base frame (1) by using two bolts (98A), four washers (116) and two nylon nuts (124).

NOTICE

You may need to loosen the bolts at the top of the cable arm assembly bottom frame so that the holes line up.

4. Slide the axle of each cable arm (14) through the holes on the selector plate in the cable arm assembly (11) and fasten them by using two spacers (34) and two axle collars (35).
5. Tighten two set screws (112) on the axle collars (35) with an allen wrench.

ATTENTION

Make sure that each cable arm (14) pivots freely and that cables are not twisted.

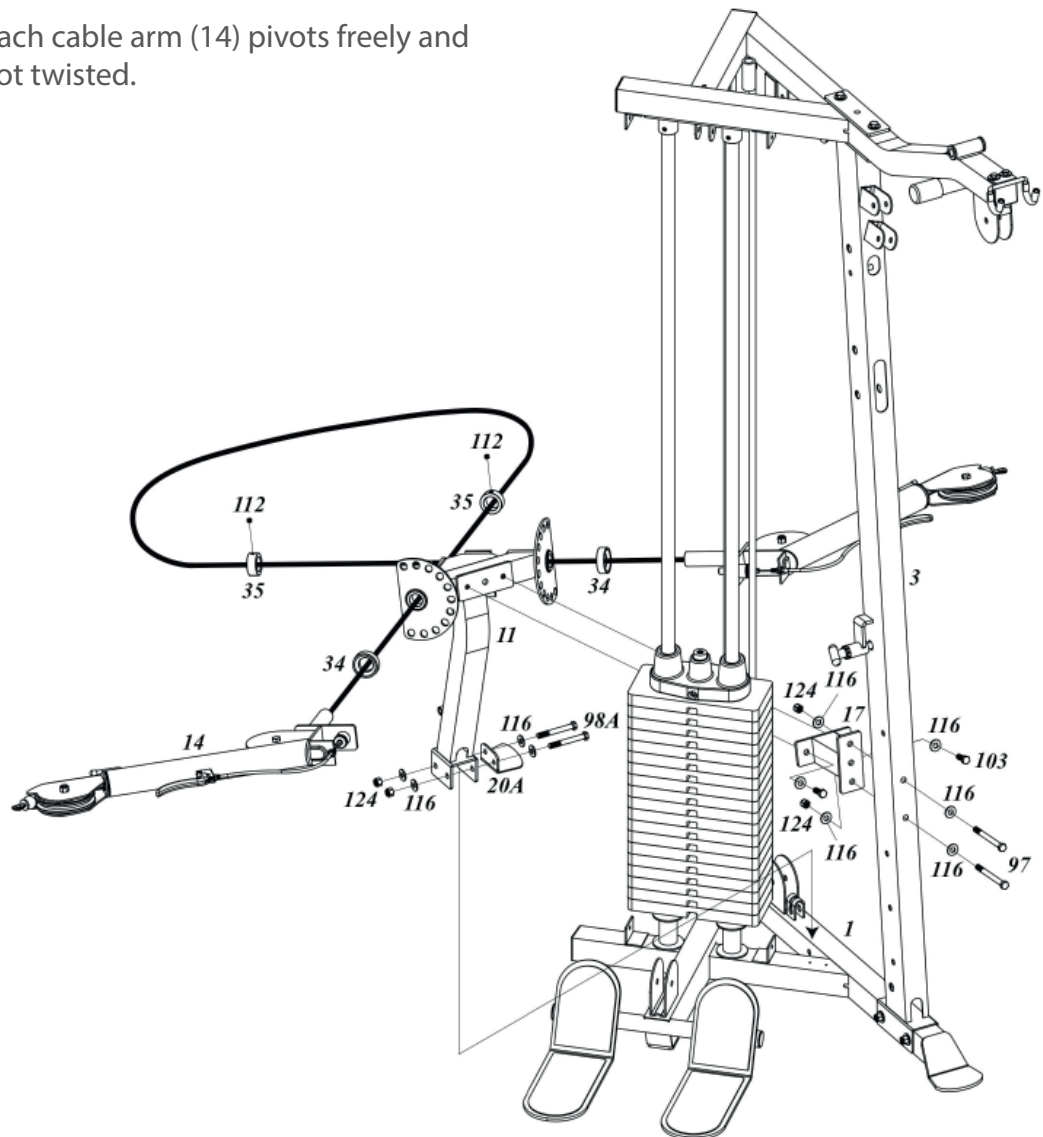

Step 4: Assembly of the Press Station

1. Attach the press arm support (13) to the top frame (2) by aligning the holes and inserting one bolt (95) with two washers (115) and one nylon nut (123).
2. Attach four end caps (68) to the press arm support (13).
3. Attach press arm (7) to the press arm support (13) by aligning the holes and inserting the press arm axle (28).
4. Tighten the two pre-assembled set screws (112) on the press arm (7).
5. Make sure the longer pop pin (85) is seated in one of the adjustment holes on the press arm support (13).
6. Attach two end caps (69) to the press arm (7).

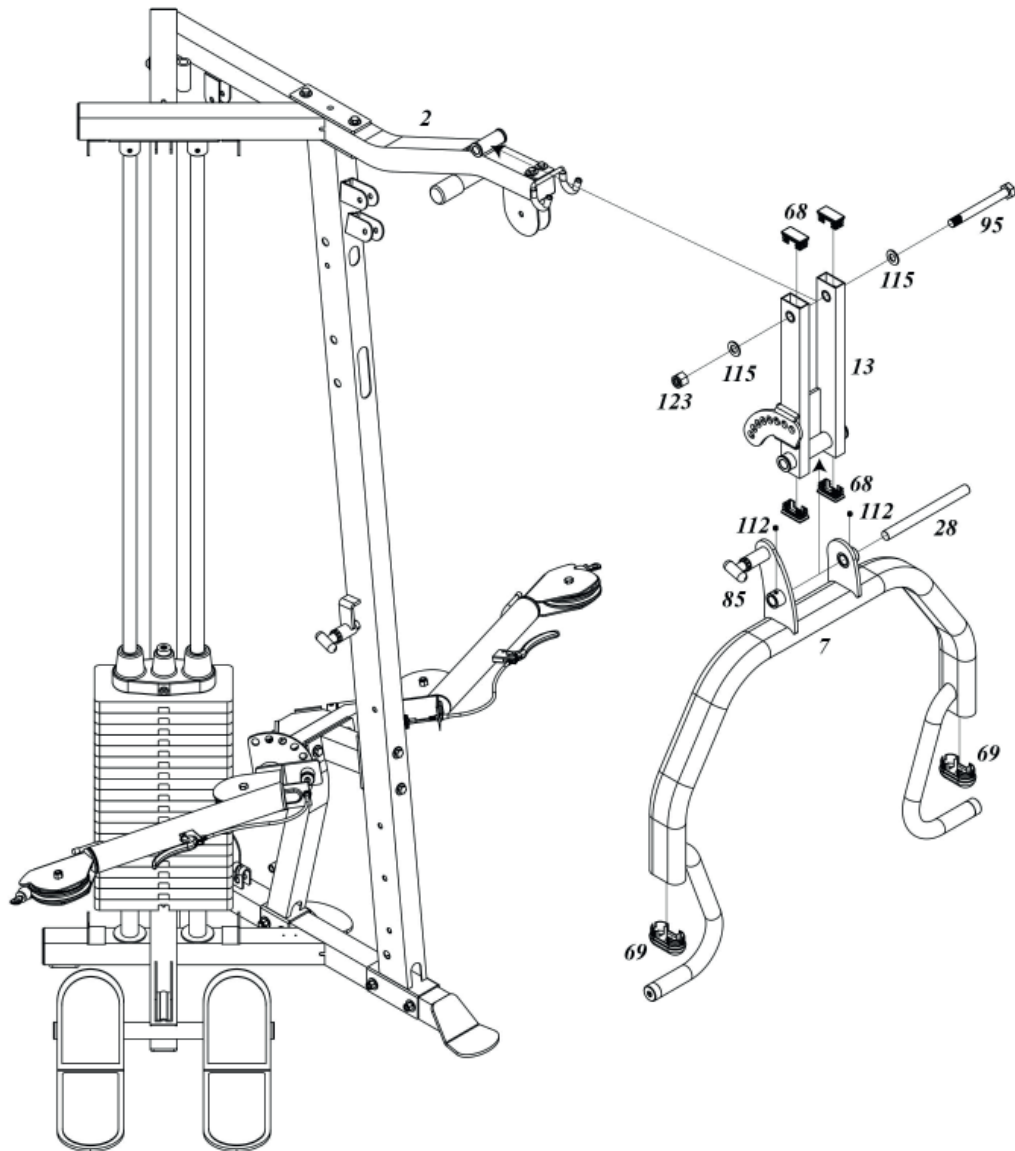

Step 5: Assembly of Seat and Back Pad

1. Assemble the seat frame (9) to the front upright (3) by using three bolts (99), six washers (116) and three nylon nuts (124).
2. Assemble the seat back adjuster (12) to the front upright (3) by using one bolt (99), two washers (116) and one nylon nut (124).

NOTICE

It may be necessary to tighten the bolt (99) and loosen it just enough to let the seat back adjuster (12) pivot FREELY.

3. Make sure the longer red pop pin (85) fits into the adjustment holes in the seat back adjuster (12).
4. Assemble the leg holder (16) to the seat back adjuster (12) by using two screws (104) and two washers (117) and tighten the screws.
5. Slide the two metal hinges (24), with the holes at the bottom, onto the axle welded on top of the seat back adjuster (12).
6. Assemble the back pad (48) to the metal hinges (24) by using two bolts (103) and two washers (116).
7. Assemble the leg extension handle (6) to seat adj. frame (8) by using two bolts (99), four washers (116) and two nylon nuts (124).
8. Assemble the seat pad (47) to the seat adj. frame (8) by using two bolts (102) and two washers (116).
9. Insert one end plug (68) into each end of the seat adj. frame (8).
10. Slide the seat adj. frame (8) into the seat frame (9).

NOTICE

The seat adj. frame (8) is held in place by a locking spring knob (84).

11. Assemble the leg extension arm (10) to the seat frame (9) by using two set screws (108), two spring washers (119) and two washers (117).
12. Insert a foam roller holder (27) into the tube on the seat adj. frame (8).
13. Slide a plastic washer (71) and a foam pad (49) onto the foam roller holder (27) with the flat side pointing to the outside on each side.
14. Attach one aluminum cap (72) to each end of the foam roller holder (27) and secure with one sunken head screw (106) each.
15. Repeat steps 12 to 14 for foam pads (49) on leg extension arm (10) and leg holder (16).

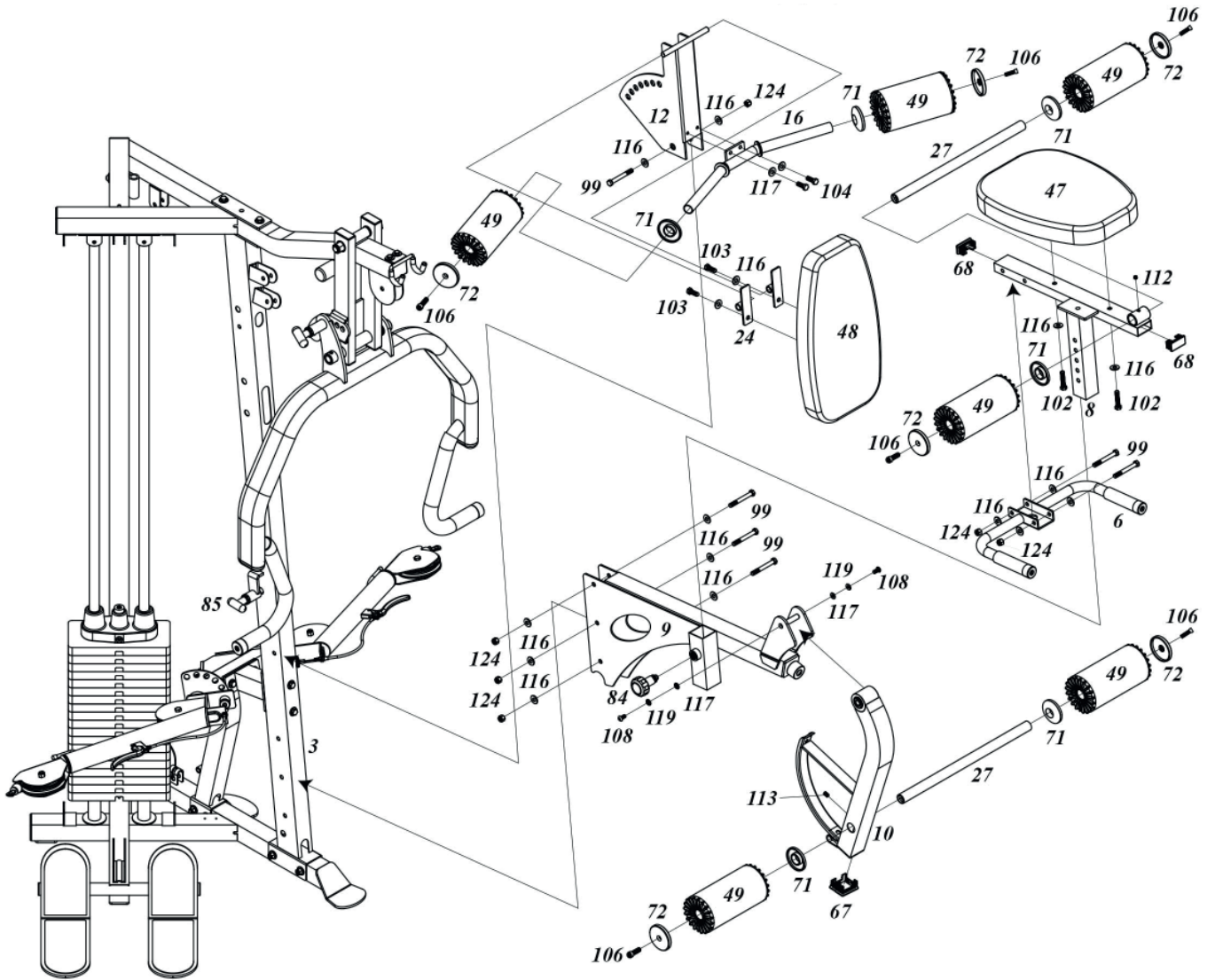

Step 6: Assembly of the Top Cable

NOTICE

Do not mount both pulleys T3 and T5 to one side. Assemble cables and pulleys simultaneously.

1. Grab the threaded end of the top cable (87) and run the cable over pulley T1. Assemble pulley T1 at the front of the top frame (2) by using one bolt (101) and one nylon nut (124), as shown in Fig T1.
2. Route the cable back to a pulley T2 and assemble it on the front upright (3) by using one bolt (101) and one nylon nut (124).
3. Route the cable over the top of pulley T2 and let it end on the underside of the pulley.
4. Route the cable to the press arm support (13).
5. Assemble two pulleys in parallel by using one bolt (99), two washers (116) and one nylon nut (124).
6. Route the cable to the top of pulley T3, around T3 to underside of pulley T4 on the front upright (3). Assemble pulley T4 by using one bolt (101) and one nylon nut (124).
7. Route the cable entering the underside of T4, ending on top and forwarding to pulley T5 on the press arm support (13). Route the cable over the top of pulley T5, ending on the underside.
8. Route the cable to pulley T6. Assemble pulley T6 to the front upright (3) by using one bolt (99), two washers (116), two bushings (77) and one nylon nut (124). Route the cable to the underside of pulley T6.
9. Route the cable over the top of pulley T7. Assemble pulley T7 to the rear bracket on the top frame (2) by using one longer bolt (100) and one nylon nut (124).
10. Assemble pulley T8 to the closed end of the adjustable pulley block (18) by using one hex bolt (101) and one nylon nut (124). Hang this adjustable pulley block (18) by routing the cable to the underside of the pulley T8.
11. Route the cable over the top of pulley T9. Assemble pulley T9 to the top frame (2) by using one bolt (101) and one nylon nut (124).
12. Route the cable through the floating pulley block (21). Orient the floating pulley block (21) with the threaded end up and flat side down. Fasten the threaded installed set screw (111) to the bracket welded on top frame (2). Insert pulley T10 into the floating pulley block (21), making sure the cable runs to the underside. Secure the pulley by using one bolt (101) and one nylon nut (124).

► **ATTENTION**

+ If you purchased the optional leg press, please orient the floating pulley block (21) with the threaded end down and the flat side up (as described in the leg press manual).

13. Route the cable over pulley T11. Assemble pulley T11 to the top frame (2) by using one bolt (101) and one nylon nut (124).
14. Route the cable through the looped end of the selector pin lanyard. Screw the threaded end of the top cable into the top plate (about half way down).

ⓘ **NOTICE**

The threaded end of the cable is an adjustment point but should always have at least one third of the threads screwed into the top plate.

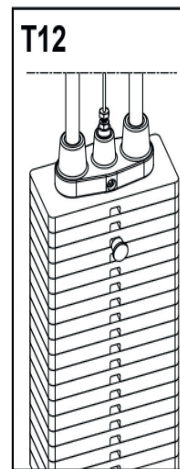
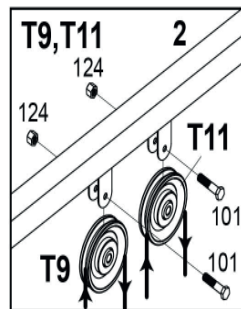
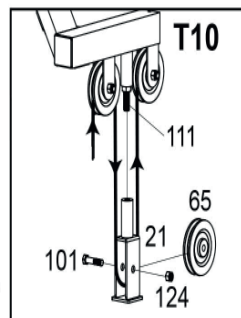
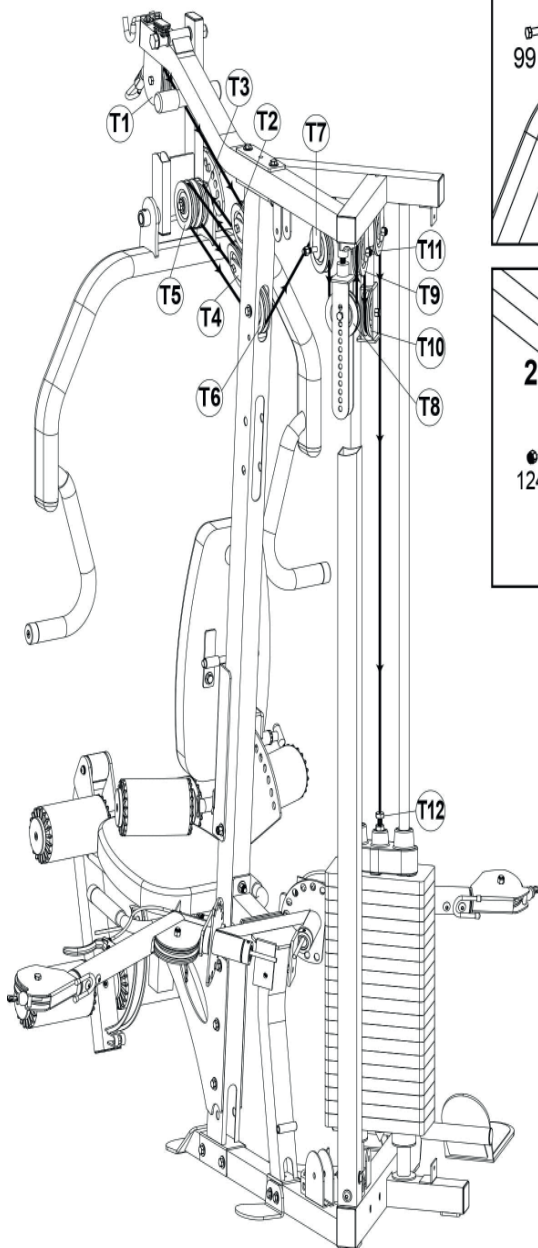
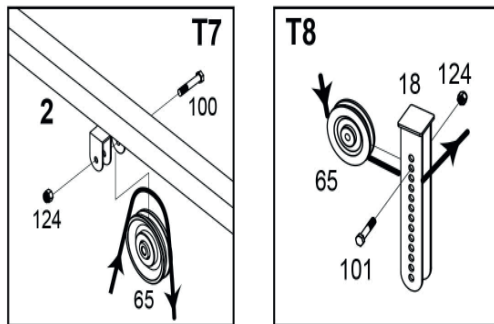
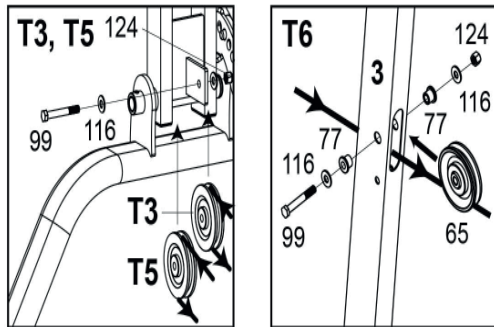
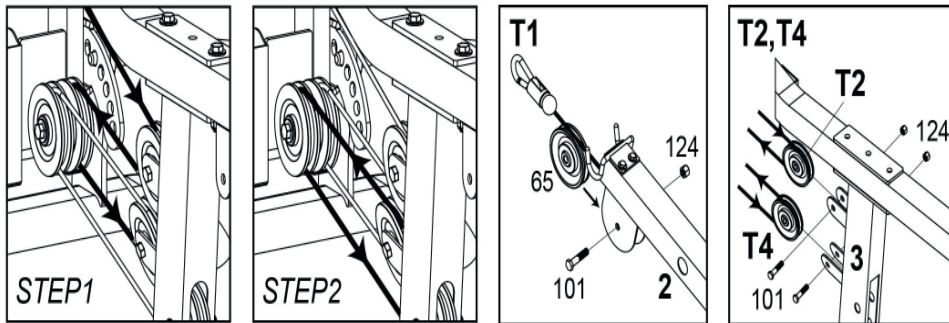
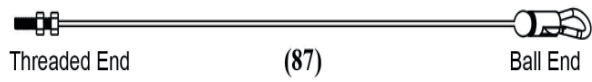

Step 7: Assembly of the Ab Cable

1. Route the steel ball end of the ab cable (88) through the slot in the front upright (3) and attach two pulleys in the slot (as shown in Fig. A1) by using two bolts (99), four washers (116), four bushings (77), and two nylon nuts (124).

ⓘ NOTICE

The cable should run from the bottom of the upper pulley in A1 up to the pulley A2.

2. Route the cable over the pulley A2. Assemble pulley A2 to the top frame (2) by using one bolt (101) and one nylon nut (124).
3. Route the cable under pulley A3. Assemble pulley A3 to a double pulley block (19) by using one bolt (101) and one nylon nut (124).
4. Route the cable up and over pulley A4. Assemble pulley A4 to the top frame (2) by using one bolt (100) and one nylon nut (124).
5. Route the cable under pulley A5. Assemble pulley A5 to a double pulley block (19) by using one bolt (101) and one nylon nut (124).
6. Assemble a pulley A6 to the open end of the adjustable pulley block (18) by using one bolt (101) and one nylon nut (124).

ⓘ NOTICE

We recommend the third hole from below. This can be adjusted later if needed.

7. Route the cable over top of this pulley and then down to c.

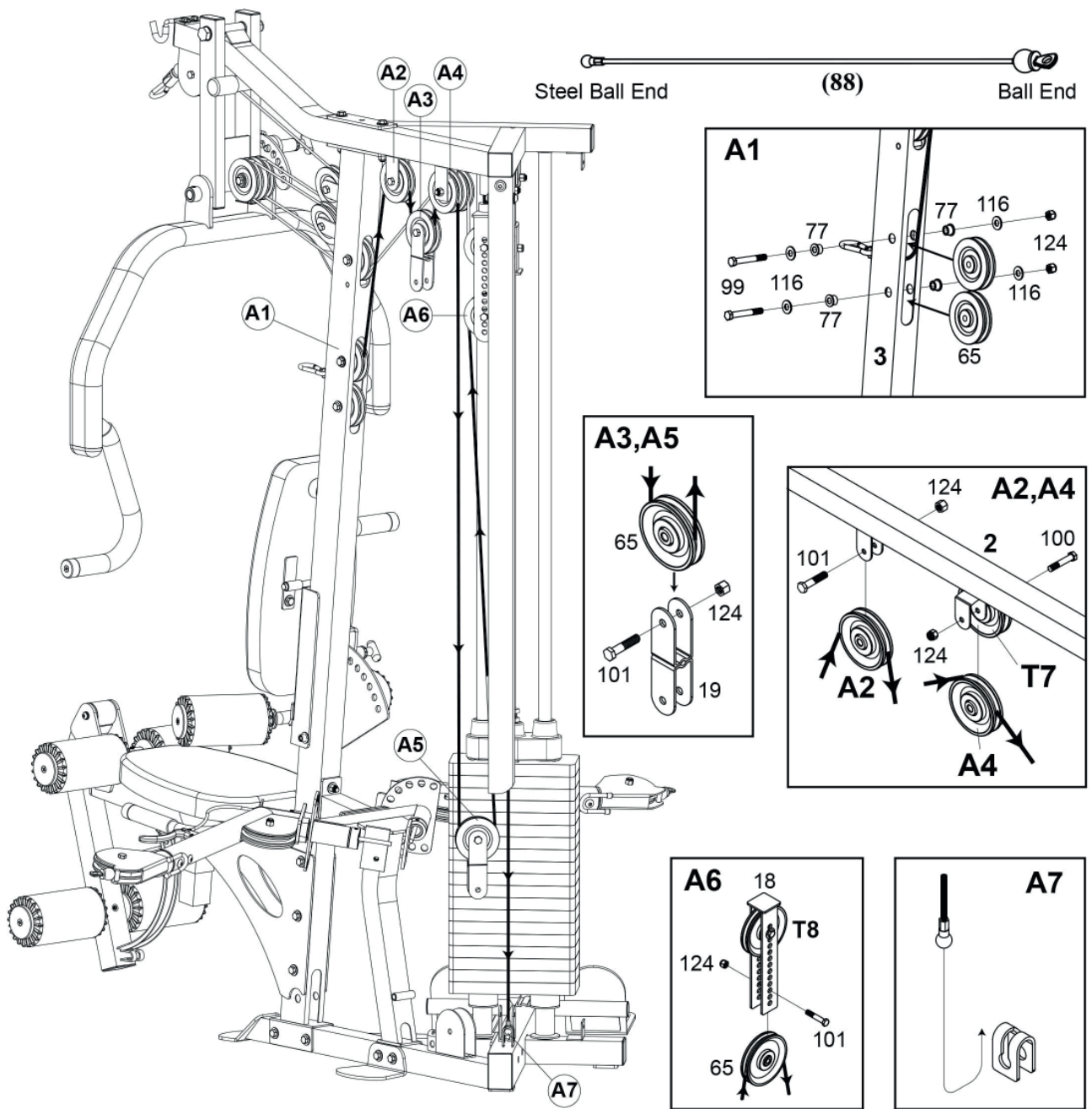

Step 8: Assembly of the Lower Cable

1. Route the steel ball end of the lower cable (89) under pulley L1. Assemble pulley L1 at the front of the low pull station by using one bolt (101) and one nylon nut (124).
2. Route the cable to pulley L2. Assemble pulley L2 to the base frame (1) by using one bolt (101) and one nylon nut (124).
3. Route the cable underneath L2 and up to pulley L3. Assemble pulley L3 to the bottom of the double pulley block (19) by using one bolt (101) and one nylon nut (124).
4. Route the cable down to pulley L4. Assemble pulley L4 to the base frame (1) by using one bolt (101) and one nylon nut (124).
5. Route the cable underneath L4 and pulley L5. Assemble pulley L5 to the slot in the bottom of the front upright (3) by using one bolt (99), two washers (116), two bushings (77), and one nylon nut (124).
6. Connect the steel ball end of the cable to the receptor bracket L6 welded to the leg extension arm (10).

Ball End (89) Steel Ball End

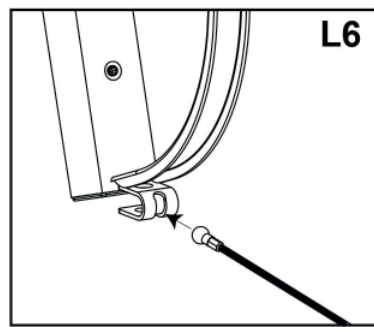
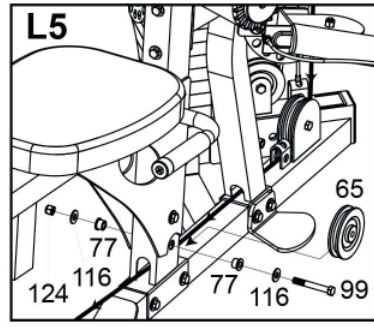
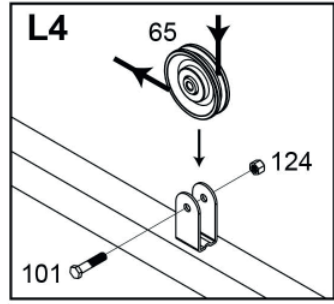
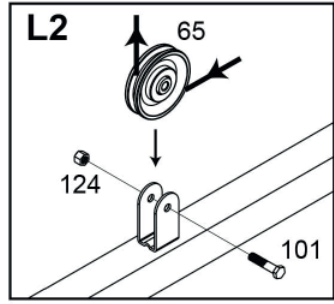
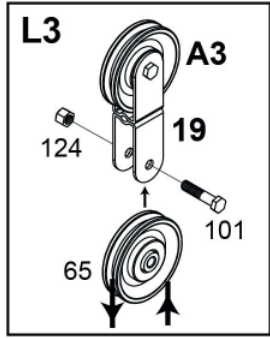
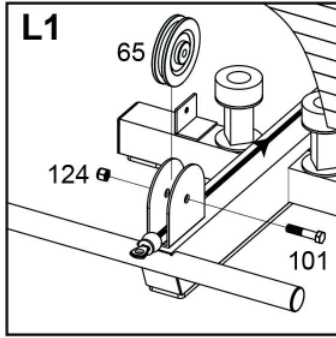
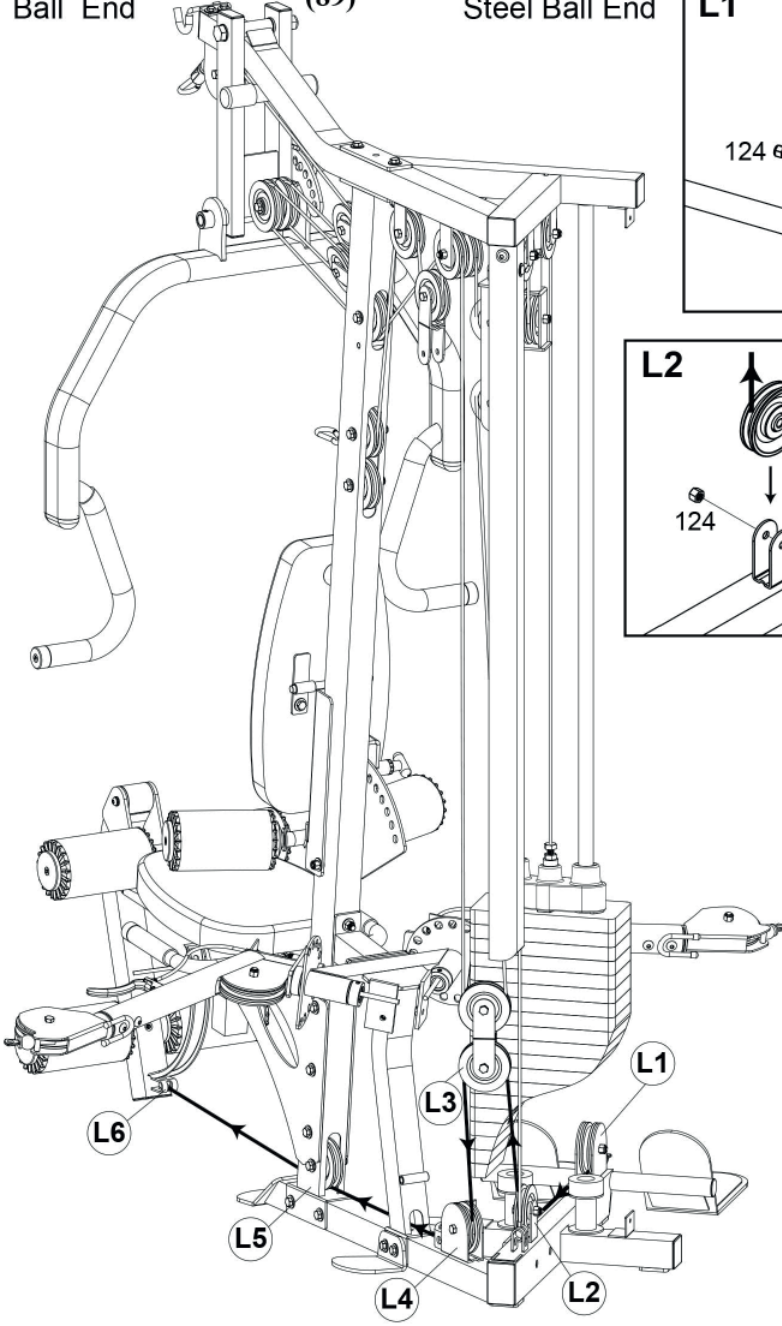

Step 9: Assembly of the Connect Cable

1. Hook the steel ball end of the connect cable (90) to the receptor C1 welded to the base frame (1).
2. Route the cable up and over pulley C2. Assemble pulley C2 to the bottom of the double pulley block (19) by using one bolt (101) and one nylon nut (124).
3. Screw the threaded end of the cable half way into the threaded receptor on the pulley block (20). The threaded end of the cable is an adjustment point but should always have at least one third of the threads screwed into the pulley block (20).

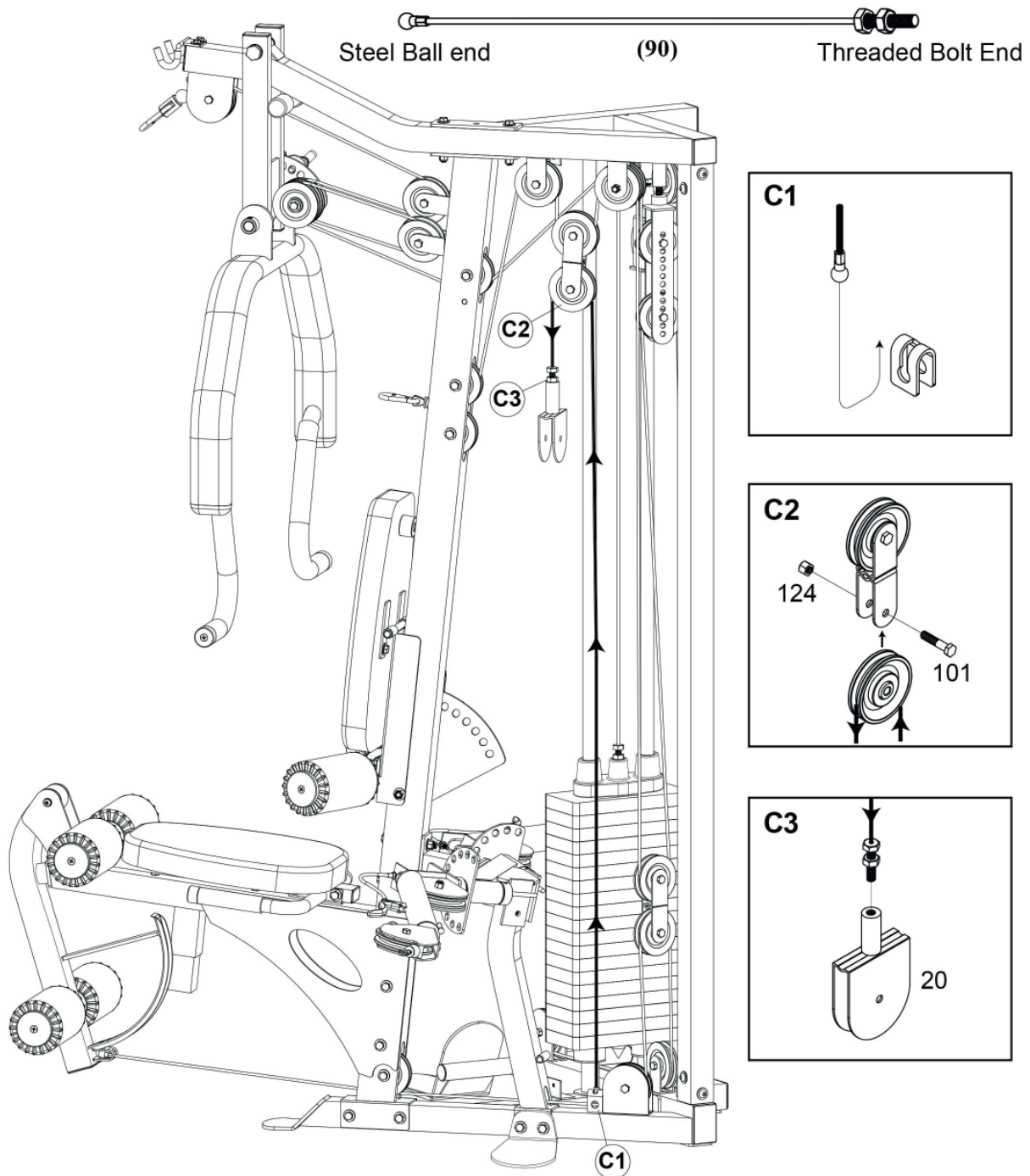

Step 10: Assembly of the Cable Arm Cable

① NOTICE

The cable arm cable (91) is already routed through the cable arms (14).

1. Assemble pulleys P3 and P7, along with their pulley guide brackets (32) to the cable arm assembly (11) by using one bolt (101) each.
2. Route the cable above these pulleys. Tighten these nuts, making sure the pulley guide brackets (32) do not rub against the cable.
3. Continue routing, on both sides, down and around pulleys P4 and P6. Assemble pulleys P4 and P6 to the base of the cable arm assembly (11) by using one bolt (96), two pulley guide brackets (32) and one nylon nut (124). Tighten this nut, making sure the pulley guide brackets (32) do not rub against the cable.
4. Route the cable up to pulley P5. Assemble pulley P5 inside the pulley block (20) by using one bolt (101), the cable guide plate (25) and one nylon nut (124). Loosely hook the cable guide plate (25) to the connect cable (90), directly behind that.

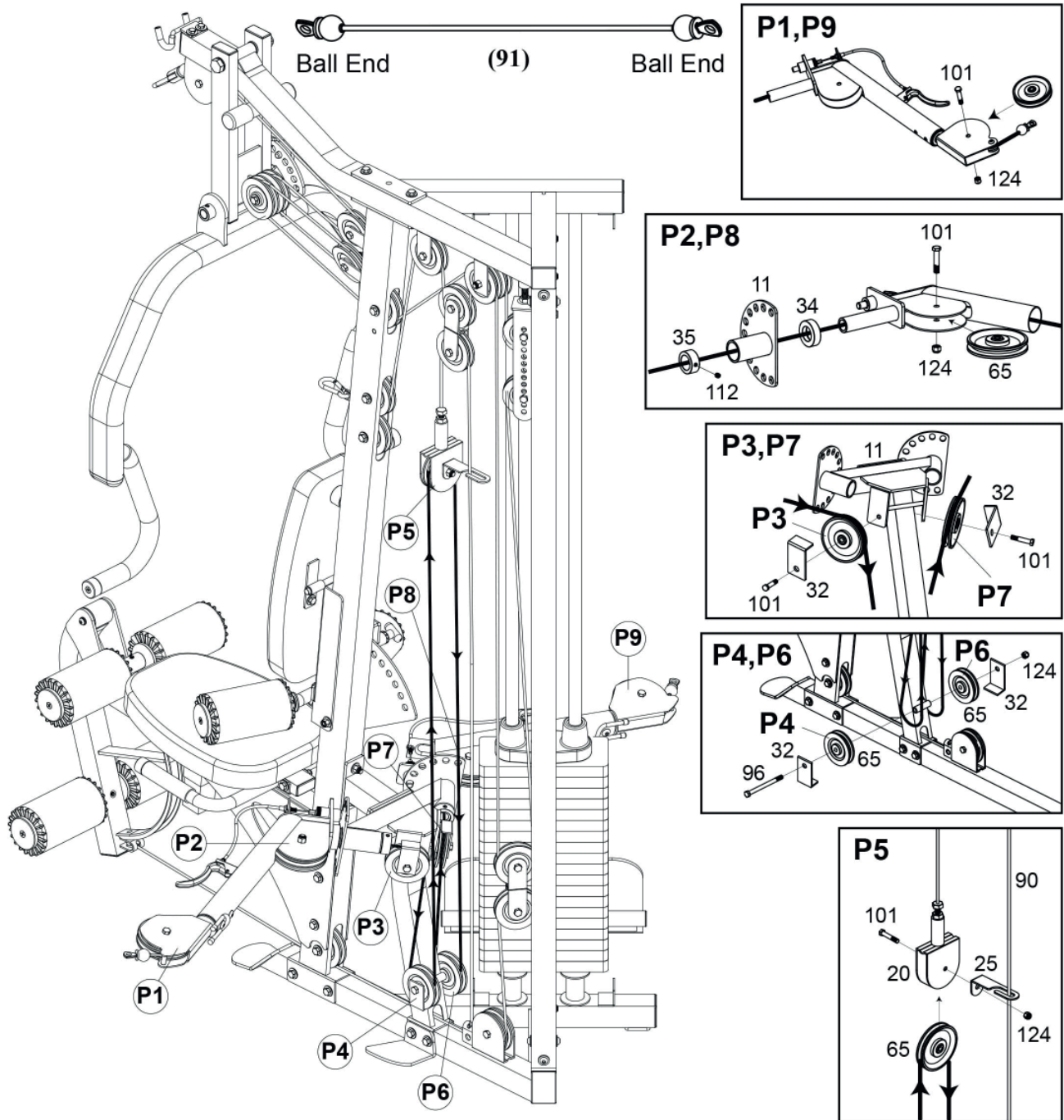

Step 11: Assembly of the Weight Stack Shrouds

1. Tighten all bolts, starting with the bolts at the base of the main frame.
2. Attach the weight stack shrouds (26) to the tabs welded on base frame (1) and top frame (2) by using four round bolts (104) and four washers (117).

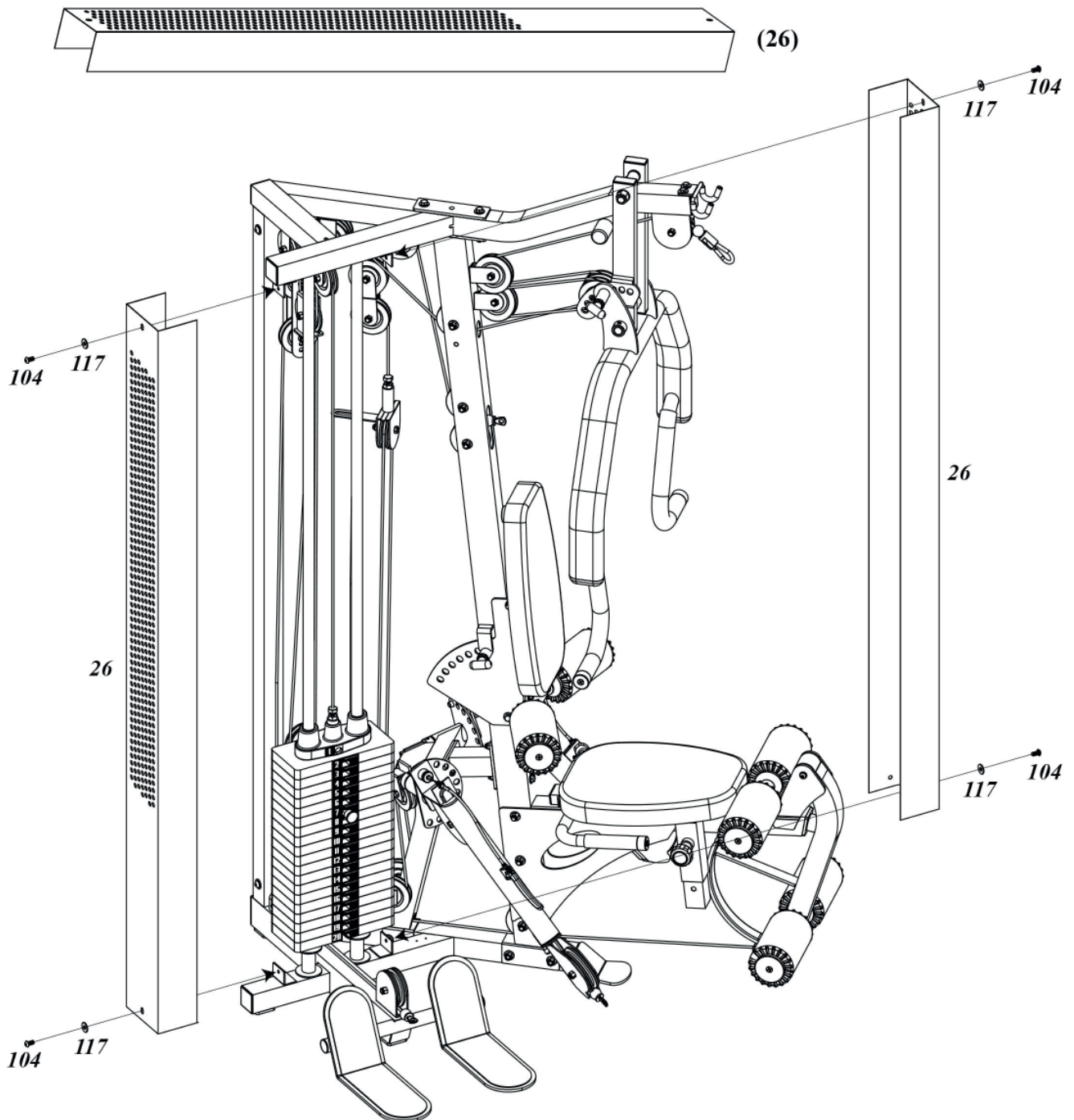

Step 13: Cable Adjustment of GX Strength Training System

NOTICE

The cables should be tightened to the point just before the top plate lifts off the stack. If the top plate is not resting on the stack, you need to add length. If there is slack in the cables, you need to shorten the cables.

1. For minor adjustments: adjust the screw ends on the top cable (at the top plate), the low cable (where it screws into the pulley block) or the bench press cable (where it screws into the pulley block with stopper). These ends of these cables must be screwed in at least 1/3 of their length for safety purposes. Once you are done with these adjustments, lock them into place by using the jam nuts.
2. For broader adjustments: move the bottom pulley towards the center of the adjustable pulley block (18) to decrease length (takes up slack). Move the bottom pulley outwards to gain cable length.
3. Adjust the adjustable stoppers in the top frame so that they just touch the adjustable pulley block (18). The adjustable stoppers (welded on the top frame) support the function of the gym by eliminating the need to engage all cables in any given exercise routine.

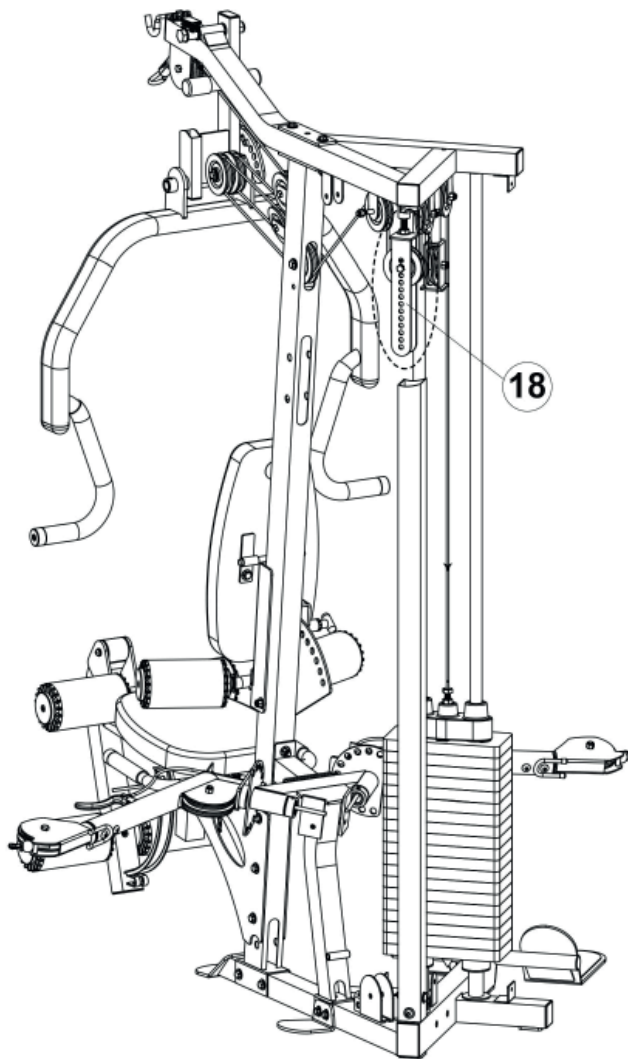

2.4 Scope of Delivery: Leg Press

The scope of delivery consist of the following parts. At the beginning, check whether all parts and tools belonging to the device are included in the scope of delivery and whether damage has occurred. In the event of complaints, the contractual partner must be contacted directly.

⚠ CAUTION

If parts of the scope of delivery are missing or damaged, the assembly must not be carried out.

ℹ NOTICE

The BodyCraft GX leg press is an optional accessory for the GX multi-gym. The leg press is not included in the scope of delivery of the multi-gym and must be purchased separately.

NO.	DESCRIPTION	QTY.
224	1/2" X 4-1/4" HEX BOLT	2
225	1/2" X 3-1/4" HEX BOLT	2
227	3/8" X 4" HEX BOLT	1
229	3/8" X 3" HEX BOLT	3
230	3/8" X 1-3/4" HEX BOLT	2
231	3/8" X 2-3/4" HEX THREADED BOLT	2
232	3/8" X 1" HEX THREADED BOLT	2
235	1/2" WASHER	7
236	3/8" WASHER	12
237	1/2" NYLON NUT	3
238	3/8" NYLON NUT	6
242	3/8" X 3-1/2" HEX BOLT	1

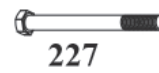
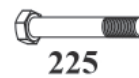
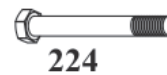

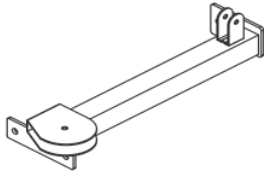

(201) BASE STABILIZER

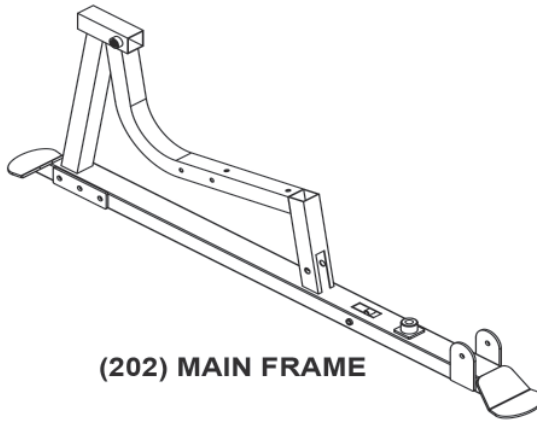

(202) MAIN FRAME

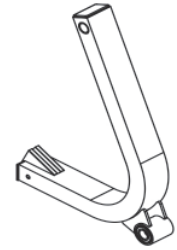

(203) LEG PRESS SUPPORT

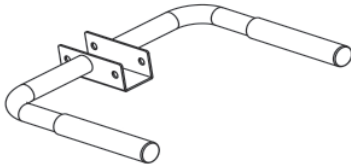

(204) SEAT HANDLE

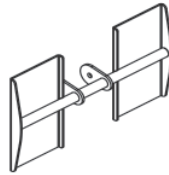

(206) FOOT PLATE



(207) RUBBER STOPPER



(208) ϕ 25mm AXLE

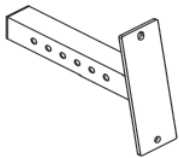

(205) BACK PAD ADJUSTER



(209) ϕ 3/4" AXLE



(210) COLLAR

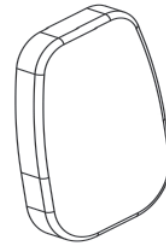

(213) BACK PAD

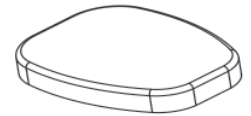

(214) SEAT PAD



(215) 114mm PULLEY



(216) 90mm PULLEY X 3pcs



(217) LEG PRESS CABLE



(218) LOCKING SPRING KNOB

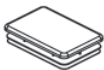

(219) 50 X 75mm RECT. PLUG



(223) LEG PRESS BUSHING X 2pcs



(241) CAP FOR NUT X 4pcs

2.5 Assembly: Leg Press

Before assembly, take a close look at the individual assembly steps shown and carry out the assembly in the order given.

i NOTICE

- + First loosely screw all parts together and check that they fit properly. Tighten the screws using the tool only when you are instructed to do so.
- + If you have difficulty recognising the graphics, we recommend that you open and/or download the PDF instructions stored in the webshop on your end device (e.g. smartphone, tablet or PC). There you have the option of zooming in closer. Please note that the Adobe Acrobat Reader programme must be installed on your end device in order to open the file.

Step 1: Assembly of the Base Stabilizer

Attach the base stabilizer (201) to the base frame of the multi-gym (1) with two hex bolts (225), three washers (235) and one nylon nut (237).

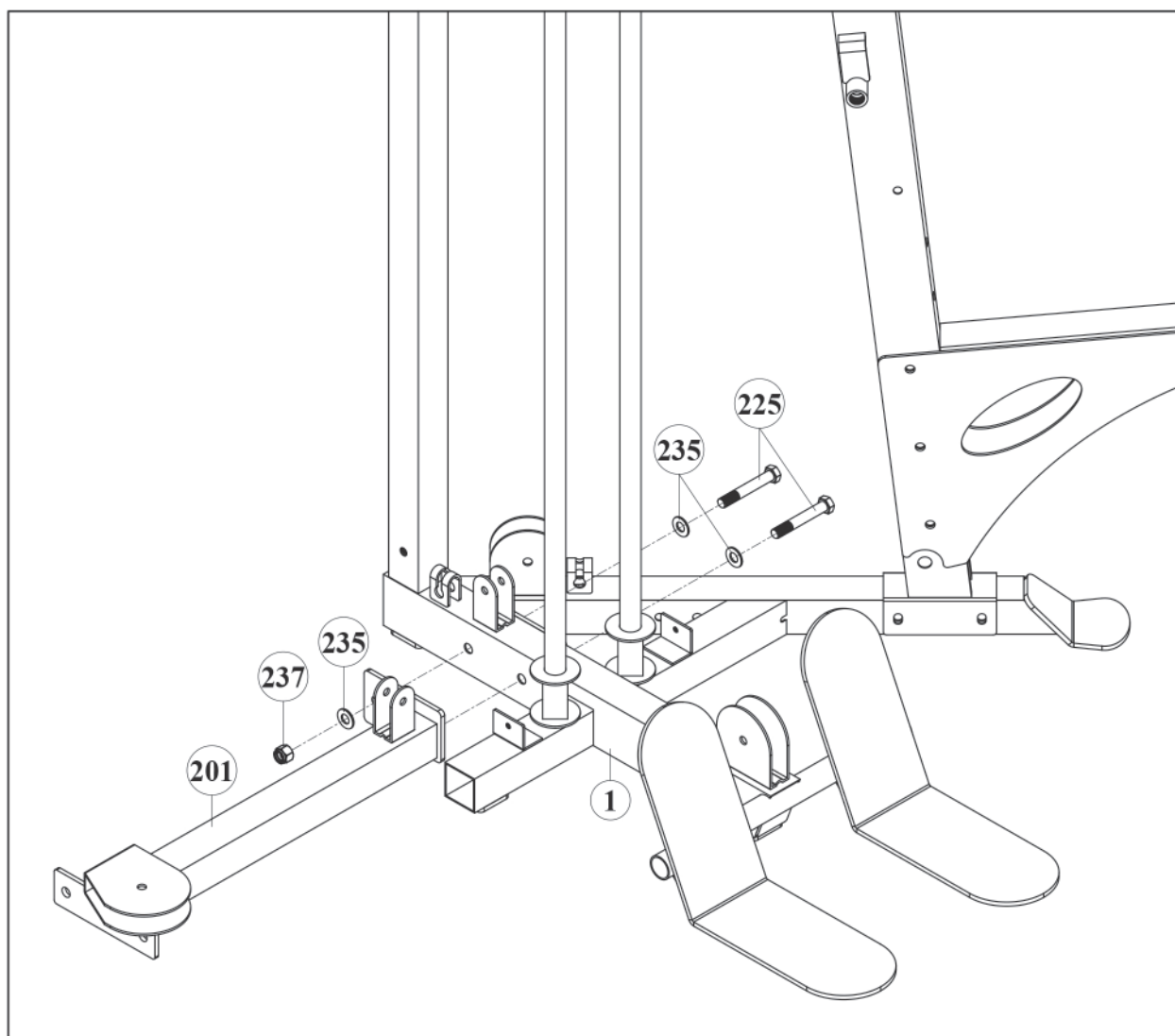

Step 2: Assembly of the Main Frame and Leg Press Support

1. Attach the main frame (202) to the base stabilizer (201) with two hex bolts (224), four washers (235) and two nylon nuts (237).
2. Attach the plug (219) to the leg press support (203).
3. Insert the 25mm axle (208) into the leg press support (203), then attach the leg press support (203) to the main frame (202) with two collars (210) [inside the brackets on the main frame], two hex threaded bolts (226) and two washers (235). Tighten the bolts (226) and cap with two end caps (241).
4. Insert the 3/4" axle (209) into the upper hole in the leg press support (203), then attach the foot plate (206) to the leg press support (203) with two hex threaded bolts (226) and two washers (235). Tighten the bolts (226) and cap with two end caps (241).

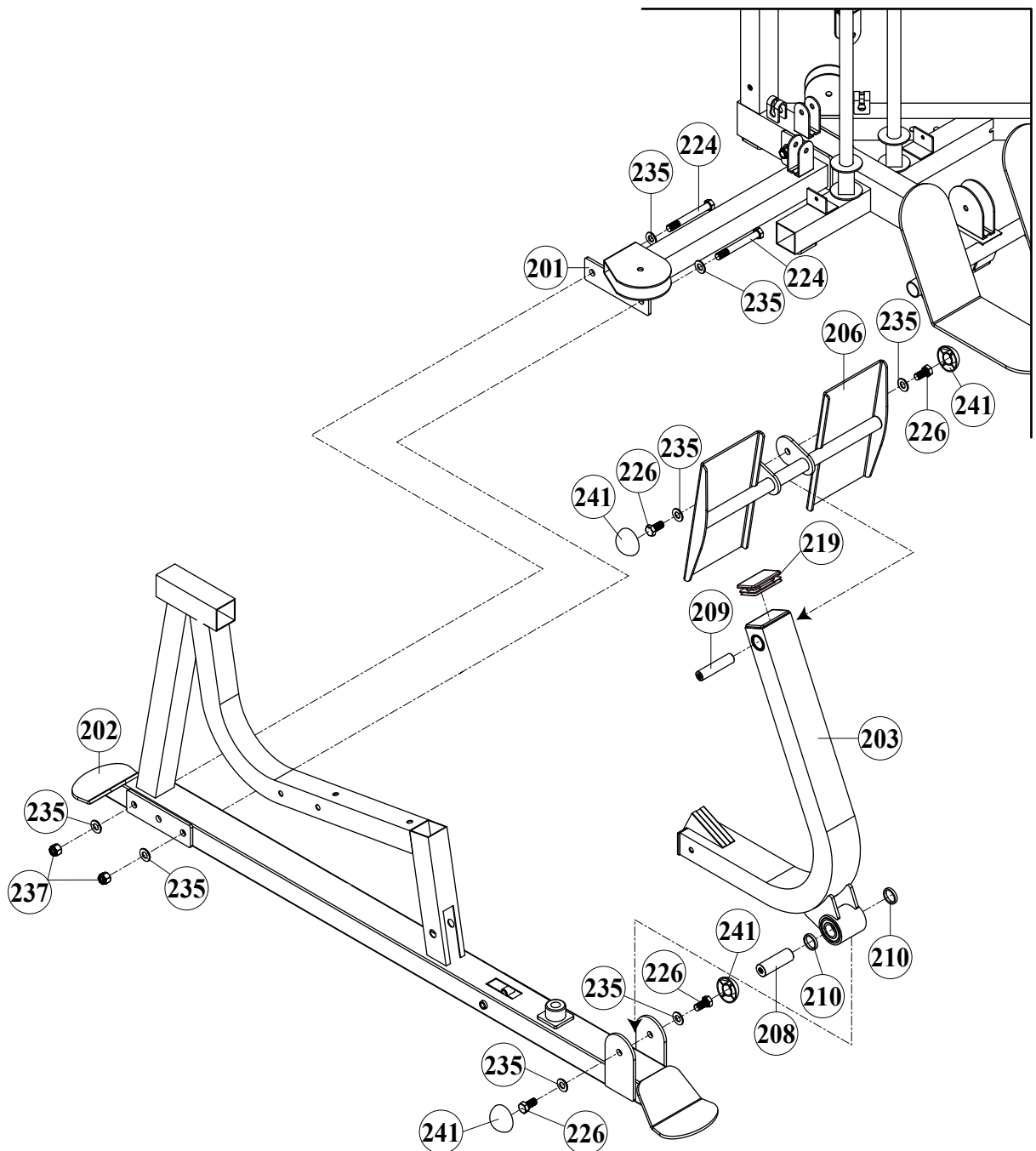

Step 3: Assembly of the Pads and Seat Handle

1. Attach the seat handle (204) to the main frame (202) with two hex bolts (229), four washers (236) and two nylon nuts (238).
2. Attach the seat pad (214) to the main frame (202) with two hex threaded bolts (231) and two washers (236).
3. Attach the back pad (213) to the back pad adjuster (205) with two hex bolts (232) and two washers (236).
4. Slide the back pad adjuster (205) into the main frame (202) and lock it into place with the spring knob (218).



CAUTION

Make sure the spring knob (218) always engages in one of the adjustment holes when adjusting the position.

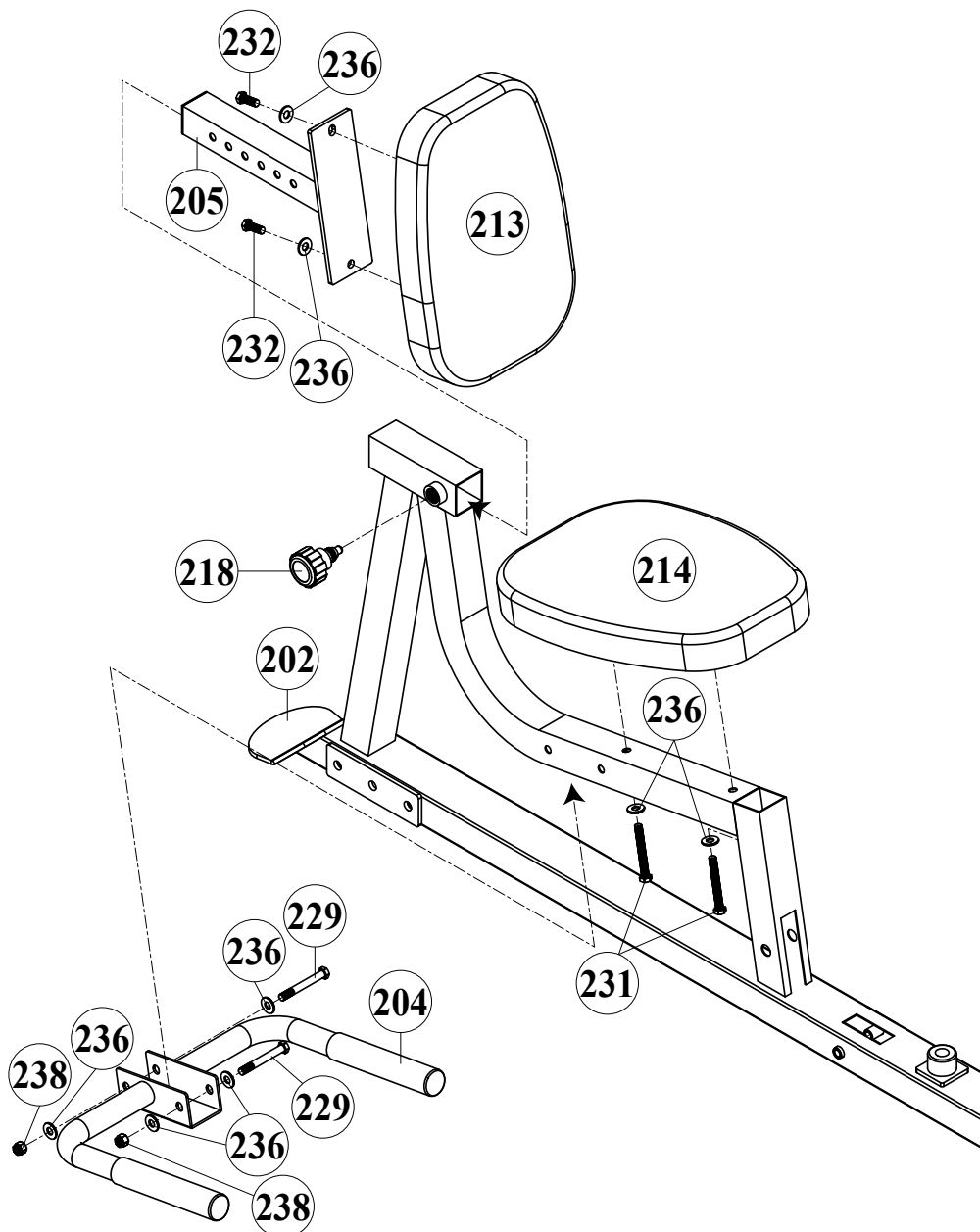

Step 4: Assembly of the Leg Press Cable, Part 1

ⓘ NOTICE

The cable and pulleys must be assembled simultaneously as you go.

1. Locate the floating pulley block (21) assembled to the GX multi-gym and unscrew the floating pulley block (21).
2. Screw the rubber stopper (207) into the top frame (2) in place of the floating pulley block (21).
3. Remove the attached pulley (101) by loosening the bolt (65) and nut (124) and flip the floating pulley block (21) so that the flat end of the floating pulley block (21) is resting against the rubber stopper (207), see fig. 1. Reattach the pulley (101) with the same bolt (65) and nut (124).
4. Screw the threaded end of the leg press cable (217) halfway into the floating pulley block (21).

ⓘ NOTICE

This is an adjustment point to loosen or tighten the cable. The cable must always be screwed in at least one third of the threaded end.

5. Pass the cable under one 90mm pulley (216) and attach the pulley to the base stabilizer (201) with one hex bolt (230) and one nylon nut (238), see fig. 2.

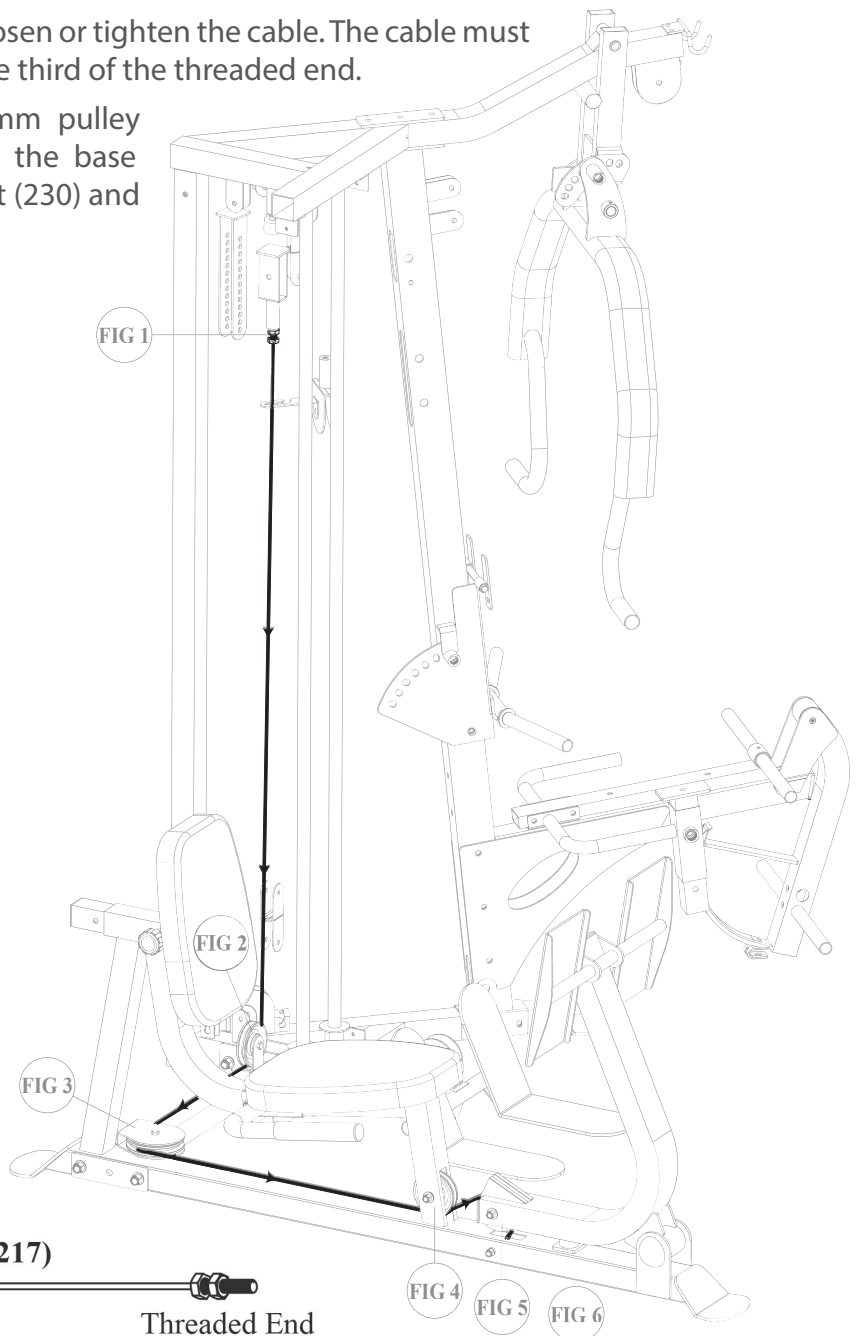
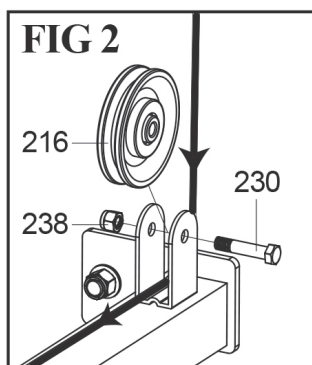
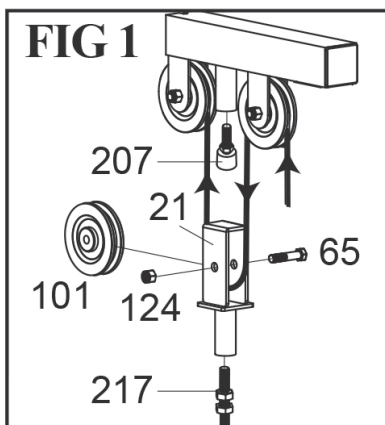

Leg Press Cable (217)

Flat End

Threaded End

Step 5: Assembly of the Leg Press Cable, Part 2

1. Pass the cable around one 114mm pulley (215) and attach the pulley to the base stabilizer (201) with one hex bolt (230), see fig. 3.
2. Pass the cable under one 90mm pulley (216) and attach the pulley to the main frame underneath the seat (202) with one hex bolt (229), two washers (236), two leg press bushings (223) and one nylon nut (238), see fig. 4.
3. Pass the cable over one 90mm pulley (216) and attach the pulley to the leg press support (203) with one hex bolt (242), two washers (236) and one nylon nut (238), see fig. 5.
4. Attach the flat end of the cable to the bottom of the main frame (202) with one hex bolt (227) and one nylon nut (238), see fig. 6.
5. If the cable is too tight or too loose, readjust the cable at the threaded end.

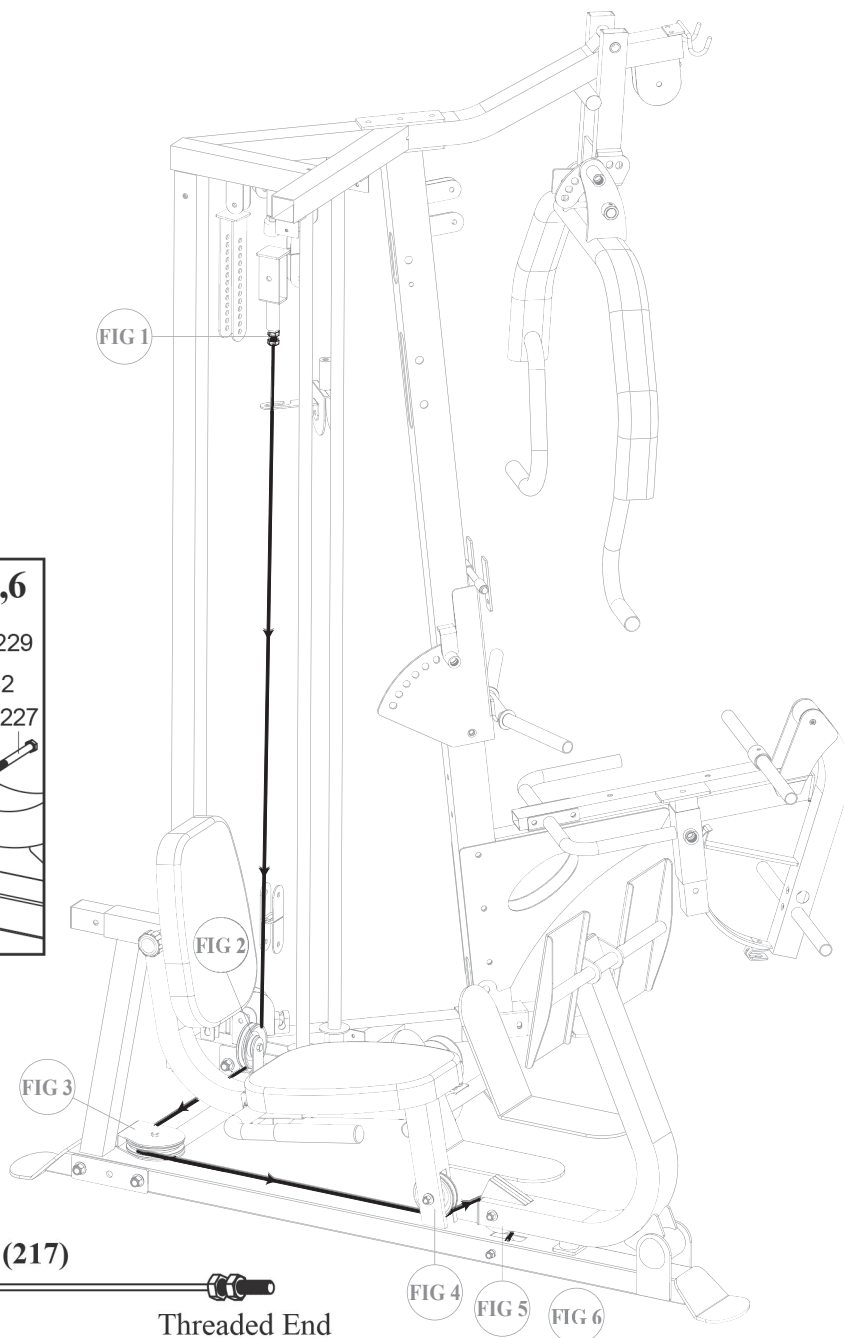
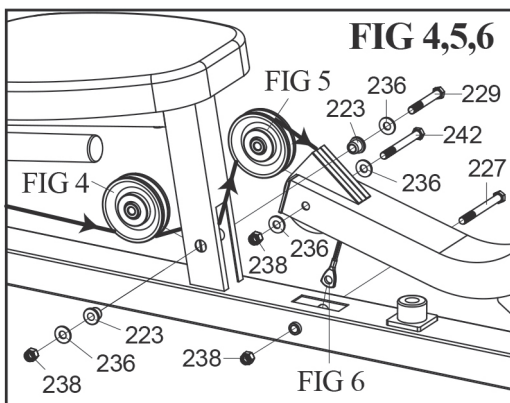
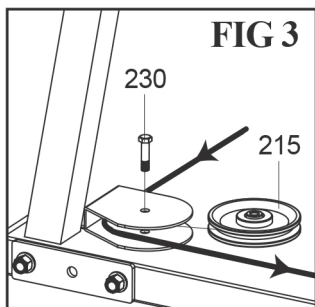

Leg Press Cable (217)

Flat End

Threaded End

3.1 General Instructions



WARNING

- + The storage location should be chosen so that improper use by third parties or children can be prevented.
- + If your equipment does not have transportation wheels, the equipment must be disassembled before transportation.



ATTENTION

- + Make sure that the equipment is protected from moisture, dust and dirt in the selected storage location. The storage location should be dry and well ventilated and have a constant ambient temperature between 10°C and 35°C.

4.1 General Instructions



WARNING

- + Do not make any improper changes to the equipment.



CAUTION

- + Damaged or worn components may affect your safety and the life of the equipment. Therefore, immediately replace damaged or worn components. In such a case, contact the contract partner. The equipment must not be used until it has been repaired. If necessary, use only original spare parts.

► ATTENTION

- + In addition to the instructions and recommendations for maintenance and care given here, additional service and/or repair work may be necessary; this must only be carried out by authorised service technicians.

4.2 Faults and Fault Diagnosis

The equipment undergoes regular quality controls during production. Nevertheless, faults or malfunctions may occur. Frequently, individual parts are responsible for these disturbances, an exchange is usually sufficient. Please refer to the following overview for the most common errors and how to correct them. If the equipment still does not function properly, contact your contract partner.

Fault	Cause	Solution
Grinding noises	Cables or pulleys do not run smoothly or are damaged	+ Visual inspection of the cable routing or the pulley guide + If damaged, replace the defective part
Weight hanging in the air	Cable tensioned too tight	Readjust cable tension
Cable without tension	Cable too loose	+ Check cable routing + Readjust cable tension
Squeaking & cracking noises	Screw connections loosened or too tight	+ Check or lubricate screw connections* + Check cable routing
Unit wobbles	+ Uneven ground + Loose screw connections	+ Align unit + Tighten screw connections
Heavy draught	+ Weight holders/guide rods too dry + Faulty cable routing	+ Lubricate guide rods* + Check cable routing

* With a grease-free silicone oil or silicone spray.

4.3 Maintenance and Inspection Calendar

To avoid damage from body sweat, the equipment must be cleaned with a damp towel (no solvents!) after each training session.

The following routine tasks must be performed at the specified intervals:

Part	Weekly	Monthly	Quarterly
Cables	C	I	
Screw connections		I	
Pulleys and cable routing		I	
Slide rails/Guide rods		I	
Weights			I
Cushions	C	I	
Legend: C = clean; I = inspect			

5 DISPOSAL

At the end of its operational life, this equipment cannot be disposed of in normal household waste. Instead, it must be disposed of via an recycling centre. Further information can be obtained from your local authority's recycling service.



The materials can be recycled as per their symbols. Through the reuse, recycling of materials or other forms of recovery of old equipment, you make an important contribution to the protection of the environment.

6 RECOMMENDED ACCESSORIES

To make your training experience even more efficient and pleasant, we recommend that you add suiting accessories to your fitness equipment. For training equipment like smith machines, weight benches or racks this could for example be a **floor mat**, which makes your fitness equipment stand more securely and also protects the floor from sweat but it could be also **additional weights, handles, foot straps** for leg exercises or **triceps ropes**. For some smith machines, there are also optional add-ons such as **leg presses** that make your workout even more intense and comprehensive.

Our range of accessories offers the highest quality and makes training even better. If you would like to find out more about compatible accessories, please go to the detail page of the product in our webshop (the easiest way is to enter the article number in the search field above) and go to the recommended accessories on this page. Alternatively, you can use the QR-code provided. Of course, you can also contact our customer service: by telephone, e-mail, in one of our branches or via our social media channels. We will be happy to advise you!



floor mat



chest strap



tricep and curl bar



triceps rope

7.1 Serial Number and Model Name

In order to provide you with the best possible service, please have the model name, article number, serial number, exploded drawing and parts list ready. The corresponding contact options can be found in chapter 9 of this operating manual.

NOTICE

The serial number of your equipment is unique. It's located on a white sticker. The exact position of this sticker is shown in the following illustration.

Enter the serial number in the appropriate field.

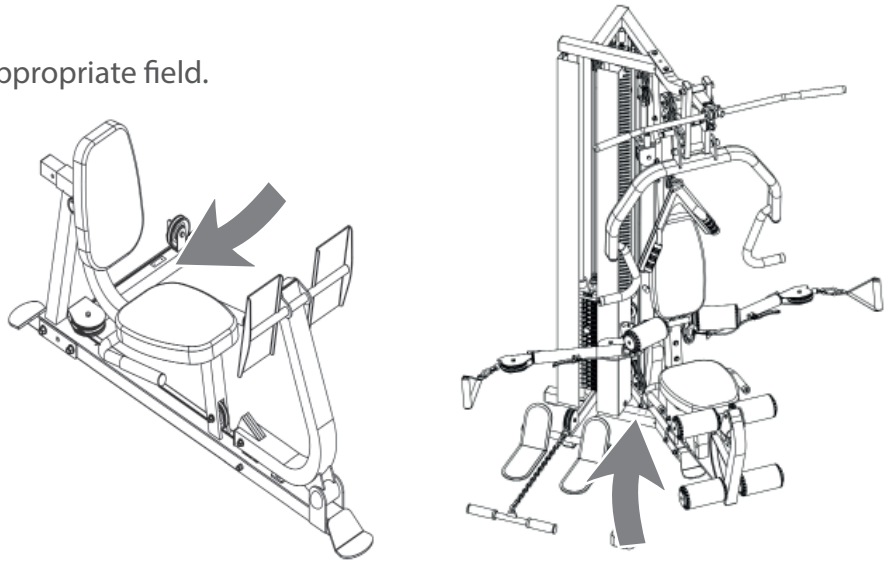

Serial number:

Brand / Category:

Model Name:

SKU:

7.2 Parts List: Multi-gym

No.	Name	Qty.
1	BASE FRAME	1
2	TOP FRAME	1
3	FRONT UPRIGHT	1
4	REAR UPRIGHT	1
5	GUIDE ROD	2
6	LEG EXTENSION HANDLE	1
7	PRESS ARM	1
8	SEAT ADJ. FRAME	1
9	SEAT FRAME	1
10	LEG EXTENSION ARM	1
11	CABLE ARM ASSEMBLY	1
12	SEAT BACK ADJUSTER	1
13	PRESS ARM SUPPORT	1
14	CABLE ARM	2
15	SWIVEL CABLE ARM END	2
16	LEG HOLDER	1
17	CABLE ARM CONNECTOR	1
18	ADJUSTABLE PULLEY BLOCK	1
19	DOUBLE PULLEY BLOCK	2
20	ADJ FLOATING PULLEY BLOCK	1
20A	STABILIZING PLATE	1
21	FLOATING PULLEY BLOCK	1
22	LAT BAR HOLDER	1
23	150LBS LONGER STACK SPACER	2
23A	200LBS SHORTER STACK SPACER	2
24	METAL HINGE	2
25	CABLE GUIDE PLATE	1
26	WEIGHT SHROUD	2
27	1" FOAM ROLLER HOLDER	2
28	PRESS ARM AXLE	1
29	LAT BAR	1

30	CURL BAR	1
31	LEG EXTENSION AXLE	1
32	PULLEY GUIDE BRACKET	4
33	CABLE ARM COLLAR	2
34	STEEL SPACER	2
35	AXLE COLLAR	2
36	COLLAR	2
37	HOOK PLATE	1
38	SELECTOR ROD	1
39	TOP PLATE	1
40	WEIGHT PLATE	19
40A	185L NONSLIP	2
41	235L NONSLIP	2
42	AB CRUNCH STRAP	1
43	SINGLE HANDLE	2
44	ANKLE STRAP	1
45	LINK	1
46	CLIP	5
47	SEAT PAD	1
48	BACK PAD	1
49	FOAM PAD	6
50	COVER OF FOAM PAD	6
51	1-1/4" X 430mm HAND GRIP	2
52	1" X 200mm ROUND HAND GRIP	2
53	1" X 345mm HAND GRIP	2
54	LAT BAR HOLDER COVER	2
55	1-1/4" X 140mm ROUND HAND GRIP	2
56	1-1/4" HAND GRIP	2
57	1" X 70mm HAND GRIP	2
58	CABLE ARM STOPPER	4
59	BEARING BASIN	4
60	BEARING	4
61	BEARING COVER	4
62	SEALING RING	2

63	1" T SHAPE END PLUG	2
64	114mm PULLEY	4
65	90mm PULLEY	29
66	50 X 75mm RECT. END CAP	1
67	50mm SQ. END CAP	5
68	25 X 50mm RECT. END CAP	6
69	40 X 80mm OVAL PLUG	2
70	1-1/4" ROUND END PLUG	2
71	PLASTIC WASHER	6
72	ALUMINUM CAP	6
73	1" ID PLASTIC GUIDE ROD HOLDER	2
74	1" ID STEEL BUSHING	4
75	3/4" ID BUSHING	2
76	5/8" ID BUSHING	2
77	3/8" ID BUSHING	8
78	LEG EXTENSION BEARING	2
79	RUBBER CUSHION	2
80	1/2" STOPPER	2
81	PRESS ARM STOPPER	2
82	SEAT PAD SUPPORT STOPPER	2
83	RUBBER STOPPER	1
84	LOCKING SPRING KNOB	1
85	LONGER POP PIN	1
86	SHORTER POP PIN	1
87	TOP CABLE	1
88	AB CRUNCH CABLE	1
89	LOWER CABLE	1
90	CONNECT CABLE	1
91	CABLE ARM CABLE	1
92	CLUTCH CABLE	2
93	CLUTCH LEVER OF CABLE ARM	2
94	SELECTOR PIN	1
95	5/8" X 5-1/2" HEX BOLT	1
96	3/8" X 4-3/4" HEX BOLT	1

97	3/8" X 4" HEX BOLT	2
98	3/8" X 3-1/8" HEX BOLT	2
98A	3/8" X 3-1/4" HEX BOLT	2
99	3/8" X 3" HEX BOLT	13
100	3/8" X 2-3/4" HEX BOLT	1
101	3/8" X 1-3/4" HEX BOLT	23
102	3/8" X 1-3/4" HEX THREADED BOLT	2
103	3/8" X 1" HEX THREADED BOLT	6
104	5/16" X 1/2" ROUND BOLT	8
105	TOP PLATE BOLT	1
106	5/16" X 1-1/4" SUNKEN HEAD SCREW	10
107	3/8" X 1/2" ROUND BOLT	4
108	5/16" X 5/8" SET SCREW	4
109	3/8" X 3/4" INNER HEX SCREW	8
110	M5 X 18mm ROUND HEAD SCREW	2
111	1/2" HALF THREADED STUD	1
112	5/16" X 1/4" SET SCREW	7
113	5/16" X 1/2" SET SCREW	2
114	M6 SET SCREW	2
115	5/8" WASHER	2
116	3/8" WASHER	54
117	5/16" WASHER	10
118	3/8" SPRING WASHER	4
119	5/16" SPRING WASHER	2
120	5/16" LARGER NUT	2
121	5/16" SMALLER NUT	8
122	24mm NYLON NUT	2
123	5/8" NYLON NUT	1
124	3/8" NYLON NUT	44
125	1/2" NUT	2
126	M5 NUT	2
127	4mm HEX WRENCH	1
128	5mm HEX WRENCH	1
129	GUIDE ROD MOUNT	1

7.3 Exploded Drawing: Multi-gym

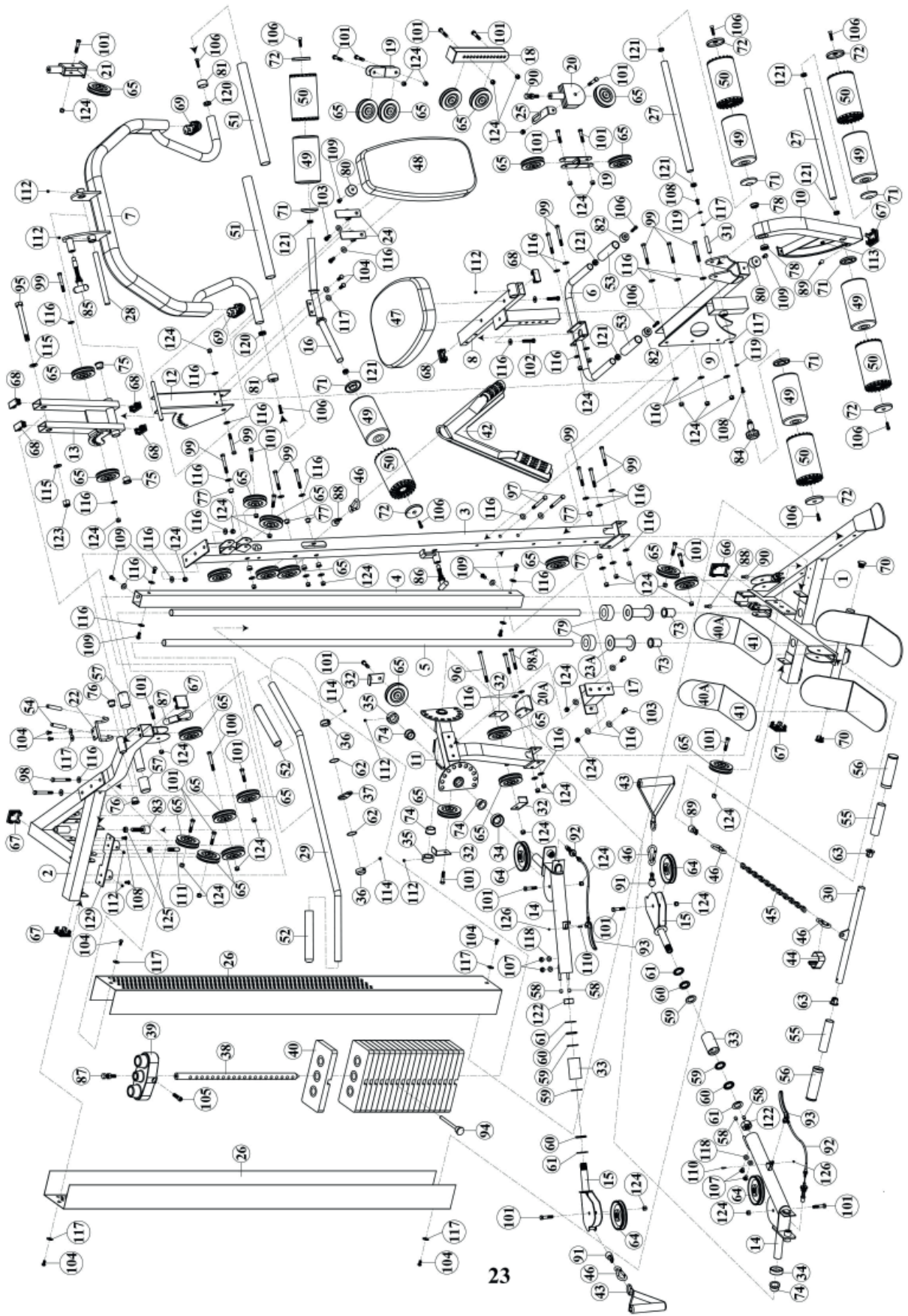

23

7.4 Parts List: Leg Press

No.	Name	Qty.	No.	Name	Qty.
201	BASE STABILIZER	1	223	LEG PRESS BUSHING	2
202	MAIN FRAME	1	224	1/2" X 4-1/4" HEX BOLT	2
203	LEG PRESS SUPPORT	1	225	1/2" X 3-1/4" HEX BOLT	2
204	SEAT HANDLE	1	226	1/2" X 1" HEX THREADED BOLT	4
205	BACK PAD ADJUSTER	1	227	3/8" X 4" HEX BOLT	1
206	FOOT PLATE	1	229	3/8" X 3" HEX BOLT	3
207	RUBBER STOPPER	1	230	3/8" X 1-3/4" HEX BOLT	2
208	φ25mm AXLE	1	231	3/8" X 2-3/4" HEX THREADED BOLT	2
209	φ3/4" AXLE	1			
210	COLLAR	2	232	3/8" X 1" HEX THREADED BOLT	2
211	1-1/4" X 360mm HAND GRIP	2	233	3/8" X 5/8" SET SCREW	1
212	NON SLIP	2	234	5/16" X 1-1/4" INNER HEX SCREW	2
213	BACK PAD	1			
214	SEAT PAD	1	235	1/2" WASHER	11
215	114mm PULLEY	1	236	3/8" WASHER	12
216	90mm PULLEY	3	237	1/2" NYLON NUT	3
217	LEG PRESS CABLE	1	238	3/8" NYLON NUT	6
218	LOCKING SPRING KNOB	1	239	5/16" NUT	2
219	50 X 75mm RECT. PLUG	1	240	SEAT PAD SUPPORT STOPPER	2
220	45mm SQ. PLUG	1	241	CAP FOR NUT	4
221	BEARING	2	242	3/8" X 3-1/2" HEX BOLT	1
222	LEG PRESS STOPPER	1	243	3/4" BUSHING	2

7.5 Exploded Drawing: Leg Press

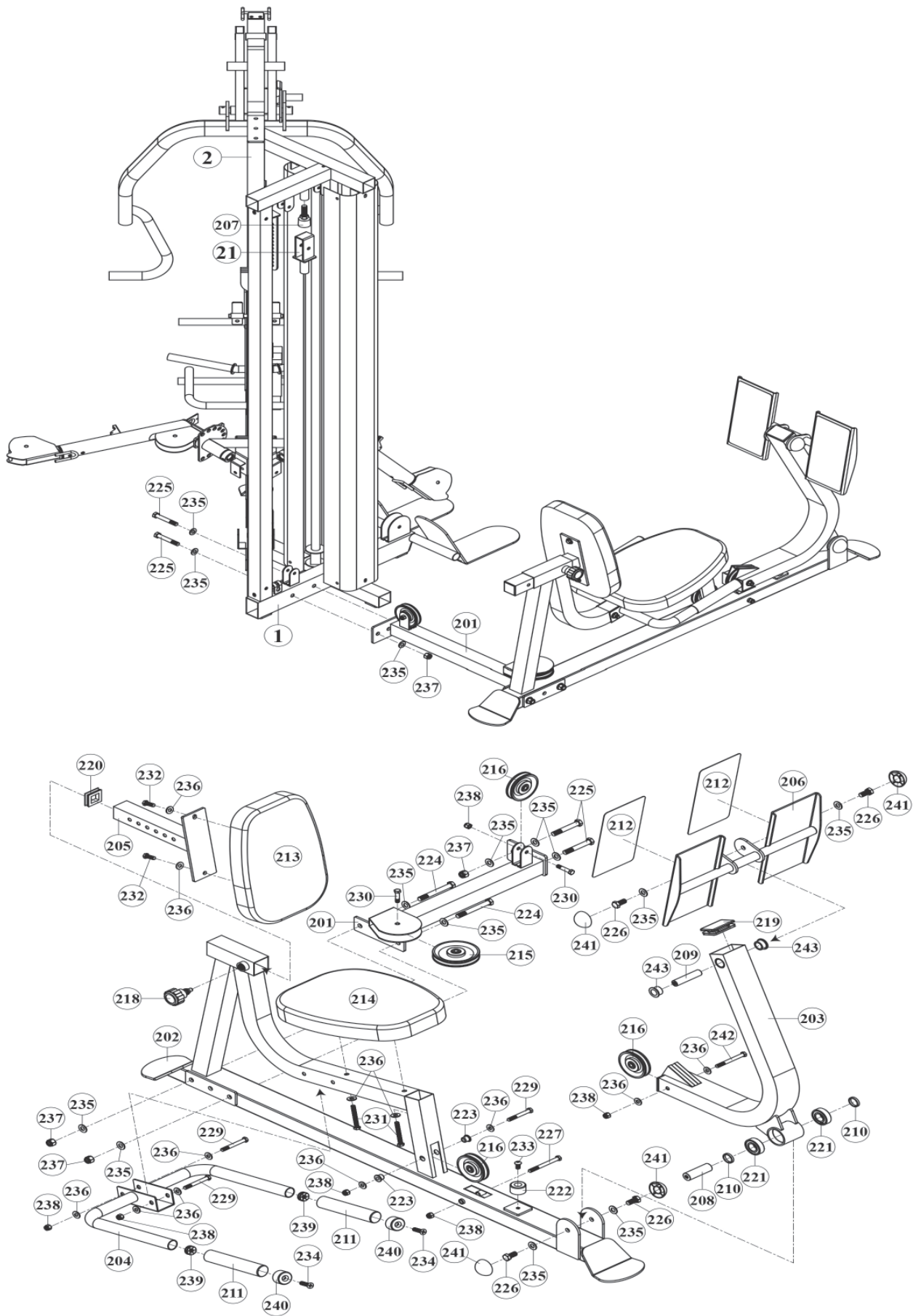

8 WARRANTY

Products from BodyCraft® are subject to strict quality control. However, if a fitness equipment purchased from us does not work perfectly, we take it very seriously and ask you to contact our customer service as indicated. We are happy to help you by phone via our service hotline.

Error Descriptions

Your fitness equipment is developed for long-term, high-quality training. However, should a problem arise, please first read the operating instructions. For further assistance, please contact your contract partner or call our service hotline. To ensure your problem is solved as quickly as possible, please describe the defect as exactly as possible.

In addition to the statutory warranty, we provide a warranty for every fitness equipment purchased from us according to the following provisions.

Your statutory rights are not affected.

Warrantee

The warrantee is the first/original buyer.

Warranty periods

The following warranty periods begin on delivery of the fitness equipment.

Warranty period

The warranty periods, shown on our web shop, begin on delivery of the fitness equipment. The respective warranty periods for your equipment can be found on its product website.

Repair Costs

According to our choice, there will either be a repair, a replacement of individual damaged parts or a complete replacement. Spare parts, that have to be mounted while assembling the equipment, have to be replaced by the warrantee personally and are not a part of repair. After the expiration of the warranty period, the responsibility for parts costs, repair costs, installation costs and delivery costs lies with the warranty holder.

The terms of use are defined as follows:

- + Home use: solely for private use in private households up to 3 hours per day
- + Semi-professional use: up to 6 hours per day (e. g. rehabilitation centres, hotels, clubs, company gyms)
- + Professional use: more than 6 hours per day (e. g. commercial gyms)

Warranty Service

Within the warranty period, equipment which develops faults as a result of material or manufacturing defects, will be repaired or replaced at our discretion. Ownership of equipment or parts of equipment which have been replaced is transferred to us. The warranty period is not extended nor does a new warranty period begin following repair or replacement under the warranty.

Warranty Conditions

For the warranty to be valid, the following steps must be taken:

Please contact our customer service by email or phone. If the product under warranty has to be sent in for repair, the seller bears costs. After expiry of the warranty, the buyer bears the costs of transport and insurance. If the fault is covered by our warranty, you will receive a new or repaired equipment in return.

Warranty claims are invalid in case of damage resulting from:

- + misuse or improper handling
- + environmental influences (moisture, heat, electrical surge, dust, etc.)
- + failure to follow the current safety measures for the equipment
- + failure to follow the operating instructions
- + use of force (e. g. hitting, kicking, falling)
- + interventions which were not carried out by one of our authorized service centres
- + unauthorised repair attempts

Proof of Purchase and Serial Number

Please make sure that you are able to provide the appropriate receipt when claiming on your warranty. So that we can clearly identify the model of your equipment, and for the purposes of our quality control, you will need to give the serial number of your equipment, when contacting the service team. Where possible please have your serial number and your customer number ready when you call our service hotline. It will help us to deal with your request swiftly.







































If you cannot find the serial number on your fitness equipment, our service team is at your disposal to offer further information.

Service outside of the Warranty Period

We are also happy to issue an individual cost estimate if there is a problem with your fitness equipment after the warranty has expired, or in cases which do not fall under the terms of the warranty, e. g. normal wear and tear. Please contact our customer service team to find a quick and cost-effective solution to your problem. In such a case you will be responsible for the delivery costs.

Communication

Many problems can be solved just by speaking to us as your specialist supplier. We know how important it is to you as a user of the fitness equipment to have problems solved quickly and simply, so you can enjoy working out with minimal interruption. For that reason, we also want to resolve your queries quickly and in a straightforward manner. Thus, please always keep your customer number and the serial number of the faulty equipment handy.

DE	DK	UK
<p>TECHNIK</p> <p> +49 4621 4210-900  +49 4621 4210-698  technik@fitshop.de  Öffnungszeiten entnehmen Sie unserer Homepage.</p> <p>SERVICE</p> <p> 0800 20 20277 (kostenlos)  04621 4210 - 0  info@fitshop.de  Öffnungszeiten entnehmen Sie unserer Homepage: https://stg.fit/statita</p>	<p>TEKNIK OG SERVICE</p> <p> 80 90 16 50 +49 4621 4210-945  info@fitshop.dk  Åbningstider kan findes på hjemmesiden: https://stg.fit/statit7</p>	<p>CUSTOMER CARE</p> <p> +44 141 737 2249 or +44 141 876 3972  customercare@fitshop.co.uk  You can find the opening hours on our homepage: https://stg.fit/statitd</p>
	FR	BE
	<p>TECHNIQUE & SERVICE</p> <p> +33 (0) 189 530984 +49 4621 42 10 933  info@fitshop.fr  Vous trouverez les heures d'ouverture sur notre site Internet: https://stg.fit/statit4</p>	<p>TECHNIQUE & SERVICE</p> <p> 02 732 46 77 +49 4621 4210 933  info@fitshop.be  Vous trouverez les heures d'ouverture sur notre site Internet: https://stg.fit/statit8</p>
ES	NL	INT
<p>TECNOLOGÍA Y SERVICIOS</p> <p> 911 238 029  info@fitshop.es  Consulta nuestro horario de apertura en la página web: https://stg.fit/statit5</p>	<p>TECHNISCHE DIENST & SERVICE</p> <p> +31 172 619961  service@fitshop.nl  De openingstijden vindt u op onze homepage: https://stg.fit/statit3</p>	<p>TECHNICAL SUPPORT & SERVICE</p> <p> +49 4621 4210-944  service-int@fitshop.de  You can find the opening hours on our homepage: https://stg.fit/statita</p>
PL	AT	CH
<p>DZIAŁ TECHNICZNY I SERWIS</p> <p> 22 307 43 21 +49 4621 42 10-948  info@fitshop.pl  Godziny otwarcia można znaleźć na stronie głównej: https://stg.fit/statit6</p>	<p>TECHNIK & SERVICE</p> <p> 0800 20 20277 (Freecall) +49 4621 42 10-0  info@fitshop.at  Öffnungszeiten entnehmen Sie unserer Homepage: https://stg.fit/statitb</p>	<p>TECHNIK & SERVICE</p> <p> 0800 202 027 +49 4621 42 10-0  info@fitshop.ch  Öffnungszeiten entnehmen Sie unserer Homepage: https://stg.fit/statit9</p>

Please find a detailed overview including address and opening hours for all stores of Fitshop UK on the following website:

www.fitshop.co.uk/storelocator

WE LIVE FITNESS



WEBSHOP AND SOCIAL MEDIA





The Fitshop Group is Europe's largest specialist for home fitness equipment with currently 70 stores and one of the world's most renowned online mail order companies for fitness equipment.

Fitshop UK is part of the Fitshop Group. Private customers order via the 25 web shops in the respective national language or have their desired equipment assembled on site. In addition, the company supplies fitness studios, hotels, sports clubs, companies and physio practices with professional equipment for endurance and strength training.

The Fitshop group offers a wide range of fitness equipment from renowned manufacturers, high-quality in-house developments and comprehensive services, such as a build-up service and sports scientific advice before and after the purchase. The company employs numerous sports scientists, fitness trainers and competitive athletes.

Visit us also on our social media platforms or our blog!

	https://www.fitshop.co.uk/ www.fitshop.co.uk/blog/
	www.facebook.com/fitshop.co.uk
	www.instagram.com/fitshop_uk
	www.youtube.com/@fitshop_uk

Notes

Notes

Notes

BODYCRAFT