

BODYCRAFT

Assembly Instructions

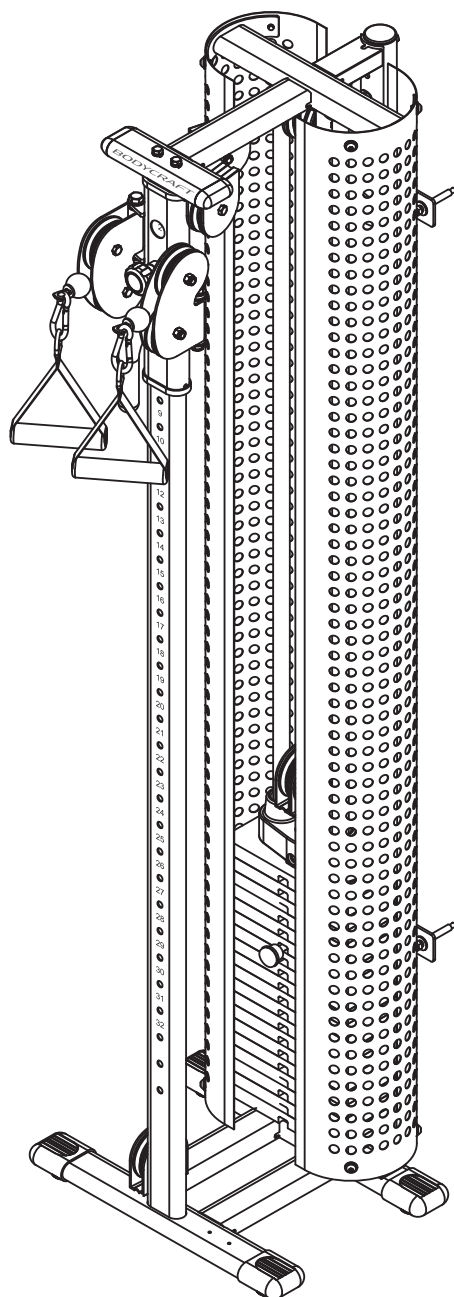

~ 120 Min.



137 kg

L 54 | W 61 | H 203

FSUKSEBR6252.01.01

SKU: SEBR6252

BodyCraft Cable Pull Tower

Content

1	GENERAL INFORMATION	6
1.1	Technical Data	6
1.2	Personal Safety	7
1.3	Set-Up Place	8
2	ASSEMBLY	9
2.1	General Instructions	9
2.2	Scope of Delivery	10
2.3	Assembly	12
2.4	Adjusting the Cable Tension	20
3	STORAGE AND TRANSPORT	21
3.1	General Instructions	21
4	TROUBLESHOOTING, CARE AND MAINTENANCE	21
4.1	General Instructions	21
4.2	Faults and Fault Diagnosis	21
4.3	Maintenance and Inspection Calendar	22
5	DISPOSAL	22
6	RECOMMENDED ACCESSORIES	23
7	ORDERING SPARE PARTS	24
7.1	Serial Number and Model Name	24
7.2	Parts List	25
7.3	Exploded Drawing	26
8	WARRANTY	27
9	CONTACT	29

Dear customer,

Thank you for choosing BodyCraft® training equipment. Bodycraft equipment inspires with its multifunctionality and excellent workmanship and is one of the highest quality fitness equipment for home use in terms of innovation and technology. BodyCraft weight stations, for example, offer a very wide range of exercise possibilities. This ranges from traditional strength training such as bench presses to rehabilitation exercises and workouts for complex sports such as golf, tennis or badminton.

Intended Use

The equipment may only be used for its intended purpose.

The equipment is suitable for home use and semi-professional use (e.g. hospitals, clubs, hotels, schools, etc.). The equipment is not suitable for commercial or professional use (e.g. fitness studio).

Legal Notice

Fitshop GmbH
Europe's No. 1 for home fitness

International Headquarters
Flensburger Straße 55
24837 Schleswig
Germany

Management:
Christian Grau
Sebastian Campmann
Dr. Bernhard Schenkel
No. HRB 1000 SL
Local Court Flensburg
European VAT Number: DE813211547

BODYCRAFT

Disclaimer

BodyCraft® is a registered brand of the company Fitness Authority Industrial Co., LTD. All rights reserved. Any use of this trademark without the explicit written permission of Fitness Authority Industrial Co., LTD is prohibited.

Product and manual are subject to change. Technical data can be changed without advance notice.

ABOUT THIS MANUAL

Please carefully read the entire manual before installation and first use. The manual will help you to quickly set up the system and explains how to safely use it. Make sure that all persons exercising with the equipment (especially children and persons with physical, sensory, mental or motor disabilities) are informed about this manual and its contents in advance. In case of doubt, responsible persons must supervise the use of the equipment.

Due to ongoing changes and software optimisations, the manual may have to be updated. If you notice any discrepancies during assembly or use, please refer to the manual uploaded to the webshop. The latest manual is always available there.



This equipment has been manufactured according to the latest safety knowledge. As far as possible, potential safety hazards which could cause injury have been eliminated. Make sure to carefully follow the instructions and that all parts are securely in place. If required, read through the instructions again to correct any mistakes.

Training devices must be classified according to accuracy and use. Accuracy classes are only applicable to devices that display training data.

Accuracy classes

Class A: high accuracy.

Class B: medium accuracy.

Class C: low accuracy.

The use classes explain the intended use of the training device.

Use classes

Class S (studio): professional and/or commercial use.

These training devices are intended for the use in training rooms of facilities such as sports clubs, school facilities, hotels, clubs and studios whose access and supervision is specifically regulated by the owner (person with legal responsibility).

Class H (home use): use at home.

These stationary training devices are intended for the use in private homes where access to the training device is regulated by the owner (person with legal responsibility).

Please pay close attention to the safety and maintenance instructions given here. The contract partner cannot be held liable for damage to health, accidents or damage to the equipment when it is not used in accordance with these instructions.

The following safety instructions may appear in this manual:

► **ATTENTION**

This notice indicates potentially hazardous situations which, if not avoided, may result in property damage.

⚠ **CAUTION**

This notice indicates potentially hazardous situations which, if not avoided, may result in slight or minor injuries!

⚠ **WARNING**

This notice indicates potentially hazardous situations which, if not avoided, may result in death or serious injuries!

⚠ **DANGER**

This notice indicates potentially hazardous situations which, if not avoided, will result in death or serious injuries!

ⓘ **NOTICE**

This notice indicates further useful information.

Retain these instructions in a safe place for future reference, maintenance or when ordering replacement parts.

1.1 Technical Data

Weight and Dimensions

Packaging dimensions (L x W x H) and weight (gross, incl. packaging) approx.:

Box 1:	78 cm x 53 cm x 18 cm	28.2 kg / 62 lbs
Box 2:	208 cm x 30 cm x 16 cm	28.5 kg / 62 lbs
Box 3:	28 cm x 19 cm x 15 cm	31.27 kg / 69 lbs
Box 4:	27 cm x 14 cm x 13 cm	22.42 kg / 50 lbs

Set-up dimensions (L x W x H) approx.: 54 cm x 61 cm x 203 cm

Article weight (net, excl. packaging) approx.: 136,2 kg / 300 lbs

Weight stack:	90 kg / 200 lbs
Weight plates:	19 + 1 (4.5 kg / 10 lbs each)
Cable length:	982 cm
Cable material:	Steel
Cover material:	Nylon
Transmission ratio:	4 : 1
Pulley diameter:	90 mm

Use class: S

1.2 Personal Safety

DANGER

- + Before you start using the equipment, you should consult your physician that this type of exercise is suitable for you from a health perspective. Particularly affected are persons who: have a hereditary disposition to high blood pressure or heart disease, are over the age of 45, smoke, have high cholesterol values, are overweight and/or have not exercised regularly in the past year. If you are under medical treatment that affects your heart rate, medical advice is absolutely essential.
- + Note that excessive training can seriously endanger your health. Please also note that heart rate monitoring systems can be inaccurate. If you notice any signs of weakness, nausea, dizziness, pain, shortness of breath, or other abnormal symptoms, stop exercising immediately and seek advice from your doctor if necessary.
- + The owner must communicate all warnings and instructions to the user.

WARNING

- + This equipment may not be used by children under the age of 14.
- + Children should not be allowed unsupervised access to the equipment.
- + Persons with disabilities must have a medical license and must be under strict observation when using the equipment.
- + The equipment is strictly for use by one person at a time.
- + Keep your hands, feet and other body parts, hair, clothing, jewellery and other objects well clear of moving parts.
- + During use, wear suitable sports clothing rather than loose or baggy clothing. When wearing sports shoes, make sure they have suitable soles, preferably made of rubber or other non-slip materials. Shoes with heels, leather soles, studs or spikes are unsuitable. Never exercise barefoot.
- + Always start each workout with a light warm-up and end with a cool-down phase.
- + Using the machine as a support during stretching exercises or attaching resistance bands, ropes or other accessories to it, may cause injuries.

CAUTION

- + If your equipment needs to be connected to the power supply with a mains cable, make sure that the cable is not a potential tripping hazard.
- + Make sure that nobody is within the range of motion of the equipment during training so as not to endanger you or other persons.
- + Be aware that if adjustment devices are left protruding, they may impede the user's movement.
- + The weights should remain in the user's field of vision during the entire exercise to prevent danger to third parties.

ATTENTION

- + Do not insert any objects of any kind into the openings of the device.

1.3 Set-Up Place

WARNING

- + Do not place the equipment in main corridors or escape routes.

CAUTION

- + Choose a location in which to place the equipment such that there is enough free space/clearance to the front, the rear and to the sides of the equipment.
- + The training room should be well ventilated during training and not be exposed to any draughts.
- + Choose the place in which to set up the equipment such that there is enough free space/clearance to the front, the rear and to the sides of the equipment.
- + The free area in the direction from which the exercise equipment is accessed must be at least 0.6 m larger than the exercise area.
- + The set-up and mounting surface of the equipment should be flat, loadable and solid.
- + If your device is to be mounted on the wall/ceiling, make sure that you use the appropriate assembly material to avoid possible damages or personal injuries. The contractual partner accepts no liability for this.

ATTENTION

- + The device may only be used in one building, in sufficiently tempered and dry rooms (ambient temperatures between 10°C and 35°C). The equipment should not be used outdoors or in rooms with high humidity (over 70%) like swimming pools.
- + A floor protective mat/equipment underlay can help to protect high-quality floor coverings (parquet, laminate, cork, carpets) from dents and sweat and can help to level out slight unevenness.
- + For Class S equipment, the exercise equipment may only be used in areas where access, supervision and control are specifically regulated by the owner.

2.1 General Instructions



DANGER

- + Do not leave any tools, packaging materials such as foils or small parts lying around, as otherwise there is a danger of suffocation for children. Keep children away from the equipment during assembly.



WARNING

- + Pay attention to the instructions attached to the equipment in order to reduce the risk of injuries.



CAUTION

- + Ensure to have sufficient room for movement in each direction during assembly.
- + The assembly of the equipment must be carried out by at least two adults. If in doubt, seek the help of a third technically skilled person.



ATTENTION

- + To prevent damage to the equipment and the floor, assemble the equipment on a mat or packaging board.



NOTICE

- + In order to make the assembly as simple as possible, some screws and nuts to be used can already be pre-assembled.
- + Ideally, assemble the equipment at its later set-up place.

2.2 Scope of Delivery

The scope of delivery consist of the following parts. At the beginning, check whether all parts and tools belonging to the device are included in the scope of delivery and whether damage has occurred. In the event of complaints, the contractual partner must be contacted directly.

⚠ CAUTION

If parts of the scope of delivery are missing or damaged, the assembly must not be carried out.

Required tools: Ratchet, 9/16" Socket, 3/4" Socket, 9/16" Combination Wrench, 3/4" Combination Wrench, Adjustable Wrench, Rubber Mallet, Metric Allen Key Set

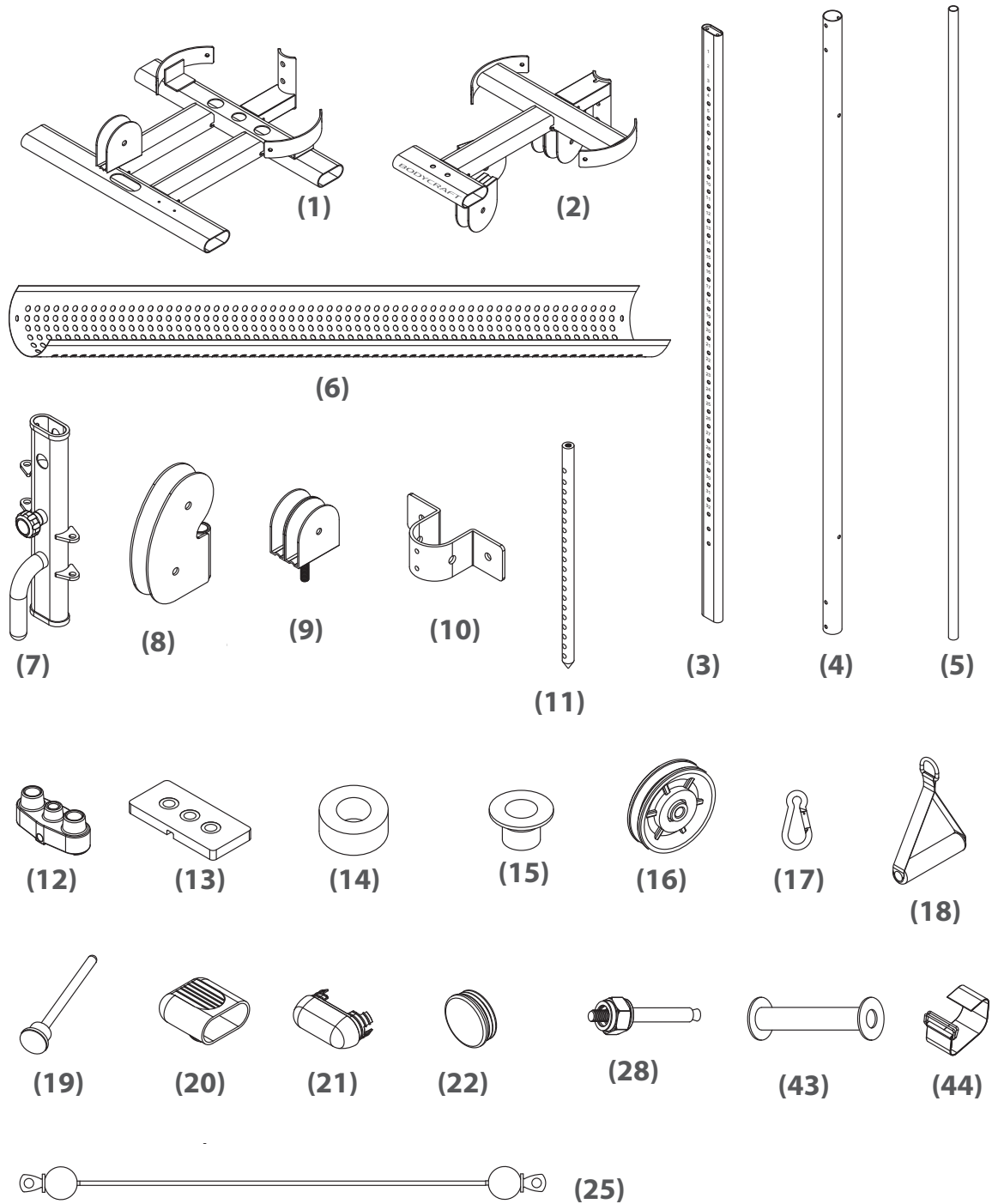

No.	Name	No.	Name
1	Base Frame	14	Rubber Donut
2	Top Frame	15	Plastic Guide Rod Holder
3	Front Upright Frame	16	Pulley
4	Rear Upright Frame	17	Clip
5	Guide Rod	18	Single Handle
6	Weight Shroud	19	Selector Pin
7	Cable Height Adjuster	20	Oval End Cap
8	Swivel Pulley Housing	21	Oval Cap
9	Double Pulley Bracket	22	Round Cap
10	Bracket Frame	25	Cable
11	Selector Rod	28	5/16" X 2 Hand Set
12	Top Plate	43	Stack Spacer
13	Weight Plate	44	Ankle Strap

Screw-Kit

No.	Name	Qty.
29	1/2" X 4-1/4" Hex Bolt	2
30	3/8" X 3" Hex Bolt	4
31	3/8" X 2-3/4" Hex Bolt	4
32	3/8" X 1-3/4" Hex Bolt	7
33	3/8" X 1" Hex Threaded Bolt	4
35	Top Plate Bolt	1
36	1/2" Washer	4
37	3/8" Spring Washer	4
39	3/8" Washer	10
40	1/2" Nylon Nut	2
41	3/8" Nylon Nut	13

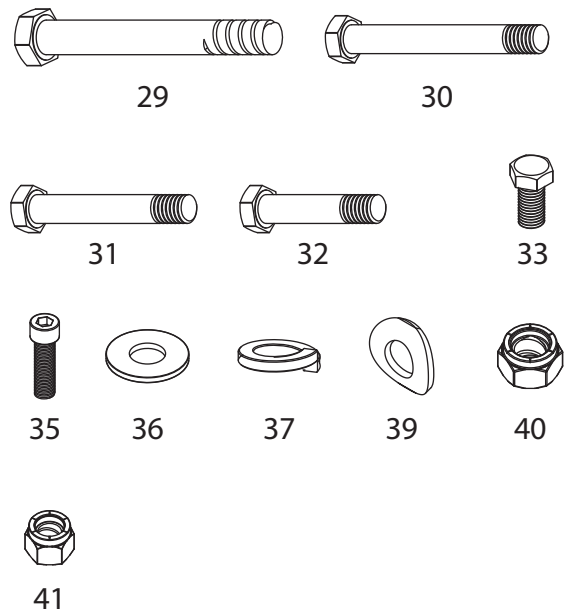

2.3 Assembly

Before assembly, take a close look at the individual assembly steps shown and carry out the assembly in the order given.

NOTICE

- + First loosely screw all parts together and check that they fit properly. Tighten the screws using the tool only when you are instructed to do so.
- + If you have difficulty recognising the graphics, we recommend that you open and/or download the PDF instructions stored in the webshop on your end device (e.g. smartphone, tablet or PC). There you have the option of zooming in closer. Please note that the Adobe Acrobat Reader programme must be installed on your end device in order to open the file.

Step 1: Assembly of Base Frame

1. Attach four oval end caps (20) to the base frame (1). Attach two round caps (22) to the rear upright frame (4).
2. Attach two bracket frames (10) to the rear upright frame (4) using two 3/8" X 3" hex bolts (30), four 3/8" washers (39) and two 3/8" nylon nuts (41).
3. Attach the base frame (1) to the rear upright frame (4) using two 3/8" X 2-3/4" hex bolts (31), three 3/8" semicircle washers (39) and one 3/8" nylon nut (41).
4. Tighten the bolts.

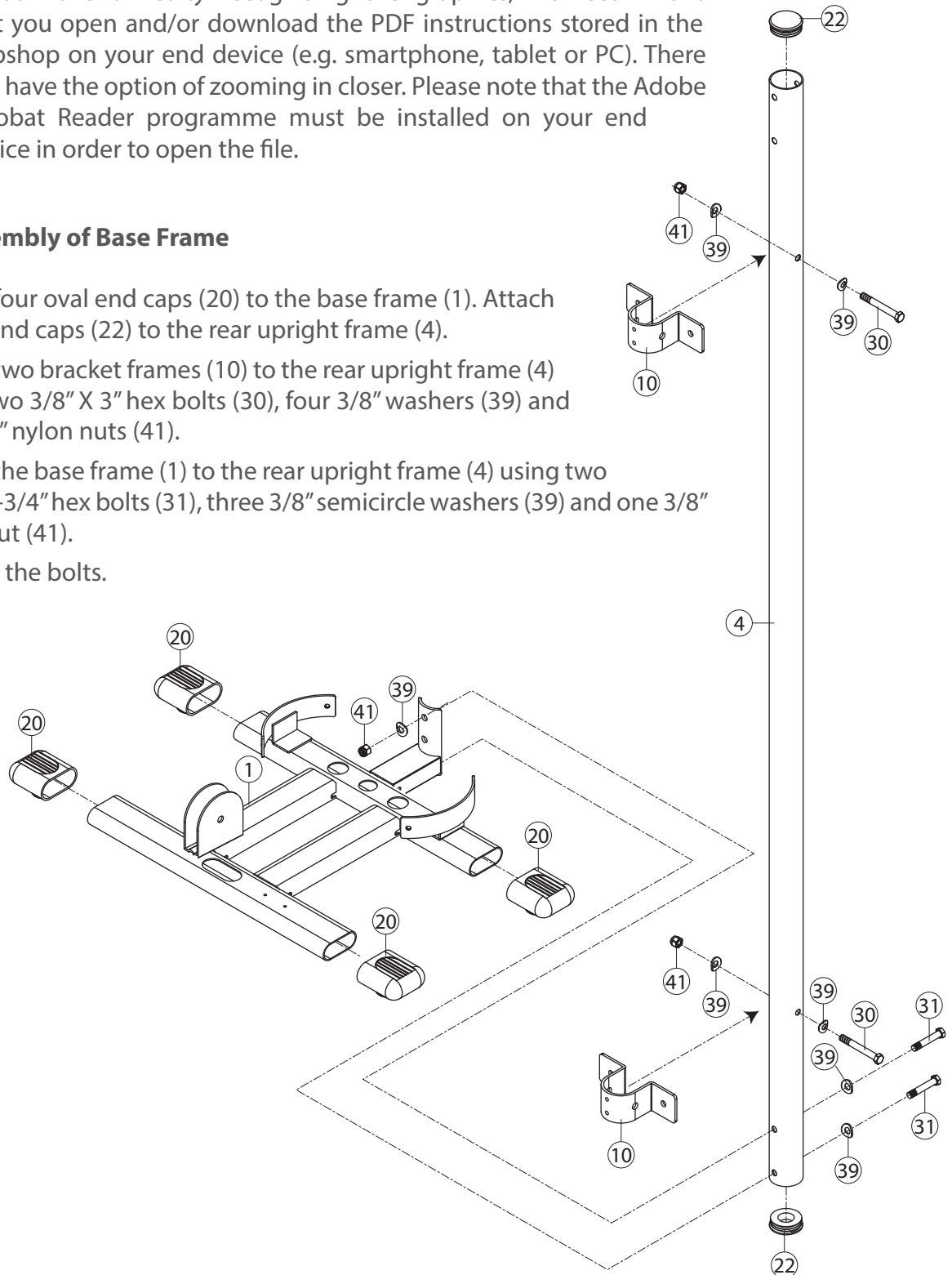

Step 2: Preparation for Wall Mounting

► ATTENTION

The supplied assembly material for wall mounting is not suitable for every wall. Pay attention to the condition of your wall to determine which assembly material is suitable for your wall.

The contractual partner accepts no liability for any damage to the wall.

Make sure that there are no cables or wires running in the wall where you attach the training equipment.

ⓘ NOTICE

The supplied assembly material is not suitable for every wall, so you may need to get assembly material that is suitable for your wall.

ⓘ NOTICE

A hand drill is required for this assembly step. Make sure that you use a suitable drilling attachment.

1. Place the cable pulling station at the desired position and mark the drill holes.
2. Remove the cable pulling station from the wall and drill the required holes in the wall with a hand drill.

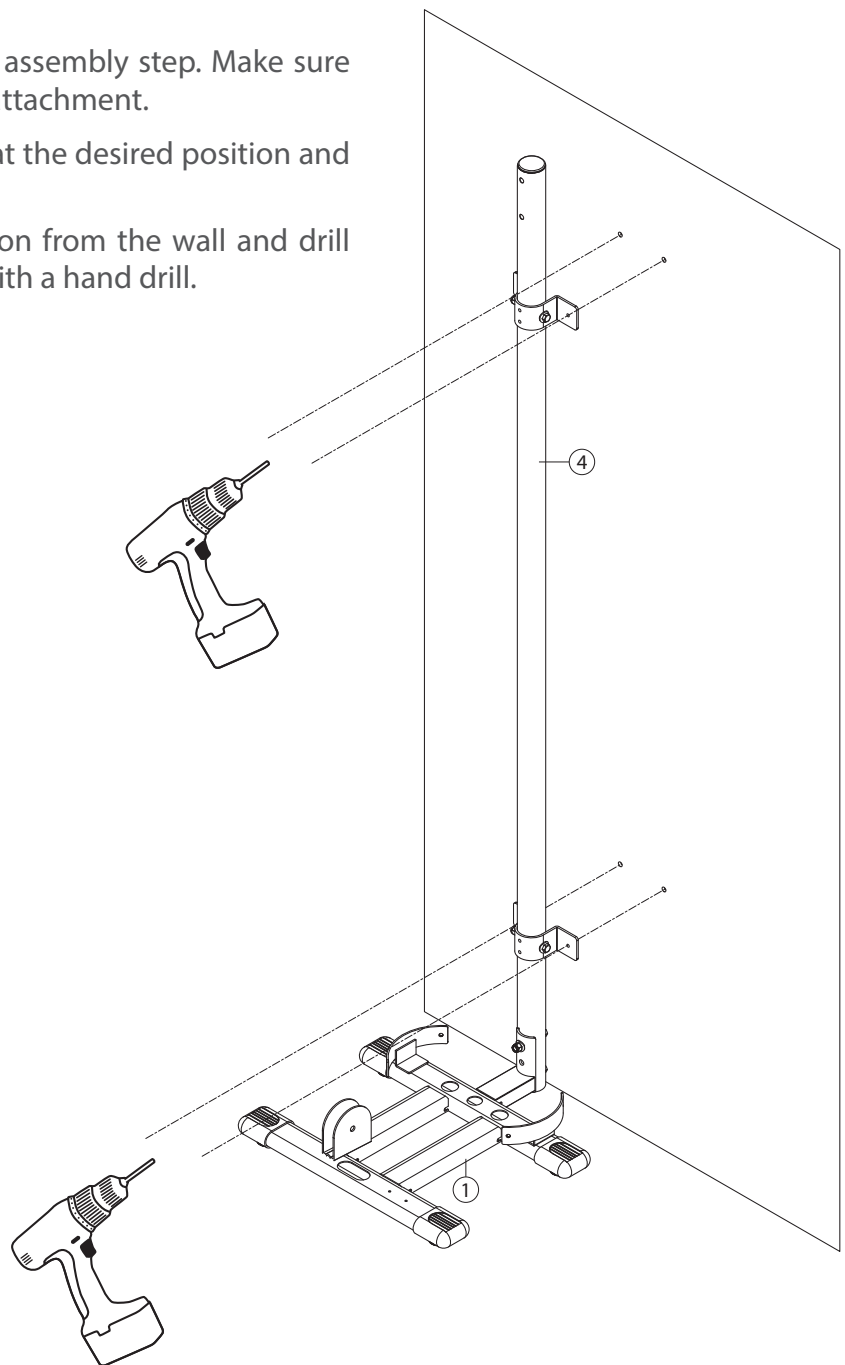

Step 3: Assembly of Weight Stack

1. Attach the front upright frame (3) to the base frame (1) using two 3/8" X 1" hex threaded bolts (33) and two 3/8" spring washers (37).
2. Attach two swivel pulley housings (8) to the cable height adjuster (7) using two 1/2" X 4-1/4" hex bolts (29), four 1/2" washers (36), and two 1/2" nylon nuts (40).
3. Slide the cable height adjuster (7) over the top of the rear upright frame (3). Stop at your desired height by locking the knob (26).

► **ATTENTION**

If you have 19 weight plates, DO NOT install the two spacers (43).

ⓘ **NOTICE**

The whole weight stack consists of the 14 or 19 weight plates with part number 13 and the upper plate with part number 12. This results in a total of 15 or 20 weight plates.

4. Slide two stack spacers (43) and two rubber donuts (14) onto one end of each guide rod (5) and then insert the guide rods (5) into the plastic guide rod holders (15) in the base frame (1) as shown.
5. Slide each weight plate (13) over the guide rods (5). Make sure that each plate is oriented with selector hole on the bottom and facing forward.
6. Screw the double pulley bracket (9) into the top plate (12) with the selector rod (11).

► **ATTENTION**

The thread of the double pulley bracket (9) must be screwed into the top plate (12) at least 2 cm.

7. Attach the top plate (12) to the selector rod (11) using the top plate bolt (35). Slide the top plate (12) and the selector rod (11) over the guide rods (5).
8. Insert the selector pin (19) into one of the slots on the weight stack.
9. Tighten the bolts.

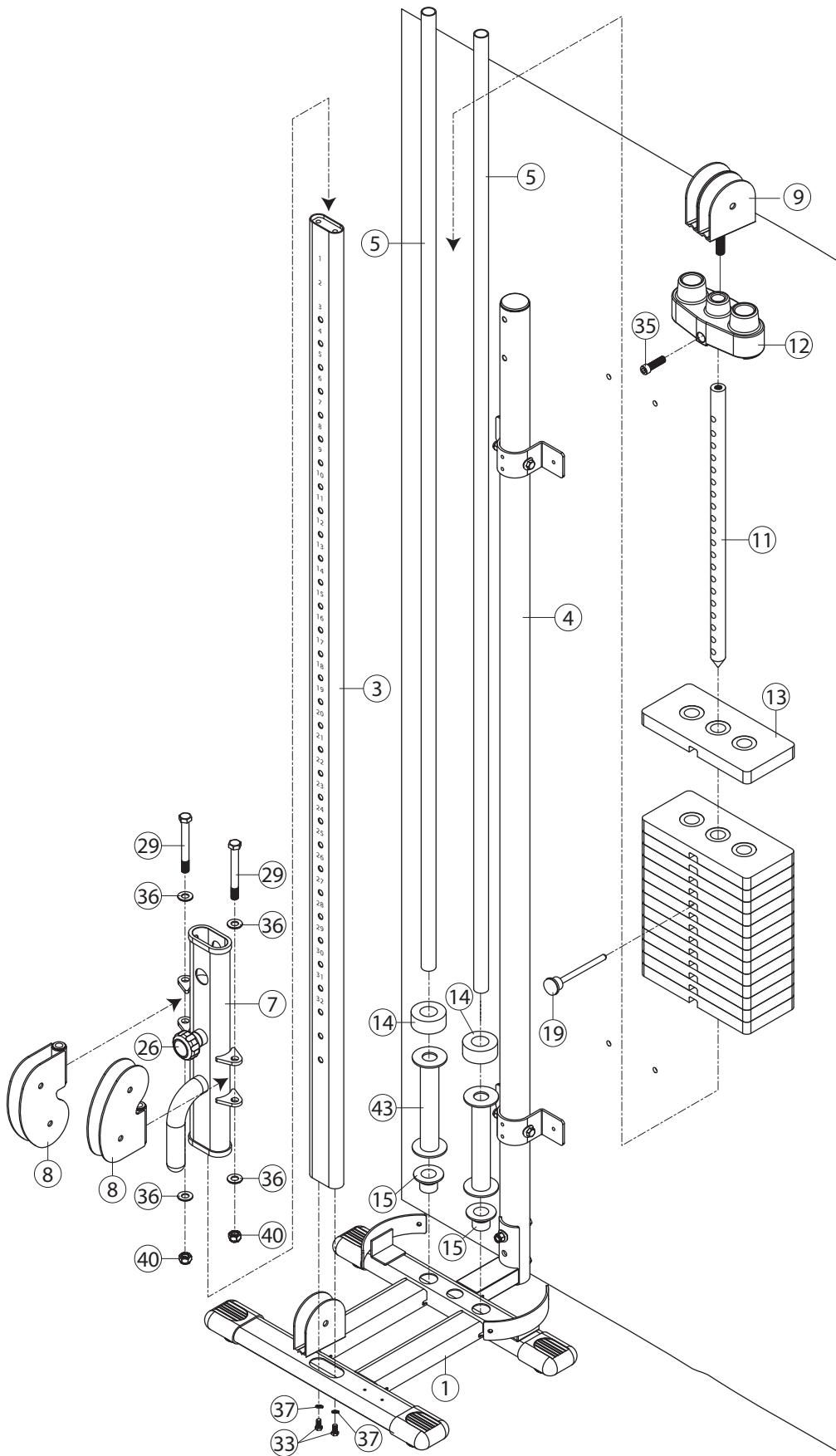

Step 4: Assembly of Top Frame and Wall Mounting

NOTICE

If the wall has areas of unevenness, such as a skirting board, the screws (28) supplied are not suitable for wall mounting. In such a case, you need to purchase a suitable mounting set of screws yourself.

1. Attach two oval caps (21) to the top frame (2). Attach the top frame (2) to the front upright frame (3) using two 3/8" X 1" hex threaded bolts (33) and two 3/8" spring washers (37).
2. Insert the plastic guide rod holders (15) into the top frame (2).
3. Attach the top frame (2) to the rear upright frame (4) using two 3/8" X 2-3/4" hex bolts (31), three 3/8" semicircle washers (39), and one 3/8" nylon nut (41).
4. Use four 5/16" X 2" hand sets (28) to fix onto the wall.

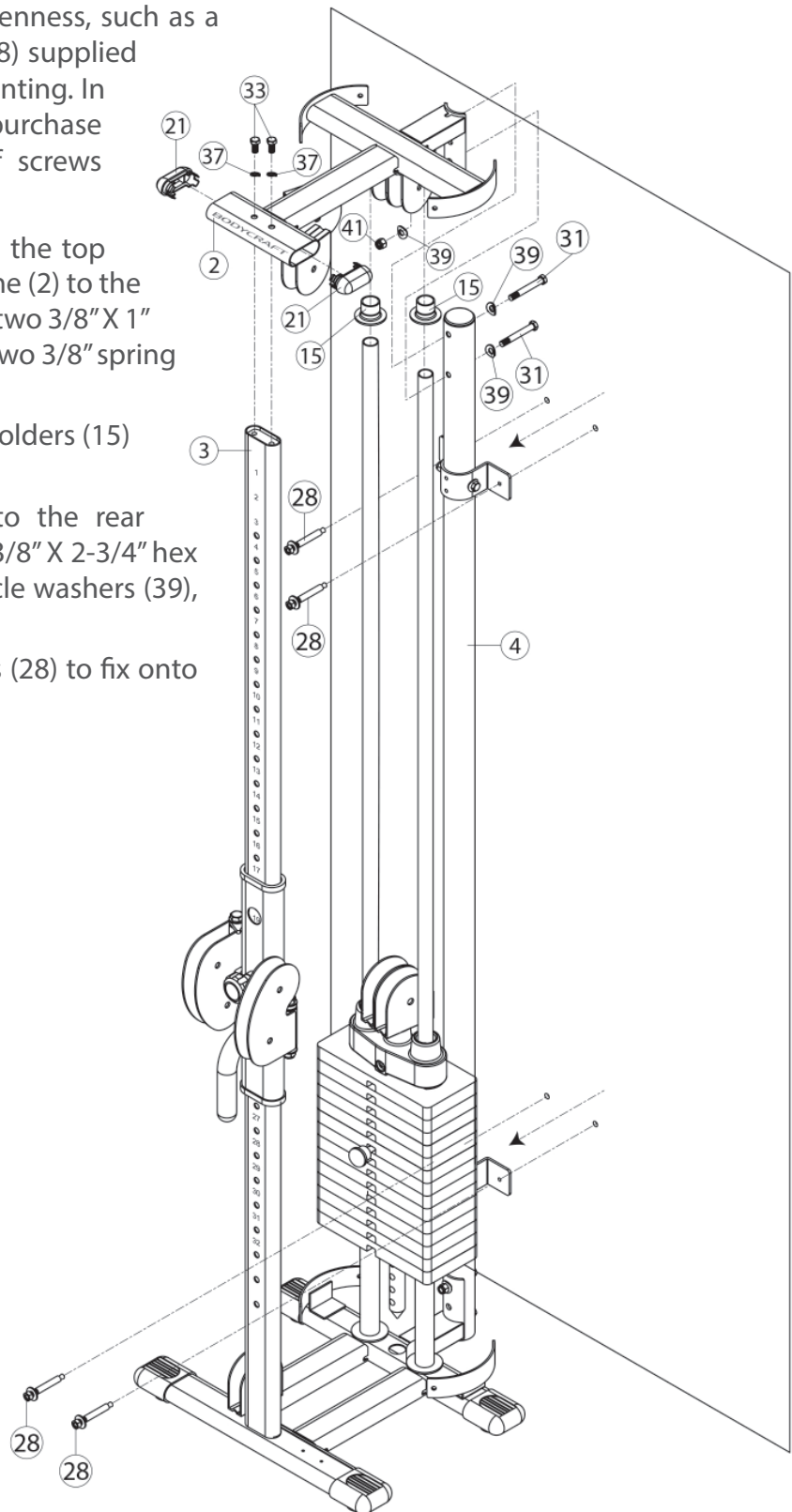

Step 5: Assembly of Cable

1. Insert one end of the cable (25) into the front right side of the swivel pulley housing (8) and pull it out upwards. Mount two pulleys with two 3/8" X 1-3/4" hex bolts (32) and two 3/8" nylon nuts (41), see C1 and C9.
2. Run the cable to the top frame (2) over pulley C2 and C3. Mount pulley C2 with a 3/8" X 1-3/4" hex bolt (32) and a 3/8" nylon nut (41) and temporarily mount pulley C3 with a 3/8" X 3" hex bolt (30) and one 3/8" nylon nut (41), see C2, C3, C5 and C7.
3. Run the cable down to the right-hand bracket of the double pulley bracket (9) and around pulley C4 (Fig. 1). Temporarily mount pulley C4 with 3/8" X 2-3/4" hex bolt (31) and one 3/8" nylon nut (41).
4. Run the cable to the top frame (2) over pulley C5. Loosen the previously mounted 3/8" X 2-3/4" hex bolt (31) and 3/8" nylon nut (41). Mount the pulleys C5 and C3 with the loosened bolt and nut.
5. Run the cable down and from behind around pulley C6. Loosen the previously mounted 3/8" X 3" hex bolt (30) and 3/8" nylon nut (41). Mount the Pulleys C6 and C4 with the loosened bolt and nut.
6. Run the cable to the top frame (2) and around pulley C7. Mount the pulley C7 with one 3/8" X 1-3/4" hex bolt (32) and one 3/8" nylon nut (41).
7. Run the cable down and around pulley C8. Mount the pulley C8 with one 3/8" X 1-3/4" hex bolt (32) and one 3/8" nylon nut (41).

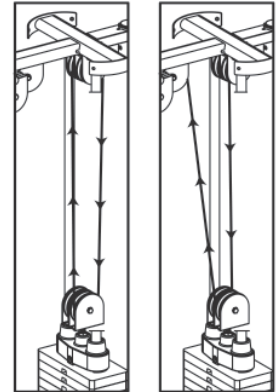
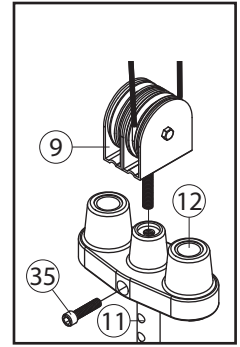
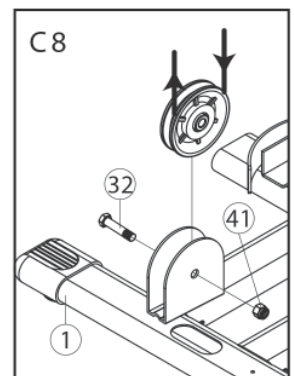
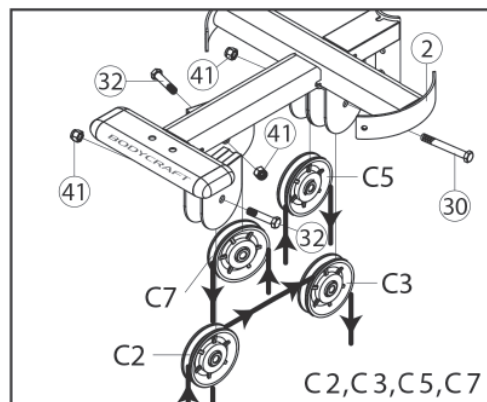
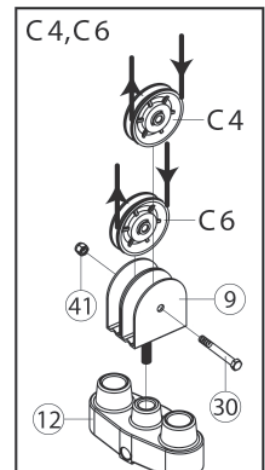
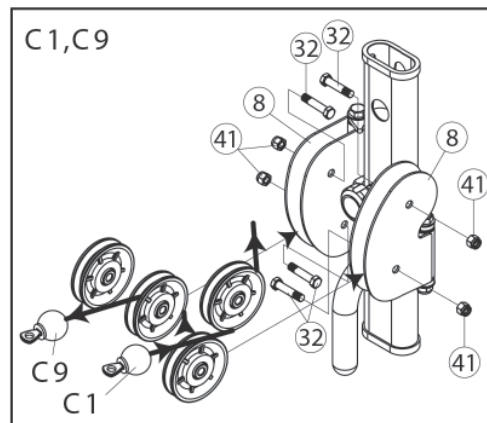

Fig. 1

Fig. 2



(25) CABLE

8. Run the cable from there upwards and from below into the swivel pulley housing (8). Mount two pulleys with two 3/8" X 1-3/4" hex bolts (32) and two 3/8" nylon nuts (41), siehe C1 und C9.
9. Tighten the bolts.

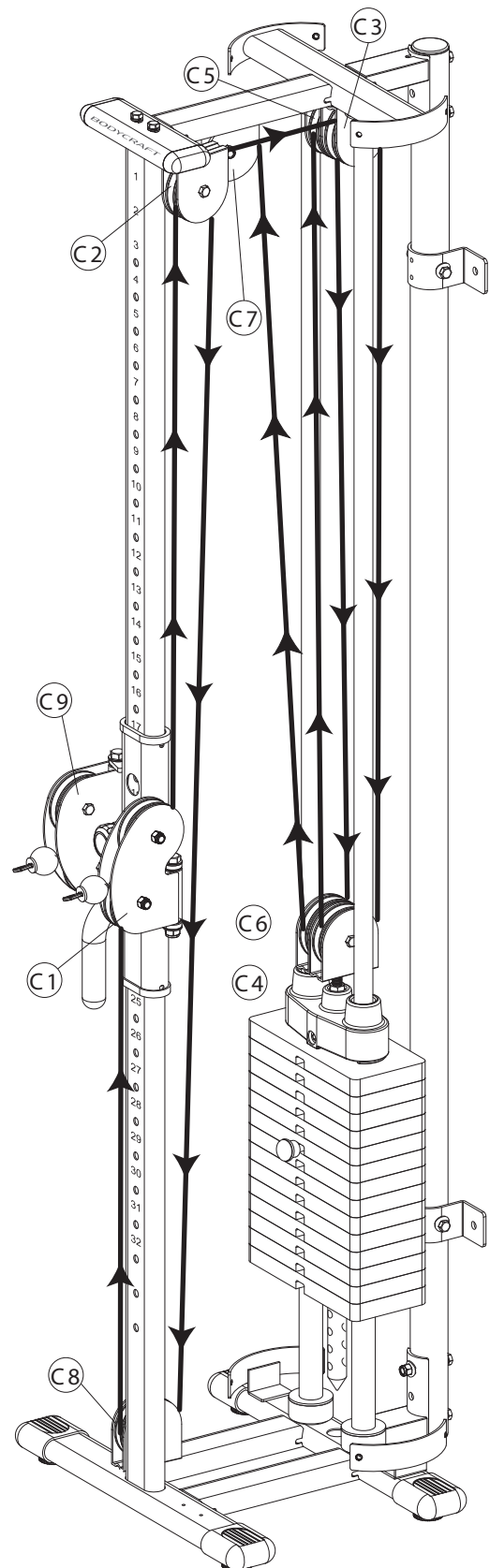

Step 6: Assembly of Weight Shroud

1. Attach the weight shrouds (6) to the top frame (2) and base frame (1) using eight 5/16" washers (38) and eight 5/16" X 1/2" screws (34). Remember to keep all bolts loose in frame to ensure holes line up easily.
2. Tighten all bolts.

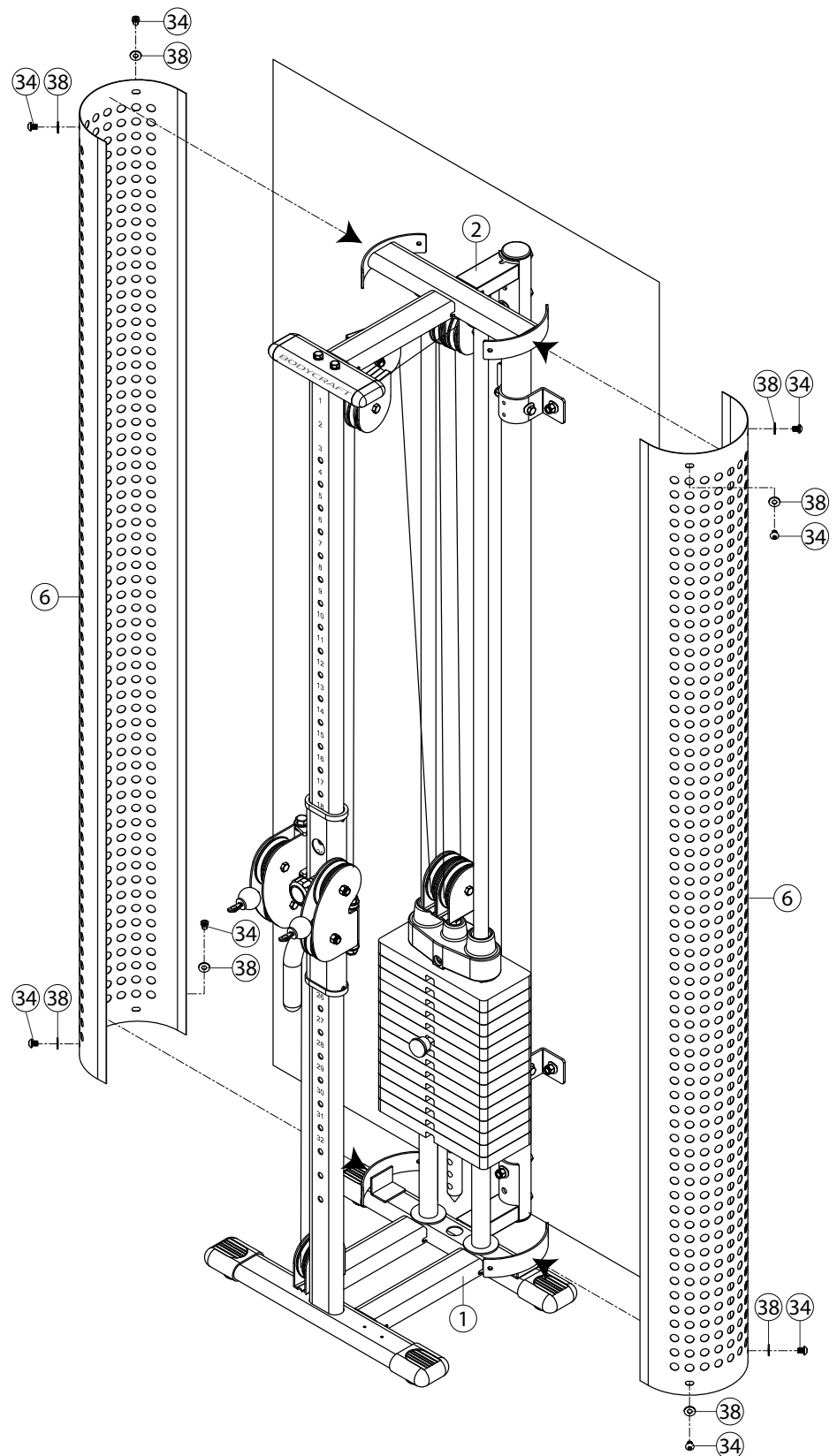

2.4 Adjusting the Cable Tension

The cables should be tensioned so that the top weight plate is just resting on the other weight plates. As soon as the top weight plate does not rest on the other weight plates, the cable should be extended. As soon as the cable slackens, the cable must be shortened.

1. Remove the selector pin (19) from the weight stack.
2. Pull the top plate (12) upwards and secure the selector rod (11) with the selector pin (19), see fig. 1.
3. Remove the top plate bolt (35) from the top plate (12) so that the top plate (12) is no longer connected to the selector rod (11), see fig. 1.
4. Remove the selector pin (19) from the selector rod (11) and lower the top plate (12) back onto the weight stack, see fig. 2.
5. Pull the double pulley bracket (9) along with the selector rod (11) out of the weight stack, see fig. 2.
6. To shorten the cable, turn the selector rod (11) clockwise.
7. To lengthen the cable, turn the selector rod (11) counterclockwise.
8. Check the cable length by lowering the selector rod (11) and inserting the selector pin (19).

► **ATTENTION**

Make sure that the selector holes on the selector rod (11) are back in the correct position in the weight stack.

9. Once you have reached the correct cable tension, fix the top plate (12) again with the top plate bolt (35), see fig. 3.
10. Secure the adjustment by tightening the lock nut on the double pulley bracket (9), see fig. 4.

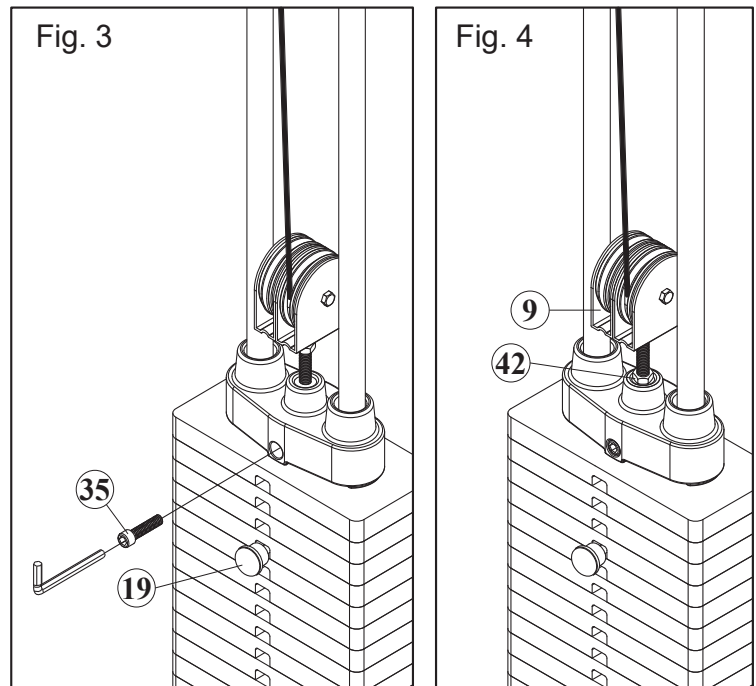
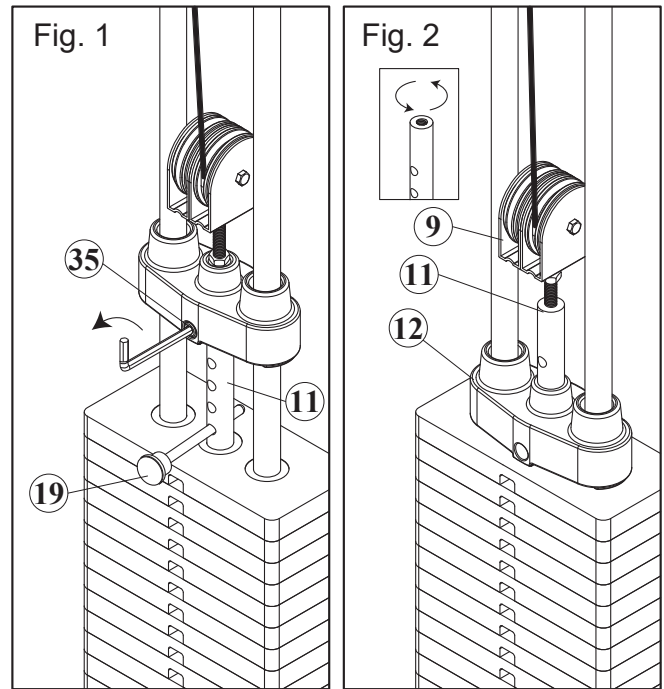

3.1 General Instructions



WARNING

- + The storage location should be chosen so that improper use by third parties or children can be prevented.
- + If your equipment does not have transportation wheels, the equipment must be disassembled before transportation.



ATTENTION

- + Make sure that the equipment is protected from moisture, dust and dirt in the selected storage location. The storage location should be dry and well ventilated and have a constant ambient temperature between 10°C and 35°C.

4.1 General Instructions



WARNING

- + Do not make any improper changes to the equipment.



CAUTION

- + Damaged or worn components may affect your safety and the life of the equipment. Therefore, immediately replace damaged or worn components. In such a case, contact the contract partner. The equipment must not be used until it has been repaired. If necessary, use only original spare parts.



ATTENTION

- + In addition to the instructions and recommendations for maintenance and care given here, additional service and/or repair work may be necessary; this must only be carried out by authorised service technicians.

4.2 Faults and Fault Diagnosis

The equipment undergoes regular quality controls during production. Nevertheless, faults or malfunctions may occur. Frequently, individual parts are responsible for these disturbances, an exchange is usually sufficient. Please refer to the following overview for the most common errors and how to correct them. If the equipment still does not function properly, contact your contract partner.

Fault	Cause	Solution
Grinding noises	Cables or pulleys do not run smoothly or are damaged	<ul style="list-style-type: none">+ Visual inspection of the cable routing or the pulley guide+ If damaged, replace the defective part

Weight hanging in the air	Cable tensioned too tight	Readjust cable tension
Cable without tension	Cable too loose	+ Check cable routing + Readjust cable tension
Squeaking & cracking noises	Screw connections loosened or too tight	+ Check or lubricate screw connections* + Check cable routing
Unit wobbles	+ Uneven ground + Loose screw connections	+ Align unit + Tighten screw connections
Heavy draught	+ Weight holders/guide rods too dry + Faulty cable routing	+ Lubricate guide rods* + Check cable routing

* With a grease-free silicone oil or silicone spray.

4.3 Maintenance and Inspection Calendar

To avoid damage from body sweat, the equipment must be cleaned with a damp towel (no solvents!) after each training session.

The following routine tasks must be performed at the specified intervals:

Part	Weekly	Monthly	Quarterly
Cables	C	I	
Screw connections		I	
Pulleys and cable routing		I	
Slide rails/Guide rods		I	
Weights			I
Legend: C = clean; I = inspect			

5 DISPOSAL

At the end of its operational life, this equipment cannot be disposed of in normal household waste. Instead, it must be disposed of via an recycling centre. Further information can be obtained from your local authority's recycling service.

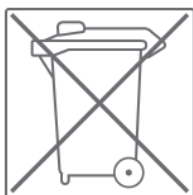

The materials can be recycled as per their symbols. Through the reuse, recycling of materials or other forms of recovery of old equipment, you make an important contribution to the protection of the environment.

6 RECOMMENDED ACCESSORIES

To make your training experience even more efficient and pleasant, we recommend that you add suiting accessories to your fitness equipment. For training equipment like smith machines, weight benches or racks this could for example be a **floor mat**, which makes your fitness equipment stand more securely and also protects the floor from sweat but it could be also **additional weights, handles, foot straps** for leg exercises or **triceps ropes**. For some smith machines, there are also optional add-ons such as **leg presses** that make your workout even more intense and comprehensive.

Our range of accessories offers the highest quality and makes training even better. If you would like to find out more about compatible accessories, please go to the detail page of the product in our webshop (the easiest way is to enter the article number in the search field above) and go to the recommended accessories on this page. Alternatively, you can use the QR code provided. Of course, you can also contact our customer service: by telephone, e-mail, in one of our branches or via our social media channels. We will be happy to advise you!



floor mat



chest strap



tricep and curl bar



triceps rope

7.1 Serial Number and Model Name

In order to provide you with the best possible service, please have the model name, article number, serial number, exploded drawing and parts list ready. The corresponding contact options can be found in chapter 9 of this operating manual.

NOTICE

The serial number of your equipment is unique. It's located on a white sticker. The exact position of this sticker is shown in the following illustration.

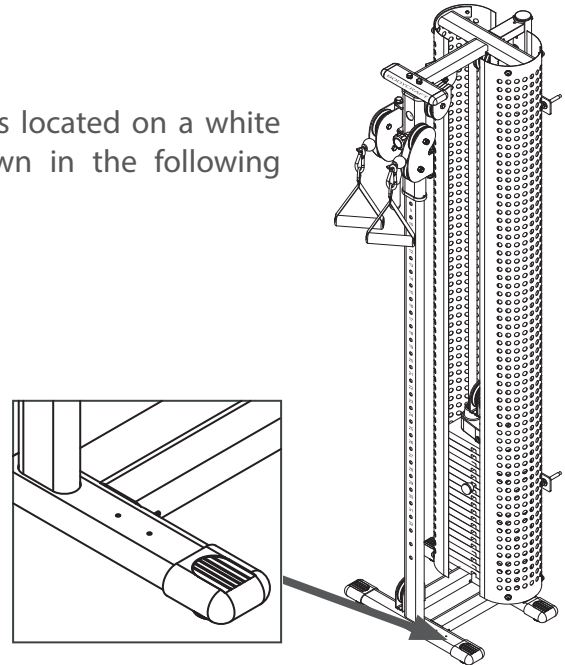

Enter the serial number in the appropriate field.

Serial number:

Brand / Category:

Model Name:

SKU:

7.2 Parts List

No.	Name	Qty.	No.	Name	Qty.
1	BASE FRAME	1	23	HOLLOW	2
2	TOP FRAME	1	24	HANDLE GRIP	1
3	FRONT UPRIGHT FRAME	1	25	CABLE	1
4	REAR UPRIGHT FRAME	1	26	KNOB	1
5	GUIDE ROD	2	27	BUSHING	4
6	WEIGHT SHROUD	2	28	5/16" X 2" HAND SET (For Wall)	4
7	CABLE HEIGHT ADJUSTER	1	29	1/2" X 4-1/4" HEX BOLT	2
8	SWIVEL PULLEY HOUSING	2	30	3/8" X 3" HEX BOLT	4
9	DOUBLE PULLEY BRACKET	1	31	3/8" X 2-3/4" HEX BOLT	4
10	BRACKET FRAME	2	32	3/8" X 1-3/4" HEX BOLT	7
11	SELECTOR ROD	1	33	3/8" X 1" HEX THREADED BOLT	4
12	TOP PLATE	1	34	5/16 X 1/2" SCREW	8
13	WEIGHT PLATE	14	35	TOP PLATE BOLT	1
14	RUBBER DONUT	2	36	1/2" WASHER	4
15	PLASIC GUIDE ROD HOLDER	4	37	3/8" SPRING WASHER	4
16	PULLEY	11	38	5/16" WASHER	8
17	CLIP	2	39	3/8" SEMICIRCLE WASHER	10
18	SINGLE HANDLE	2	40	1/2" NYLON NUT	2
19	SELECTOR PIN	1	41	3/8" NYLON NUT	13
20	OVAL END CAP	4	42	1/2" NUT	1
21	OVAL CAP	2	43	STACK SPACER	2
22	ROUND CAP	2	44	ANKLE STRAP	1

7.3 Exploded Drawing

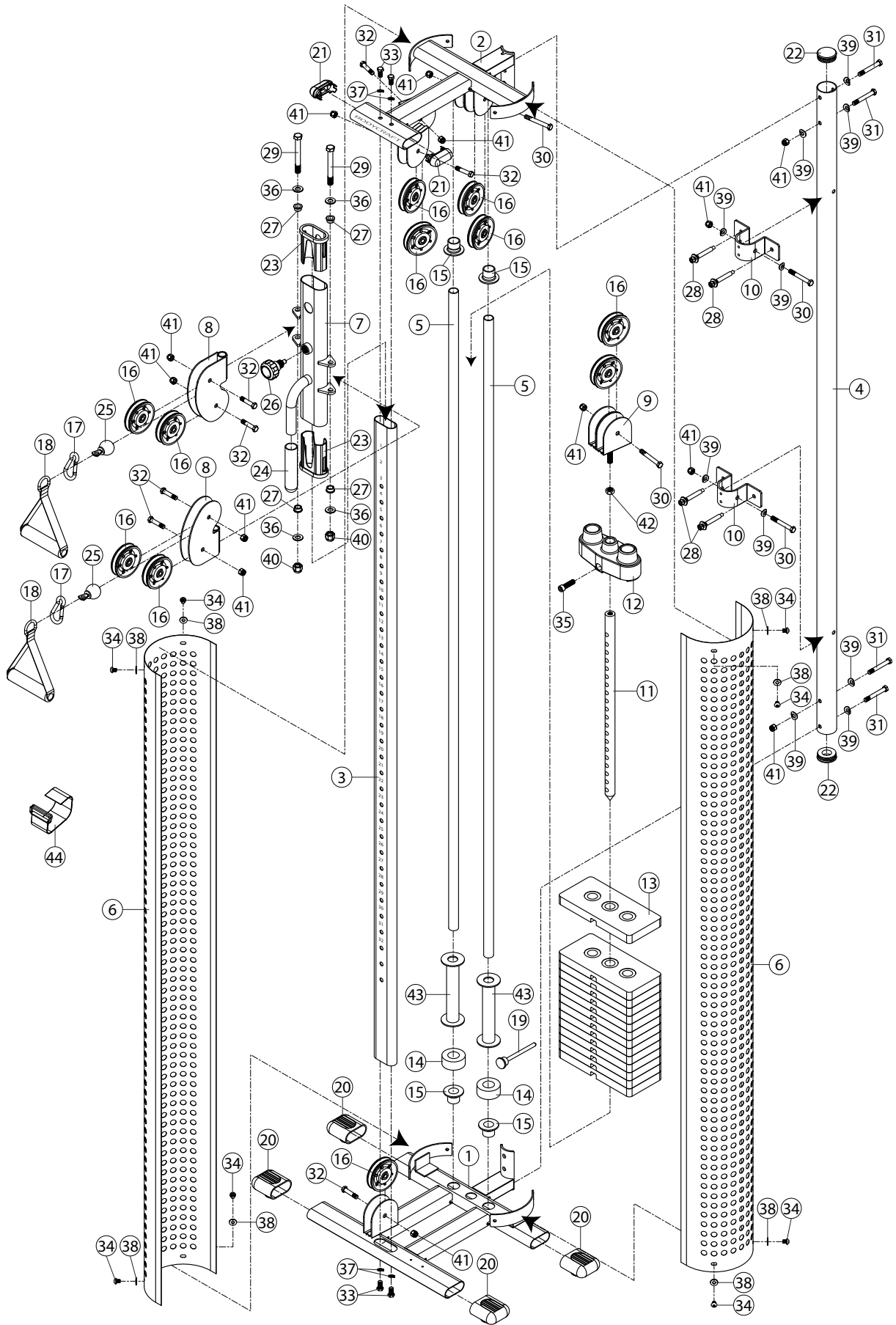

8 WARRANTY

Products from BodyCraft® are subject to strict quality control. However, if a fitness equipment purchased from us does not work perfectly, we take it very seriously and ask you to contact our customer service as indicated. We are happy to help you by phone via our service hotline.

Error Descriptions

Your fitness equipment is developed for long-term, high-quality training. However, should a problem arise, please first read the operating instructions. For further assistance, please contact your contract partner or call our service hotline. To ensure your problem is solved as quickly as possible, please describe the defect as exactly as possible.

In addition to the statutory warranty, we provide a warranty for every fitness equipment purchased from us according to the following provisions.

Your statutory rights are not affected.

Warranty

The warranty is the first/original buyer.

Warranty periods

The following warranty periods begin on delivery of the fitness equipment.

Warranty period

The warranty periods, shown on our web shop, begin on delivery of the fitness equipment. The respective warranty periods for your equipment can be found on its product website.

Repair Costs

According to our choice, there will either be a repair, a replacement of individual damaged parts or a complete replacement. Spare parts, that have to be mounted while assembling the equipment, have to be replaced by the warranty holder personally and are not a part of repair. After the expiration of the warranty period, the responsibility for parts costs, repair costs, installation costs and delivery costs lies with the warranty holder.

The terms of use are defined as follows:

- + Home use: solely for private use in private households up to 3 hours per day
- + Semi-professional use: up to 6 hours per day (e. g. rehabilitation centres, hotels, clubs, company gyms)
- + Professional use: more than 6 hours per day (e. g. commercial gyms)

Warranty Service

Within the warranty period, equipment which develops faults as a result of material or manufacturing defects, will be repaired or replaced at our discretion. Ownership of equipment or parts of equipment which have been replaced is transferred to us. The warranty period is not extended nor does a new warranty period begin following repair or replacement under the warranty.

Warranty Conditions

For the warranty to be valid, the following steps must be taken:

Please contact our customer service by email or phone. If the product under warranty has to be sent in for repair, the seller bears costs. After expiry of the warranty, the buyer bears the costs of transport and insurance. If the fault is covered by our warranty, you will receive a new or repaired equipment in return.

Warranty claims are invalid in case of damage resulting from:

- + misuse or improper handling
- + environmental influences (moisture, heat, electrical surge, dust, etc.)
- + failure to follow the current safety measures for the equipment
- + failure to follow the operating instructions
- + use of force (e. g. hitting, kicking, falling)
- + interventions which were not carried out by one of our authorized service centres
- + unauthorised repair attempts

Proof of Purchase and Serial Number

Please make sure that you are able to provide the appropriate receipt when claiming on your warranty. So that we can clearly identify the model of your equipment, and for the purposes of our quality control, you will need to give the serial number of your equipment, when contacting the service team. Where possible please have your serial number and your customer number ready when you call our service hotline. It will help us to deal with your request swiftly.







































If you cannot find the serial number on your fitness equipment, our service team is at your disposal to offer further information.

Service outside of the Warranty Period

We are also happy to issue an individual cost estimate if there is a problem with your fitness equipment after the warranty has expired, or in cases which do not fall under the terms of the warranty, e. g. normal wear and tear. Please contact our customer service team to find a quick and cost-effective solution to your problem. In such a case you will be responsible for the delivery costs.

Communication

Many problems can be solved just by speaking to us as your specialist supplier. We know how important it is to you as a user of the fitness equipment to have problems solved quickly and simply, so you can enjoy working out with minimal interruption. For that reason, we also want to resolve your queries quickly and in a straightforward manner. Thus, please always keep your customer number and the serial number of the faulty equipment handy.

DE	DK	UK
<p>TECHNIK</p> <p> +49 4621 4210-900  +49 4621 4210-698  technik@fitshop.de  Öffnungszeiten entnehmen Sie unserer Homepage.</p> <p>SERVICE</p> <p> 0800 20 20277 (kostenlos)  04621 4210 - 0  info@fitshop.de  Öffnungszeiten entnehmen Sie unserer Homepage: https://stg.fit/statita</p>	<p>TEKNIK OG SERVICE</p> <p> 80 90 16 50 +49 4621 4210-945  info@fitshop.dk  Åbningstider kan findes på hjemmesiden: https://stg.fit/statit7</p>	<p>CUSTOMER CARE</p> <p> +44 141 737 2249 or +44 141 876 3972  customercare@fitshop.co.uk  You can find the opening hours on our homepage: https://stg.fit/statitd</p>
	FR	BE
	<p>TECHNIQUE & SERVICE</p> <p> +33 (0) 189 530984 +49 4621 42 10 933  info@fitshop.fr  Vous trouverez les heures d'ouverture sur notre site Internet: https://stg.fit/statit4</p>	<p>TECHNIQUE & SERVICE</p> <p> 02 732 46 77 +49 4621 4210 933  info@fitshop.be  Vous trouverez les heures d'ouverture sur notre site Internet: https://stg.fit/statit8</p>
ES	NL	INT
<p>TECNOLOGÍA Y SERVICIOS</p> <p> 911 238 029  info@fitshop.es  Consulta nuestro horario de apertura en la página web: https://stg.fit/statit5</p>	<p>TECHNISCHE DIENST & SERVICE</p> <p> +31 172 619961  service@fitshop.nl  De openingstijden vindt u op onze homepage: https://stg.fit/statit3</p>	<p>TECHNICAL SUPPORT & SERVICE</p> <p> +49 4621 4210-944  service-int@fitshop.de  You can find the opening hours on our homepage: https://stg.fit/statita</p>
PL	AT	CH
<p>DZIAŁ TECHNICZNY I SERWIS</p> <p> 22 307 43 21 +49 4621 42 10-948  info@fitshop.pl  Godziny otwarcia można znaleźć na stronie głównej: https://stg.fit/statit6</p>	<p>TECHNIK & SERVICE</p> <p> 0800 20 20277 (Freecall) +49 4621 42 10-0  info@fitshop.at  Öffnungszeiten entnehmen Sie unserer Homepage: https://stg.fit/statitb</p>	<p>TECHNIK & SERVICE</p> <p> 0800 202 027 +49 4621 42 10-0  info@fitshop.ch  Öffnungszeiten entnehmen Sie unserer Homepage: https://stg.fit/statit9</p>

Please find a detailed overview including address and opening hours for all stores of Fitshop UK on the following website:

www.fitshop.co.uk/storelocator

WE LIVE FITNESS

WEBSHOP AND SOCIAL MEDIA

The Fitshop Group is Europe's largest specialist for home fitness equipment with currently 70 stores and one of the world's most renowned online mail order companies for fitness equipment.

Fitshop UK is part of the Fitshop Group. Private customers order via the 25 web shops in the respective national language or have their desired equipment assembled on site. In addition, the company supplies fitness studios, hotels, sports clubs, companies and physio practices with professional equipment for endurance and strength training.

The Fitshop group offers a wide range of fitness equipment from renowned manufacturers, high-quality in-house developments and comprehensive services, such as a build-up service and sports scientific advice before and after the purchase. The company employs numerous sports scientists, fitness trainers and competitive athletes.

Visit us also on our social media platforms or our blog!



<https://www.fitshop.co.uk/>
www.fitshop.co.uk/blog/



www.facebook.com/fitshop.co.uk



www.instagram.com/fitshop_uk



www.youtube.com/@fitshop_uk

TAURUS

 cardiostrong

BODYCRAFT

BodyMax

Notes

Notes

BODYCRAFT