

BODYCRAFT

Assembly and Operating Instructions

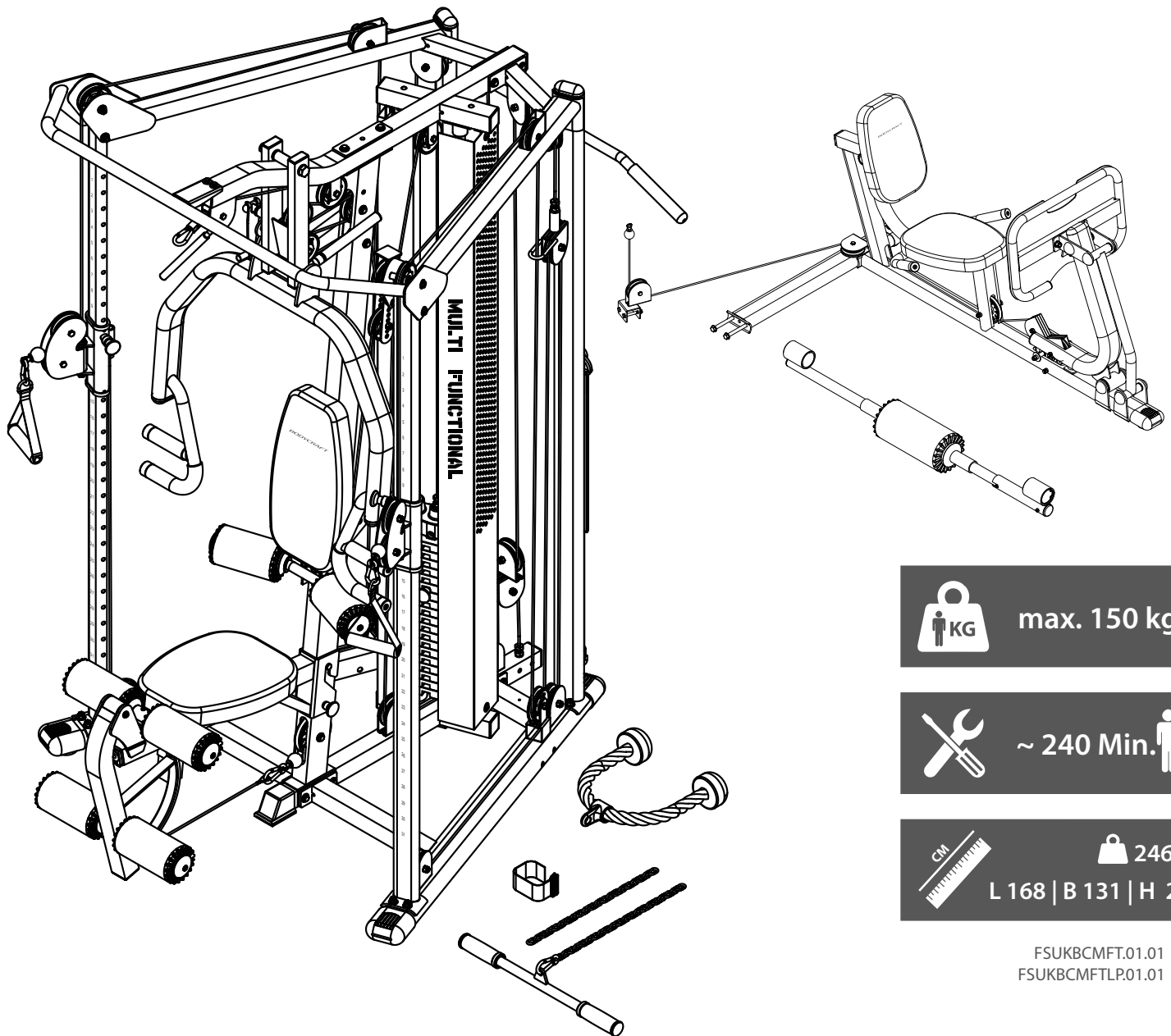

max. 150 kg



~ 240 Min.



246 kg

L 168 | B 131 | H 211

FSUKBCMFT.01.01
FSUKBCMFTLP.01.01

SKU: BC-MFT
BC-MFT-LP
BACK SUPPORT

BodyCraft MFT

Content

1	GENERAL INFORMATION	8
1.1	Technical Data	8
1.2	Personal Safety	10
1.3	Set-Up Place	11
2	ASSEMBLY	12
2.1	General Instructions	12
2.2	Scope of Delivery: MFT	13
2.3	Assembly: MFT	17
2.4	Set-Up Place	41
2.5	Scope of Delivery: Leg Press	42
2.6	Assembly: Leg Press	43
2.7	Assembly: Back Support	54
3	WORKOUT TIPS	56
3.7.1	Training clothes	56
3.7.2	Warming up and stretching	56
3.7.3	Medication	57
3.7.4	Used muscle groups	57
3.7.5	Exercise frequency	57
3.1	Workout journal	59
4	STORAGE AND TRANSPORT	60
4.1	General Instructions	60
4.2	Transportation Wheels	60
5	TROUBLESHOOTING, CARE AND MAINTENANCE	61
5.1	General Instructions	61
5.2	Faults and Fault Diagnosis	61
5.3	Maintenance and Inspection Calendar	62
6	DISPOSAL	62
7	RECOMMENDED ACCESSORIES	63
8	ORDERING SPARE PARTS	64
8.1	Serial Number and Model Name	64
8.2	Parts List: MFT	65
8.3	Parts List: Leg Press	69

8.4	Parts List: Back Support	71
8.5	Exploded Drawing: MFT	72
8.6	Exploded Drawing: Leg Press	73
8.7	Exploded Drawing: Back Support	74
9	WARRANTY	75
10	CONTACT	77

Dear customer,

Thank you for choosing quality training equipment from the TAURUS brand. Taurus offers sports and fitness equipment for home users with high demands on quality, functionality and longevity. Also, Taurus is a well-known and experienced brand for equipping professional rooms for fitness studios and business customers. The focus of Taurus fitness equipment is on what matters most in sports: maximum performance! Therefore, the devices are developed in close consultation with athletes and sports scientists. Because athletes know best what makes perfect fitness equipment.

Further information can be found at www.fitshop.co.uk

Intended Use

The equipment may only be used for its intended purpose.

The equipment is only suitable for home use. The equipment is not suitable for semi-professional (e.g. hospitals, associations, hotels, schools, etc.) and commercial or professional use (e.g. fitness studios).

Legal Notice

Fitshop GmbH
Europe's No. 1 for home fitness

International Headquarters
Flensburger Straße 55
24837 Schleswig
Germany

Management:
Christian Grau
Sebastian Campmann
Dr. Bernhard Schenkel
No. HRB 1000 SL
Local Court Flensburg
European VAT Number: DE813211547

Disclaimer

BodyCraft® is a registered brand of the company Fitness Authority Industrial Co., LTD. All rights reserved. Any use of this trademark without the explicit written permission of Fitness Authority Industrial Co., LTD is prohibited.

BODYCRAFT

Product and manual are subject to change. Technical data can be changed without advance notice.

ABOUT THIS MANUAL

Please carefully read the entire manual before installation and first use. The manual will help you to quickly set up the system and explains how to safely use it. Make sure that all persons exercising with the equipment (especially children and persons with physical, sensory, mental or motor disabilities) are informed about this manual and its contents in advance. In case of doubt, responsible persons must supervise the use of the equipment.

Due to ongoing changes and software optimisations, the manual may have to be updated. If you notice any discrepancies during assembly or use, please refer to the manual uploaded to the webshop. The latest manual is always available there.



This equipment has been manufactured according to the latest safety knowledge. As far as possible, potential safety hazards which could cause injury have been eliminated. Make sure to carefully follow the instructions and that all parts are securely in place. If required, read through the instructions again to correct any mistakes.

Training devices must be classified according to accuracy and use. Accuracy classes are only applicable to devices that display training data.

Accuracy classes

Class A: high accuracy.

Class B: medium accuracy.

Class C: low accuracy.

The use classes explain the intended use of the training device.

Use classes

Class S (studio): professional and/or commercial use.

These training devices are intended for the use in training rooms of facilities such as sports clubs, school facilities, hotels, clubs and studios whose access and supervision is specifically regulated by the owner (person with legal responsibility).

Class H (home use): use at home.

These stationary training devices are intended for the use in private homes where access to the training device is regulated by the owner (person with legal responsibility).

Please pay close attention to the safety and maintenance instructions given here. The contract partner cannot be held liable for damage to health, accidents or damage to the equipment when it is not used in accordance with these instructions.

The following safety instructions may appear in this manual:

► **ATTENTION**

This notice indicates potentially hazardous situations which, if not avoided, may result in property damage.



CAUTION

This notice indicates potentially hazardous situations which, if not avoided, may result in slight or minor injuries!



WARNING

This notice indicates potentially hazardous situations which, if not avoided, may result in death or serious injuries!



DANGER

This notice indicates potentially hazardous situations which, if not avoided, will result in death or serious injuries!



NOTICE

This notice indicates further useful information.

Retain these instructions in a safe place for future reference, maintenance or when ordering replacement parts.

1.1 Technical Data

Weight and Dimensions:

MFT:

Product weight (gross, incl. packaging):

Box 1:	52.1 kg
Box 2:	53.5 kg
Box 3:	58.8 kg
Box 4:	11.2 kg
Box 5:	32 kg
Box 6:	32 kg
Box 7:	32 kg

Product weight (net, without packaging): 245.7 kg

Packaging dimensions (L x W x H):

Box 1:	201.9 cm x 47.9 cm x 174 cm
Box 2:	109.8 cm x 93.3 cm x 16.1 cm
Box 3:	140.3 cm x 79.3 cm x 20.9 cm
Box 4:	191.7 cm x 22.2 cm x 12.7 cm
Box 5:	26.9 cm x 20.3 cm x 12.7 cm
Box 6:	26.9 cm x 20.3 cm x 12.7 cm
Box 7:	26.9 cm x 20.3 cm x 12.7 cm

Assembled dimensions (L x W x H): 168 cm x 131 cm x 211 cm

Maximum user weight: 150 kg

Maximum load: 90 kg

Use class: S

Leg Press:

Product weight (gross, incl. packaging): 54 kg

Product weight (net, without packaging): 48.8 kg

Packaging dimensions (L x W x H): 171.2 cm x 60 cm x 18.5 cm

Assembled dimensions (L x W x H): 172 cm x 97 cm x 88 cm

Total dimensions BC-MFT+BC-MFT-LP (L x W x H) : 168 cm x 230 cm x 211 cm

Back Support:

Product weight (gross, incl. packaging): 2.3 kg

Product weight (net, without packaging): 1.9 kg

Product dimensions (L x W x H): 11 cm x 11 cm x 90 cm

1.2 Personal Safety

DANGER

- + Before you start using the equipment, you should consult your physician that this type of exercise is suitable for you from a health perspective. Particularly affected are persons who: have a hereditary disposition to high blood pressure or heart disease, are over the age of 45, smoke, have high cholesterol values, are overweight and/or have not exercised regularly in the past year. If you are under medical treatment that affects your heart rate, medical advice is absolutely essential.
- + Note that excessive training can seriously endanger your health. Please also note that heart rate monitoring systems can be inaccurate. If you notice any signs of weakness, nausea, dizziness, pain, shortness of breath, or other abnormal symptoms, stop exercising immediately and seek advice from your doctor if necessary.
- + The owner must communicate all warnings and instructions to the user.

WARNING

- + This equipment may not be used by children under the age of 14.
- + Children should not be allowed unsupervised access to the equipment.
- + Persons with disabilities must have a medical license and must be under strict observation when using the equipment.
- + The equipment is strictly for use by one person at a time.
- + Keep your hands, feet and other body parts, hair, clothing, jewellery and other objects well clear of moving parts.
- + During use, wear suitable sports clothing rather than loose or baggy clothing. When wearing sports shoes, make sure they have suitable soles, preferably made of rubber or other non-slip materials. Shoes with heels, leather soles, studs or spikes are unsuitable. Never exercise barefoot.
- + Always start each workout with a light warm-up and end with a cool-down phase.
- + Using the machine as a support during stretching exercises or attaching resistance bands, ropes or other accessories to it, may cause injuries.

CAUTION

- + If your equipment needs to be connected to the power supply with a mains cable, make sure that the cable is not a potential tripping hazard.
- + Make sure that nobody is within the range of motion of the equipment during training so as not to endanger you or other persons.
- + Be aware that if adjustment devices are left protruding, they may impede the user's movement.
- + The weights should remain in the user's field of vision during the entire exercise to prevent danger to third parties.

ATTENTION

- + Do not insert any objects of any kind into the openings of the device.

1.3 Set-Up Place

⚠ WARNING

- + Do not place the equipment in main corridors or escape routes.

⚠ CAUTION

- + Choose a location in which to place the equipment such that there is enough free space/clearance to the front, the rear and to the sides of the equipment.
- + The training room should be well ventilated during training and not be exposed to any draughts.
- + Choose the place in which to set up the equipment such that there is enough free space/clearance to the front, the rear and to the sides of the equipment.
- + The free area in the direction from which the exercise equipment is accessed must be at least 0.6 m larger than the exercise area.
- + The set-up and mounting surface of the equipment should be flat, loadable and solid.
- + If your device is to be mounted on the wall/ceiling, make sure that you use the appropriate assembly material to avoid possible damages or personal injuries. The contractual partner accepts no liability for this.

▶ ATTENTION

- + The device may only be used in one building, in sufficiently tempered and dry rooms (ambient temperatures between 10°C and 35°C). The equipment should not be used outdoors or in rooms with high humidity (over 70%) like swimming pools.
- + A floor protective mat/equipment underlay can help to protect high-quality floor coverings (parquet, laminate, cork, carpets) from dents and sweat and can help to level out slight unevenness.
- + For Class S equipment, the exercise equipment may only be used in areas where access, supervision and control are specifically regulated by the owner.

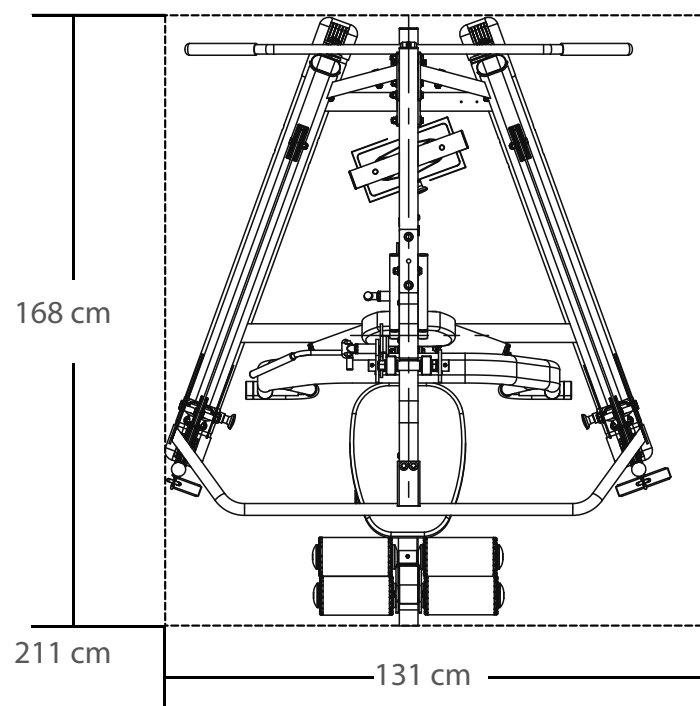

2.1 General Instructions

⚠ DANGER

- + Do not leave any tools, packaging materials such as foils or small parts lying around, as otherwise there is a danger of suffocation for children. Keep children away from the equipment during assembly.

⚠ WARNING

- + Pay attention to the instructions attached to the equipment in order to reduce the risk of injuries.

⚠ CAUTION

- + Ensure to have sufficient room for movement in each direction during assembly.
- + The assembly of the equipment must be carried out by at least two adults. If in doubt, seek the help of a third technically skilled person.

▶ ATTENTION

- + To prevent damage to the equipment and the floor, assemble the equipment on a mat or packaging board.

ⓘ NOTICE

- + In order to make the assembly as simple as possible, some screws and nuts to be used can already be pre-assembled.
- + Ideally, assemble the equipment at its later set-up place.

2.2 Scope of Delivery: MFT

The scope of delivery consist of the following parts. At the beginning, check whether all parts and tools belonging to the device are included in the scope of delivery and whether damage has occurred. In the event of complaints, the contractual partner must be contacted directly.

CAUTION

If parts of the scope of delivery are missing or damaged, the assembly must not be carried out.

Required and recommended tools:

Allen key, wrench, ratchet, rubber mallet, silicone spray

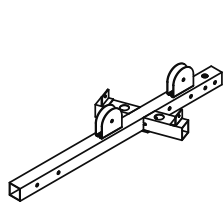

(1) MAIN FRAME

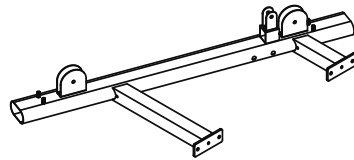

(2R) RIGHT BASE FRAME

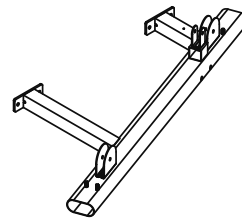

(3L) LEFT BASE FRAME

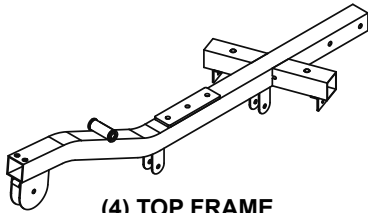

(4) TOP FRAME

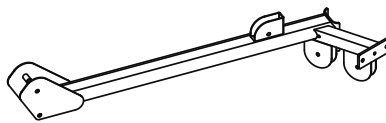

(5R) RIGHT TOP FRAME

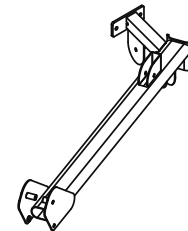

(6L) LEFT TOP FRAME



(7) VERTICAL
GUIDE ROD
X 2pcs



(8R) RIGHT
UPRIGHT
FRAME



(9L) LEFT
UPRIGHT
FRAME

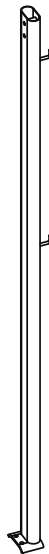

(10) REAR
UPRIGHT
FRAME
X 2pcs

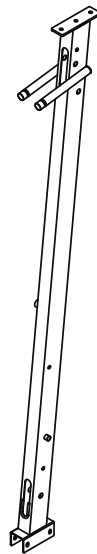

(11) SUPPORT
UPRIGHT
FRAME

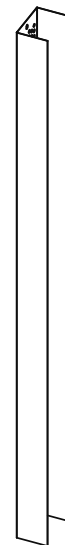

(12R) RIGHT
WEIGHT
SHROUD



(13L) LEFT
WEIGHT
SHROUD

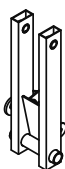

(16) PRESS ARM
SUPPORT

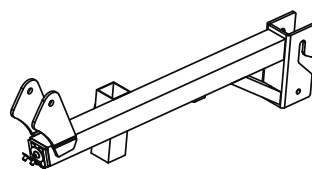

(17) SEAT FRAME

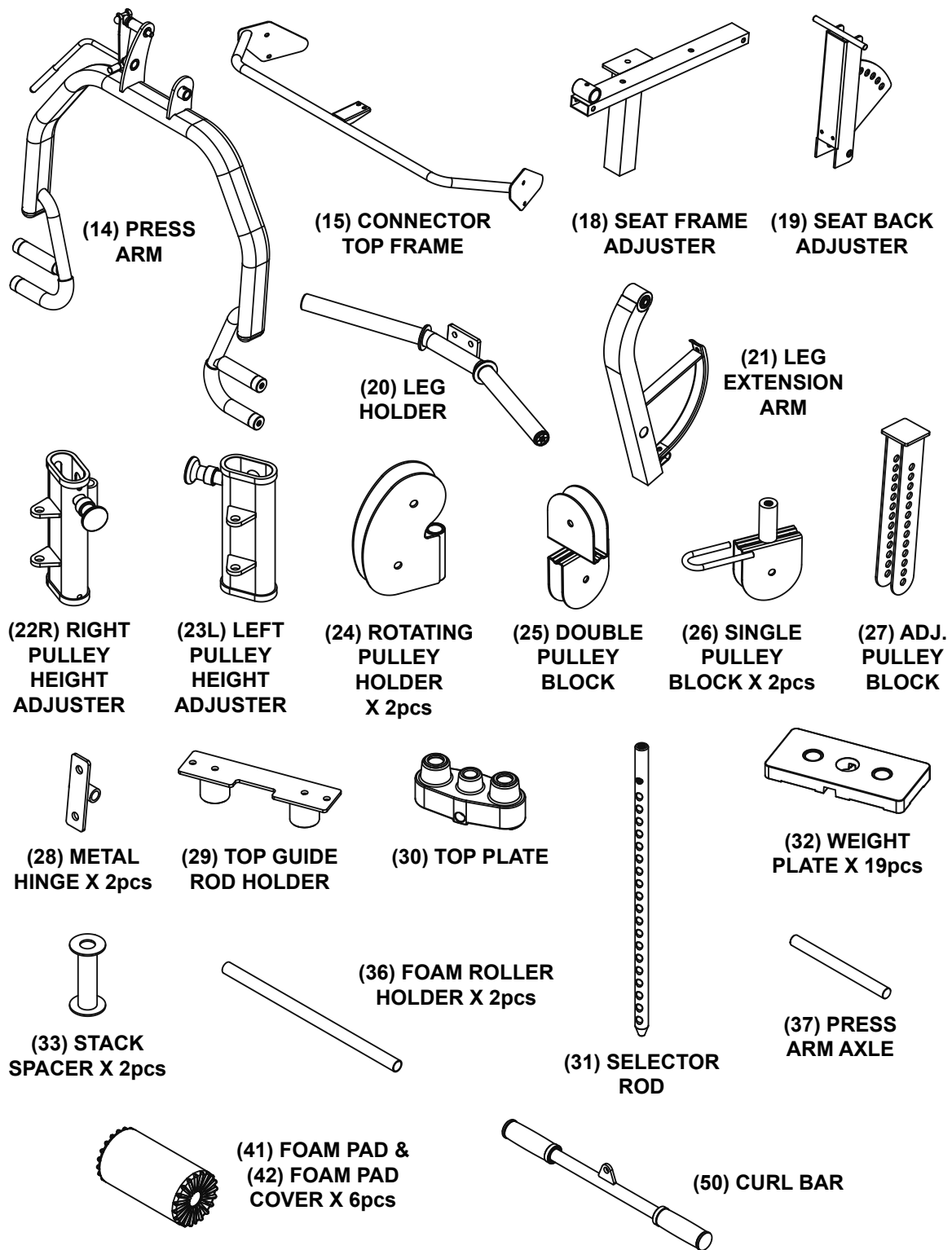

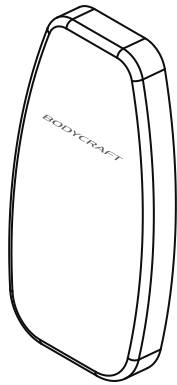

(39) BACK PAD

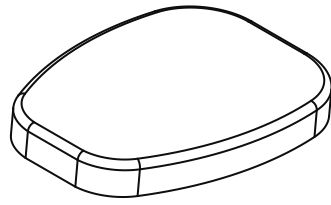

(40) SEAT PAD

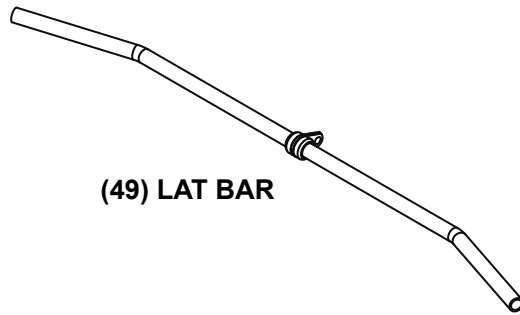

(49) LAT BAR



(51) SPORT BAR



(52) LONG BAR



(56) CHIN ASSIST STRAP



(57) ANKLE STRAP

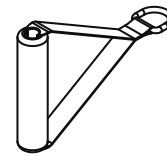

(58) SINGLE HANDLE X 2pcs



(61) SNAP HOOK X 5pcs

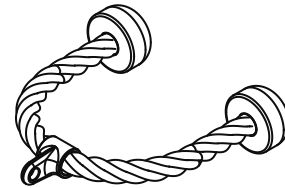

(59) TRICEP ROPE

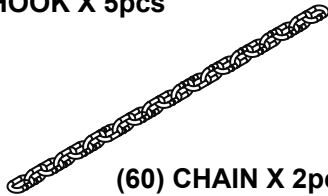

(60) CHAIN X 2pcs



(66) 140mm PULLEY



(67) 90mm PULLEY X 33pcs

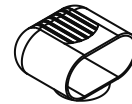

(68) 50 X 100mm OVAL END CAP X 4pcs

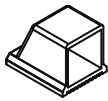

(69) 50 X 50mm END CAP



(70) 50 X 50mm END PLUG X 8pcs

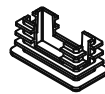

(71) 25 X 50mm END PLUG X 6pcs

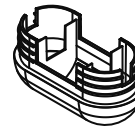

(72) 40 X 80mm ROUND PLUG FOR UPRIGHT FRAME X 2pcs

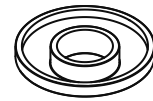

(75) PLASTIC CAP X 6pcs

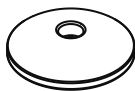

(76) ALUMINUM CAP X 6pcs

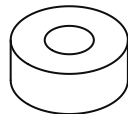

(77) RUBBER CUSHION X 4pcs



(81) PLASTIC GUIDE ROD HOLDER X 2pcs



(85) 3/8" BUSHING X 6pcs

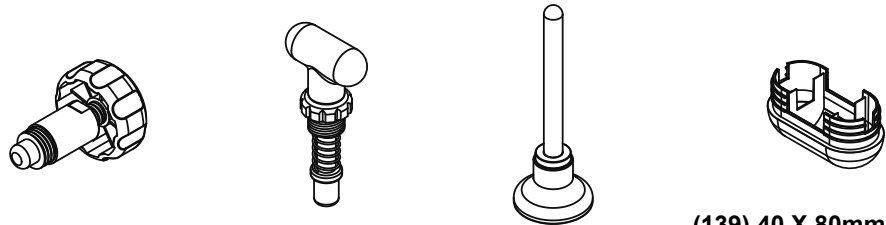

(91) SPRING KNOB

(93) SHORTER POP PIN

(95) SELECTOR PIN X 2pcs

(139) 40 X 80mm OVAL PLUG FOR PRESS ARM X 2pcs

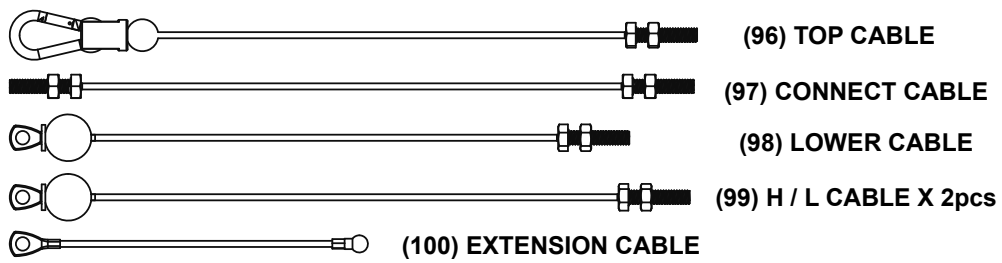

(96) TOP CABLE

(97) CONNECT CABLE

(98) LOWER CABLE

(99) H / L CABLE X 2pcs

(100) EXTENSION CABLE

NO.	DESCRIPTION	QTY.
101	5/8" X 5-1/2" HEX BOLT	21
102	1/2" X 4-1/4" HEX BOLT	2
103	3/8" X 4-1/4" HEX BOLT	4
104	3/8" X 3-1/2" HEX BOLT	2
105	3/8" X 3-1/8" HEX BOLT	6
106	3/8" X 3" HEX BOLT	1
107	3/8" X 2-3/4" HEX BOLT	3
108	3/8" X 2-1/2" HEX BOLT	4
109	3/8" X 1-3/4" HEX BOLT	29
110	3/8" X 1-3/4" HEX THREADED BOLT	2
111	3/8" X 1" HEX THREADED BOLT	4
112	TOP PLATE BOLT	1
117	5/16" X 1/2" BUTTON HEAD BOLT	4
125	5/8" WASHER	2
126	1/2" WASHER	4
128	3/8" SMALLER WASHER	44
130	5/16" SMALLER WASHER	4
132	5/8" NYLON NUT	1
133	1/2" NYLON NUT	2
134	3/8" NYLON NUT	47
137	4mm HEX WRENCH	1
138	5mm HEX WRENCH	1

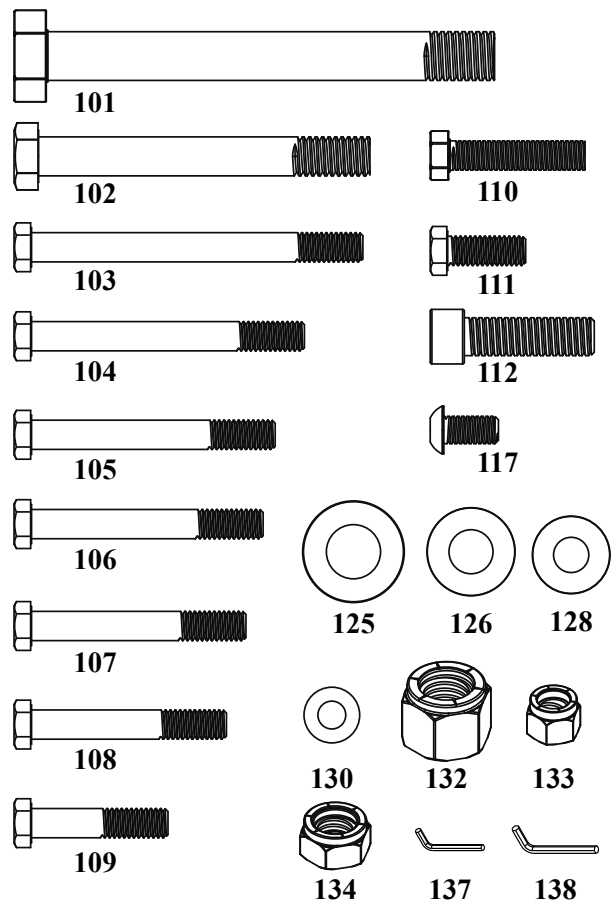

101

102

103

104

105

106

107

108

109

110

111

112

117

125

126

128

130

132

133

134

137

138

2.3 Assembly: MFT

Before assembly, take a close look at the individual assembly steps shown and carry out the assembly in the order given.

① NOTICE

- + First loosely screw all parts together and check that they fit properly. Tighten the screws using the tool only when you are instructed to do so.
- + Do not tighten the screws and bolts with excessive force as they could be damaged.
- + If you have difficulty recognising the graphics, we recommend that you open and/or download the PDF instructions stored in the webshop on your end device (e.g. smartphone, tablet or PC). There you have the option of zooming in closer. Please note that the Adobe Acrobat Reader programme must be installed on your end device in order to open the file.

Step 1: Assemble the base frame

1. Place two 50 x 100 mm oval end caps (68) on the right base frame (2R) and the left base frame (3L).
2. Place three end plugs (70) and one 50 x 50 mm end cap (69) on the main frame (1).
3. Attach the right base frame (2R) and the left base frame (3L) to the main frame (1) and the support upright frame (11) with two hex bolts (104), two hex bolts (105), eight washers (128), and four nylon nuts (134).
4. Tighten the bolts.

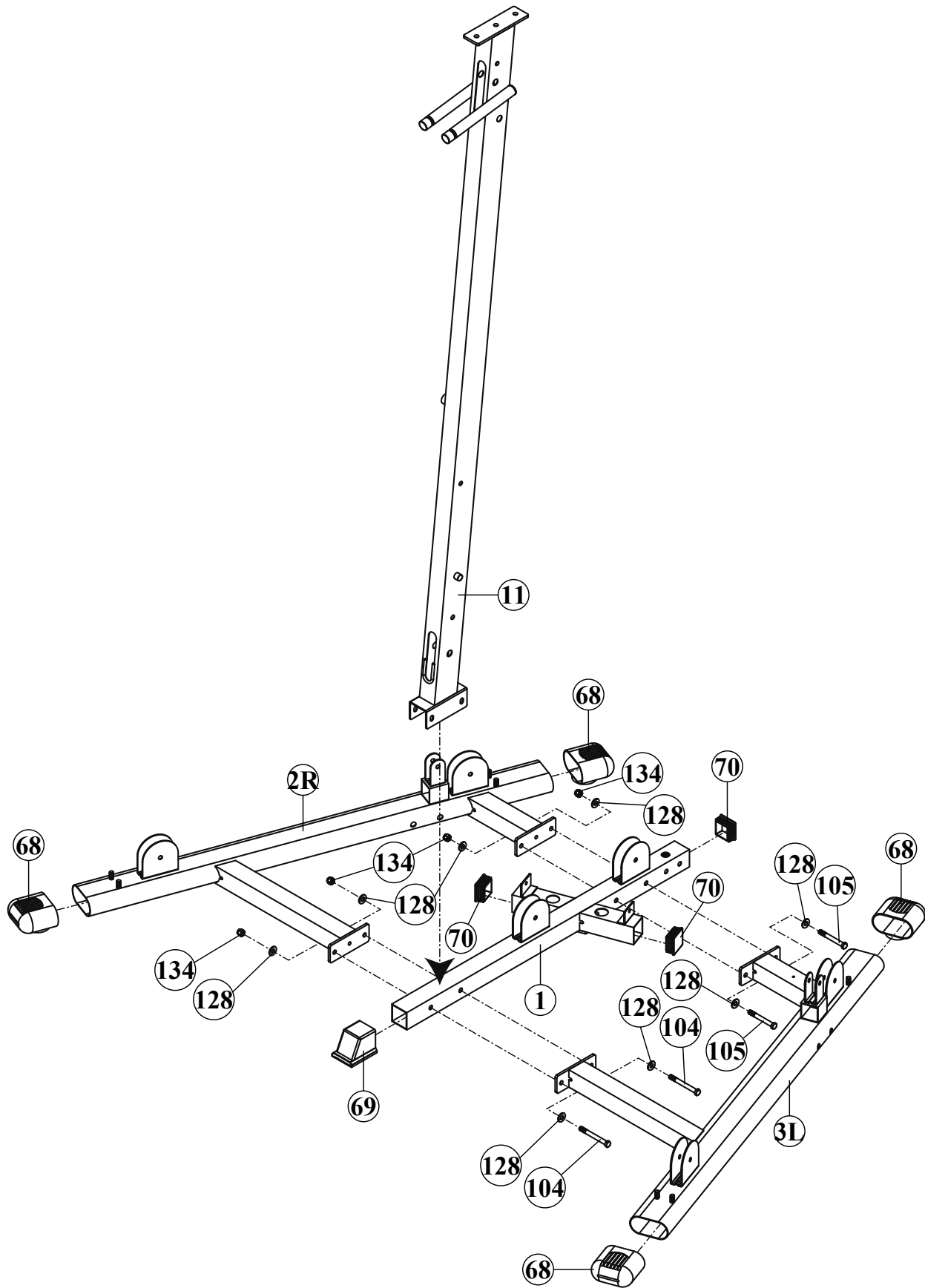

Step 2: Assemble the base frame

1. Place one oval plug for the upright frame (72) on the rear upright frame (10).
2. Attach the right and left upright frames (8R & 9L) to the right and left base frames (2R & 3L) with four washers (128) and four nylon nuts (134).
3. Attach two rear upright frames (10) to the right and left base frames (2R & 3L) with four washers (128) and four self-locking nuts (134).
4. Attach a rotating pulley holder (24) to the right pulley height adjuster (22R) with a hex bolt (102), two washers (126), and a nylon nut (133).
5. Attach the right pulley height adjuster (22R) to the right upright frame (8R).
6. Repeat steps 4 and 5 for the left upright frame (9L).
7. Tighten the bolts.

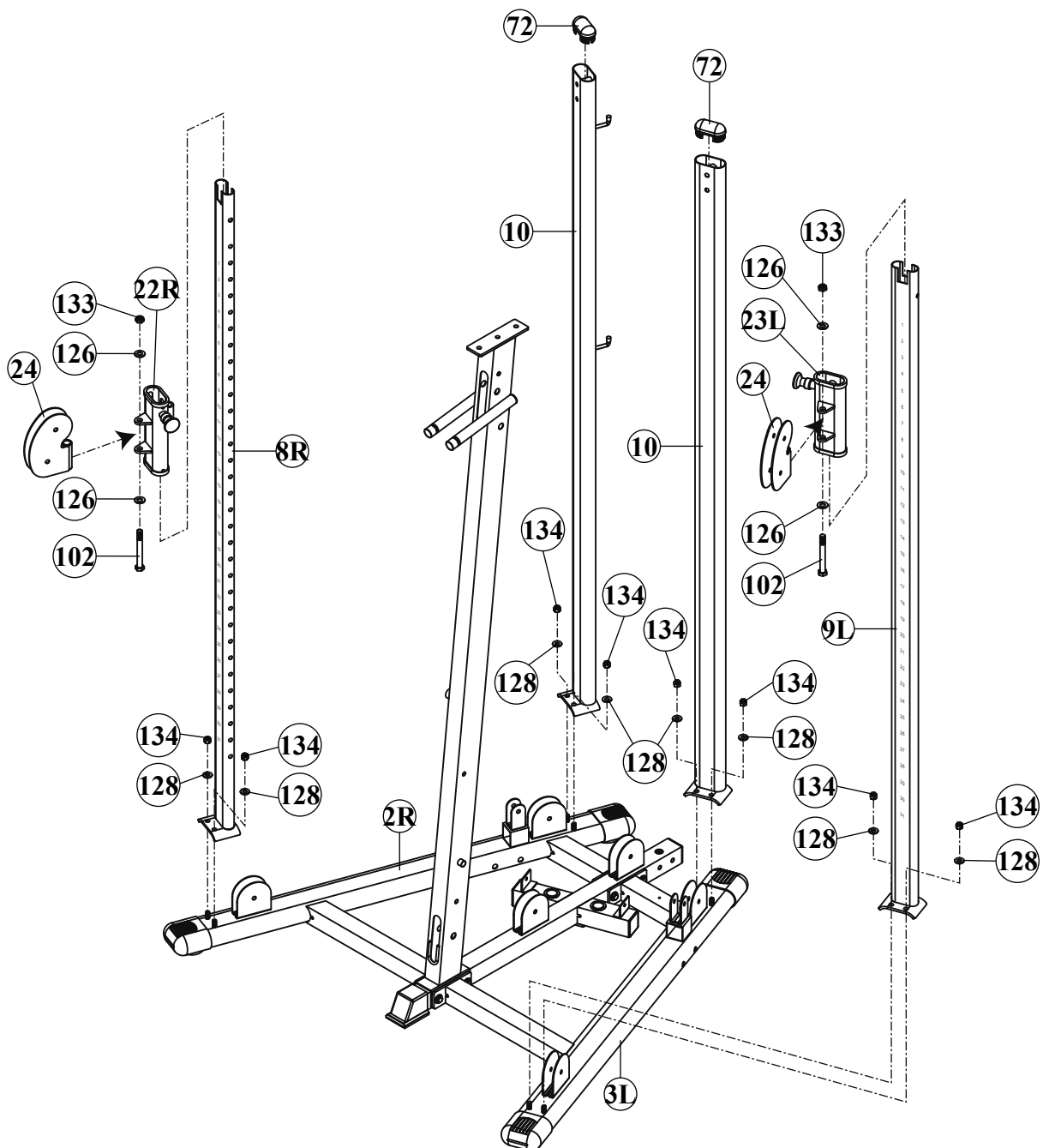

Step 3: Assemble the base frame

1. Place four 50 x 50 mm end plugs (70) on the upper frame (4).
2. Attach the top frame (4) to the support upright frame (11) with two hex bolts (105), four washers (128), and two nylon nuts (134).
3. Place four 25 x 50 mm end plugs (71) on the press arm support (16).
4. Attach the arm press support (16) to the top frame (4) with a hex bolt (101), two washers (125), and a nylon nut (132).
5. Tighten the bolts.

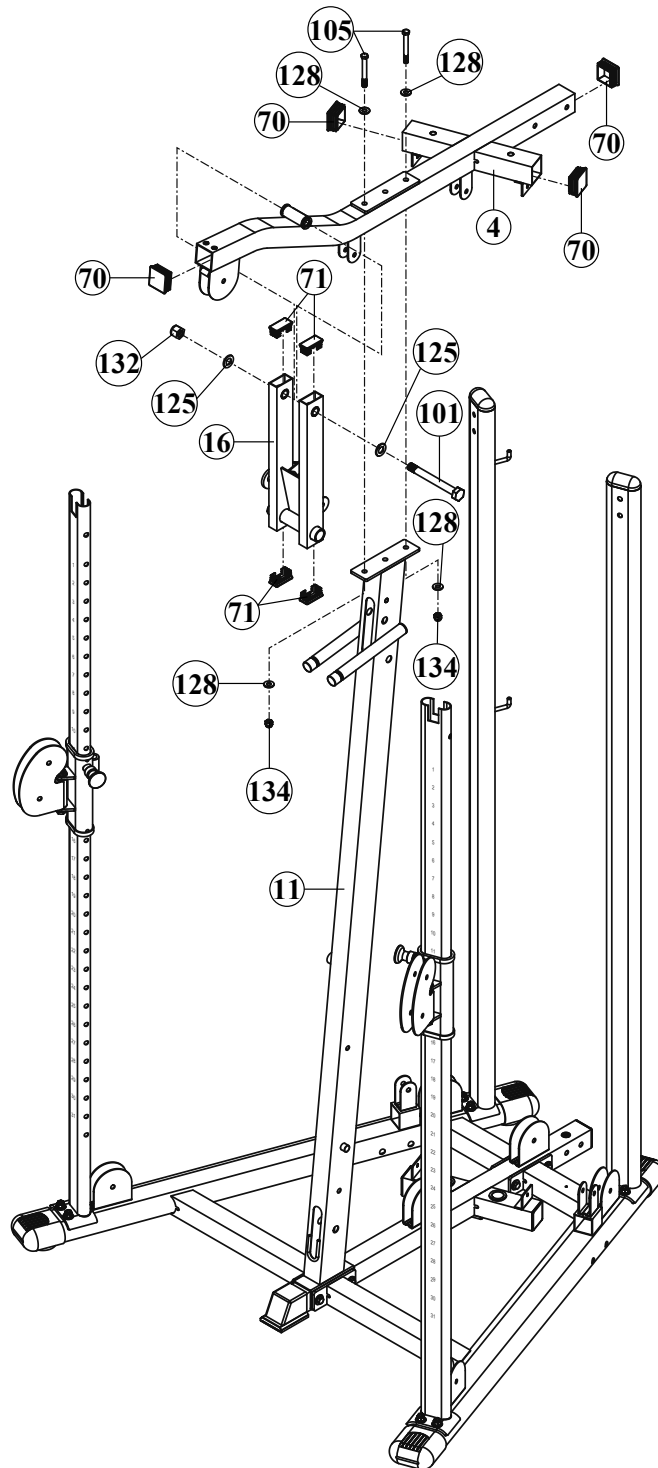

Step 4: Assemble the connecting frame

1. Attach the right and left top frames (5R & 6L) to the top frame (4) with two hex bolts (105), four washers (128), and two nylon nuts (134).
- 1.1. Attach the two rear upright frames (10) to the right and left top frames (5R & 6L) with four hex bolts (108), six washers (128), and three nylon nuts (134).

① **NOTE**

Ensure that step 3 and step 3.1 are performed simultaneously.

2. Attach the upper connector top frame (15) to the right and left top frames (5R & 6L) with four hex bolts (103), eight washers (128), and four self-locking nuts (134).
3. Attach one pulley (67) to both the left and right top frames (6L & 5R).
4. Attach the connector top frame (15) to the top frame (4) with two flat-head screws (116) and two washers (130).
5. Tighten the bolts.

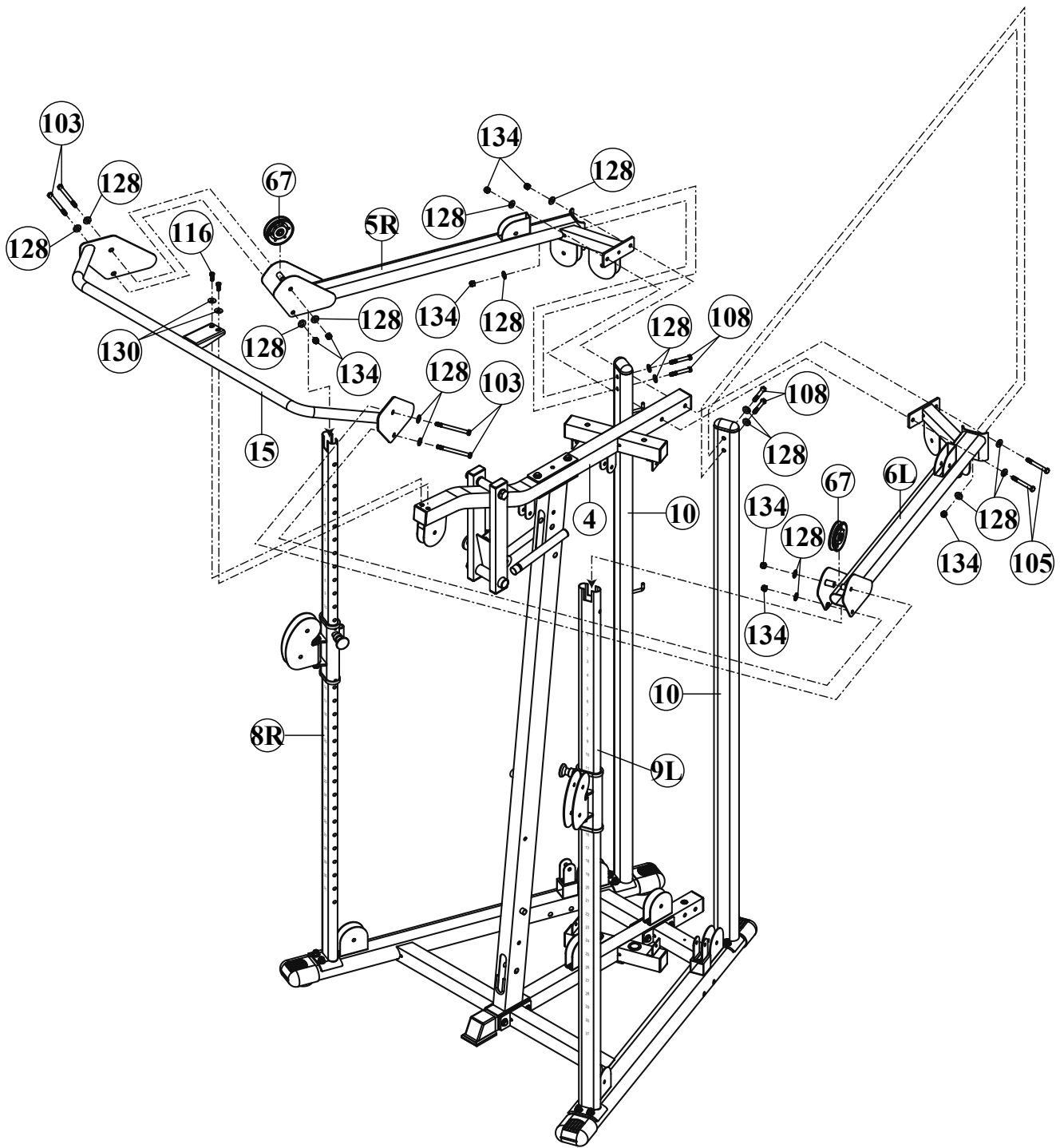

Step 5: Install the weight block

CAUTION

- + Do not install the spacers if you are using 19 weight plates.
- + If you are using the 150-pound block consisting of 14 weight plates, install the spacers (33) on the weight rails (7).
- + If you are using the 200-pound block consisting of 19 weight plates, do not use the spacers.

1. Attach the top plate (30) to the weight shaft (31) with a screw (112).
2. Tighten the screw (112).
3. Insert the plastic guide rod holders (81) into the main frame (1) and insert the guide rods (7).

NOTE

If you are using 19 weight plates (32), skip the spacers (36) and follow Figure 2.

4. Tilt the two guide rods (7) slightly forward.
5. If necessary, insert the spacers (33).
6. Slide four rubber buffers (77) and the weight plates (32) individually onto the guide rods (7).

NOTE

When inserting the weight plates (32), make sure each plate is aligned with the opening for the selection pin facing down and forward.

7. Attach the upper guide rod holder (29) to the guide rods (7) and return them to an upright position.
8. Secure the guide rods (7) with two inner hex bolts (121).
9. Attach the upper guide rod holder (29) to the upper frame (4) with two flat-head screws (116).

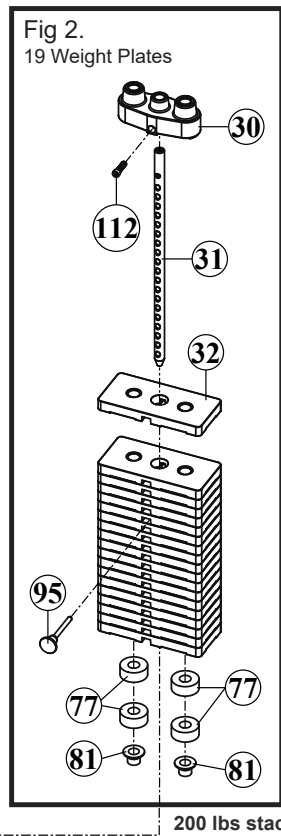
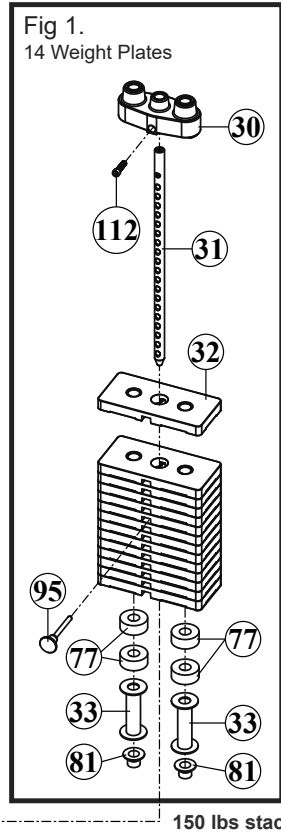
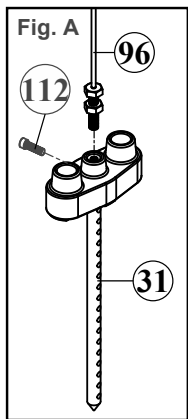
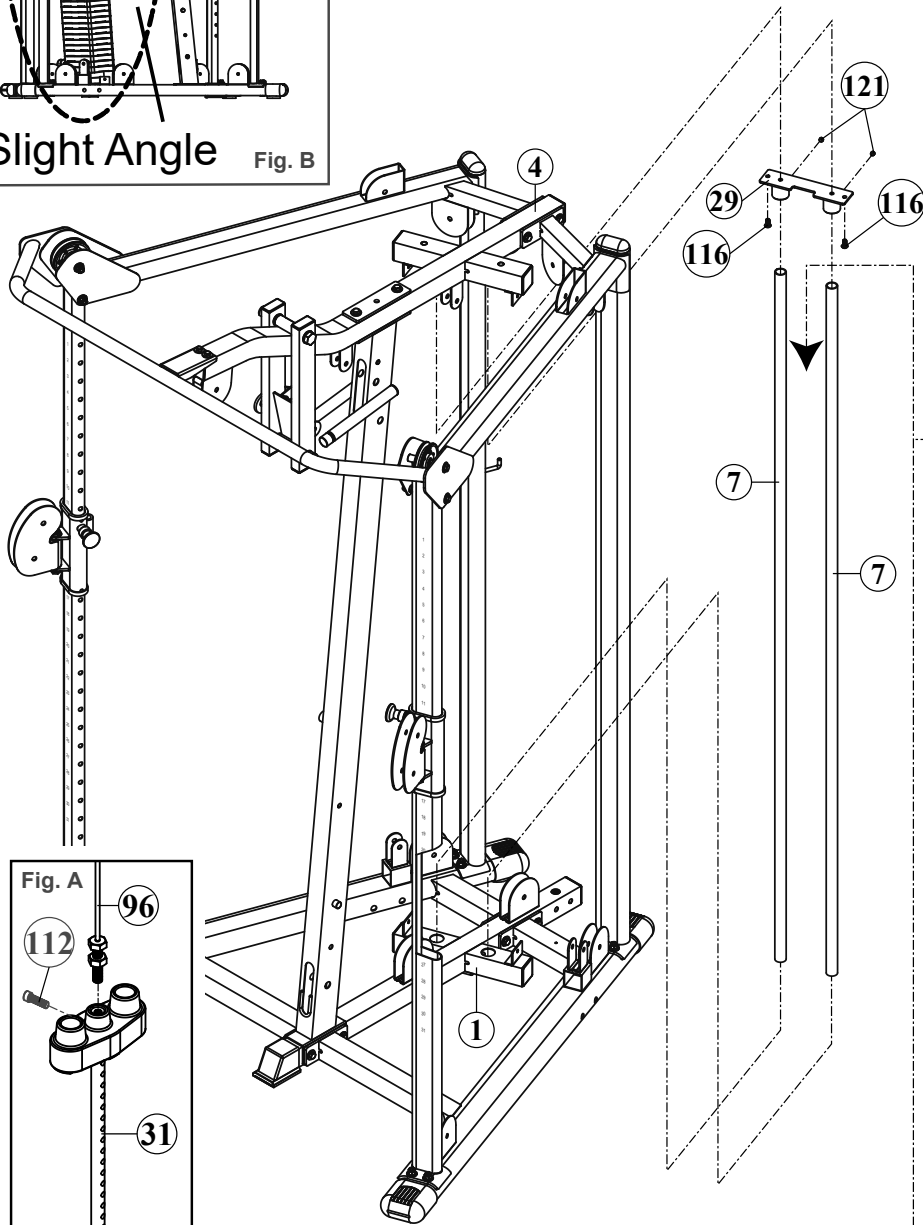
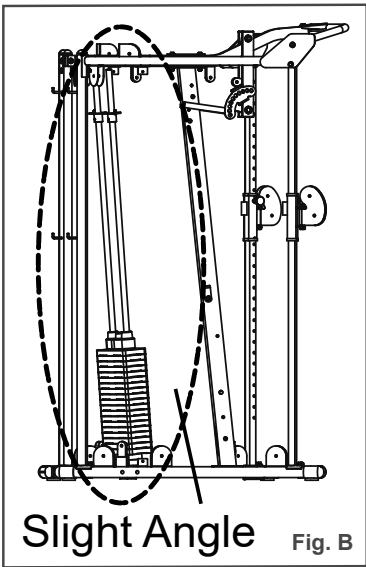

Step 6: Attach the Cable Pulley

ⓘ **NOTE**

- + Install the cables and pulleys simultaneously.
- + To improve the readability of the instructions, the part number for the pulleys is omitted. The number is (67).

1. Insert the end of the upper cable (96) into the opening at the front of the upper frame (4) and guide it over pulleys T1 and T2, which are mounted on the upper frame (4).
2. Attach the pulleys with a hex bolt (109) and a self-locking nut (134) each.
3. Guide the cable towards to the arm press support (16).
4. Attach pulley T3 with a hex bolt (109) and a self-locking nut (134) to the arm press support (16).
5. Guide the cable over pulley T3.
6. Attach pulley T4 to the support frame (11) with a hex bolt (107), two washers (128), two bushings (85), and a self-locking nut (134).
7. Guide the cable over pulley T4.
8. Attach pulley T5 to the arm press support (16) with a hex bolt (109) and a self-locking nut (134).
9. Guide the cable over pulley T5.
10. Attach pulley T6 to the support frame (11) with a hex bolt (107), two washers (128), two bushings (85), and a self-locking nut (134).
11. Guide the cable over pulley T6.
12. Attach pulley T7 to the adjustment bracket (27) with a hex bolt (109) and a self-locking nut (134).
13. Guide the cable over pulley T7.
14. Attach pulley T8 to the upper frame (4) with a hex bolt (109) and a self-locking nut (134).
15. Guide the cable over pulley T8 on the rear bracket of the upper frame (4).
16. Attach pulley T8 with a hex bolt (109) and a self-locking nut (134).
17. Guide the cable over pulley T8.
18. Attach the upper cable (96) to the upper plate (30). (See T9)

ⓘ **NOTE**

You can adjust the tension with the end of the upper cable. However, at least one-third of the thread should always be screwed into the upper plate (30).

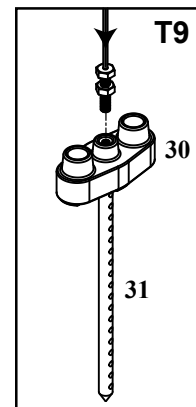
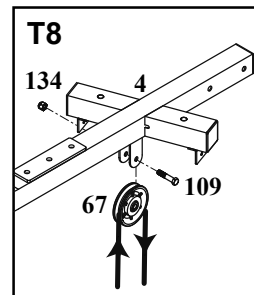
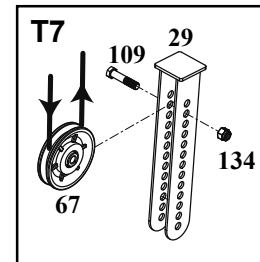
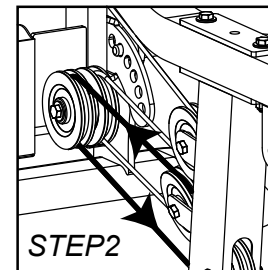
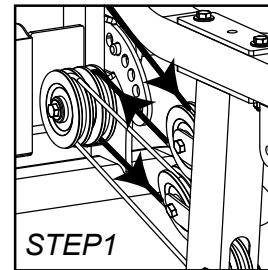
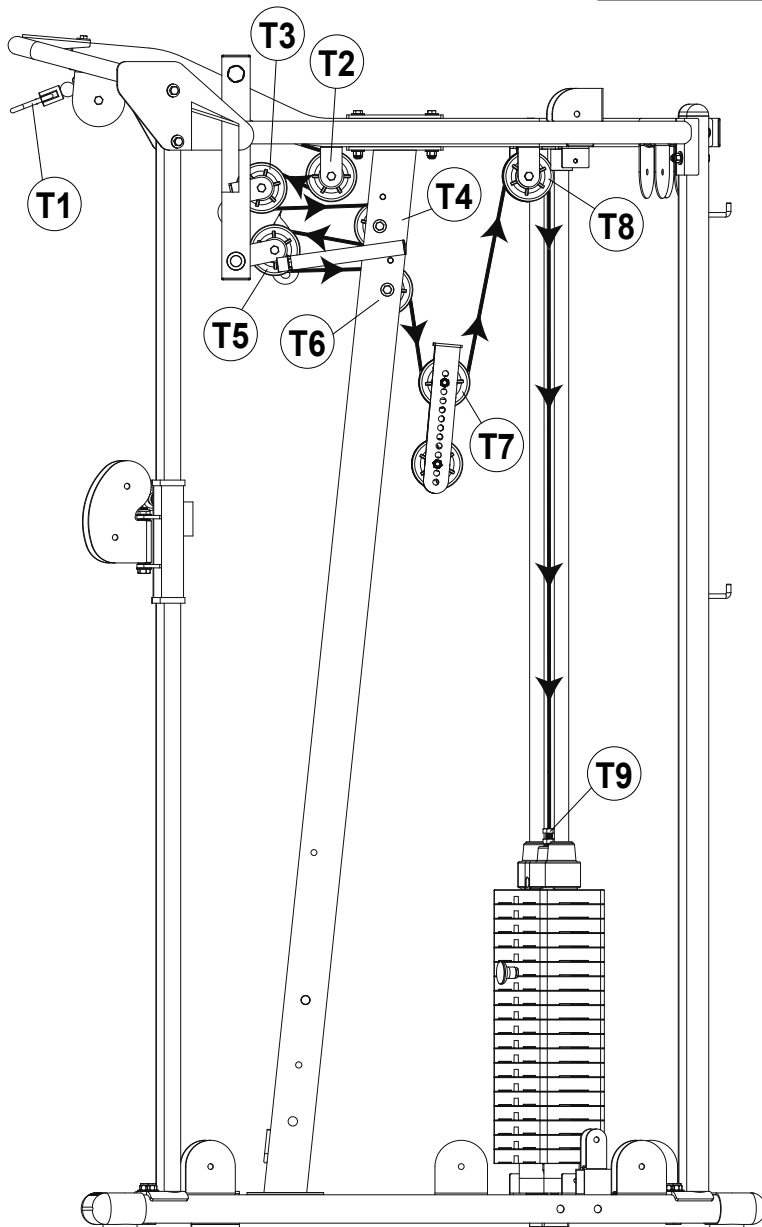
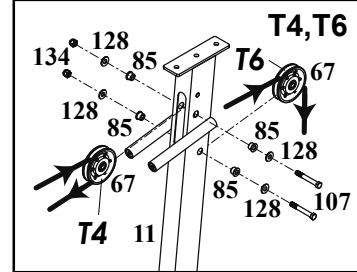
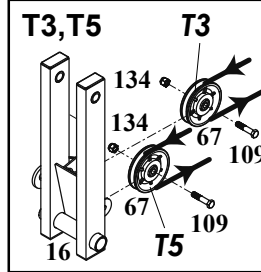
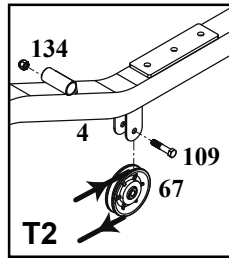
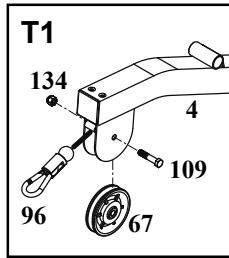
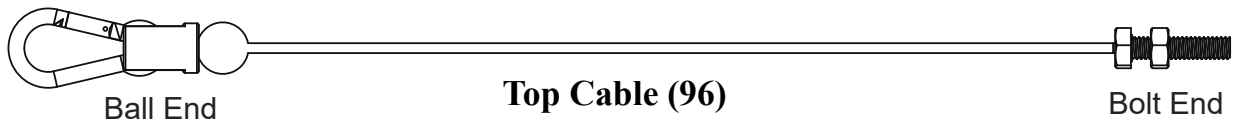

Step 7: Attach the Cable System

① NOTE

- + Install the cables and pulleys simultaneously.
- + To improve the readability of the instructions, the part number for the pulleys is omitted. The number of the pulleys is (67).

1. Connect the connect cable (97) to the single pulley block (26). (See C1)
2. Attach pulley C2 to the right top frame (5R) using a hex bolt (109) and a self-locking nut (134).
3. Route the cable over pulley C2.
4. Attach pulley C3 to the right top frame (5R) using a hex bolt (109) and a self-locking nut (134).
5. Route the cable underneath pulley C3.
6. Attach pulley C4 to the left top frame (6L) using a hex bolt (109) and a self-locking nut (134).
7. Route the cable underneath pulley C4.
8. Attach pulley C5 to the right top frame (5R) using a hex bolt (109) and a self-locking nut (134).
9. Route the cable underneath pulley C5.
10. Attach pulley C6 to the left top frame (6L) using a hex bolt (109) and a self-locking nut (134).
11. Connect the connect cable (97) to the bolt end of the single pulley block (26). (See C7)

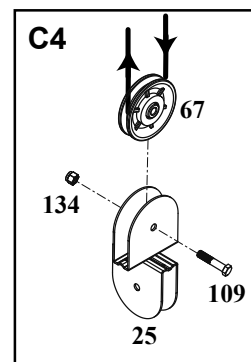
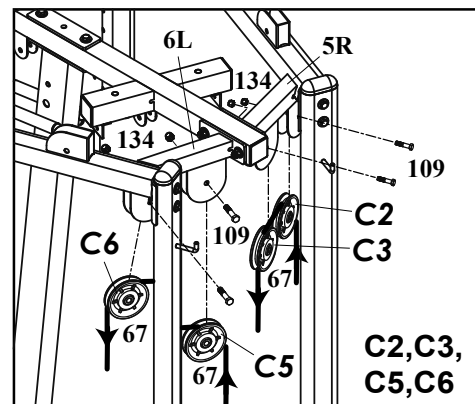
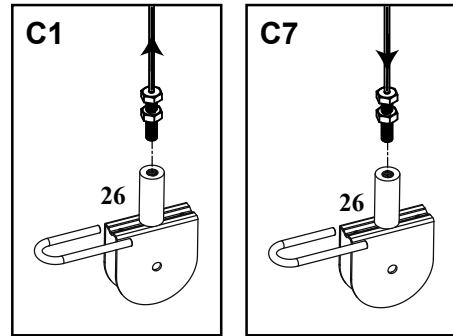
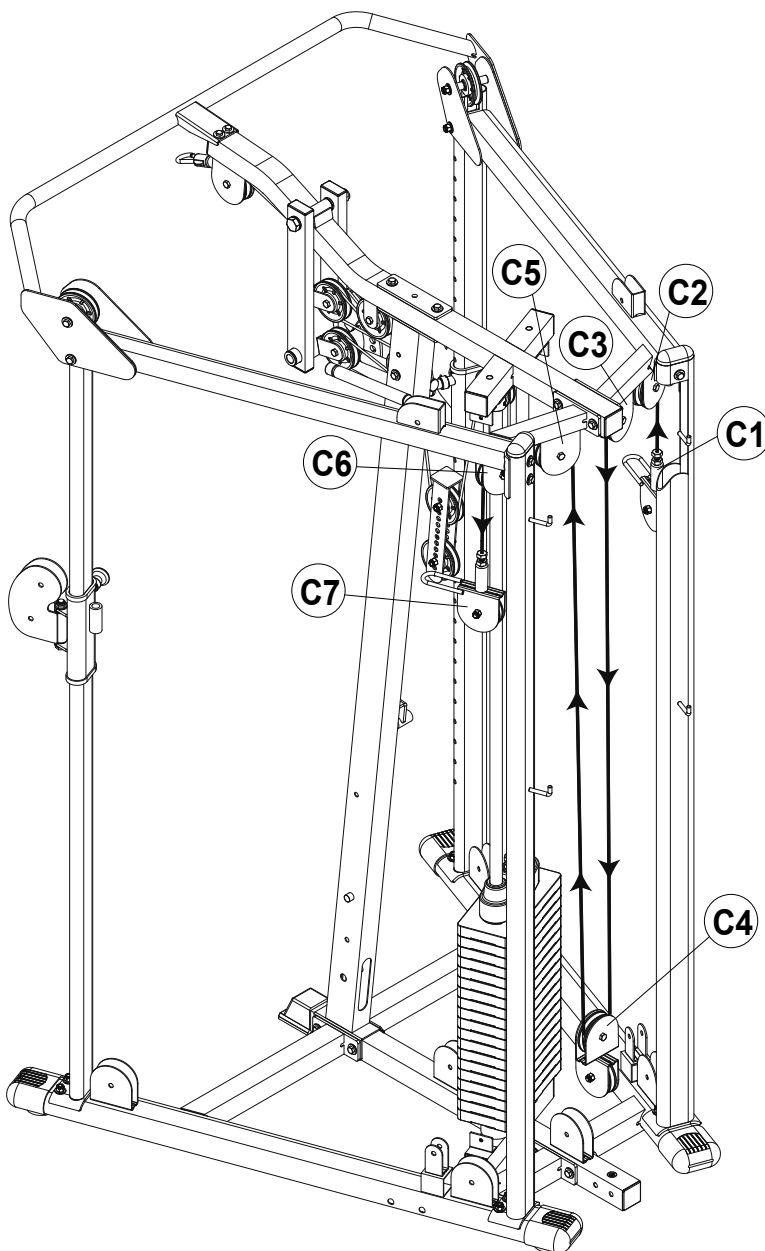

Step 8: Attach the Cable System

① NOTE

- + Install the cables and pulleys simultaneously.
 - + To improve the readability of the instructions, the part number for the pulleys is omitted. The number of the pulleys is (67).
1. Attach pulley L1 to the support upright frame (11) using a hex bolt (107), two bushings (85), two washers (128), and a self-locking nut (134).
 2. Route the ball end of the lower cable (98) around pulley L1.
 3. Attach pulley L2 to the adjustment pulley block (27) using a hex bolt (109) and a self-locking nut (134).
 4. Route the lower cable over pulley L2.
 5. Attach pulley L3 to the main frame (1L) using a hex bolt (109) and a self-locking nut (134).
 6. Route the lower cable over pulley L3.
 7. Attach pulley L4 to the main frame (1L) using a hex bolt (109) and a self-locking nut (134).
 8. Route the lower cable over pulley L4.
 9. Attach pulley L5 to the double pulley block (25) using a hex bolt (109) and a self-locking nut (134).
 10. Route the lower cable over pulley L5.
 11. Connect the lower cable (98) to the bolt end on the main frame (1). (See L6)

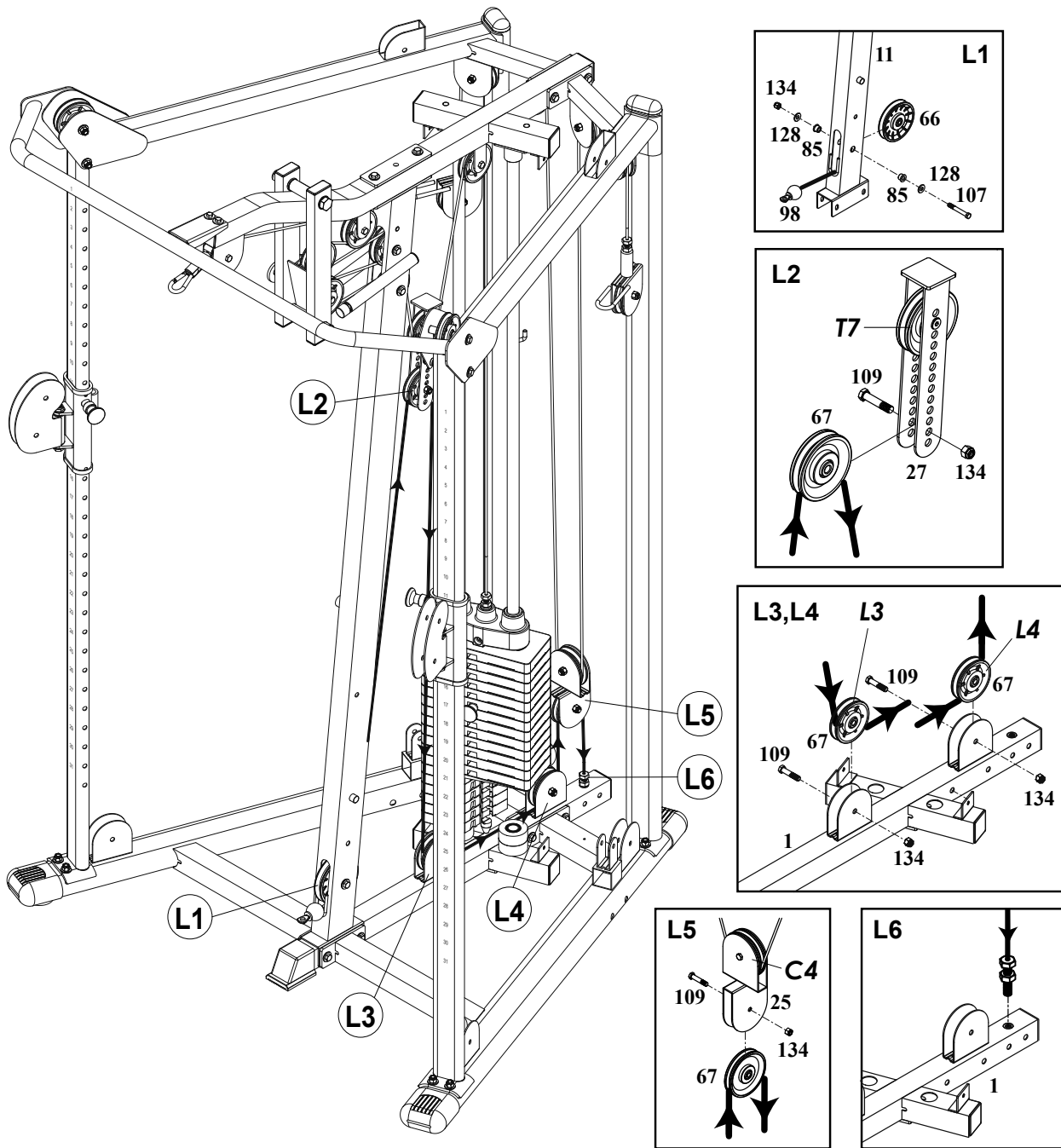
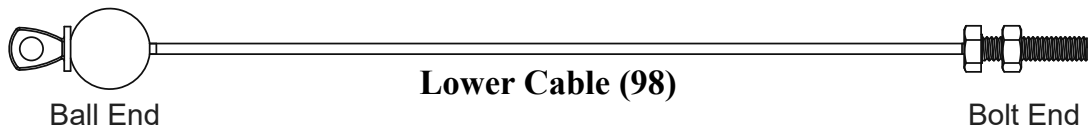

Step 9: Attach the Cable System

ⓘ NOTE

- + Install the cables and pulleys simultaneously.
- + To improve the readability of the instructions, the part number for the pulleys is omitted. The number of the pulleys is (67).

1. Attach the two H1 pulleys to the left pulley height adjuster (23L) using one hex bolt (107) and one self-locking nut (134) for each pulley.
2. Route the ball end of the H/L cable (99) over pulley H1.
3. Attach the two H2 pulleys to the left top frame (6L) and the connector top frame (15) using one hex bolt (103), two washers (128), and one self-locking nut (134).
4. Route the H/L cable (99) over pulley H2.
5. Attach the two H3 pulleys to the left top frame (6L) using one hex bolt (109) and one self-locking nut (134).
6. Route the H/L cable (99) over pulley H3.
7. Attach the two H4 pulleys to the left base frame (3L) using one hex bolt (109) and one self-locking nut (134).
8. Route the H/L cable (99) over pulley H4.
9. Attach the two H5 pulleys to the single pulley block (26) using one hex bolt (109) and one self-locking nut (134).
10. Route the H/L cable (99) over pulley H5.
11. Attach the two H6 pulleys to the left base frame (3L) using one hex bolt (109) and one self-locking nut (134).
12. Route the H/L cable (99) over pulley H6.
13. Attach the two H7 pulleys to the left base frame (3L) using one hex bolt (109) and one self-locking nut (134).
14. Route the H/L cable (99) over pulley H7.
15. Connect the H/L cable (99) to the bolt end on the left pulley height adjuster (23L). (See H8)
16. Tighten the nut halfway.

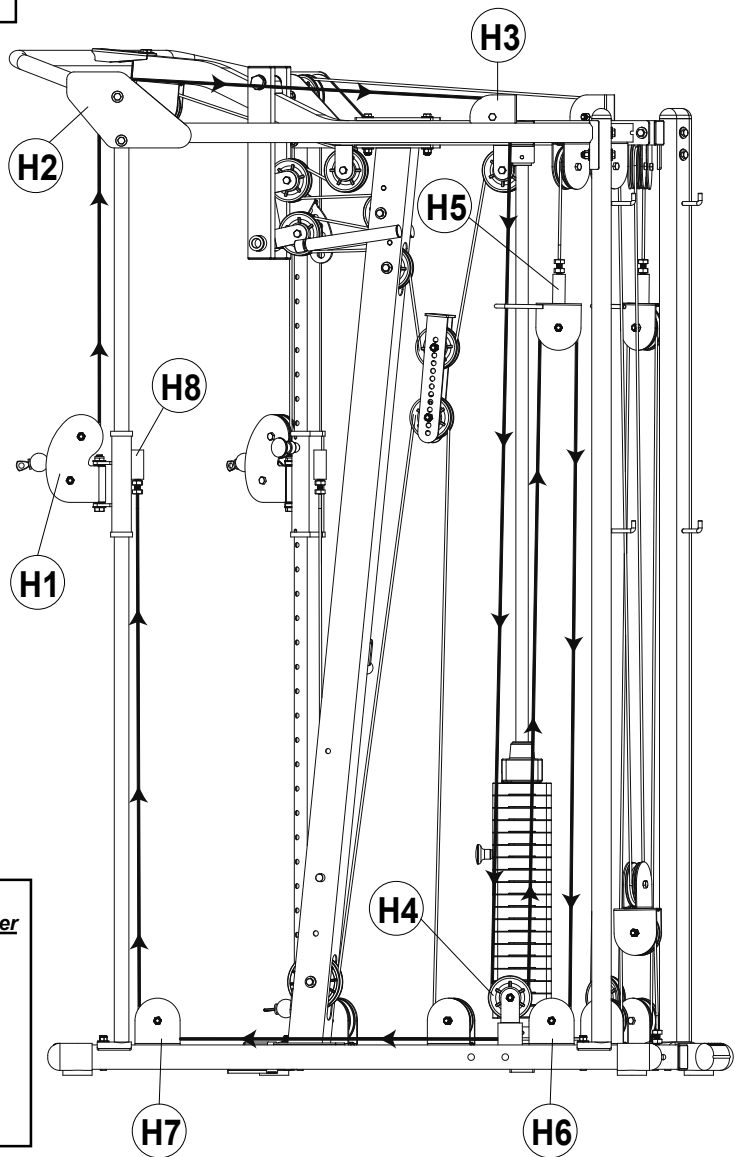
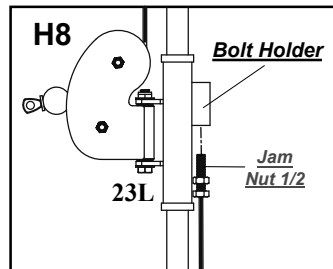
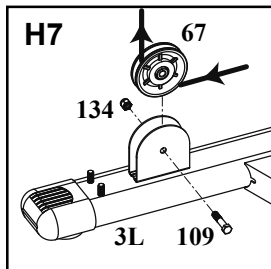
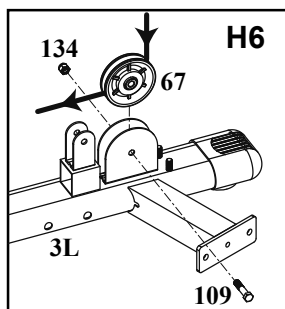
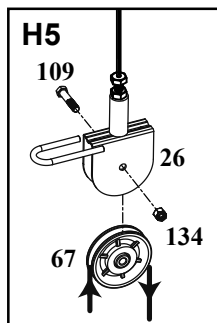
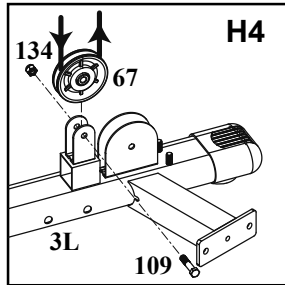
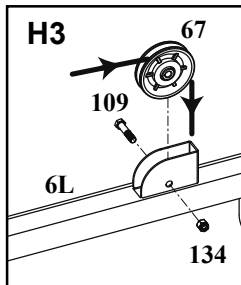
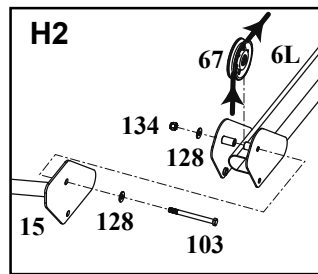
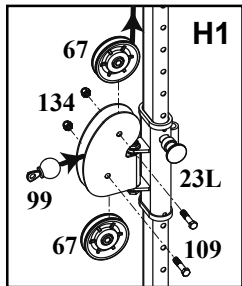
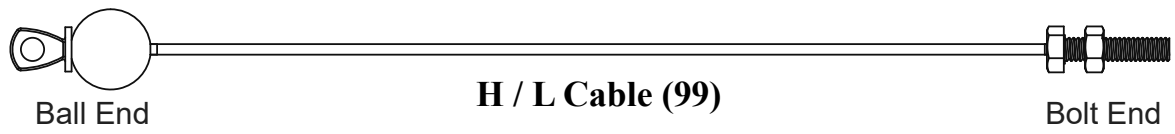

Step 10: Attach the Cable System

1. Attach the seat back adjuster (19) to the support upright frame (11) using one hex bolt (106), two washers (128), and one self-locking nut (134).
2. Initially tighten the bolt and then slightly loosen it if necessary so that the seat back adjuster (19) can move freely.

ⓘ NOTE

The short locking pin (93) should engage in the adjustment holes of the seat back adjuster (19).

3. Attach the leg holder (20) to the seat back adjuster (19) using two screws (117) and two washers (130).
4. Tighten the screws securely.
5. Slide two metal hinges (28) onto the axle welded to the top of the seat back adjuster (19) using the lower holes of the hinges.
6. Attach the back pad (39) to the metal hinges (28) using two threaded bolts (111) and two washers (128) for each hinge.
7. Slide two plastic caps (75) onto the inside ends of the leg holder (20), ensuring that the flat side faces outward.
8. Moisten the foam pads (41) with water and slide them onto the leg holder (20).
9. Place one plastic cap (75 and 76) onto each end and secure them with a round head screw (113) and a washer (129).
10. Tighten the screws securely.

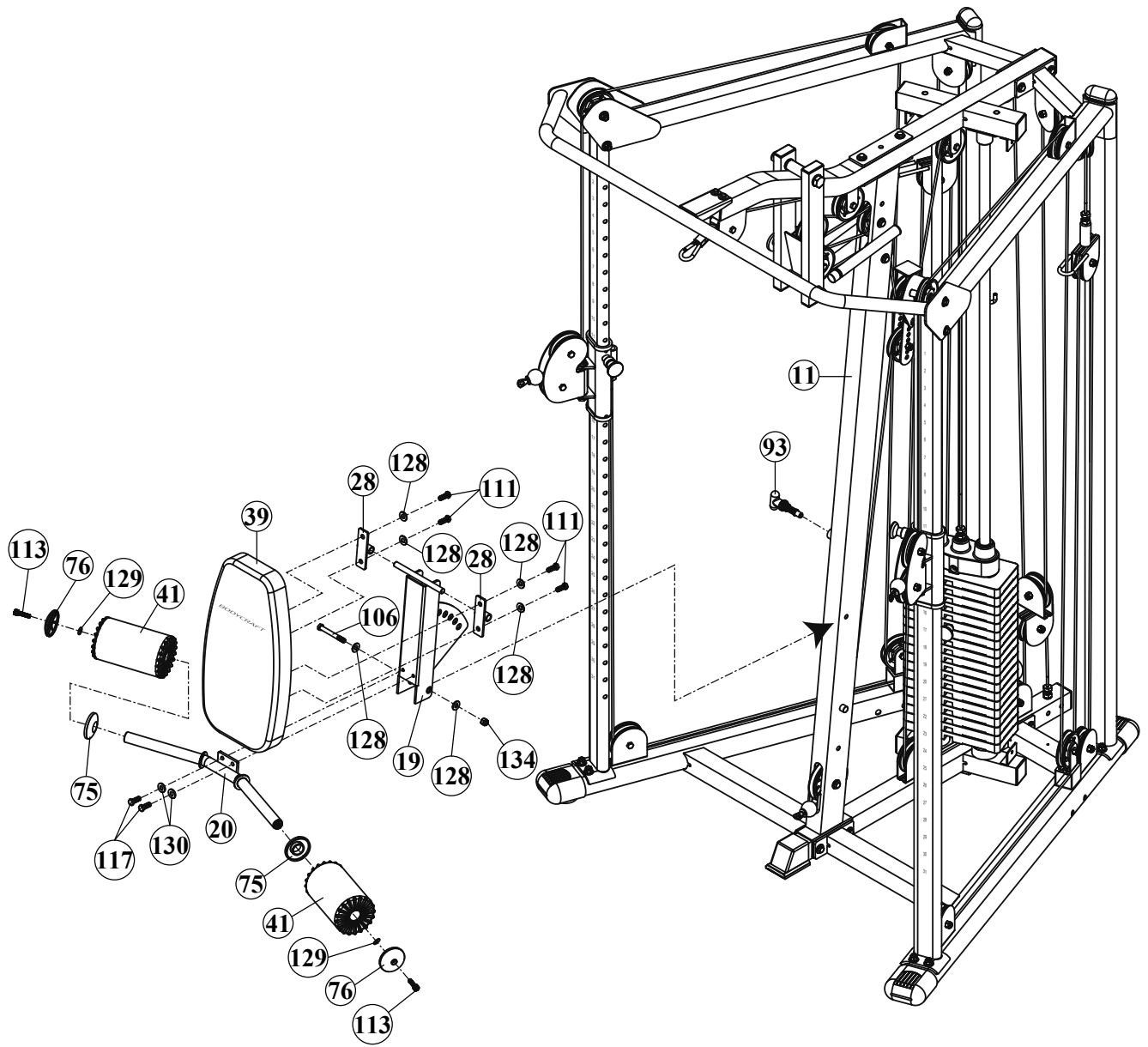

Step 11: Attach the Chest Press

1. Place two oval plugs (139) onto the press arm (14).
2. Attach the press arm (14) to the press arm support (16) by aligning the holes and inserting the press arm axle (37).

► **CAUTION**

Ensure that the longer pop pin (94) is inserted into one of the adjustment holes of the press arm support (16).

3. Secure the press arm axle (37) by tightening the pre-installed hex socket screws (121).
4. Tighten the screws securely.

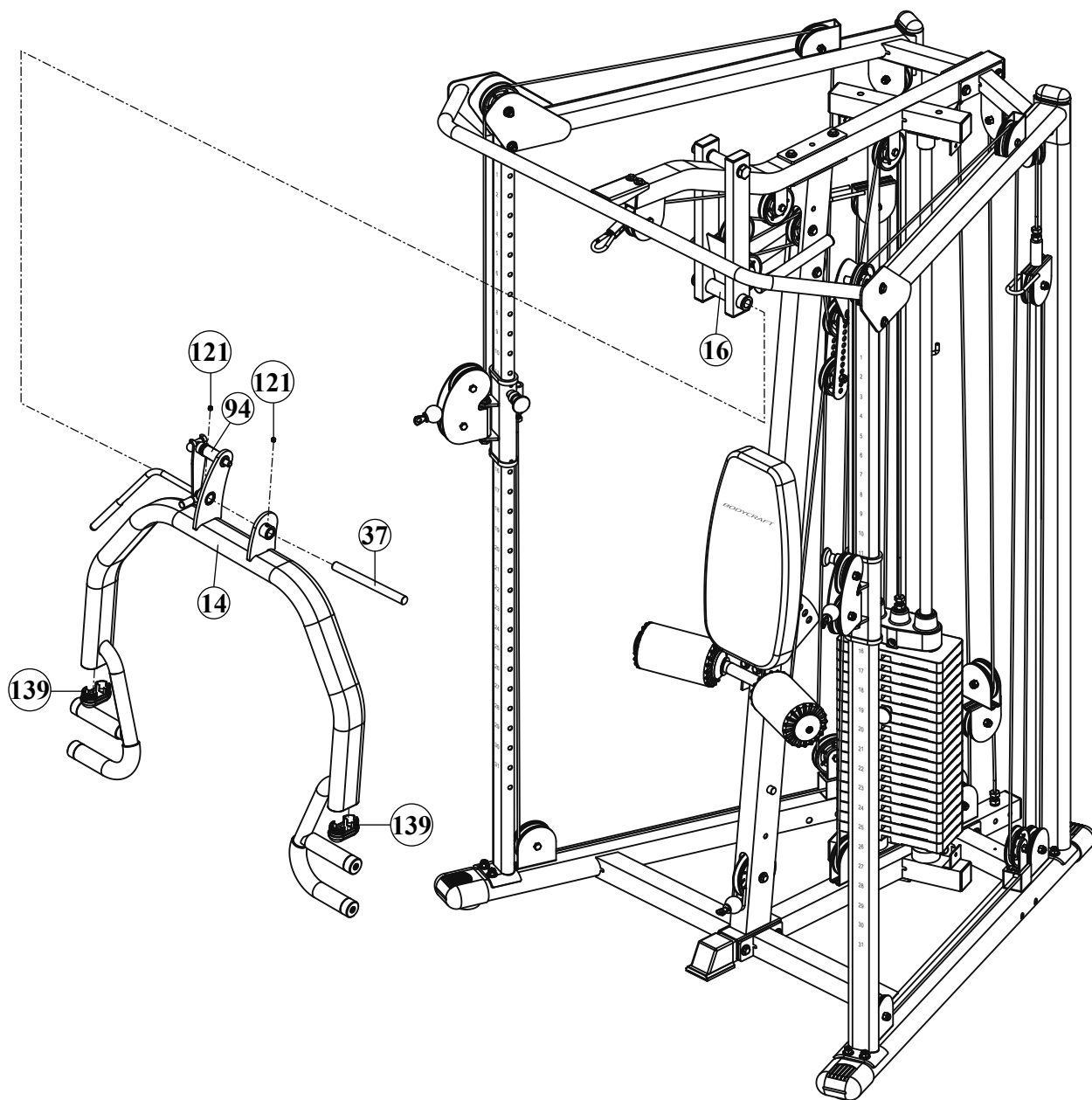

Step 12: Attach the Side Covers

1. Attach the right and left weight shroud (12R, 13L) to the main frame (1) using four round head screws (117) and four washers (130).
2. Tighten all screws, starting with the main frame screws on the base frame and working your way upward.
3. Securely tighten all screws.

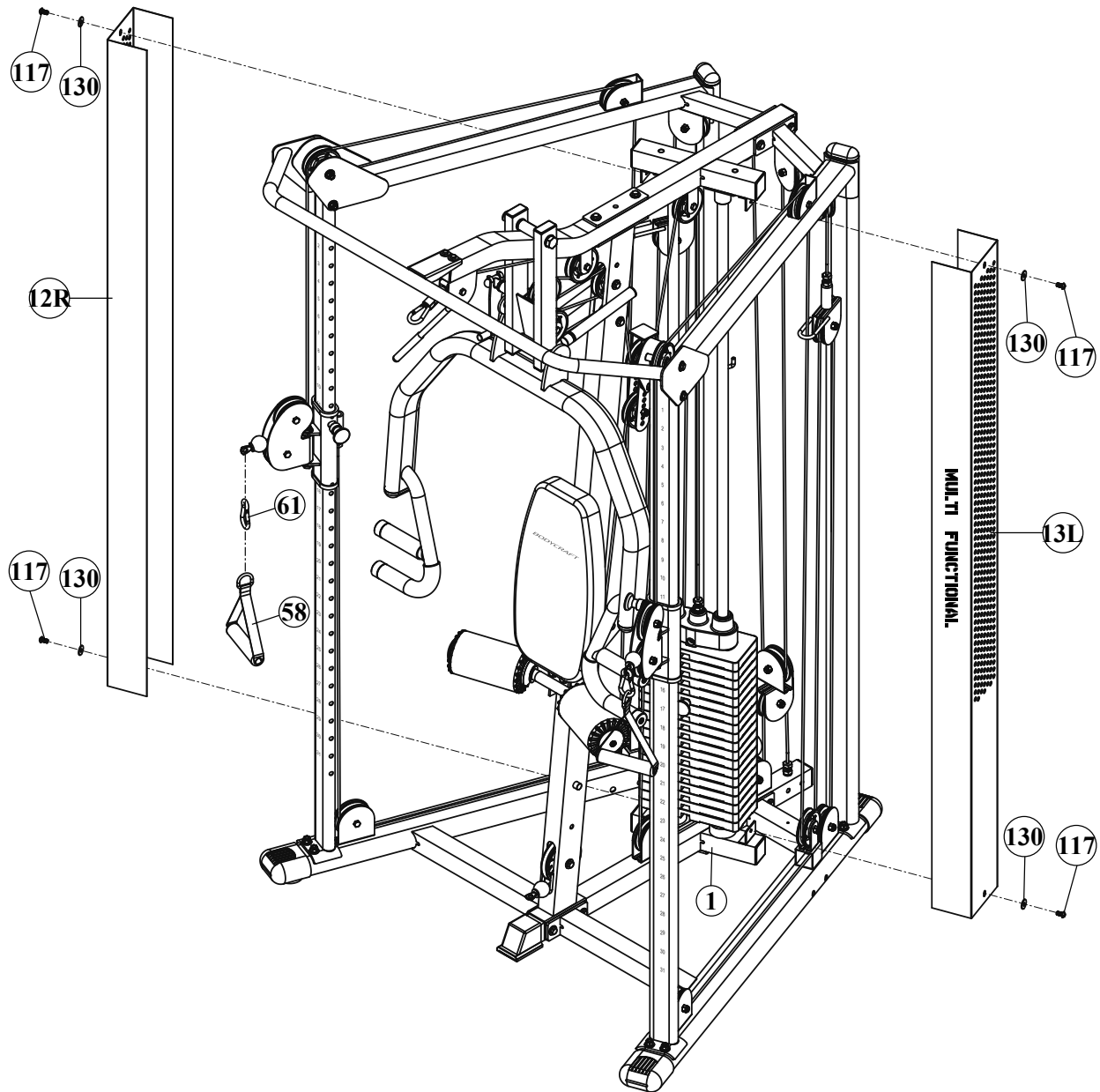

Step 13: Attach the Side Panels

1. Attach the seat frame (17) to the support upright frame (11) by aligning the holes and inserting the selector pin (95).
 2. Attach the seat pad (40) to the seat frame adjuster (18) using two hex bolts (110) and two washers (128).
 3. Insert one end cap (71) into each end of the seat frame adjuster (18).
 4. Place the upper seat frame adjuster (18) into the seat frame (17).
 5. Secure the upper seat frame adjuster (18) with a spring knob (91).
 6. Insert one end plug (70) into the leg extension arm (21).
 7. Attach the leg extension arm (21) to the seat frame (17) by inserting the seat frame axle (38).
 8. Secure the seat frame axle (38) with two round head screws (116), two spring washers (131), and two smaller washers (130).
 9. Insert the foam roller holder (36) into the seat frame (17) and another into the leg extension arm (21), centering both.
 10. Secure the foam roller holder (36) with screws (121, 120).
 11. Slide one plastic cap (75) and one foam pad (41) onto each side of the foam roller holder (36).
 12. Secure the foam pads (41) with one aluminum cap (76), one larger washer (129), and one round head screw (113).
- NOTE**
The washer is placed between the aluminum cap (76) and the foam roller holder (36), as shown.
13. Tighten all remaining screws securely.

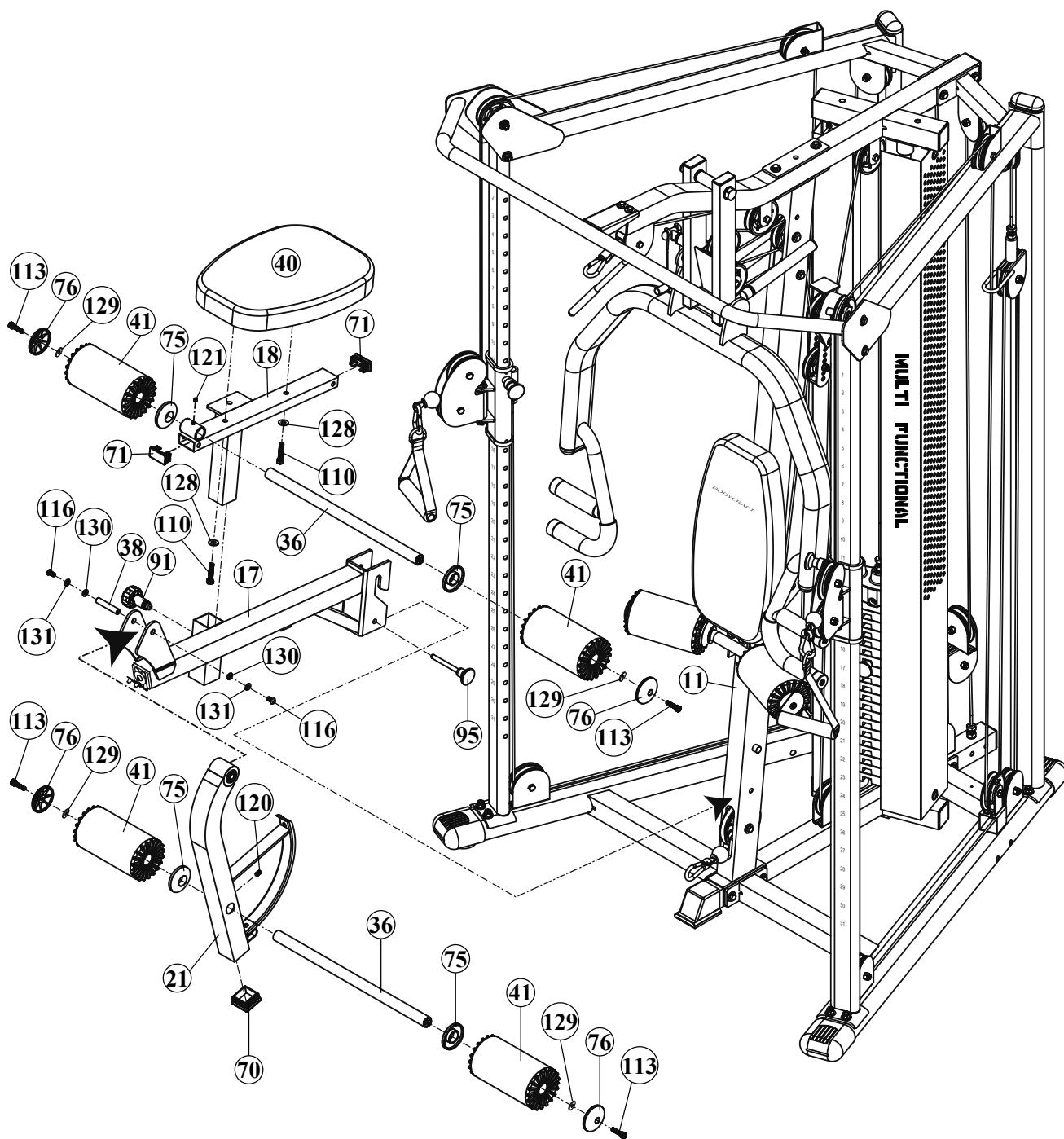

Step 14: Attach the Cable

1. Attach the extension cable (100) to the leg extension arm (21) using a round head screw (114), two washers (128), and a nylon nut (134).

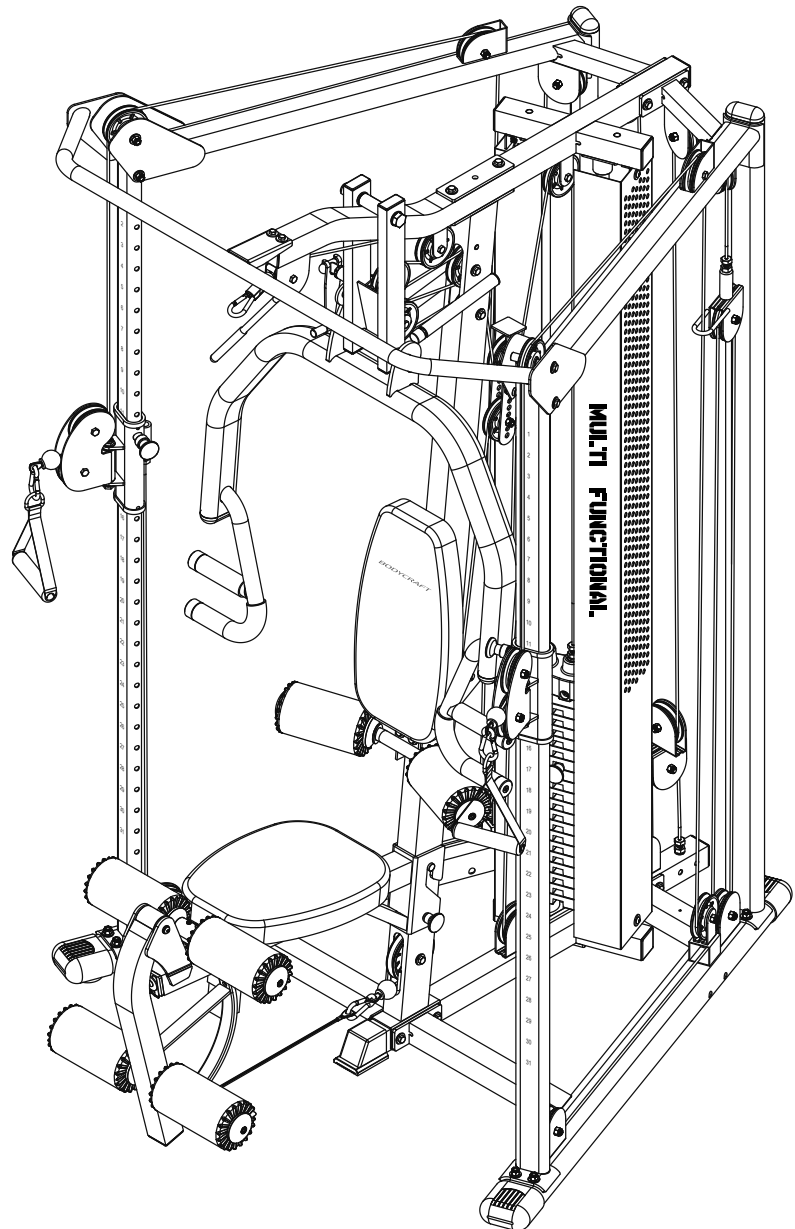
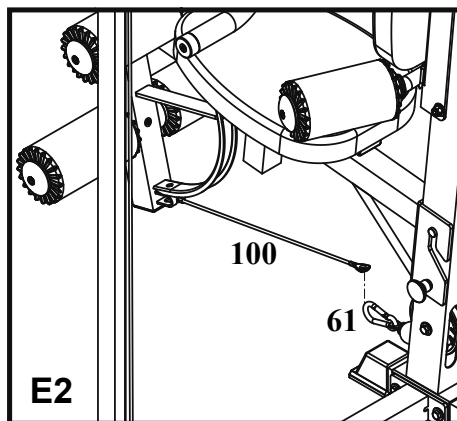
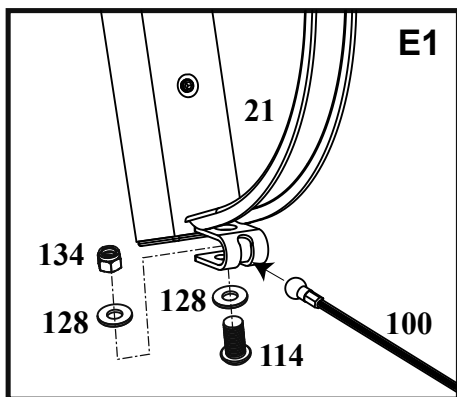
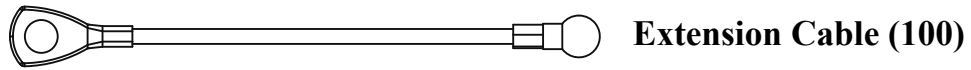

Step 14: Attach the Accessories

1. Attach the lat bar (49) to the top cable (96) as shown.
2. Ensure that all cables are properly seated in the pulley grooves and tighten all screws.
3. Attach the accessories as needed.

→ *The machine is now fully assembled.*

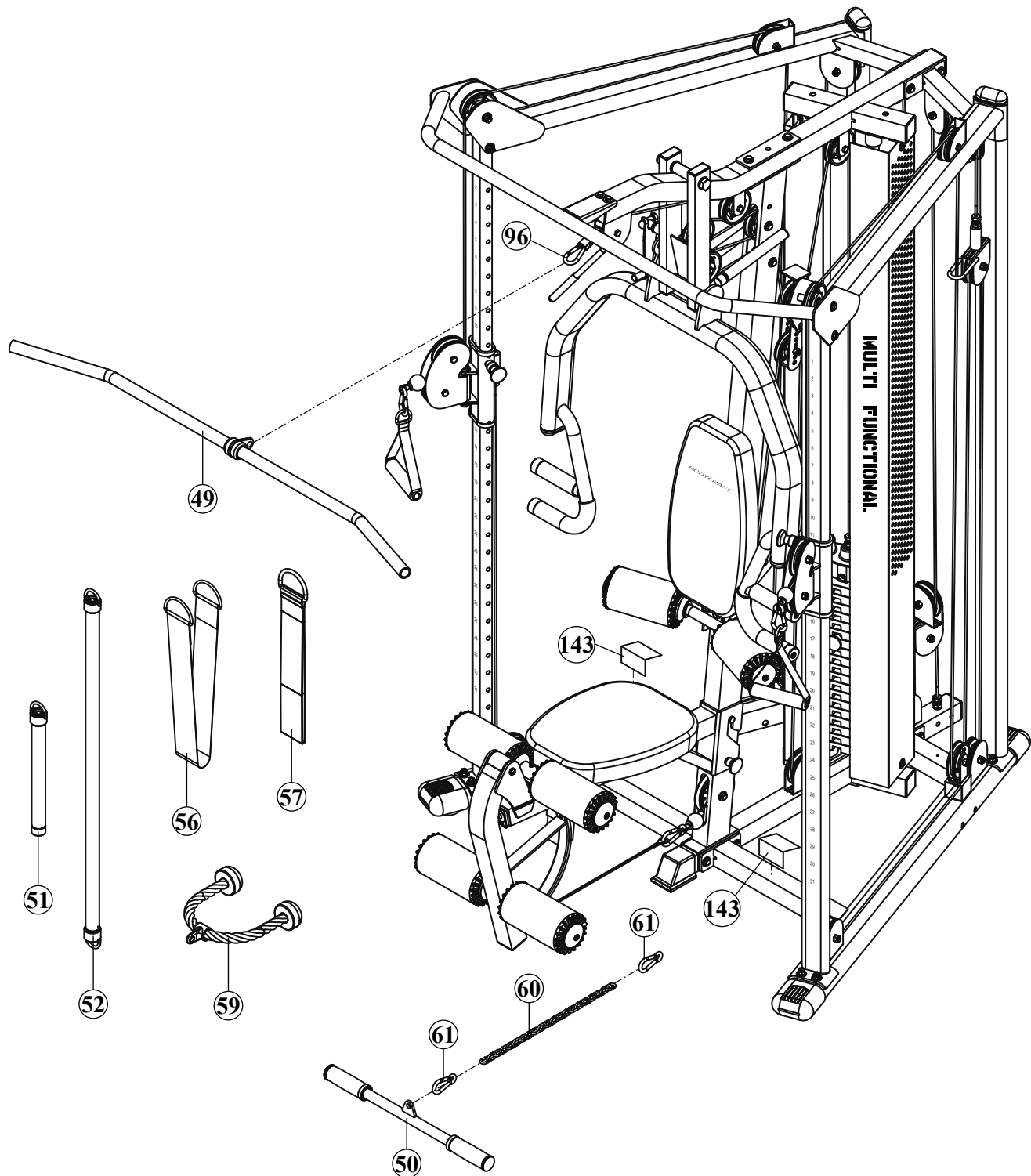

2.4 Set-Up Place

⚠ WARNING

- + Do not place the equipment in main corridors or escape routes.

⚠ CAUTION

- + Choose a location in which to place the equipment such that there is enough free space/clearance to the front, the rear and to the sides of the equipment.
- + The training room should be well ventilated during training and not be exposed to any draughts.
- + Choose the place in which to set up the equipment such that there is enough free space/clearance to the front, the rear and to the sides of the equipment.
- + The free area in the direction from which the exercise equipment is accessed must be at least 0.6 m larger than the exercise area.
- + The set-up and mounting surface of the equipment should be flat, loadable and solid.
- + If your device is to be mounted on the wall/ceiling, make sure that you use the appropriate assembly material to avoid possible damages or personal injuries. The contractual partner accepts no liability for this.

▶ ATTENTION

- + The device may only be used in one building, in sufficiently tempered and dry rooms (ambient temperatures between 10°C and 35°C). The equipment should not be used outdoors or in rooms with high humidity (over 70%) like swimming pools.
- + A floor protective mat/equipment underlay can help to protect high-quality floor coverings (parquet, laminate, cork, carpets) from dents and sweat and can help to level out slight unevenness.
- + For Class S equipment, the exercise equipment may only be used in areas where access, supervision and control are specifically regulated by the owner.

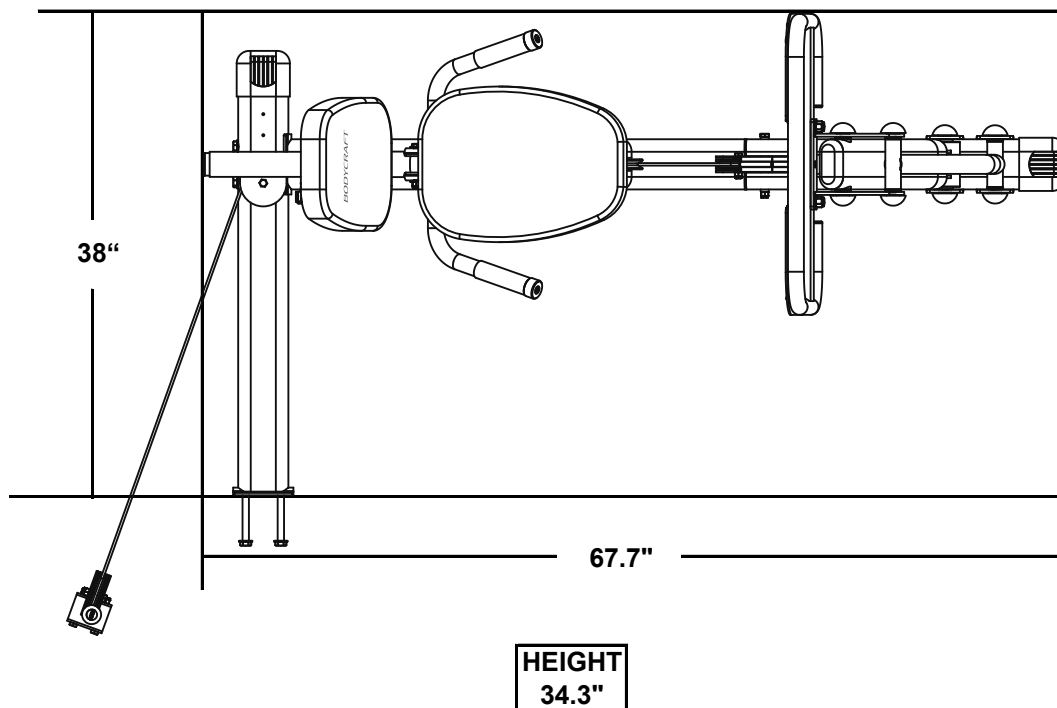

2.5 Scope of Delivery: Leg Press

The scope of delivery consist of the following parts. At the beginning, check whether all parts and tools belonging to the device are included in the scope of delivery and whether damage has occurred. In the event of complaints, the contractual partner must be contacted directly.

CAUTION

If parts of the scope of delivery are missing or damaged, the assembly must not be carried out.

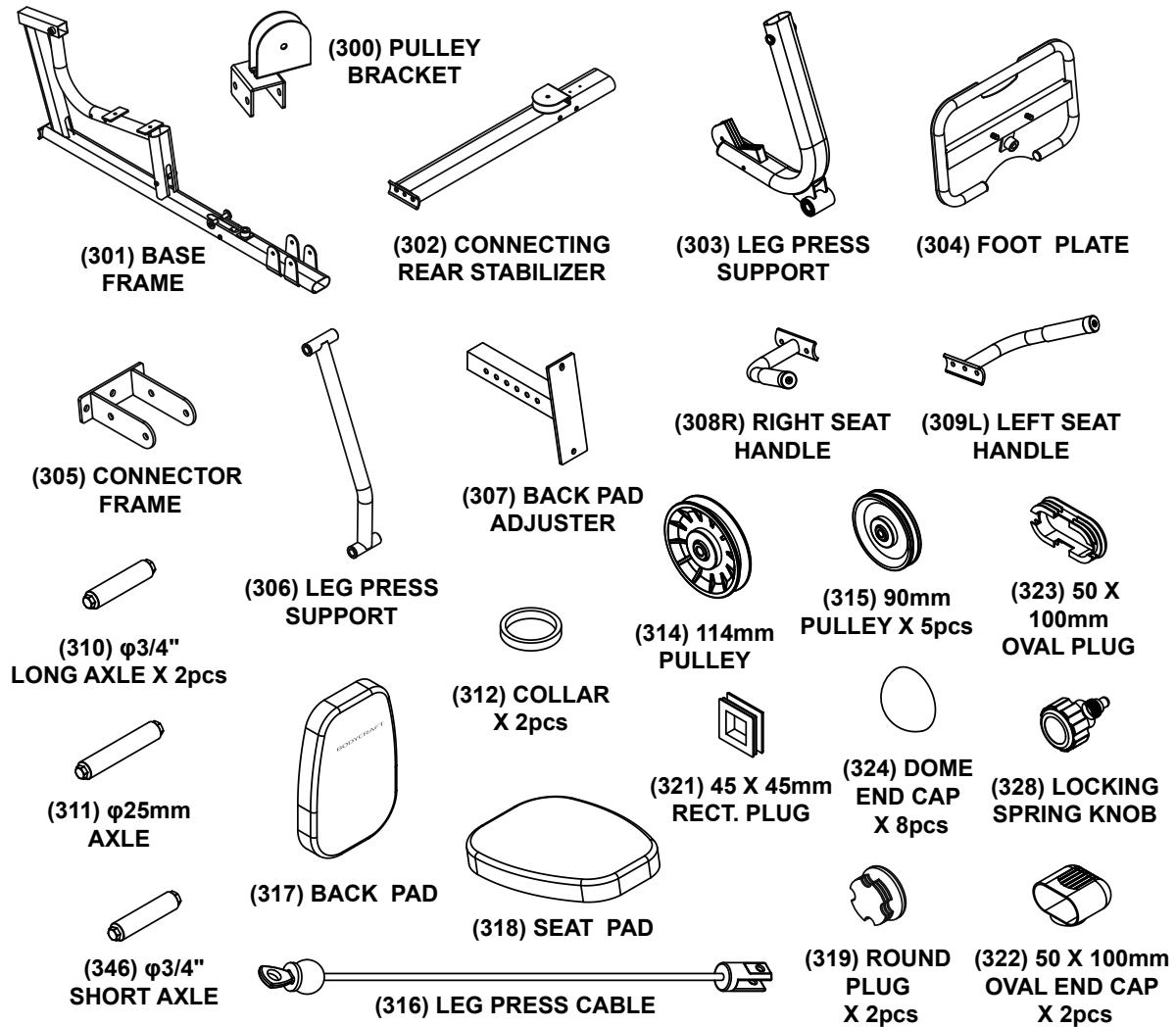

2.6 Assembly: Leg Press

Before assembly, take a close look at the individual assembly steps shown and carry out the assembly in the order given.

ⓘ NOTICE

- + First loosely screw all parts together and check that they fit properly. Tighten the screws using the tool only when you are instructed to do so.
- + Do not tighten the screws and bolts with excessive force as they could be damaged.

Step 1: Begin Assembly

ⓘ NOTE

Before starting the assembly, choose your desired orientation and follow the instructions below.

1. Attach the connecting rear stabilizer (302) to the right (2R) or left base frame (3L) using two hex bolts (329) and two washers (339).
2. Attach the pulley bracket (300) to the main frame (1) using two hex bolts (347), four washers (340), and two nylon nuts (342).

Installation on the Right

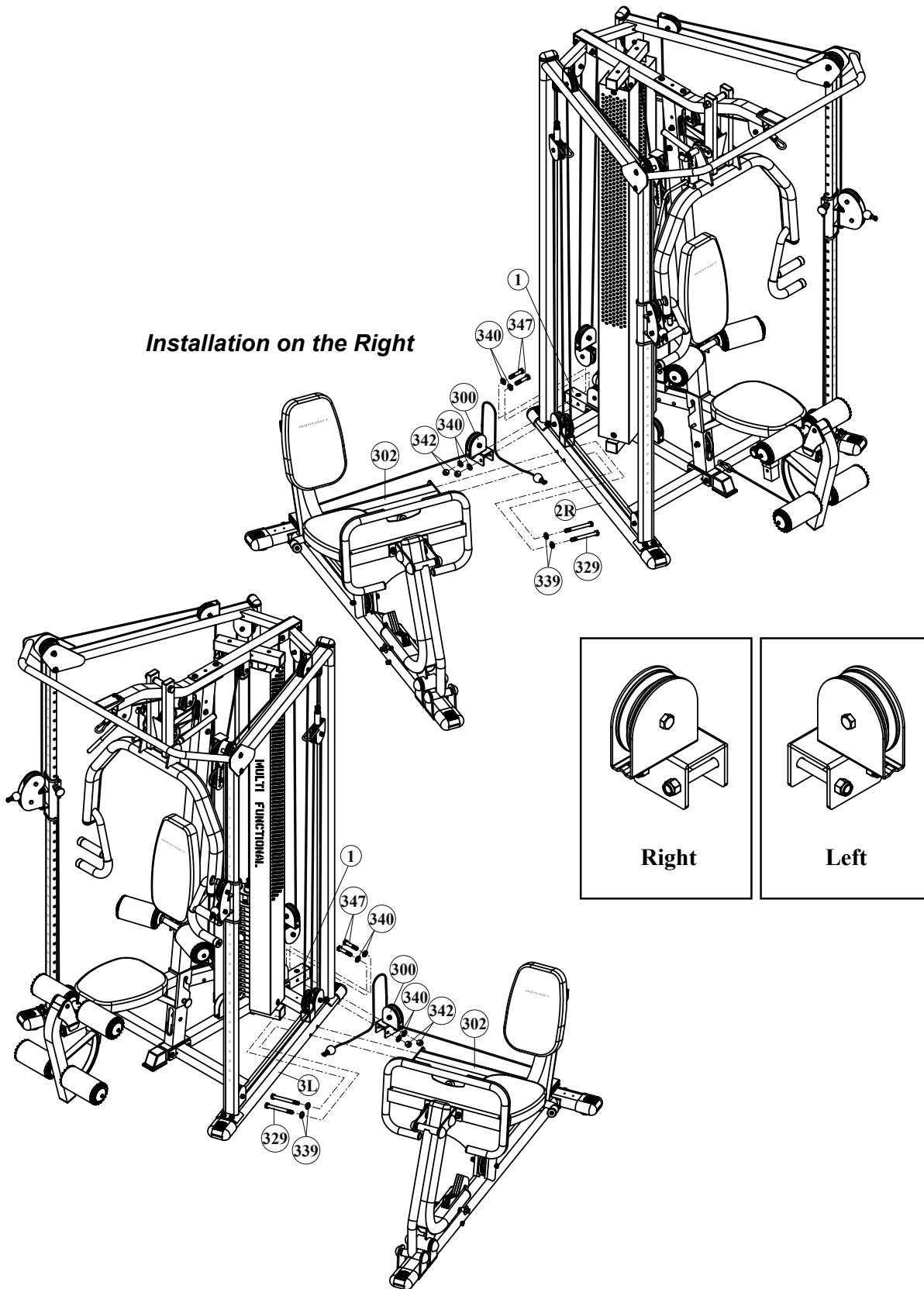

Step 2: Disconnect the Cables

1. Disconnect the extension cable (100).
2. Disconnect the lower cable (98) and the snap hook (61).

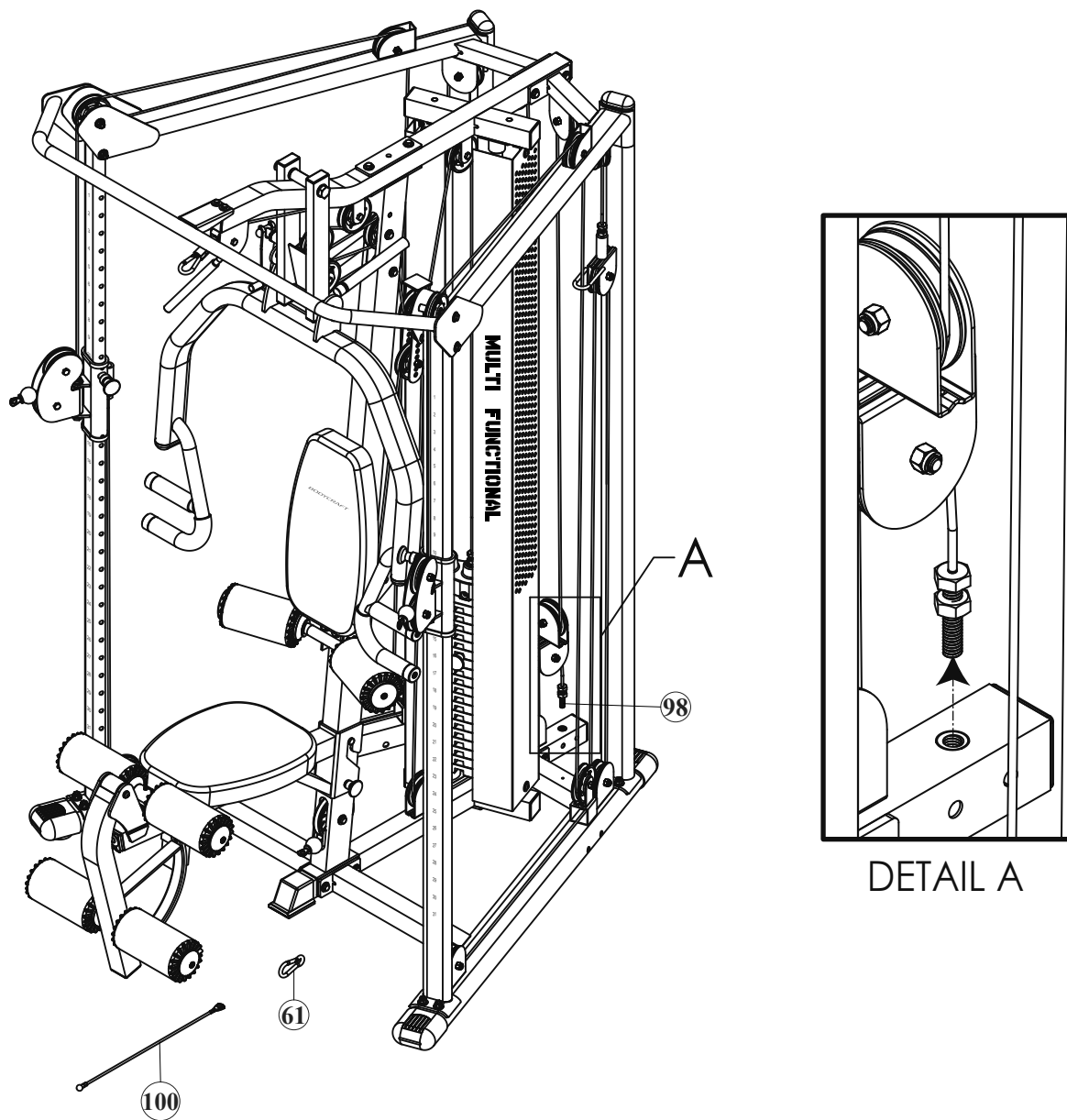

Step 3: Mount the Connection Stabilizer

1. Attach an oval end cap (322) to the connecting rear stabilizer (302).
2. Attach the connecting rear stabilizer (302) to the left base frame (3L) using two hex bolts (329) and two washers (339).
3. Attach the pulley bracket (300) to the main frame (1) using two hex bolts (347), four washers (340), and two nylon nuts (342).

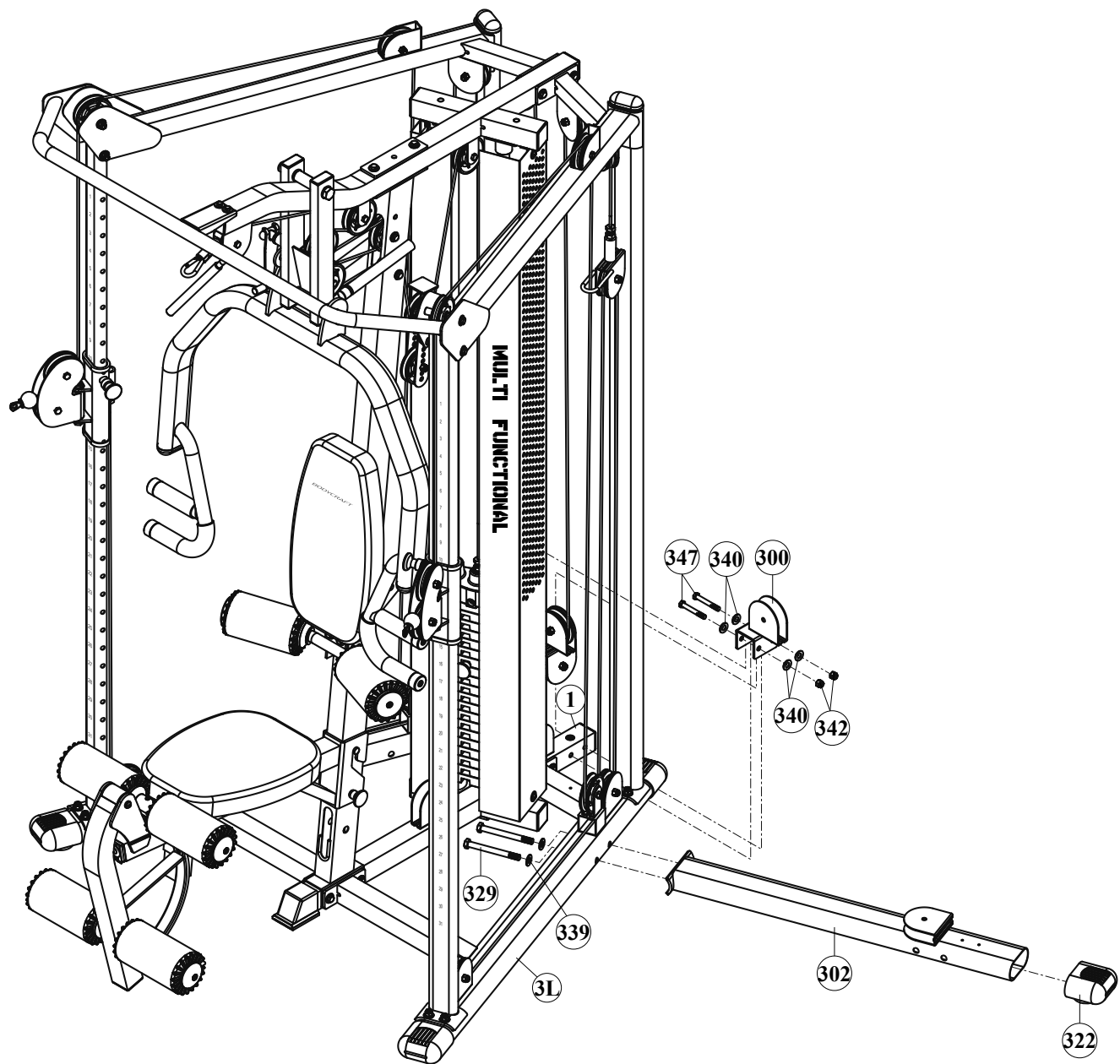

Step 4: Mount the Base Frame

1. Attach an oval plug (323) to the leg press support (303).
2. Insert an oval end cap (322) into the base frame (301).
3. Attach a rectangular plug (321) to the backpad adjuster (307).
4. Attach the base frame (301) to the connecting rear stabilizer (302) with two hex bolts (329) and two washers (339).
5. Insert the axle (311) into the leg press support (303) and secure it to the main frame (301) with two rings (312), two hex bolts (330), and two washers (339).
6. Place two caps (324) onto the bolts (330).
7. Attach the right handgrip (308R) and the left handgrip (309L) to the base frame (301) with two hex bolts (333), four washers (340), and two nylon nuts (342).
8. Attach the seat cushion (318) to the base frame (301) with two hex bolts (334) and two washers (340).
9. Attach the back pad (317) to the back pad adjuster holder (307) with two internal hex bolts (336) and two washers (340).
10. Slide the back pad adjuster (307) into the base frame (301) and lock it in place at the desired position with the locking pin (328).
11. Tighten all screws.

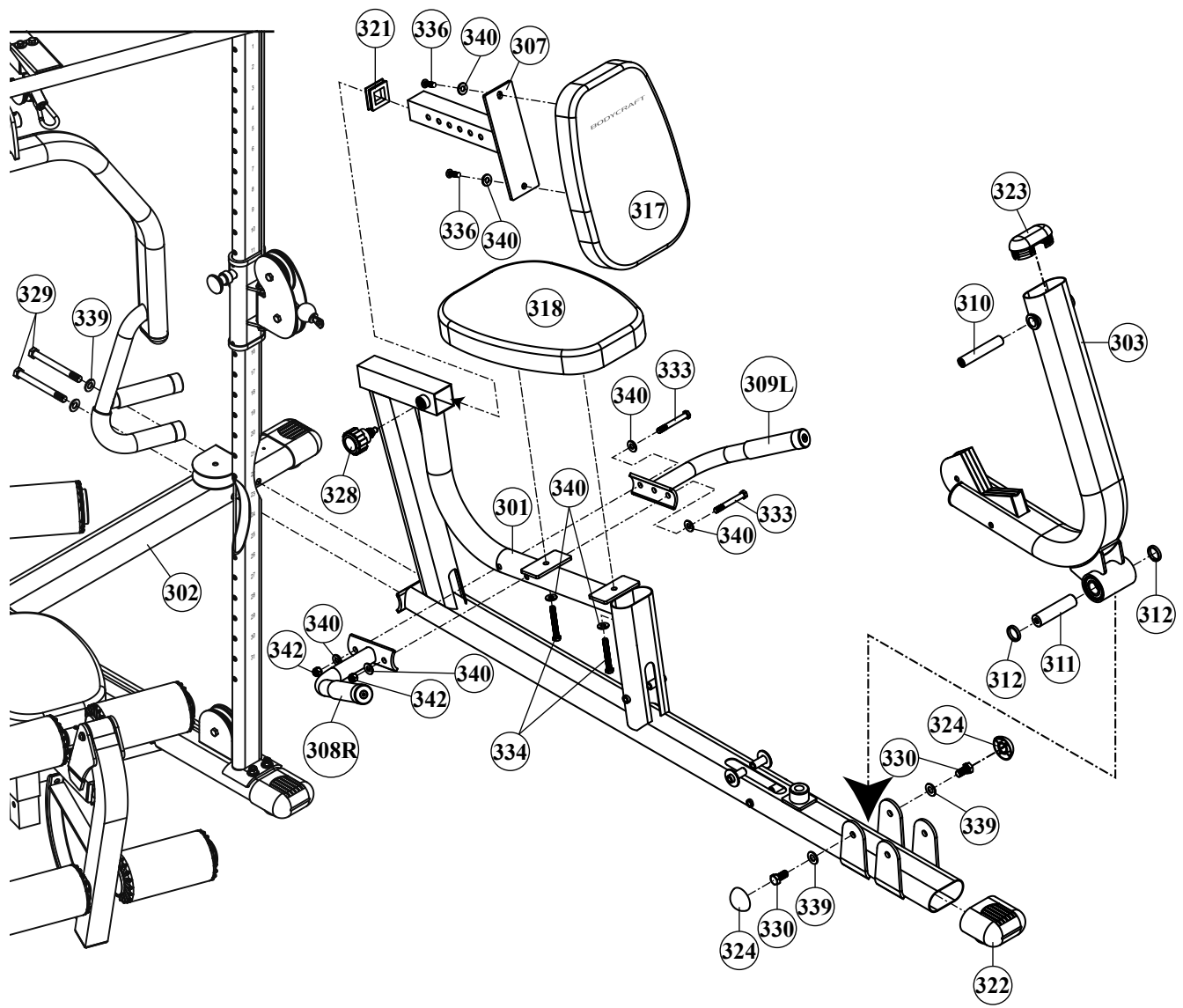

Step 5: Install Cable System

① NOTE

- + Install the cables and pulleys simultaneously.
 - + For better readability of the instructions, the part number for the pulleys is omitted. The part number is (67).
 - + If the lower cable (98) is already installed, it must be removed. This cable will be replaced by the leg press cable (316).
1. Mount pulley (66) on the support upright frame (11) using a hex screw (107), two washers (128), two bushings (85), and a nylon nut (134).
 2. Route the cable around pulley D1.
 3. Mount pulley D2 on the adjustment pulley block (27) using a hex screw (109) and a nylon nut (134).
 4. Route the cable around pulley D2.
 5. Mount pulley D3 on the main frame (1) using a hex screw (109) and a nylon nut (134).
 6. Route the cable around pulley D3.
 7. Mount pulley D4 on the main frame (1) using a hex screw (109) and a nylon nut (134).
 8. Route the cable around pulley D4.
 9. Mount pulley D5 on the double pulley block (25) using a hex screw (109) and a nylon nut (134).
 10. Route the cable around pulley D5.
 11. Mount pulley D6 (315) on the main frame (1) using a hex screw (335) and a nylon nut (342).
 12. Route the cable around pulley D6.
 13. Mount pulley D7 (315) on the connection rear stabilizer (302) using a hex screw (335) and a nylon nut (342).
 14. Route the cable around pulley D7.
 15. Mount pulley D8 (314) on the base frame (301) using a hex screw (331) and a nylon nut (342).
 16. Route the cable around pulley D8.
 17. Mount pulley D9 (315) on the leg press support (303) using a hex screw (335) and a nylon nut (342).
 18. Route the cable around pulley D9.
 19. Mount pulley D10 (315) on the base frame (301) using a hex screw (331) and a nylon nut (342).
 20. Route the cable around pulley D10.
 21. Mount pulley D11 (315) on the leg press support (303) using a hex screw (332) and a nylon nut (342).
 22. Route the cable around pulley D11.
 23. Attach the cable end D12 to the base frame (301) using a hex screw (331) and a nylon nut (342).
 24. Tighten all screws, starting from the connections at the base frame.

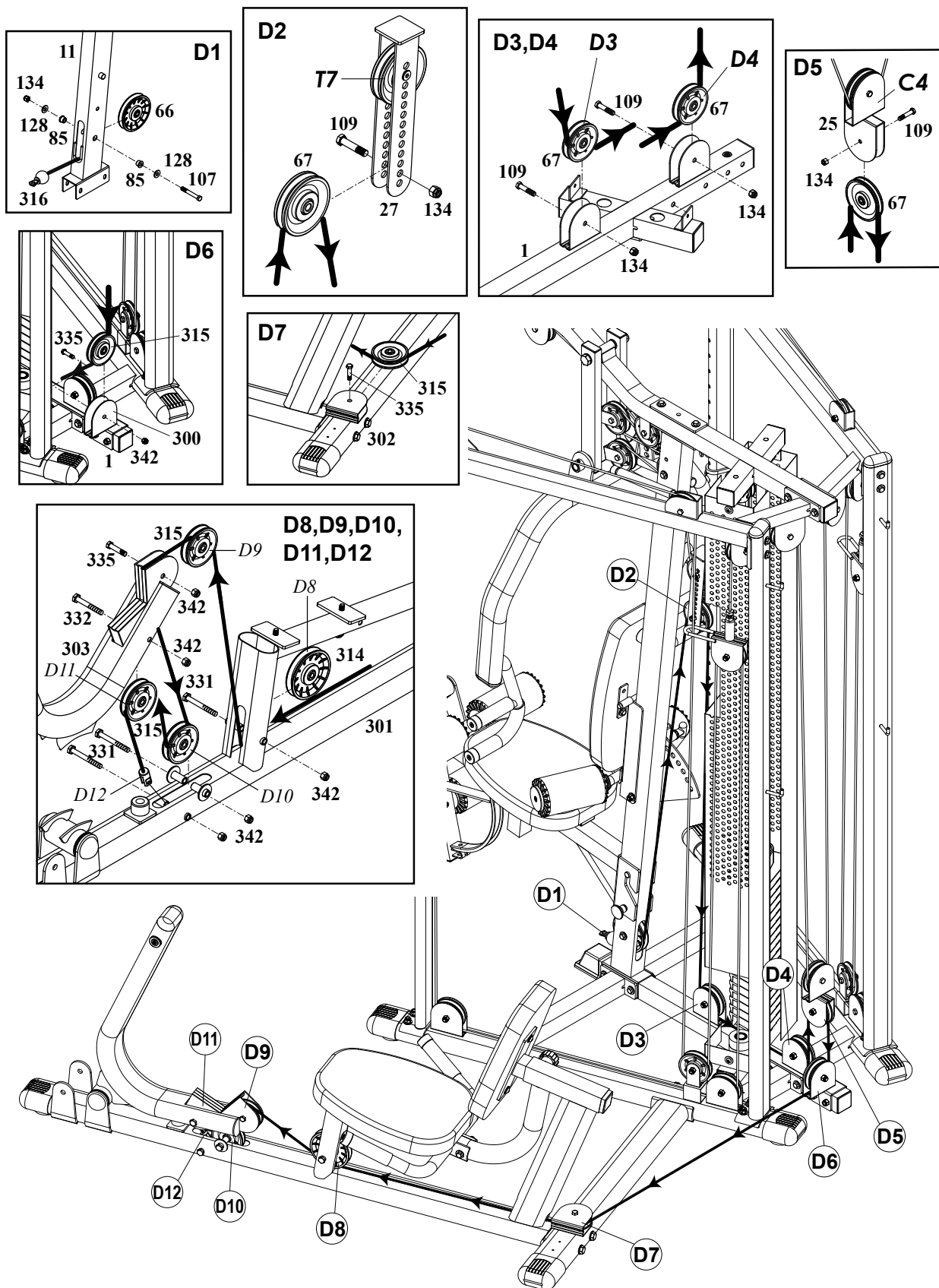

Step 6: Install Extension Cable

1. Attach the extension cable (100) to the leg extension arm (21) using a button screw (114), a washer (128), and a nylon nut (134).

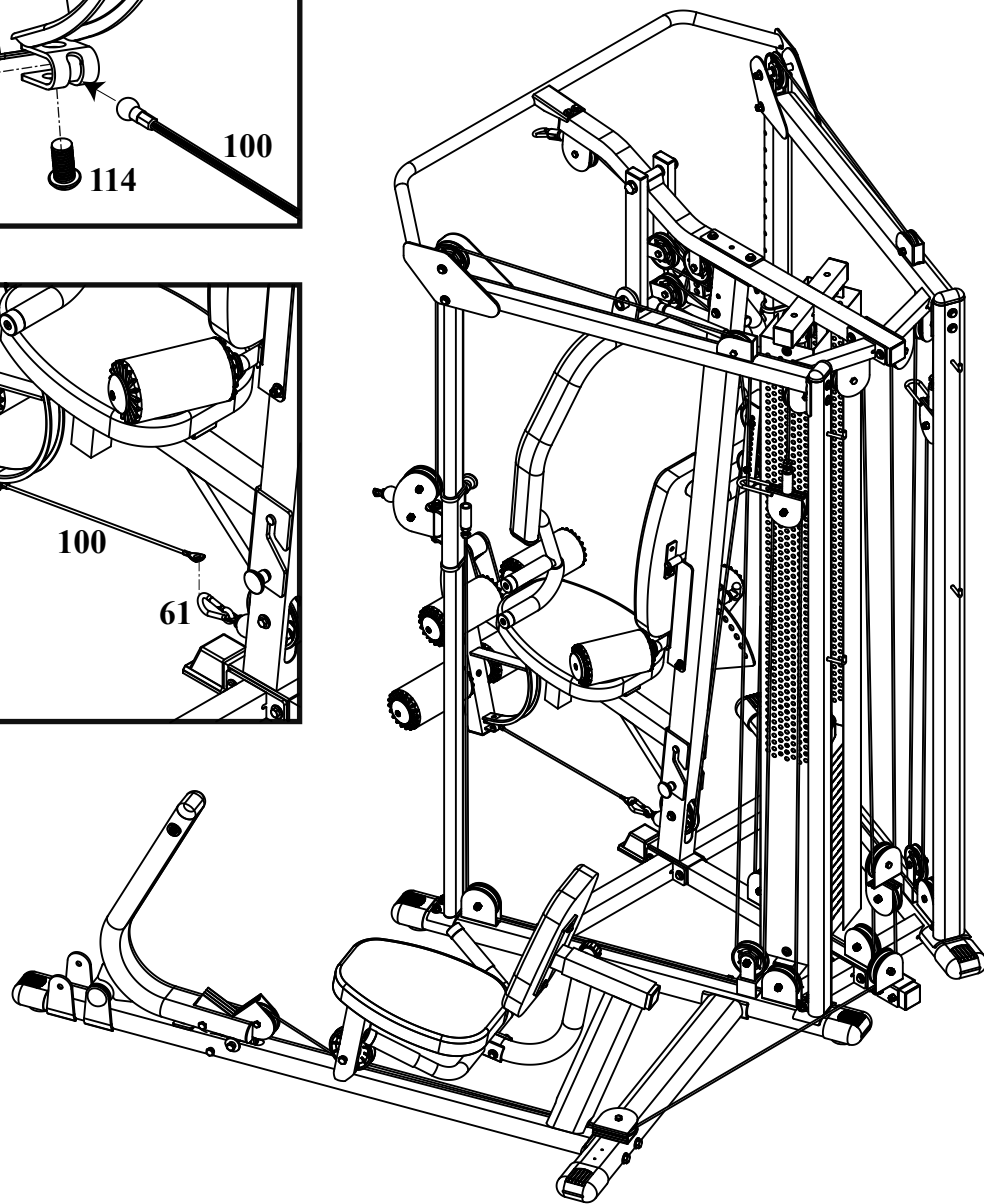
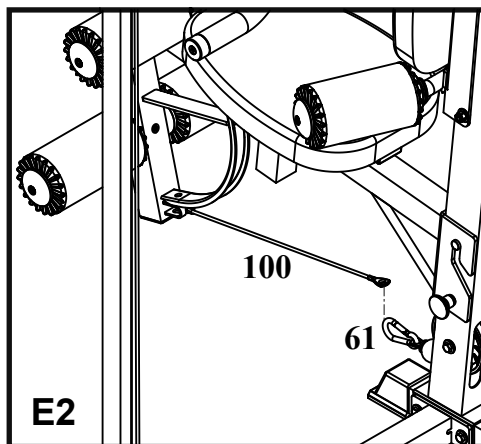
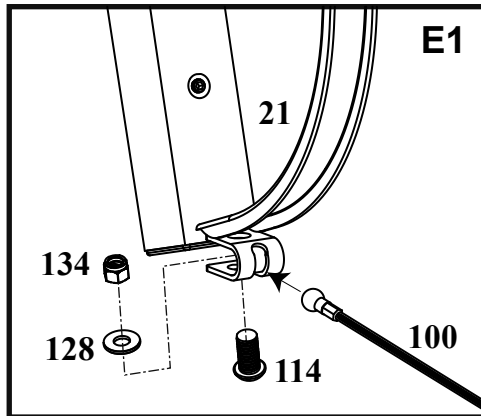

Step 7: Install Foot Plate

1. Insert two round plugs (319) into the foot plate (304).
2. Attach the leg press support (306) to the base frame (301) using a short axle (346), two screws (330), two washers (339), and two end caps (324).
3. Attach the foot plate (304) to the connector frame (305) with two washers (339) and two nylon nuts (341).
4. Attach the connector frame (305) to the leg press support (306) and the leg press support (303) using two long axles (310), four hex screws (330), four washers (339), and four dome end caps (324).
5. Tighten all screws.

→ *The device is now fully assembled.*

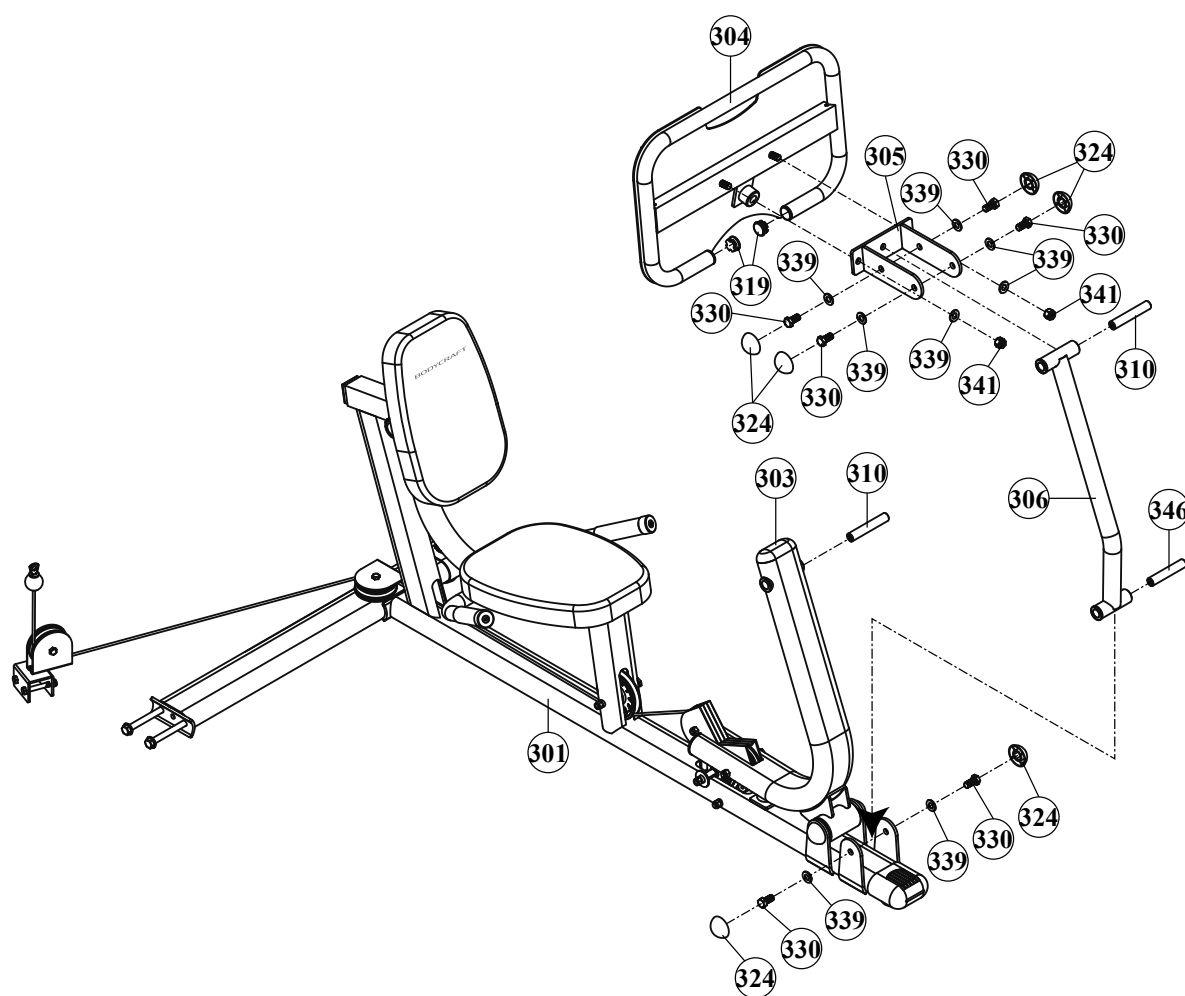

2.7 Assembly: Back Support

Before assembly, take a close look at the individual assembly steps shown and carry out the assembly in the order given.

ⓘ NOTICE

- + First loosely screw all parts together and check that they fit properly. Tighten the screws using the tool only when you are instructed to do so.
- + Do not tighten the screws and bolts with excessive force as they could be damaged.

Step 1: Mount Back Support

1. Place the back support onto the chest press.

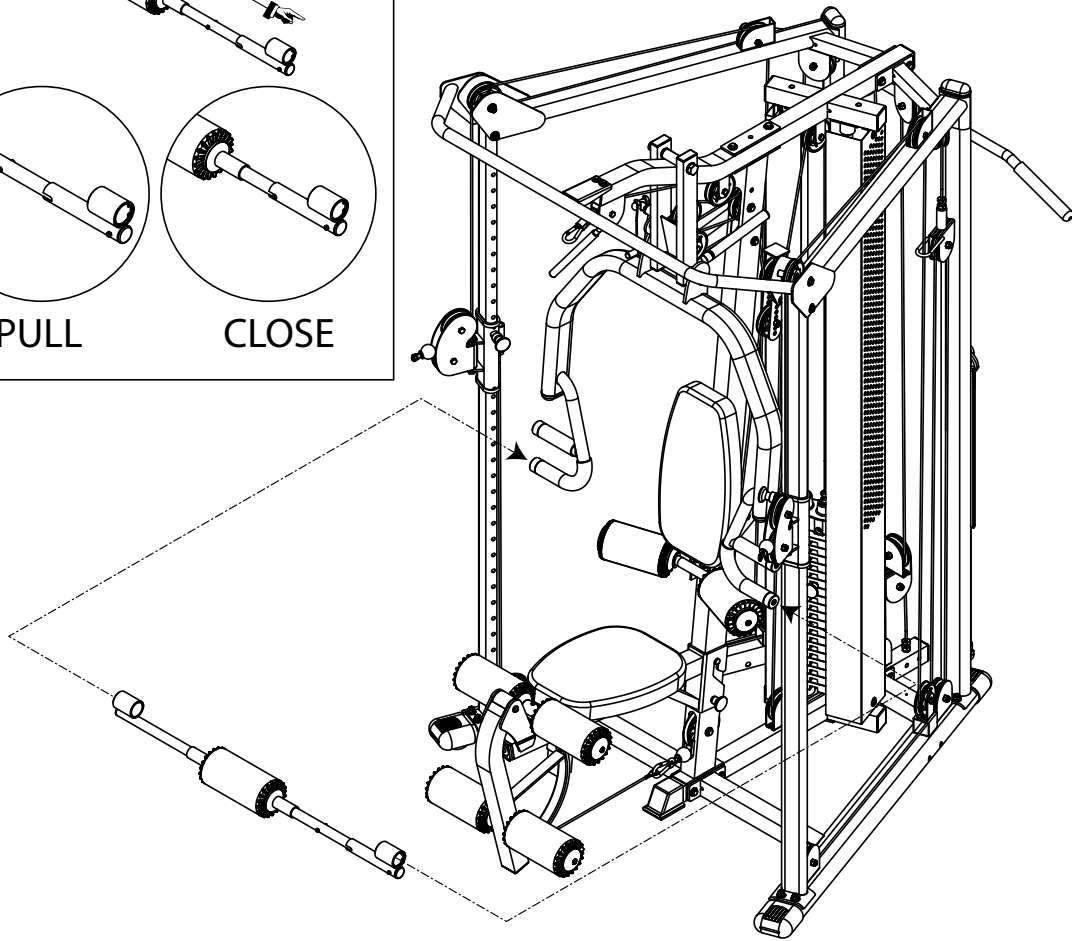
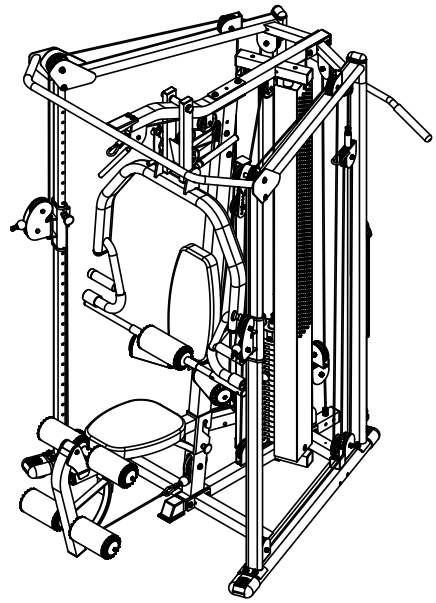
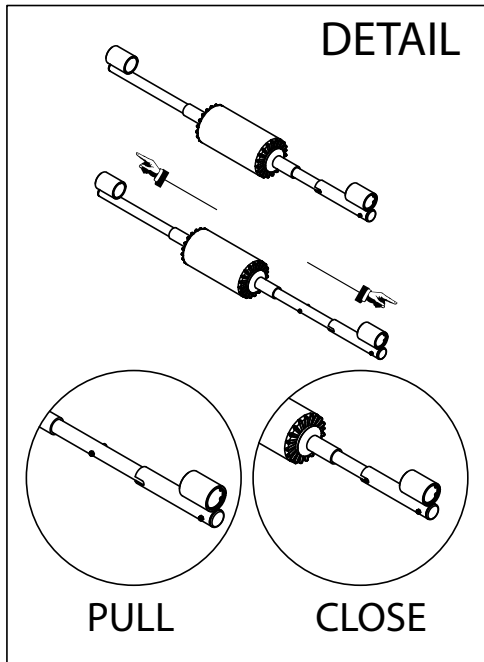

When training, it is important to perform the exercises correctly in order to avoid injuries and achieve the desired training effect. Make sure you use the correct technique and train at an appropriate intensity level. Always consult an expert such as a trainer or doctor if you are unsure or have health problems. Always start your training with a low load and increase it evenly and gently.

End your training with a cool-down phase. If you have any questions or uncertainties, contact your doctor.

3.7.1 Training clothes

During training, wear appropriate sports clothing that is comfortable and breathable. Avoid clothing that restricts you or is uncomfortable. Make sure that your shoes are suitable and offer you sufficient support. In addition, always carry a towel with you to wipe away sweat and keep the equipment clean.

3.7.2 Warming up and stretching

It is important to warm up and stretch properly before training to avoid injury and improve performance. Stretching helps to loosen muscles and improve flexibility. Be sure to incorporate a short stretching routine before each workout.

Warm-up exercise:

1. Stand upright with your feet about shoulder-width apart.
2. Start with gentle arm circles by slowly moving your arms forwards in small circles in a controlled manner.
3. Perform arm circles backwards to loosen your shoulders and arms.
4. Do squats by slowly squatting down and then straightening up again. Make sure that your knees do not extend beyond your toes.

CAUTION

Do not exercise with sore muscles or take it easy on the affected muscles, as this can lead to injuries.

3.7.3 Medication

If you regularly take medication and want to exercise, it is important to be aware of possible side effects. Ask your doctor whether your medication affects your workout.

3.7.4 Used muscle groups

This training can use the following muscle groups:

- + Gluteal muscle
- + Leg muscles
- + Arm muscles
- + Pectoral muscles
- + Back muscles

Make sure you keep your back straight during training. Do not hunch over and do not arch your back. Do not fully extend your legs, but keep a slight bend in the backwards movement.

3.7.5 Exercise frequency

Regular exercise is crucial to making progress and staying healthy in the long term. Continuous exercise can strengthen muscles, improve endurance and enhance overall well-being. Remember that even small workouts can be done regularly to achieve long-term results.

Training with heart rate orientation

Heart rate orientation guarantees an extremely effective and healthy training. Through your age and the following table, you can quickly and easily read and determine the optimal pulse for your training. An acoustic alarm will sound if your heart rate exceeds the set target heart rate. Which target heart rate is important for which training goal can be found out in the following.

Fat burning (weight management): The main goal here is to burn deposits of fat. In order to achieve this training goal, a low training intensity (approximately 55% of the maximum heart rate) and a longer training period are required.

Cardiovascular training (cardio training): The primary goal is to increase stamina and fitness through an improved provision of oxygen through the cardiovascular system. In order to achieve this training goal, medium intensity (approximately 75% of the maximum heart rate) with a medium training period is required.

Anaerobic (maximum) load training: The main goal of maximum load training is to improve recovery after short, intense loads in order to be able to quickly return to the aerobic zone. In order to achieve this training goal, a high intensity (approximately 90% of the maximum heart rate) with short, intense load is required, which is followed by a recovery phase in order to prevent muscle fatigue.

Example:

For a 45-year-old man, the maximum heart rate is 175 ($220 - 45 = 175$).

- + The fat burning target zone (55%) is at approximately 96 beats/min. = $(220 - \text{age}) \times 0.55$.
- + The cardio target zone (75%) is at approximately 131 beats/min. = $(220 - \text{age}) \times 0.75$.
- + The maximum heart rate for an anaerobic load training (90%) is at approximately 157 beats/min. = $(220 - \text{age}) \times 0.9$.

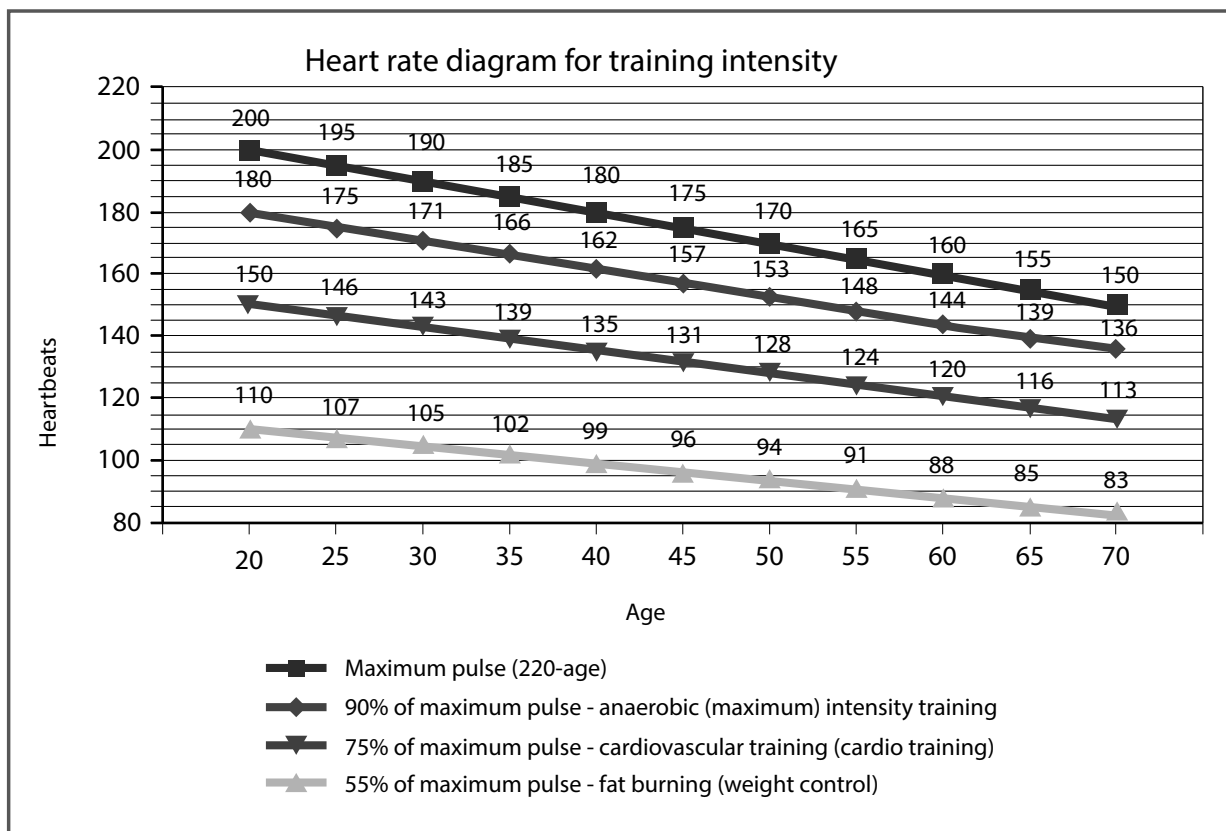

4.1 General Instructions

WARNING

- + The storage location should be chosen so that improper use by third parties or children can be prevented.
- + If your equipment does not have transportation wheels, the equipment must be disassembled before transportation.

ATTENTION

- + Make sure that the equipment is protected from moisture, dust and dirt in the selected storage location. The storage location should be dry and well ventilated and have a constant ambient temperature between 10°C and 35°C.

4.2 Transportation Wheels

ATTENTION

If you want to transport your equipment over particularly sensitive and soft floor coverings, such as parquet, planks or laminate, lay out the transport route with cardboard or similar to avoid possible floor damage.

1. Stand behind the equipment and lift it until the weight is transferred to the transportation wheels. After that, you easily can move the equipment to a new position. For long transport distances the equipment should be disassembled and safely packed.
2. Select the new location by following the instructions in the section 1.4 of this manual.

5.1 General Instructions

⚠ WARNING

- + Do not make any improper changes to the equipment.

⚠ CAUTION

- + Damaged or worn components may affect your safety and the life of the equipment. Therefore, immediately replace damaged or worn components. In such a case, contact the contract partner. The equipment must not be used until it has been repaired. If necessary, use only original spare parts.

▶ ATTENTION

- + In addition to the instructions and recommendations for maintenance and care given here, additional service and/or repair work may be necessary; this must only be carried out by authorised service technicians.

5.2 Faults and Fault Diagnosis

The equipment undergoes regular quality controls during production. Nevertheless, faults or malfunctions may occur. Frequently, individual parts are responsible for these disturbances, an exchange is usually sufficient. Please refer to the following overview for the most common errors and how to correct them. If the equipment still does not function properly, contact your contract partner.

Fault	Cause	Solution
Grinding noises	Cables or pulleys do not run smoothly or are damaged	+ Visual inspection of the cable routing or the pulley guide + If damaged, replace the defective part
Weight hanging in the air	Cable tensioned too tight	Readjust cable tension
Cable without tension	Cable too loose	+ Check cable routing + Readjust cable tension
Squeaking & cracking noises	Screw connections loosened or too tight	+ Check or lubricate screw connections* + Check cable routing
Unit wobbles	+ Uneven ground + Loose screw connections	+ Align unit + Tighten screw connections
Heavy draught	+ Weight holders/guide rods too dry + Faulty cable routing	+ Lubricate guide rods* + Check cable routing

* With a grease-free silicone oil or silicone spray.

5.3 Maintenance and Inspection Calendar

To avoid damage from body sweat, the equipment must be cleaned with a damp towel (no solvents!) after each training session.

The following routine tasks must be performed at the specified intervals:

Part	Weekly	Monthly	Quarterly
Cables	C	I	
Screw connections		I	
Pulleys and cable routing		I	
Slide rails/Guide rods		I	
Cushions	C		
Legend: C = clean; I = inspect			

6 DISPOSAL

At the end of its operational life, this equipment cannot be disposed of in normal household waste. Instead, it must be disposed of via a recycling centre. Further information can be obtained from your local authority's recycling service.

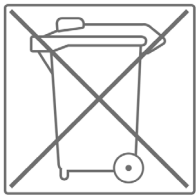

The materials can be recycled as per their symbols. Through the reuse, recycling of materials or other forms of recovery of old equipment, you make an important contribution to the protection of the environment.

7 RECOMMENDED ACCESSORIES

To make your training experience even more efficient and pleasant, we recommend that you add suiting accessories to your fitness equipment. For training equipment like smith machines, weight benches or racks this could for example be a **floor mat**, which makes your fitness equipment stand more securely and also protects the floor from sweat but it could be also **additional weights, handles, foot straps** for leg exercises or **triceps ropes**. For some smith machines, there are also optional add-ons such as **leg presses** that make your workout even more intense and comprehensive.

Our range of accessories offers the highest quality and makes training even better. If you would like to find out more about compatible accessories, please go to the detail page of the product in our webshop (the easiest way is to enter the article number in the search field above) and go to the recommended accessories on this page. Of course, you can also contact our customer service: by telephone, e-mail, in one of our branches or via our social media channels. We will be happy to advise you!



floor mat



chest strap



tricep and curl bar



triceps rope

8.1 Serial Number and Model Name

In order to provide you with the best possible service, please have the model name, article number, serial number, exploded drawing and parts list ready. The corresponding contact options can be found in chapter 10 of this operating manual.

NOTICE

The serial number of your equipment is unique. It's located on a white sticker. The exact position of this sticker is shown in the following illustration.

Enter the serial number in the appropriate field.

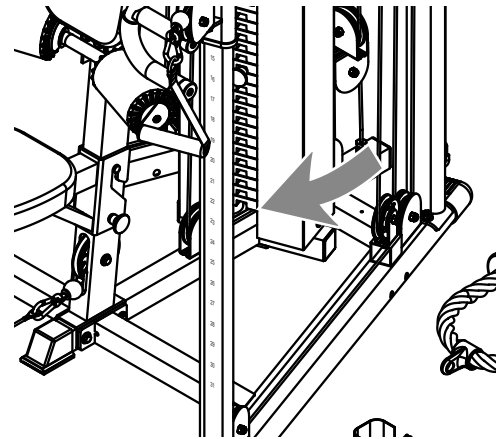

Serial number:

Brand / Category:

BodyCraft / multi gym

Model Name:

MFT

Leg Press

Back Support

SKU:

BC-MFT

BC-LP

BACK SUPPORT

8.2 Parts List: MFT

No.	Name	Qty.
1L	MAIN FRAME	1
2R	RIGHT BASE FRAME	1
3L	LEFT BASE FRAME	1
4	TOP FRAME	1
5R	RIGHT TOP FRAME	1
6L	LEFT TOP FRAME	1
7	VERTICAL GUIDE ROD	2
8R	RIGHT UPRIGHT FRAME	1
9L	LEFT UPRIGHT FRAME	1
10	REAR UPRIGHT FRAME	2
11	SUPPORT UPRIGHT FRAME	1
12R	RIGHT WEIGHT SHROUD	1
13L	LEFT WEIGHT SHROUD	1
14	PRESS ARM	1
15	CONNECTOR TOP FRAME	1
16	PRESS ARM SUPPORT	1
17	SEAT FRAME	1
18	SEAT FRAME ADJUSTER	1
19	SEAT BACK ADJUSTER	1
20	LEG HOLDER	1
21	LEG EXTENSION ARM	1
22R	RIGHT PULLEY HEIGHT ADJUSTER	1
23L	LEFT PULLEY HEIGHT ADJUSTER	1
24	ROTATING PULLEY HOLDER	2
25	DOUBLE PULLEY BLOCK	1
26	SINGLE PULLEY BLOCK	2
27	ADJ. PULLEY BLOCK	1
28	METAL HINGE	2
29	TOP GUIDE ROD HOLDER	1
30	TOP PLATE	1
31	SELECTOR ROD	1

32	WEIGHT PLATE	19
33	STACK SPACER	2
34	LINK PLATE	2
35	LEVER HANDLE	1
36	FOAM ROLLER HOLDER	2
37	PRESS ARM AXLE	1
38	SEAT FRAME AXLE	1
39	BACK PAD	1
40	SEAT PAD	1
41	FOAM PAD	6
42	FOAM PAD COVER	6
43	LONGER PRESS ARM FOAM TUBE	2
44	SHORTER PRESS ARM FOAM TUBE	2
45	LEVER HANDLE FOAM TUBE	1
46	HOOK PLATE	1
47	AXLE COLLAR	2
48	1" ID SEAL RINGLET	2
49	LAT BAR	1
50	CURL BAR	1
51	SPORT BAR	1
52	LONG BAR	1
53	1" X 295L FOAM GRIP	1
54	1" X 900L FOAM GRIP	1
55	SPORT BAR COLLAR	3
56	CHIN ASSIST STRAP	1
57	ANKLE STRAP	1
58	SINGLE HANDLE	2
59	TRICEP ROPE	1
60	CHAIN	2
61	SNAP HOOK	5
62	1" X 200mm ROUND HAND GRIP	2
63	1-1/4" X 125mm ROUND HAND GRIP	2
64	1-1/4" X 130mm HAND GRIP	2
65	32mm ROUND END PLUG	2

66	140mm PULLEY	1
67	90mm PULLEY	33
68	50 X 100mm OVAL END CAP	4
69	50 X 50mm END CAP	1
70	50 X 50mm END PLUG	8
71	25 X 50mm END PLUG	6
72	40 X 80mm OVAL PLUG FOR UPRIGHT FRAME	2
73	25mm ROUND PLUG	2
74	PLASTIC BUSHING	4
75	PLASTIC CAP	6
76	ALUMINUM CAP	6
77	RUBBER CUSHION	4
78	PRESS ARM STOPPER	4
79	STOPPER	1
80	SPACER	1
81	PLASTIC GUIDE ROD HOLDER	2
82	3/4" BUSHING	2
83	5/8" BUSHING	2
84	1/2" BUSHING	4
85	3/8" BUSHING	6
86	12mm 6001ZZ BEARING	6
87	1/2" X 1-1/8 BEARING	2
88	SPRING	2
89	C - RING	3
90	STOPPER	2
91	SPRING KNOB	1
92	KNOB	2
93	SHORTER POP PIN	1
94	LONGER POP PIN	1
95	SELECTOR PIN	2
96	TOP CABLE	1
97	CONNECT CABLE	1
98	LOWER CABLE	1
99	H / L CABLE	2

100	EXTENSION CABLE	1
101	5/8" X 5-1/2" HEX BOLT	1
102	1/2" X 4-1/4" HEX BOLT	2
103	3/8" X 4-1/4" HEX BOLT	4
104	3/8" X 3-1/2" HEX BOLT	2
105	3/8" X 3-1/8" HEX BOLT	6
106	3/8" X 3" HEX BOLT	1
107	3/8" X 2-3/4" HEX BOLT	3
108	3/8" X 2-1/2" HEX BOLT	4
109	3/8" X 1-3/4" HEX BOLT	29
110	3/8" X 1-3/4" HEX THREADED BOLT	2
111	3/8" X 1" HEX THREADED BOLT	4
112	TOP PLATE BOLT	1
113	5/16" X 1-1/4" ROUND HEAD ALLEN BOLT	6
114	3/8" X 3/4" BUTTON HEAD BOLT	2
115	3/8" X 1/2" BUTTON HEAD BOLT	1
116	5/16" X 5/8" BUTTON HEAD BOLT	6
117	5/16" X 1/2" BUTTON HEAD BOLT	6
118	3/8" X 1" SUNKEN HEAD BOLT	4
119	5/16" X 1-1/4" SUNKEN HEAD BOLT	5
120	5/16" X 1/2" INNER HEX SCREW	1
121	5/16" X 1/4" INNER HEX SCREW	5
122	M6 X 1/4" INNER HEX SCREW	2
123	5/16" SMALLER NUT	6
124	5/16" LARGER NUT	4
125	5/8" WASHER	2
126	1/2" WASHER	4
127	3/8" LARGER WASHER	1
128	3/8" SMALLER WASHER	54
129	5/16" LARGER WASHER	6
130	5/16" SMALLER WASHER	10
131	5/16" SPRING WASHER	2
132	5/8" NYLON NUT	1
133	1/2" NYLON NUT	2

134	3/8" NYLON NUT	57
135	1/2" NUT	5
136	3/8" NUT	2
137	4mm HEX WRENCH	1
138	5mm HEX WRENCH	1
139	40 X 80mm OVAL PLUG FOR PRESS ARM	2
140	HDR FOR LONGER POP PIN	1
141	PLASTIC TUBE	2
142	RUBBER COVER	4
143	NON SLIP	2

8.3 Parts List: Leg Press

No.	Name	Qty.
300	PULLEY BRACKET	1
301	BASE FRAME	1
302	CONNECTING REAR STABILIZER	1
303	LEG PRESS SUPPORT	1
304	FOOT PLATE	1
305	CONNECTOR FRAME	1
306	LEG PRESS SUPPORT	1
307	BACK PAD ADJUSTER	1
308R	RIGHT SEAT HANDLE	1
309L	LEFT SEAT HANDLE	1
310	φ3/4" LONG AXLE	2
311	φ25mm AXLE	1
312	COLLAR	2
313	φ3/4" BUSHING	6
314	114mm PULLEY	1
315	90mm PULLEY	5
316	LEG PRESS CABLE	1
317	BACK PAD	1
318	SEAT PAD	1
319	ROUND PLUG	2

320	1-1/4" X 180mm HAND GRIP	2
321	45 X 45mm RECT. PLUG	1
322	50 X 100mm OVAL END CAP	2
323	50 X 100mm OVAL PLUG	1
324	DOME END CAP	8
325	PLASTIC STOPPER	1
326	SEAT PAD SUPPORT STOPPER	2
327	BEARING	2
328	LOCKING SPRING KNOB	1
329	1/2" X 5" HEX BOLT	4
330	1/2" X 3/4" HEX THREADED BOLT	8
331	3/8" X 4-3/4" HEX BOLT	3
332	3/8" X 4-1/2" HEX BOLT	1
333	3/8" X 3-1/4" HEX BOLT	2
334	3/8" X 2-3/4" HEX THREADED BOLT	2
335	3/8" X 1-3/4" HEX BOLT	3
336	3/8" X 1" INNER HEX SCREW	3
337	3/8" X 3/4" SET SCREW	1
338	5/16 X 1-1/4" SET SCREW	2
339	1/2" WASHER	14
340	3/8" WASHER	12
341	1/2" NYLON NUT	2
342	3/8" NYLON NUT	10
343	5/16" NUT	2
344	RUBBER STOPPER	1
345	5mm HEX WRENCH	1
346	φ3/4" SHORT AXLE	1
347	3/8" X 3" HEX BOLT	2

8.4 Parts List: Back Support

No.	Name	Qty.
401	HANDLE BAR	1
402	HANDLE BAR	1
403	FOAM TUBE	2
404	FOAM PAD	1
405	FOAM PAD COVER	1
406	PLASTIC COVER	2
407	SPRING	1
408	1-1/4" ROUND PLUG	1
409	C PIN	2
410	M5 X 35L SCREW	1
411	M5 NUT	2
412	M5 X 30L SCREW	1
413	1" ROUND PLUG	1

8.5 Exploded Drawing: MFT

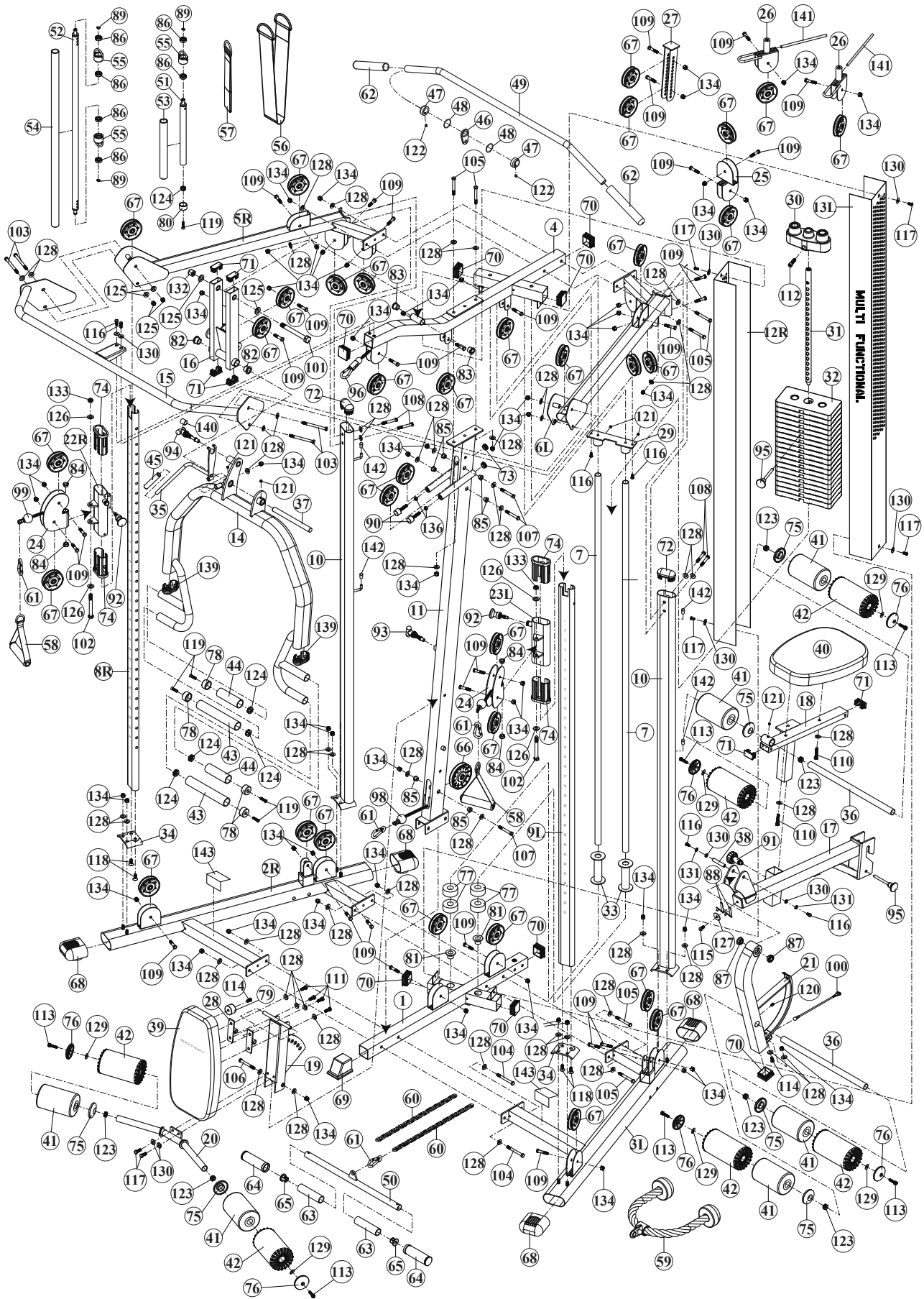

8.6 Exploded Drawing: Leg Press

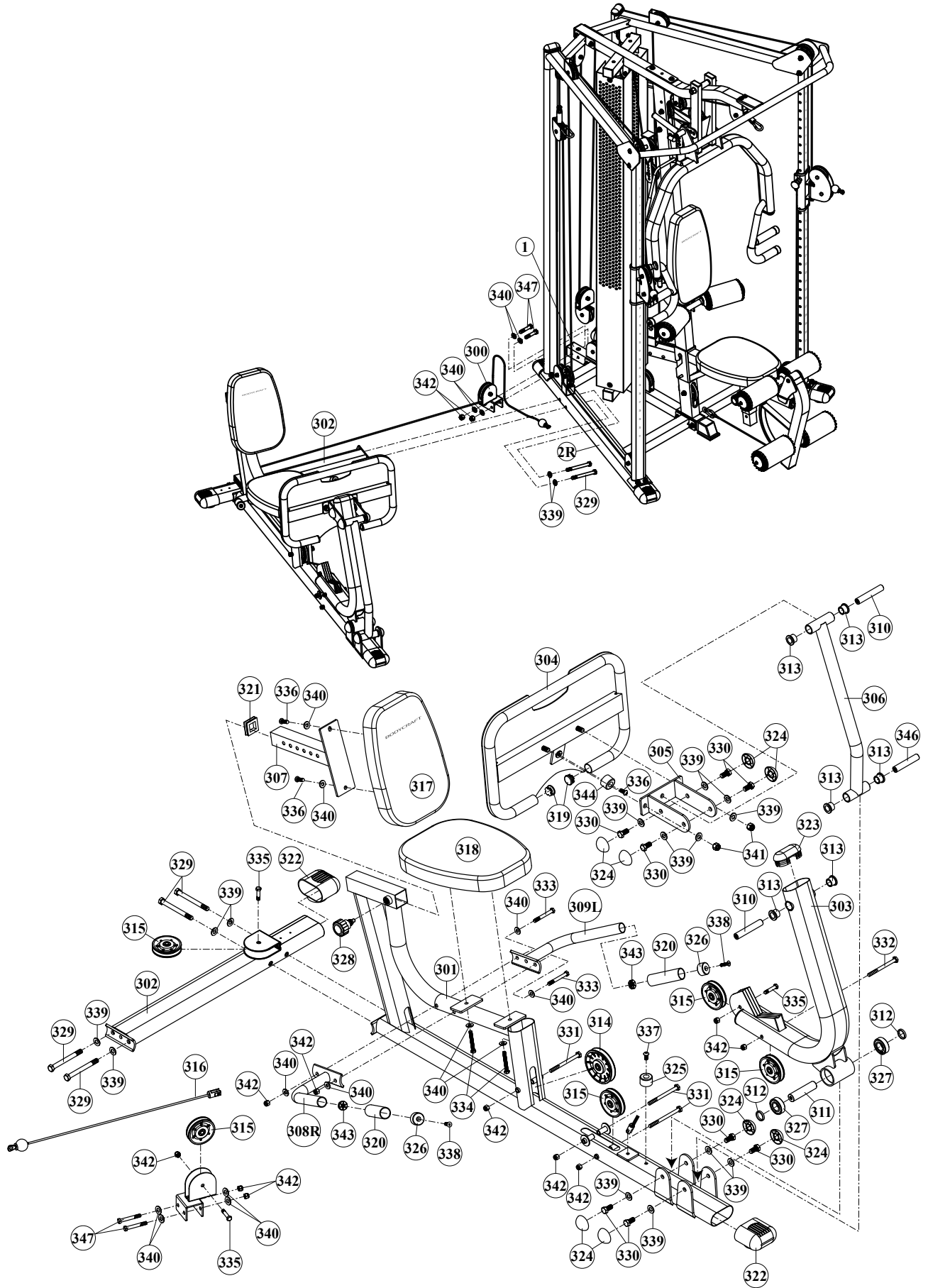

8.7 Exploded Drawing: Back Support

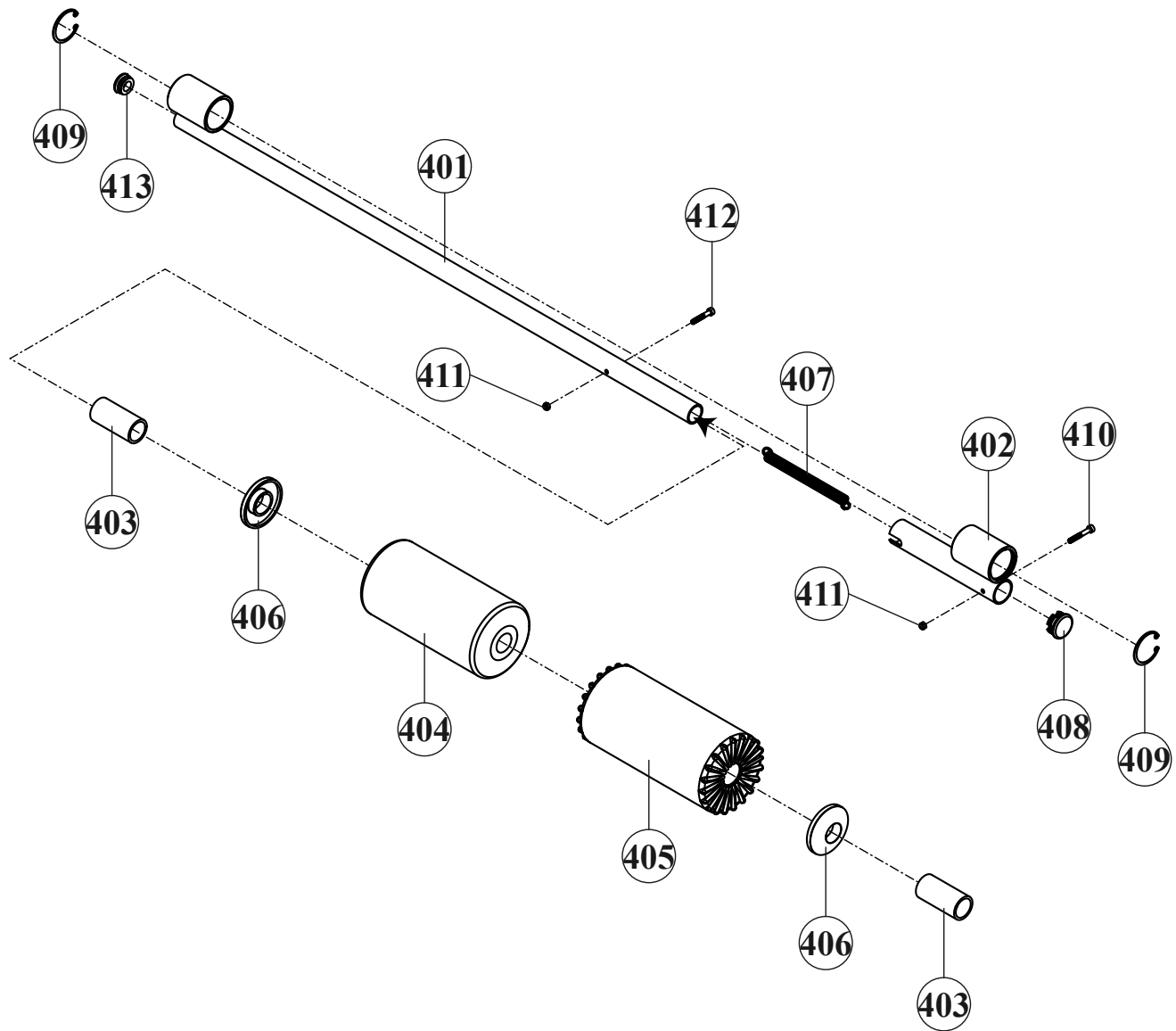

Products from BodyCraft® are subject to strict quality control. However, if a fitness equipment purchased from us does not work perfectly, we take it very seriously and ask you to contact our customer service as indicated. We are happy to help you by phone via our service hotline.

Error Descriptions

Your fitness equipment is developed for long-term, high-quality training. However, should a problem arise, please first read the operating instructions. For further assistance, please contact your contract partner or call our service hotline. To ensure your problem is solved as quickly as possible, please describe the defect as exactly as possible.

In addition to the statutory warranty, we provide a warranty for every fitness equipment purchased from us according to the following provisions.

Your statutory rights are not affected.

Warrantee

The warrantee is the first/original buyer.

Warranty periods

The following warranty periods begin on delivery of the fitness equipment.

Warranty period

The warranty periods, shown on our web shop, begin on delivery of the fitness equipment. The respective warranty periods for your equipment can be found on its product website.

Repair Costs

According to our choice, there will either be a repair, a replacement of individual damaged parts or a complete replacement. Spare parts, that have to be mounted while assembling the equipment, have to be replaced by the warrantee personally and are not a part of repair. After the expiration of the warranty period, the responsibility for parts costs, repair costs, installation costs and delivery costs lies with the warranty holder.

The terms of use are defined as follows:

- + Home use: solely for private use in private households up to 3 hours per day
- + Semi-professional use: up to 6 hours per day (e. g. rehabilitation centres, hotels, clubs, company gyms)
- + Professional use: more than 6 hours per day (e. g. commercial gyms)

Warranty Service

Within the warranty period, equipment which develops faults as a result of material or manufacturing defects, will be repaired or replaced at our discretion. Ownership of equipment or parts of equipment which have been replaced is transferred to us. The warranty period is not extended nor does a new warranty period begin following repair or replacement under the warranty.

Warranty Conditions

For the warranty to be valid, the following steps must be taken:

Please contact our customer service by email or phone. If the product under warranty has to be sent in for repair, the seller bears costs. After expiry of the warranty, the buyer bears the costs of transport and insurance. If the fault is covered by our warranty, you will receive a new or repaired equipment in return.

Warranty claims are invalid in case of damage resulting from:

- + misuse or improper handling
- + environmental influences (moisture, heat, electrical surge, dust, etc.)
- + failure to follow the current safety measures for the equipment
- + failure to follow the operating instructions
- + use of force (e. g. hitting, kicking, falling)
- + interventions which were not carried out by one of our authorized service centres
- + unauthorised repair attempts

Proof of Purchase and Serial Number

Please make sure that you are able to provide the appropriate receipt when claiming on your warranty. So that we can clearly identify the model of your equipment, and for the purposes of our quality control, you will need to give the serial number of your equipment, when contacting the service team. Where possible please have your serial number and your customer number ready when you call our service hotline. It will help us to deal with your request swiftly.

If you cannot find the serial number on your fitness equipment, our service team is at your disposal to offer further information.

Service outside of the Warranty Period

We are also happy to issue an individual cost estimate if there is a problem with your fitness equipment after the warranty has expired, or in cases which do not fall under the terms of the warranty, e. g. normal wear and tear. Please contact our customer service team to find a quick and cost-effective solution to your problem. In such a case you will be responsible for the delivery costs.

Communication

Many problems can be solved just by speaking to us as your specialist supplier. We know how important it is to you as a user of the fitness equipment to have problems solved quickly and simply, so you can enjoy working out with minimal interruption. For that reason, we also want to resolve your queries quickly and in a straightforward manner. Thus, please always keep your customer number and the serial number of the faulty equipment handy.

10 CONTACT

DE	DK	UK
<p>TECHNIK</p> <p>☎ +49 4621 4210-900 ☎ +49 4621 4210-698 ✉ technik@fitshop.de 🕒 Öffnungszeiten entnehmen Sie unserer Homepage.</p> <p>SERVICE</p> <p>☎ 0800 20 20277 (kostenlos) ☎ 04621 4210 - 0 ✉ info@fitshop.de 🕒 Öffnungszeiten entnehmen Sie unserer Homepage: https://stg.fit/statita</p>	<p>TEKNIK OG SERVICE</p> <p>☎ 80 90 16 50 +49 4621 4210-945 ✉ info@fitshop.dk 🕒 Åbningstider kan findes på hjemmesiden: https://stg.fit/statit7</p>	<p>CUSTOMER CARE</p> <p>☎ +44 141 737 2249 or +44 141 876 3972 ✉ customercare@fitshop.co.uk 🕒 You can find the opening hours on our homepage: https://stg.fit/statitd</p>
	FR	BE
	<p>TECHNIQUE & SERVICE</p> <p>☎ +33 (0) 189 530984 +49 4621 42 10 933 ✉ info@fitshop.fr 🕒 Vous trouverez les heures d'ouverture sur notre site Internet: https://stg.fit/statit4</p>	<p>TECHNIQUE & SERVICE</p> <p>☎ 02 732 46 77 +49 4621 4210 933 ✉ info@fitshop.be 🕒 Vous trouverez les heures d'ouverture sur notre site Internet: https://stg.fit/statit8</p>
ES	NL	INT
<p>TECNOLOGÍA Y SERVICIOS</p> <p>☎ 911 238 029 ✉ info@fitshop.es 🕒 Consulta nuestro horario de apertura en la página web: https://stg.fit/statit5</p>	<p>TECHNISCHE DIENST & SERVICE</p> <p>☎ +31 172 619961 ✉ service@fitshop.nl 🕒 De openingstijden vindt u op onze homepage: https://stg.fit/statit3</p>	<p>TECHNICAL SUPPORT & SERVICE</p> <p>☎ +49 4621 4210-944 ✉ service-int@fitshop.de 🕒 You can find the opening hours on our homepage: https://stg.fit/statita</p>
PL	AT	CH
<p>DZIAŁ TECHNICZNY I SERWIS</p> <p>☎ 22 307 43 21 +49 4621 42 10-948 ✉ info@fitshop.pl 🕒 Godziny otwarcia można znaleźć na stronie głównej: https://stg.fit/statit6</p>	<p>TECHNIK & SERVICE</p> <p>☎ 0800 20 20277 (Freecall) +49 4621 42 10-0 ✉ info@fitshop.at 🕒 Öffnungszeiten entnehmen Sie unserer Homepage: https://stg.fit/statitb</p>	<p>TECHNIK & SERVICE</p> <p>☎ 0800 202 027 +49 4621 42 10-0 ✉ info@fitshop.ch 🕒 Öffnungszeiten entnehmen Sie unserer Homepage: https://stg.fit/statit9</p>

Please find a detailed overview including address and opening hours for all stores of Fitshop UK on the following website:

www.fitshop.co.uk/storelocator

WE LIVE FITNESS

WEBSHOP AND SOCIAL MEDIA

The Fitshop Group is Europe's largest specialist for home fitness equipment with currently 70 stores and one of the world's most renowned online mail order companies for fitness equipment.

Fitshop UK is part of the Fitshop Group. Private customers order via the 25 web shops in the respective national language or have their desired equipment assembled on site. In addition, the company supplies fitness studios, hotels, sports clubs, companies and physio practices with professional equipment for endurance and strength training.

The Fitshop group offers a wide range of fitness equipment from renowned manufacturers, high-quality in-house developments and comprehensive services, such as a build-up service and sports scientific advice before and after the purchase. The company employs numerous sports scientists, fitness trainers and competitive athletes.

Visit us also on our social media platforms or our blog!



<https://www.fitshop.co.uk>
www.fitshop.co.uk/blog



www.facebook.com/fitshop.co.uk



www.instagram.com/fitshop_uk



www.youtube.com/@fitshop_uk

TAURUS

cardiostrong

BODYCRAFT

BodyMax

Notes

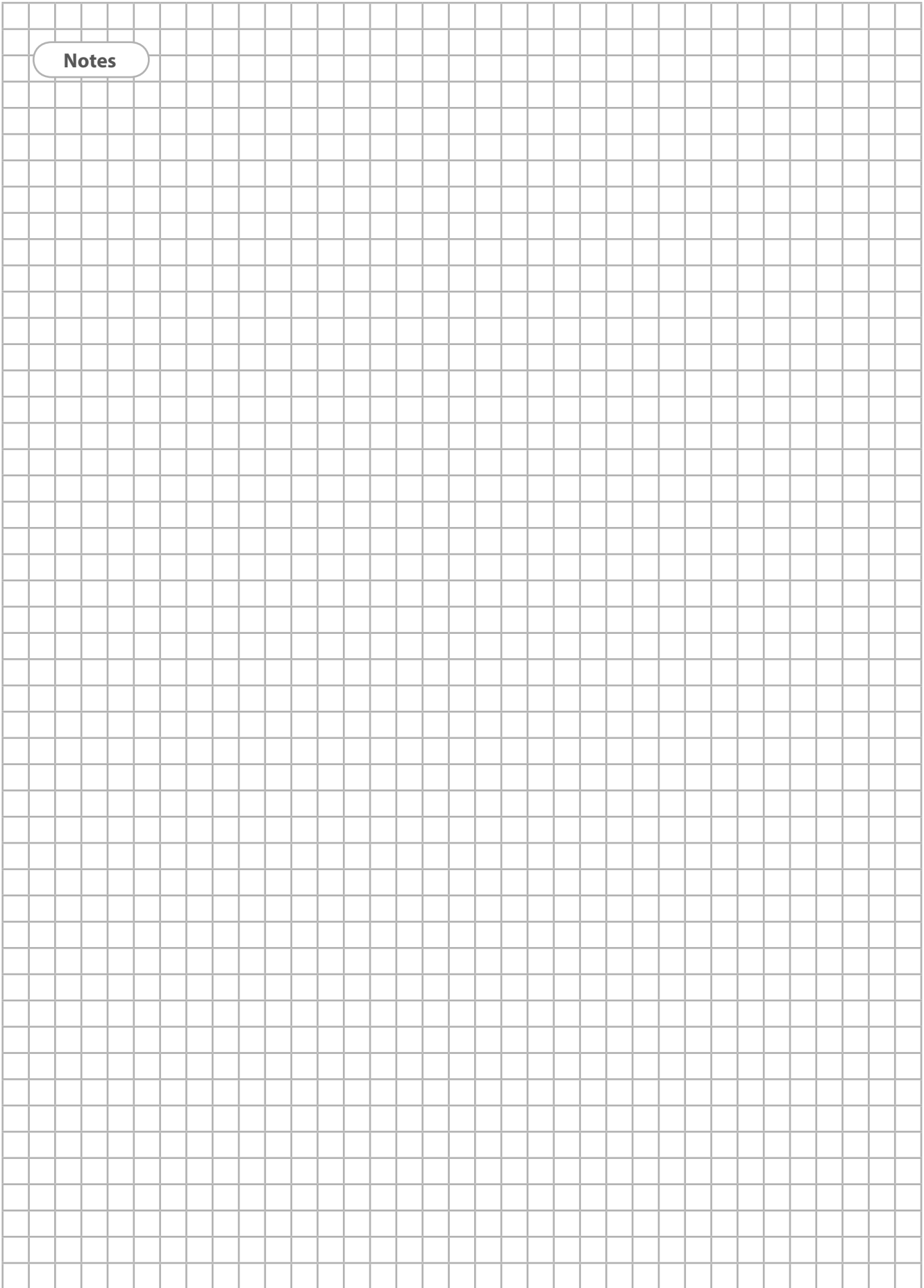

BODYCRAFT