

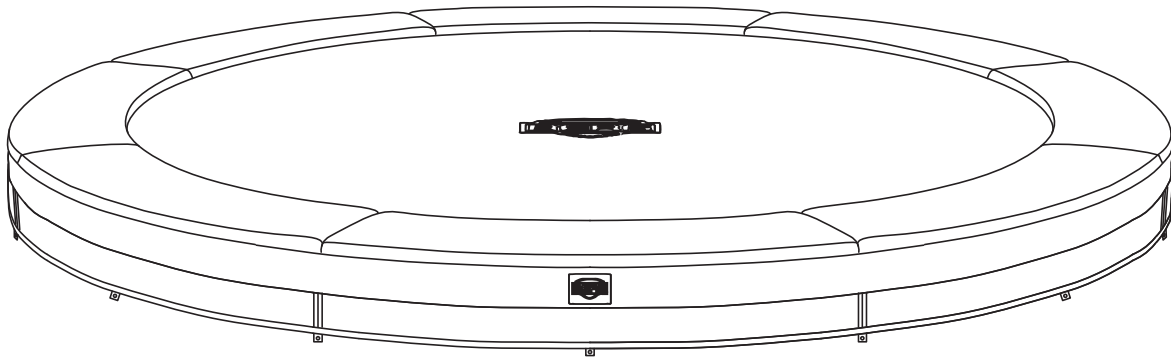

BERG InGround Favorit

User manual
Gebruikshandleiding
Gebrauchsanweisung
Mode d'emploi
Instruktionsbok
Brugermanual

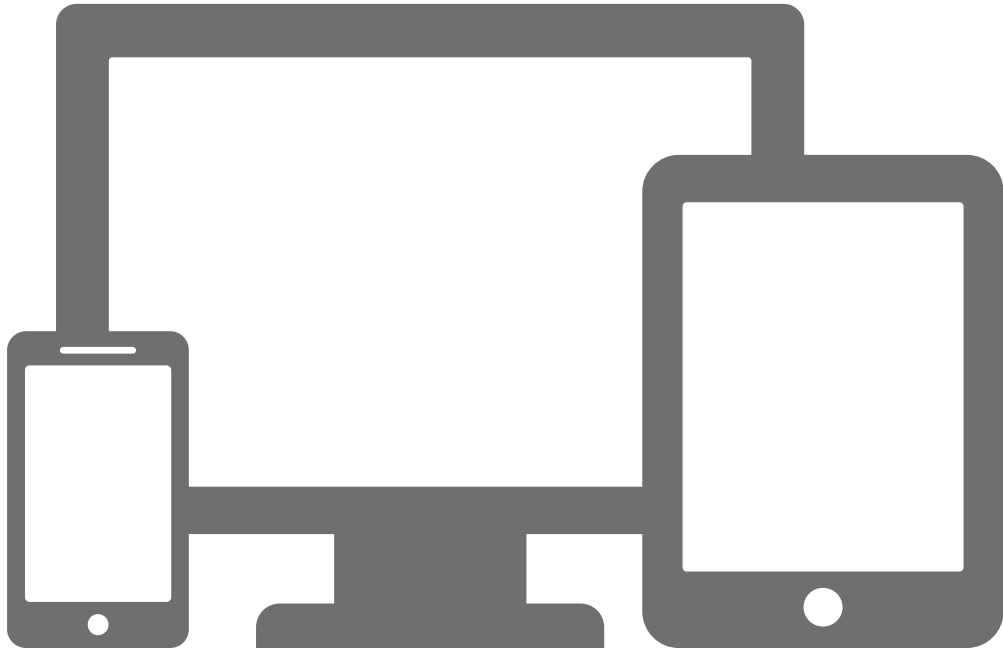



Go to the BERG toys channel on



for installation instruction video's
www.youtube.com/bergtoys

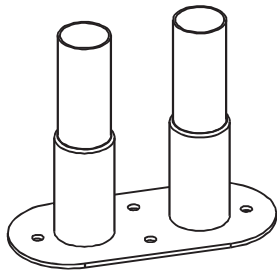

1

8x

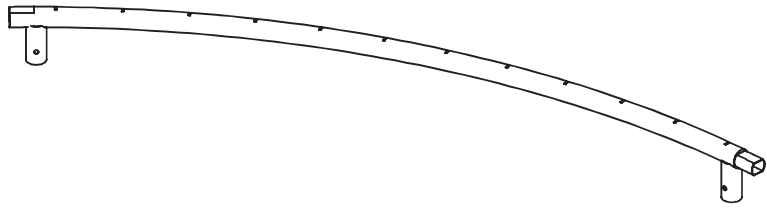

2

8x

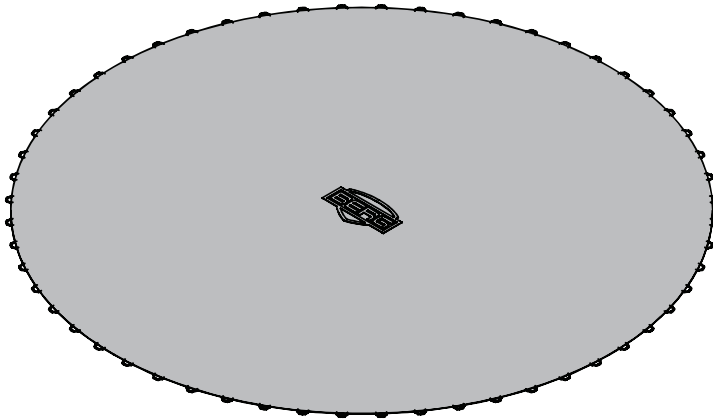

3

1x

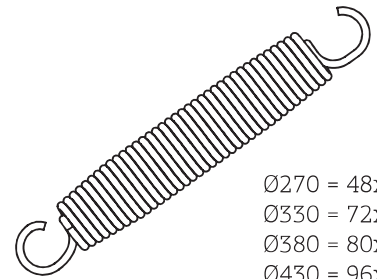

Ø270 = 48x
Ø330 = 72x
Ø380 = 80x
Ø430 = 96x

4

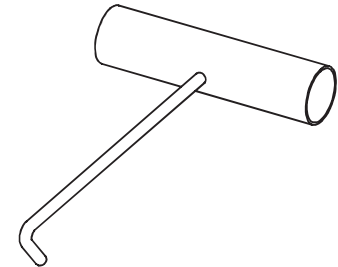

5

1x

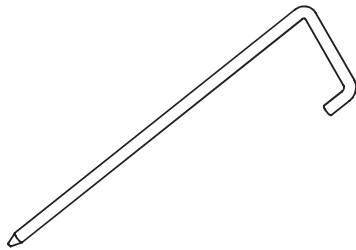

6

32x

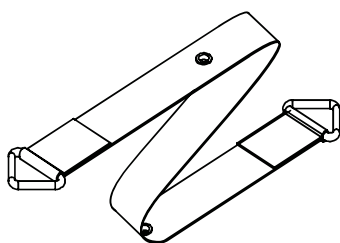

7

1x

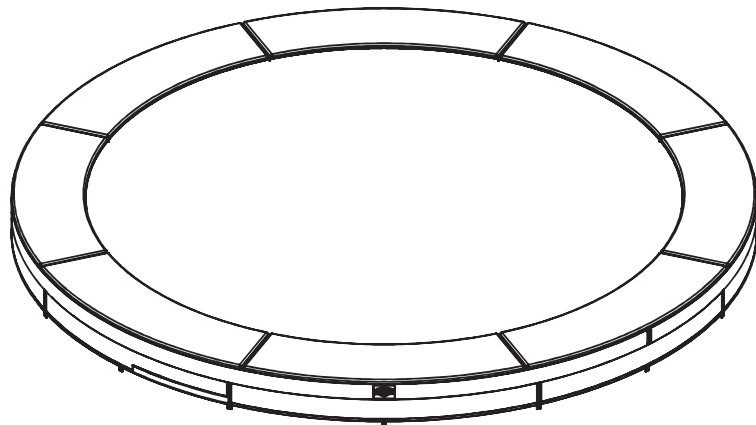

8

1x



BERG InGround Favorit

1

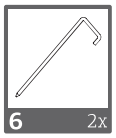
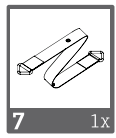
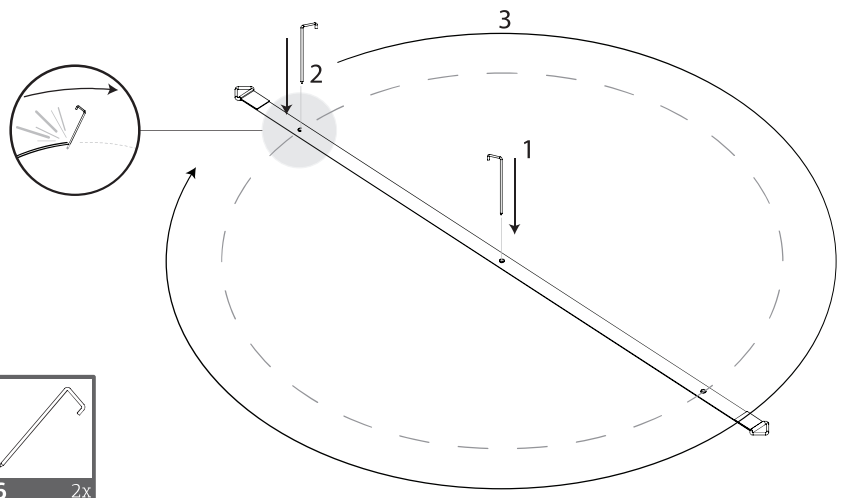

2

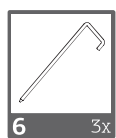
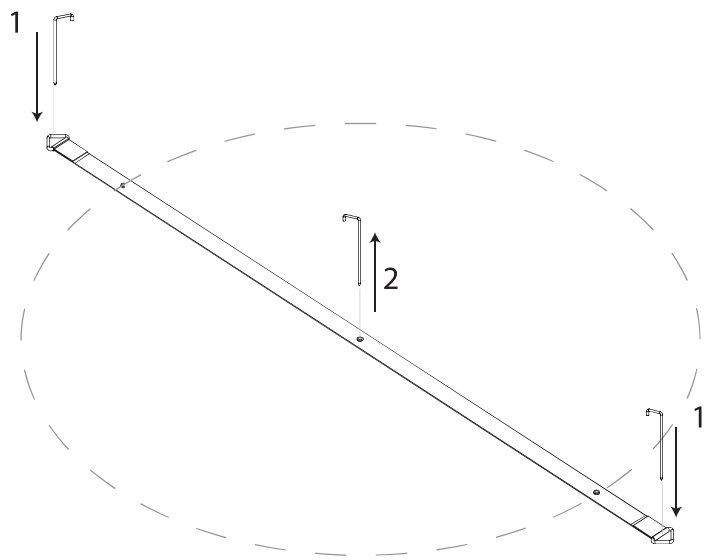

3

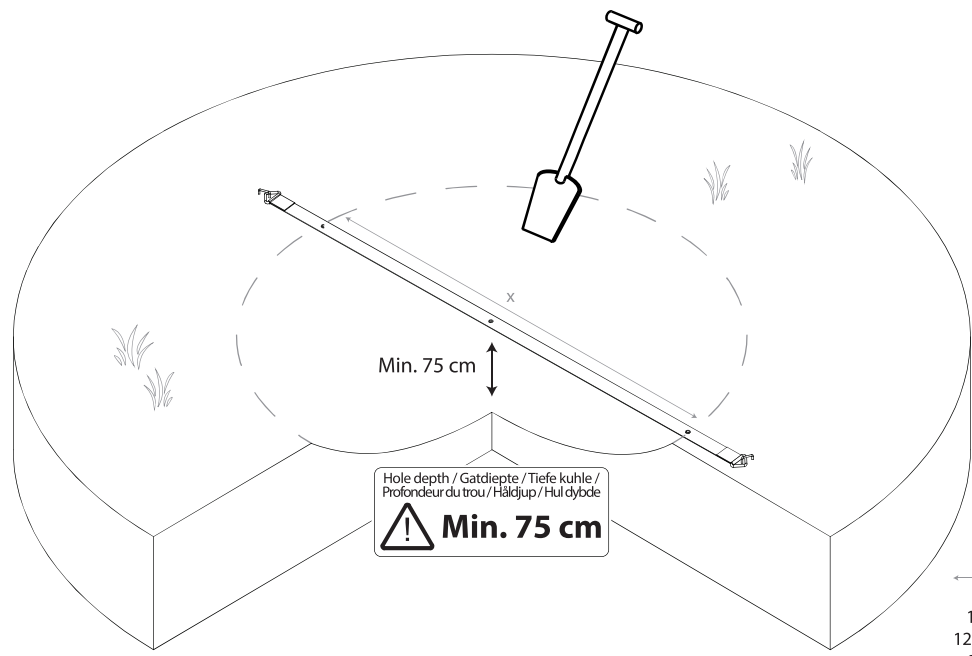

Hole depth / Gatdiepte / Tiefe kuhle /
 Profondeur du trou / Håldjup / Hul dybde
Min. 75 cm

x
 9ft / 270 : 230 cm
 11ft / 330 : 290 cm
 12,5ft / 380 : 340 cm
 14ft / 430 : 390 cm



4

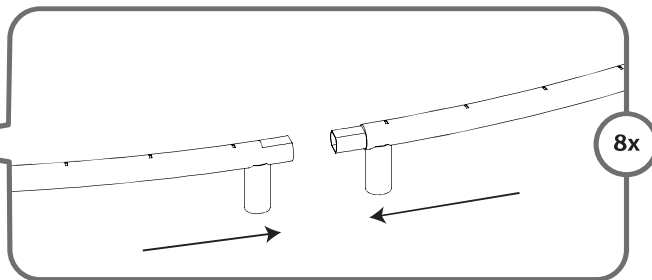
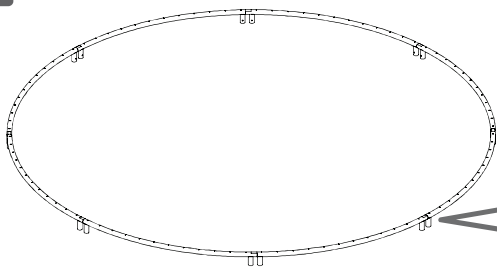

8x

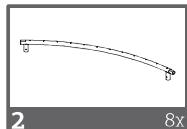

2

8x

5

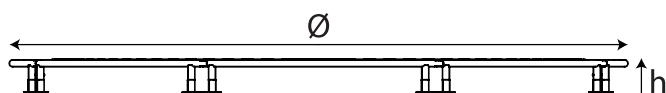

	Ø	h
270 (9ft)	2,7 m	0,2 m
330 (11ft)	3,3 m	0,2 m
380 (12,5ft)	3,8 m	0,2 m
430 (14ft)	4,3 m	0,2 m

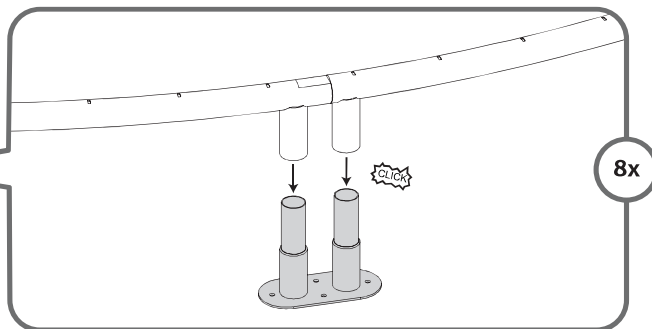
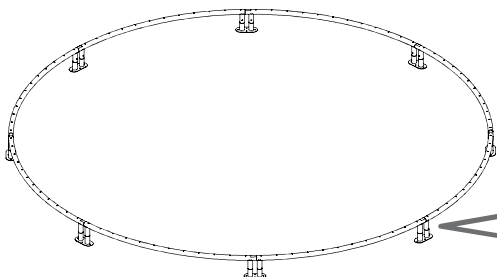

8x

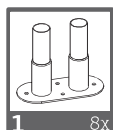

1

8x

6

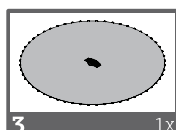
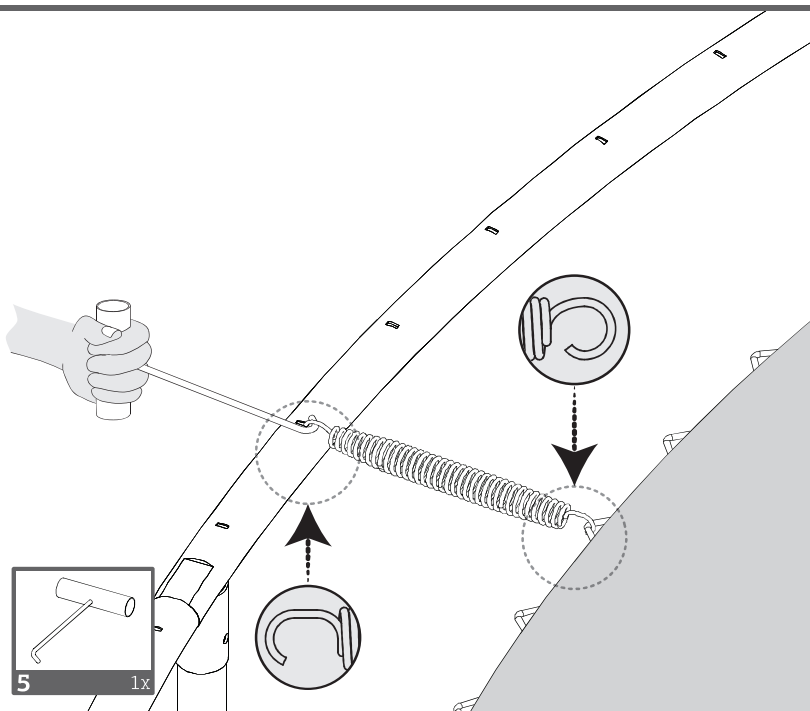

3

1x

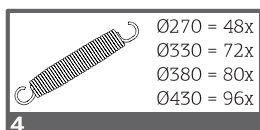

4

Ø270 = 48x
 Ø330 = 72x
 Ø380 = 80x
 Ø430 = 96x

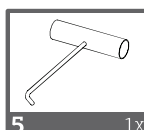

5

1x



7

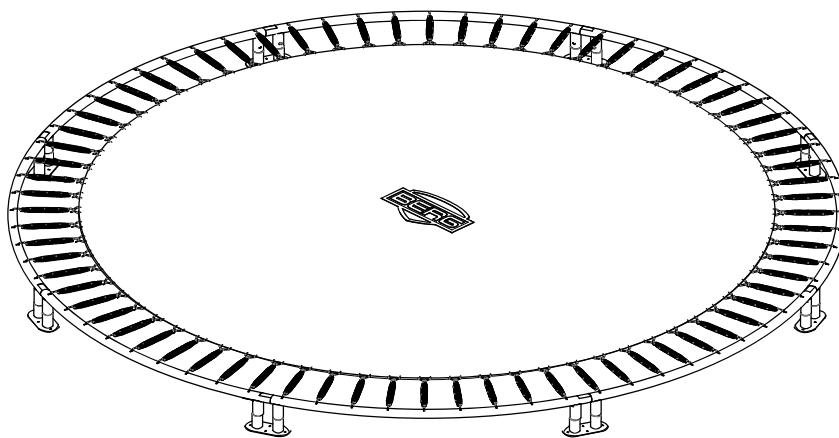
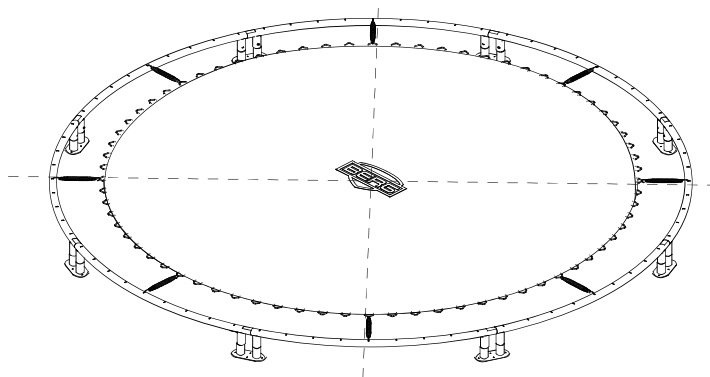
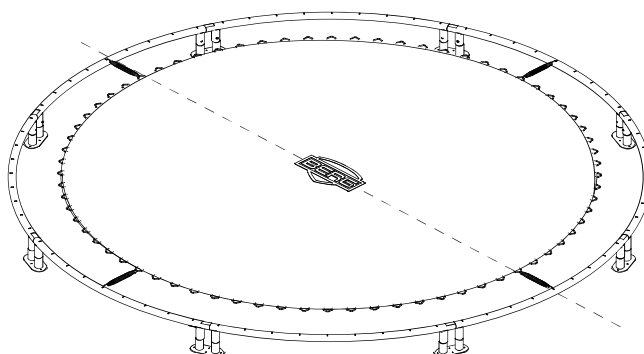
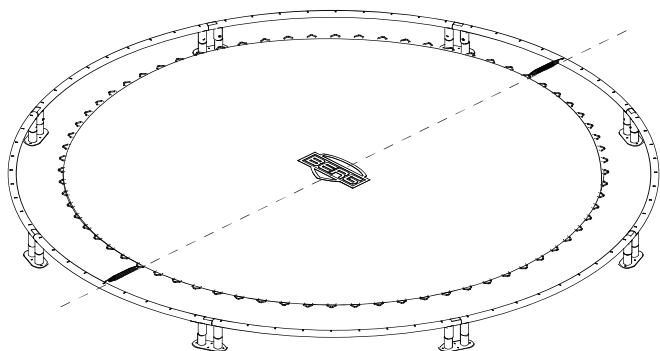



8

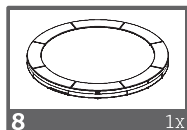
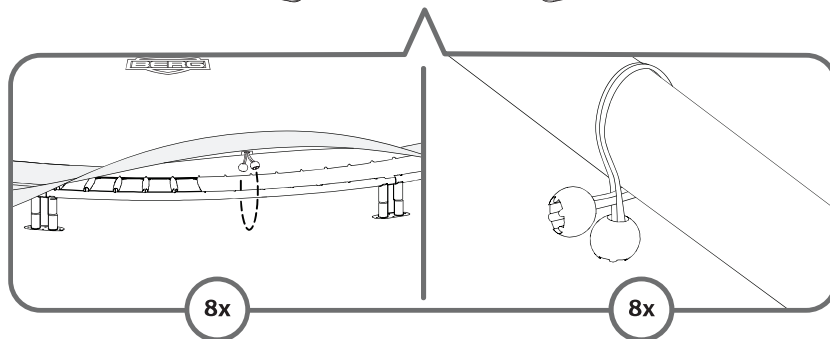
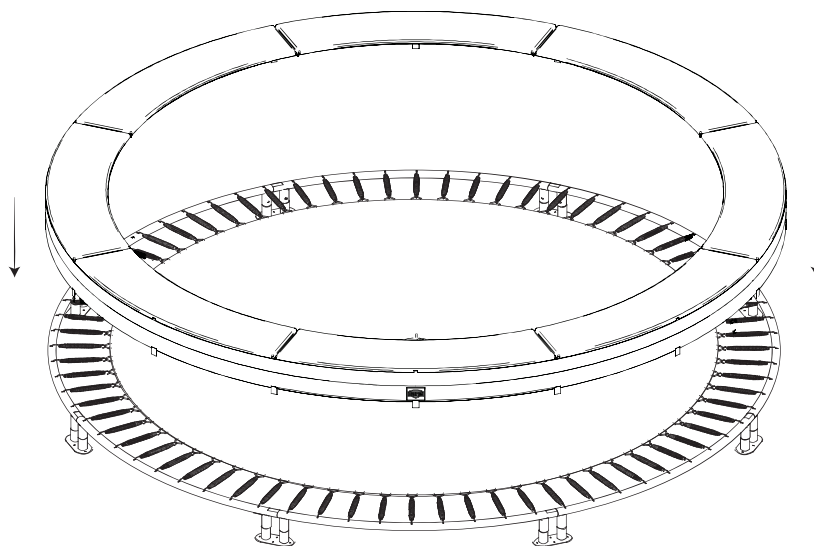

9

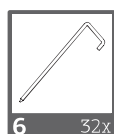
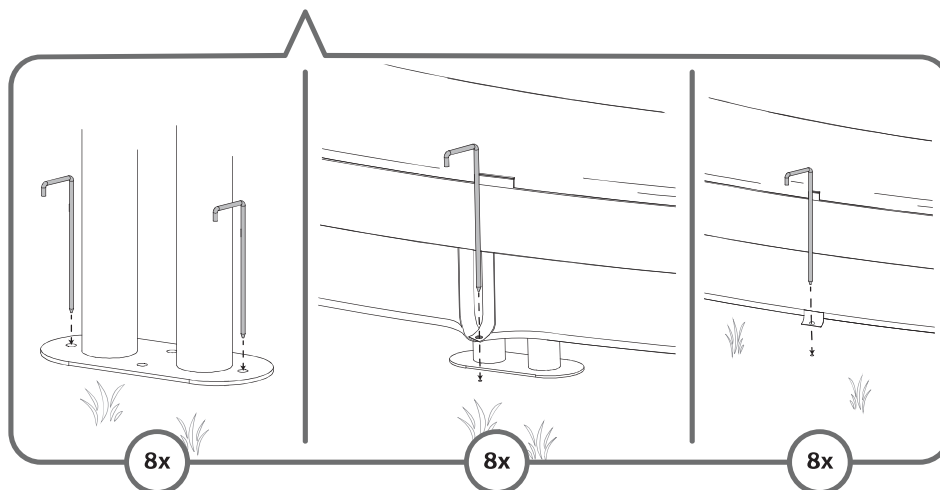
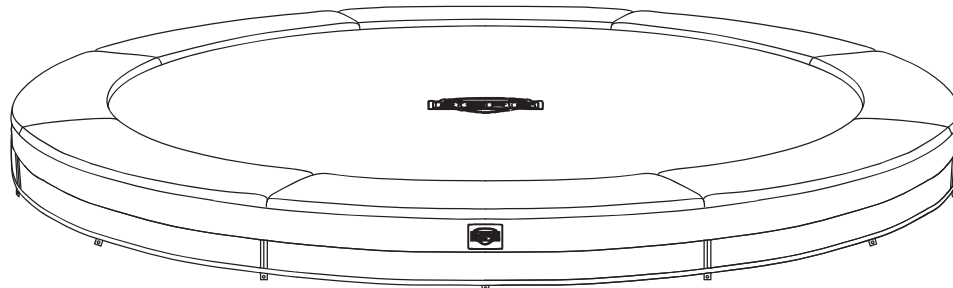



Index

1. Introduction
2. Warnings
 - 2.1 General warnings
 - 2.2 Safety net warnings
3. Information
4. Product description
5. Jumping instructions
 - 5.1 Before you start jumping
 - 5.2 Jumping instructions
 - 5.3 Basic jumps
6. Assembly and maintenance instructions
 - 6.1 Assembly
 - 6.2 Maintenance instructions
 - 6.3 Disassembly and storage
 - 6.4 Repairs
7. Warranty
 - 7.1 Warranty period
 - 7.2 Warranty conditions

1. Introduction

Trampoline usage encourages active and healthy play. It has a positive impact on stress, physical condition and blood circulation. Trampoline jumping is for the young and young at heart!

Thank you for choosing BERG as your trampoline purchase of choice. We are confident you will get many years of beneficial use and jumping pleasure.

This manual provides tips about assembly, safe use and jumping instructions for many years of trouble-free use. Jumping on a trampoline is not dangerous as long as you follow the safety instructions.

Read the instructions carefully and store for future reference.

BERG wishes you a fun and active jumping experience!



2. Warnings

2.1 General warnings

- The weight of the user may not exceed:

270 (9ft)	330 (11ft)	380 (12,5ft)	430 (14ft)
70kg	100kg	110kg	120kg

- The BERG trampoline is not recommended for use by children under 6 years of age.
- Not suitable for children under 36 months. Fall hazard.
- Not suitable for children under 36 months. Choking hazard, small parts.
- Adult assembly required.
- The BERG trampoline is for outdoor use only.
- Read instructions thoroughly and store for future reference.
- The trampoline should be assembled in accordance to the assembly instructions. BERG recommends reviewing final assembly prior to usage.
- Only one user. Collision hazard. Use by multiple persons can cause serious injury.
- Jump without shoes.
- Do not use the mat when it is wet.
- Empty pockets and hands before jumping.
- Always jump in the middle of the mat.
- Do not eat while jumping.
- Do not exit by a jump.
- Limit the time of continuous usage (make regular stops).
- Do not use in strong wind conditions and secure the trampoline.
- No somersaults. Landing on the head or neck can cause serious injury, even when landing in the middle of the bed.
- Adult supervision required.
- Usage of BERG trampoline while under the influence of alcohol or drugs is prohibited.
- Objects, animals or persons are prohibited underneath the BERG trampoline.

2.2 Safety net warnings

- Ensure entrance of safety net is completely closed prior to BERG trampoline usage.
- Jumping over the safety net is prohibited.
- Crawling between trampoline padding and underside of safety net is prohibited.
- Usage of compatible safety net is recommended to ensure safe jumping.
- Jumping intentionally into the safety net is prohibited.
- Climbing into or hanging from the safety net is prohibited.
- Ensure clothing of user does not contain any hooks, loops, drawstrings or other loose parts that could potentially latch on to the safety net.
- Attaching non-BERG compliant accessory or sparepart to the BERG safety net is prohibited.
- Climbing on the poles of the safety net is prohibited.
- Safety net entrance is the only entrance or exit point of the BERG trampoline.
- Keep fire away from the safety net.
- The net should be replaced every 5 years (or earlier when loss of functionality).



3. Information

- BERG product to be used as defined in manual. Usage that deviates from manual instruction may potentially lead to serious injury or damage of product. Read all instructions prior to trampoline usage. To ensure safe and enjoyable usage of the BERG trampoline, warnings, instructions for care and maintenance are included.
- Should the trampoline require movement to another current location (short distance), disassemble the anchors (if any) first prior to relocation. It is recommended the trampoline be lifted via the top rails by 3 adults. Should the trampoline require relocation over a greater distance, it is recommended to disassemble the trampoline parts, re-pack in the original packaging and assemble again at the new location.
- Ensure that the BERG trampoline is level after installation.
- Ensure a minimum clearance of at least 2 meters from trees, fences and any other surrounding obstacles.
- It is required to have a minimum overhead clearance of 7 meters measured from the surface on which the trampoline is standing.
- Installing the BERG trampoline on concrete, asphalt or any other hard surface or in proximity of other playground installations (pools, swings, slide sets or any other play structures) is prohibited.
- For safety reasons, unless BERG-approved, modifications or changes to the trampoline is prohibited. Repairs must be carried out by a professional. Please consult your BERG dealer.

4. Product description

- The frame of the BERG trampoline is galvanized for corrosion protection. Maintaining your BERG trampoline in accordance to recommended tips and care will help elongate trampoline life.
- To ensure many years of enjoyment, The BERG trampoline is manufactured using high-quality materials-only. Proper maintenance and care promotes a long lifespan and injury prevention.

5. Jumping instructions

5.1 Before you start jumping

- Objects, animals or persons are prohibited underneath the BERG trampoline.
- Only use the BERG trampoline when it is clean and dry.
- Objects and other obstacles that can interfere with jumping should be prohibited from the jumping area.

5.2 Jumping instructions

- Proper movement while using the BERG trampoline requires good posture. Correct posture and balance are achieved by tensing the muscles.
- Good posture ensures safe usage of the BERG trampoline. When jumping, the body is exposed to shocks that require correct absorption. By tensing your muscles, you obtain better control over your balance and this results in more the jumping resilience. In contrast, a more relaxed posture leads to loss of energy and jumping resilience. Begin with the basic jumps and jumping positions and only increase complexity when mastered. To come to a stop position when jumping, bend knees when your feet touch the mat.
- Always jump in the middle of the mat. Avoid jumping on mat edge and trampoline padding.
- To come to a stop position when jumping, bend and flex knees when your feet touch the mat. Learn this skill before attempting others.
- Learn fundamental bounces and body positions thoroughly before trying more advanced skills. A variety of jumping techniques can be carried out solo or in series and/or combinations between bounces.
- Avoid bouncing too high. First obtain jumping control with proper landing position in middle of mat. From a safety perspective, control is more important than height.
- To ensure and maintain control while jumping, ensure jumping posture is straight, head is in upright position and eyes are focused on the jump mat.

- Movements that cause considerable friction (such as a “sliding” action) on the printing on the jumping mat or the padding are not recommended. Heavy friction when sliding over the printing on the jumping mat or the padding could result in the ink rubbing off onto skin or clothing. It may be difficult to remove the ink from clothing. The ink meets the stringent chemical requirements imposed on toy products, therefore contact with the skin or ingestion of this ink has no harmful effects on human health.

5.3 Some basic jumps

Basic bounce

Upright position, head held in upright position. Eyes focused on the jump mat. While jumping upwards, swing arms forward and in circular motion and point your toes downwards. Keep feet positioned together, toes pointed downwards when returning back to the jump mat. When landing on the jump mat, keep your feet approximately 40cm apart.

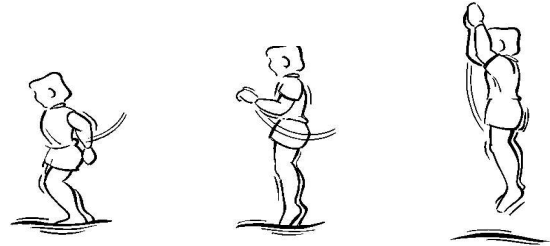

Hands and knees bounce

Commence with basic bounce. Keep eyes focused on jump mat. Swing arms forward and in circular motion. Land on hands and knees. Push off with hands and return to upright position.

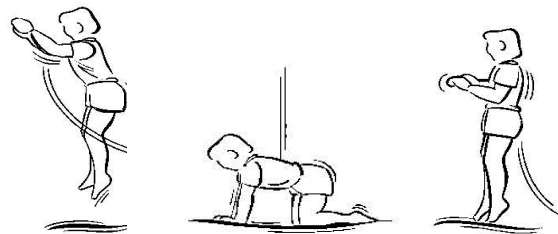

Seat drop

Commence with basic bounce. Keep eyes focused on jump mat. Land in sitting position. Place hands next to hips on jump mat when in sitting position. Push off with hands en return to upright position.

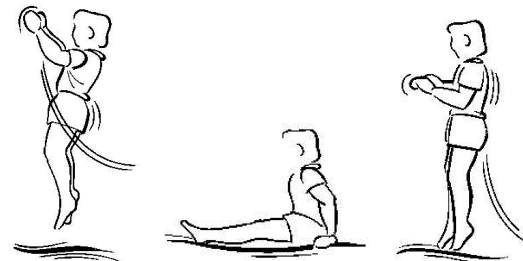

Front bounce

Commence with basic bounce and land on your stomach. Keep head straight. Keep arms extended forward on the jump mat. Push off with hands and return to upright position.

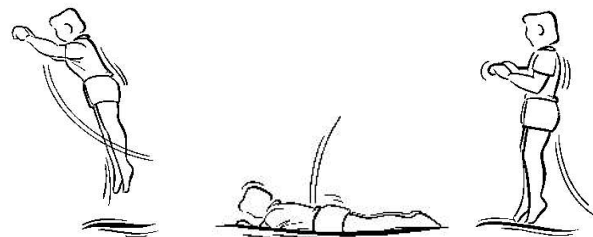

Back drop

Commence with basic bounce and land on your back. Keep chin pressed against your chest during landing. Kick forward and up with legs when returning to a standing position.

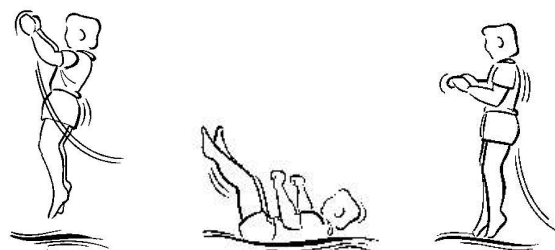



6. Assembly and maintenance instructions

6.1 Assembly

- Do not install the trampoline in extreme windy conditions. Wait until wind subsides.
- Gloves are recommended to be worn while installing the BERG trampoline.
- Ensure the BERG trampoline is level after installation. A bubble level is recommended to help qualify.
- The trampoline should be assembled by an adult in accordance to the assembly instructions. BERG recommends reviewing final assembly prior to usage.
- Assembling of the trampoline comprises of fasteners and fittings with self-locking nuts. These self-locking nuts are for single use only. When disassembling and reassembling, the self-locking nuts must be replaced.
- Location: Find a suitable place for the installation of the trampoline ensuring there are no surrounding obstacles. Verify soil condition and characteristics of designated location to determine installation suitability.
- While digging the hole, soil should be firm to avoid collapsing due to erosion. If necessary, strengthen the sides of the hole or make them smooth to prevent this.
- Should the soil hinder digging a hole, best to choose another location or consult a professional excavation company to provide consultation.
- The dug hole should not contain water.
- Verify if a high ground-water level does not contribute to a collection of water in the hole. In addition, verify there is adequate drainage to dispose rain water.
- As per the diagram in the installation manual, use the included tape measure (located in the packaging) to measure and determine the correct diameter, depth and shape of the dug hole.
- Ensure the hole will be dug according to specifications and that the walls are shaped not too steep.
- Deviation from hole specifications can result in unwanted wall collapse and trampoline instability. Follow the diagrams as presented in the installation manual, step by step.
- The legs of the trampoline support the trampoline frame. Ensure the position of the legs are equal in height and rest firmly on the ground. Anchor the legs with the supplied stakes.
- For installation instructions, refer to page 4.
- For additional trampoline information, contact the manufacturer.
- Install accessories according to the installation manual /guide.

6.2 Maintenance instructions

As described in the assembly manual, inspect the BERG trampoline before each usage and replace broken, worn or missing parts. Ignoring inspections and neglecting maintenance can lead to dangerous situations and unnecessary risks for the user.

Inspect the hole underneath the trampoline periodically. (Minimum once per year) and if required, take corrective measures. As specified in the installation manual, inspect the hole for:

- Proper depth.
- Proper shape.
- Frame stability and uniformity.
- Unwanted objects.

After a rainy period and prior to usage, inspect the trampoline hole. Ensure there is adequate drainage to dispose of rain water.

Should the trampoline require movement to another current location (short distance), disassemble the anchors (if any) first prior to relocation. It is recommended the trampoline be lifted via the top rails by 3 adults. Should the trampoline require relocation over a greater distance, it is recommended to disassemble the trampoline parts, re-pack in the original packaging and assemble again at the new location.



Pay attention to the following:

- The condition of frame joints. (Eg. Broken welds or bent frame).
- The condition of the springs (damaged or excessive stretching) and attachment of the springs to the frame and jumping mat. Springs and suspension springs are subject to wear and tear. Replace worn parts when required.
- Check bolt connections to ensure tightness, tightening when when required. Check the (push pins) connectors to ensure they will not become dislodged while jumping.
- The condition of the jump mat (damage, incorrect tension or sagging of the mat) The jump mat wears with use and exposure to sunlight (UV radiation). Replace the jump mat in a timely manner when the condition worsened.
- Missing, improperly positioned, or insecurely attached protective padding.
- Incorrect stitching, ruffling, tears or holes in jump mat or protective padding.
- Deterioration in the stitching or fabric of the mat or protective padding.
- Check for sharp edges and frame protrusions.
- Strong winds and gusts can result in displacement of the trampoline. BERG recommends securing the trampoline by use of anchors or sandbags and removal of the safety net and jump mat.
- In certain countries during the winter period, snow loads and low temperatures can damage the trampoline. BERG recommends storing the jump mat and safety net indoors during these climate conditions.
- The use of fertilisers (artificial fertiliser, fertiliser pellets, etc.) within a radius of 2 metres around the BERG trampoline is prohibited. Using such products can cause components to rust.
- The jump mat and padding can be cleaned with a cloth and cold water. NEVER use solvents, dishwashing liquid, detergent or hot water.

6.3 Disassembly and storage

- If the trampoline is not used for short periods of time and to avoid jump mat debris caused by fallen leaves and twigs, BERG recommends usage of a BERG Weather Cover. When the trampoline is not used for a longer period of time (e.g. during the winter) BERG recommends storing the trampoline, especially the protective padding, in a dry area to support product longevity.
- Assembling of the trampoline contains fasteners and fittings with self-locking nuts. These self-locking nuts are for single use only. When disassembling and reassembling, the self-locking nuts must be replaced.

6.4 Repairs

Contact our BERG authorized dealers for ordering original parts for the BERG trampoline.



7. Warranty

7.1 Warranty period

- BERG trampolines are of excellent quality. To provide you with years of carefree fun on our trampolines, BERG offers you a functionality warranty. A functionality warranty is a warranty regarding its functional use. Please consult the table below for the term of this warranty (years).

Frame	5
Frame (<i>after product registration</i>)	8 (5+3)
Padding	2
Jump mat	2
Springs	2
Safety Net	2

- With exception to the 1 year warranty of the BERG weather cover basic, the BERG safety nets and accessories are subject to a warranty period of 2 years. Parts that are susceptible to wear and tear (eg. elastics), the influences of weather (eg. rust and discolouration) and the foam on the BERG safety net tubes are excluded from warranty.

7.2 Warranty conditions

The owner of the product can only claim warranty by presenting the original receipt of purchase. The warranty applies only to material and manufacturing defects related to the BERG product and related parts.

The warranty becomes nul and void if:

- The product is used improperly and / or negligently.
- The product is not assembled and maintained in accordance with the instruction manual.
- Technical repairs made to the product are not carried out in a professional manner.
- Replacement parts do not correspond to the technical specifications of the product in question or are installed incorrectly.
- Damage caused by the influences of weather such as rust, UV rays or normal wear and tear.
- Improper burial of the BERG Trampoline.
- The product is used for rental purposes or made available for usage by a 3rd party.
- During the warranty period, all material and construction assessed faults will be repaired or replaced by BERG. Repairs handled at no cost is applicable provided the product is still within its warranty period as stated in article 7.1.
- BERG warranty can only be honored if inspected by a BERG authorized dealer.
- BERG warranty can only be honored if the original proof of purchase is rendered to the BERG authorized dealer. Should the owner have re-located or the BERG dealer is no longer operational, BERG can recommend an alternative BERG dealership.
- If the warranty claim is not honored, all costs incurred must be paid by the owner.
- This warranty is not transferable to third parties.



Product registration

Would you like free supplementary guarantee?*

Don't forget to register your product online immediately!

Go to **www.bergtoys.com/registration**.

This product registration entitles you to 3 years extended warranty on the frame of your go-kart or trampoline.

This extended warranty is in addition to the standard warranty on the frame that you receive.

*For the conditions, please visit www.bergtoys.com/registration



www.bergtoys.com/registration